

Active EMI Input Module for 48 Vdc Bus

Product Description

The QPI-21 active EMI filter attenuates conducted common-mode (CM) and differential-mode (DM) noise over the CISPR22 frequency range of 150 kHz to 30 MHz. The product is designed for use in 48 Vdc bus (36 – 76 Vdc) systems, with 100 Vdc surge capability. The QPI-21's 14 A rating supports multiple DC-DC converter loads up to an ambient temperature of 65°C without de-rating. Designed for the telecom and ITE bus range, the QPI-21 supports the PICMG® 3.0 specification for filtering system boards to the EN55022 Class B limits.

In comparison to passive solutions, the use of active filtering reduces component size and therefore reduces the overall package size. The Picor QPI-21 smaller size saves valuable board real estate and the reduced height enhances airflow.

The QPI-21 is available as a lidded or an open-frame SiP (System-in-Package) module with LGA mounting. Evaluation boards are available to allow for quick in-circuit testing of the QPI-21LZ within an existing system design.

Features

- 45 dB CM attenuation at 250 KHz (50 Ω)
- 80 dB DM attenuation at 250 KHz (50 Ω)
- 80 Vdc (max input)
- 100 Vdc surge 100 ms
- 1,500 Vdc hipot hold off to shield plane
- 14 A rating
- 25.3 x 25.3 x 5.0 mm Lidded SiP (System-in-Package)
- 24.9 x 24.9 x 4.4 mm Open-frame SiP
- Low profile LGA package
- -40° to +125°C Ambient temperature (see Figure 14)
- Efficiency >99%
- Connect in series for higher attenuation
- Pads for additional X filtering capacitance
- cTÜVus approved to UL/CSA 60950-1 and EN 60950-1
- CE marked to the LVD and RoHS Recast Directive as applicable



Figure 1 — QPI-21LZ (~1 in² area)

Applications

- ATCA blades
- Telecom base stations
- IBA & distributed power
- Network switches and routers
- Optical line-cards
- TD-SCMA wireless infrastructure

Typical Applications

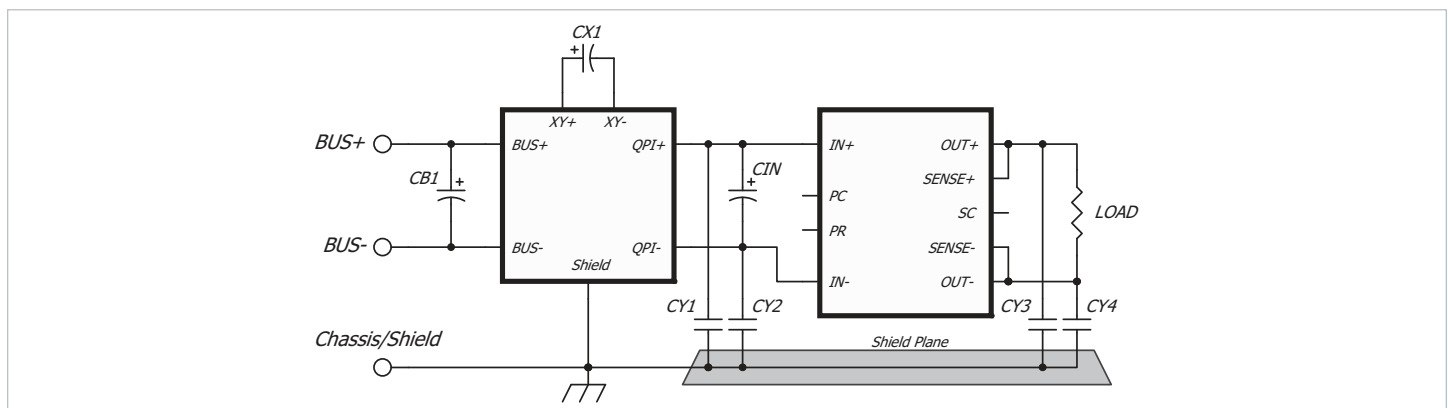

Figure 2 — Typical QPI-21 circuit with a Vicor brick converter. Optional X (CX1) filter capacitor shown.^[b]

^[b] CB1, CX1 capacitors, referenced in all schematics, are a 47µF electrolytic; United Chemi-Con EMVE101ARA470MKE0S or equivalent.

Order Information

Part Number	Part Number
QPI-21LZ ^[c]	QPI-21 LGA Package, RoHS Compliant
QPI-21LZ-01	QPI-21 LGA Package, RoHS Compliant, open frame package
	Evaluation Board Also Available
QPI-21-CB1	A QPI-21LZ mounted on a carrier board designed for use with DOSA compliant footprint dc-dc converters. Screw terminal blocks to allow for easy connection into an existing system.

Absolute Maximum Ratings

Exceeding these parameters may result in permanent damage to the product. CY1 to CY4, referenced in all schematics, are 4.7nF hi-voltage safety capacitors; Vishay VY1472M63Y5UQ63V0 or equivalent. CIN is the converter manufacturer's recommended value for input capacitor.

Name	Rating
Input Voltage, BUS+ to BUS-, continuous	-80 to 80 Vdc
Input Voltage, BUS+ to BUS-, 100 ms transient	-100 to 100 Vdc
BUS+/- BUS- to Shield pads, hi-pot	-1500 to 1500 Vdc
Input to output current, continuous @ 25°C T _A	14 Adc
Input to output current, 10 seconds @ 25°C T _A	20 Adc
Power dissipation, @ 65°C T _A , 14 A ^[d]	2.9 W
Operating temperature - T _A	-40 to 125°C
Thermal resistance ^[d] - R _{θJ-A} , using PCB layout in Figure 24	20°C/W
Thermal resistance ^[d] - R _{θJ-PCB}	8°C/W
Storage temperature, JEDEC Standard J-STD-033B	-55 to 125°C
Reflow temperature, 20 s exposure	245°C
ESD, Human body model (HBM)	-2000 to 2000 V

Electrical Characteristics

Parameter limits apply over the operating temp. range, unless otherwise noted.

Parameter	Conditions	Min	Typ	Max	Unit
BUS+ to BUS- input range	Measured at 14 A, 65°C ambient temperature ^[d]	30		80	Vdc
BUS+ to QPI+ voltage drop	Measured at 14 A, 65°C ambient temperature ^[d]			156	mVdc
BUS- to QPI- voltage drop	Measured at 14 A, 65°C ambient temperature ^[d]			50	mVdc
Common mode attenuation	V _{BUS} = 48 V, Frequency = 250 KHz, line impedance = 50 Ω		45		dB
Differential mode attenuation	V _{BUS} = 48 V, Frequency = 250 KHz, line impedance = 50 Ω		80		dB
Input bias current at 80 V	Input current from BUS+ to BUS-		8		mA

^[c] QPI-21LZ is a non-hermetically sealed package. Please read the "Post Solder Cleaning" section on Page 14.

^[d] See Figure 14 for the current de-rating curve.

Pad Descriptions

Pin Name	Name	Description
12, 13, 14	BUS+	Positive bus potential
1, 5, 16	BUS-	Negative bus potential
7, 8, 9	QPI+	Positive input to the converter
4, 5, 6	QPI-	Negative input to the converter
2, 3	Shield	Shield connects to the system chassis or to a safety ground.
10	XY-	Negative rail node for additional X filtering capacitance. Adding Y capacitors from this pin to ground is not recommended.
11	XY+	Positive rail node for additional X capacitance. Adding Y capacitors from this pin to ground is not recommended.

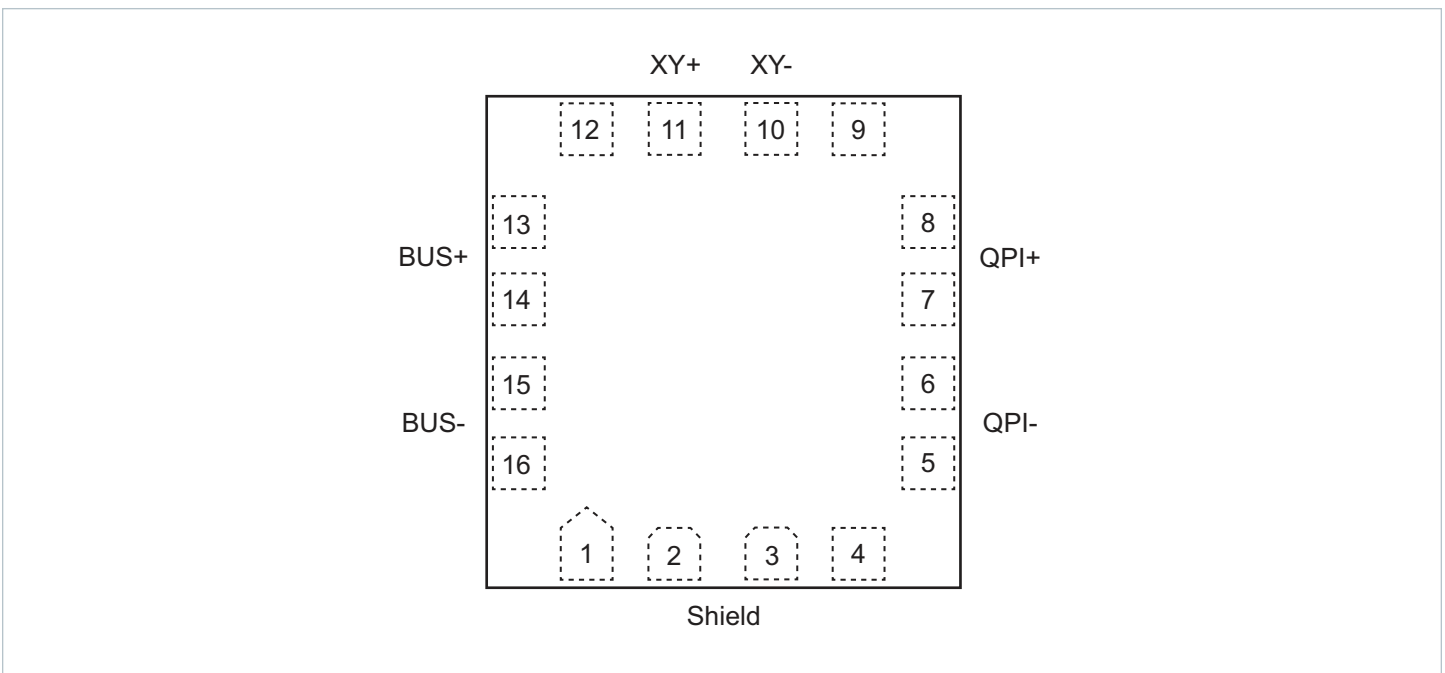

Applications Information

EMI Sources

Many of the components in today's power conversion modules are sources of high-frequency EMI noise generation. Diodes, high-frequency switching devices, transformers and inductors, and circuit layouts passing high dv/dt or di/dt signals are all potential sources of EMI.

EMI is propagated either by radiated or conductive means. Radiated EMI can be sourced from these components as well as by circuit loops that act like antennas and broadcast the noise signals to neighboring circuit paths. This also means that these loops can act as receivers of a broadcasted signal. This radiated EMI noise can be reduced by proper circuit layout and by shielding potential sources of EMI transmission.

There are two basic forms of conducted EMI that typically need to be filtered; namely common-mode (CM) and differential-mode (DM) EMI. Differential-mode resides in the normal power loop of a power source and its load; where the signal travels from the source to the load and then returns to the source. Common-mode is a signal that travels through both leads of the source and is returned to earth via parasitic pathways, either capacitively or inductively coupled.

Figure 6 to Figure 9 are the resulting EMI plots, after filtering by the QPI-21, of the total noise, both common and differential mode, of a DOSA (Distributed-power Open Standards Alliance) compliant converter. These converters are mounted on a QPI-21 evaluation board and tested under various loads. The red and blue traces represent the positive and negative branches of total noise, as measured using an industry standard LISN setup, as is shown in Figures 11 to 13.

Differential-mode EMI is typically larger in magnitude than common-mode, since common-mode is produced by the physical imbalances in the differential loop path. Reducing differential EMI will cause a reduction in common-mode EMI.

Passive EMI Filtering

The basic premise of filtering EMI is to insert a high-impedance, at the EMI's base frequency, in both the differential and common-mode paths as it returns to the power source. Passive filters use common-mode chokes and "Y" capacitors to filter out common-mode EMI. These chokes are designed to present a high-impedance at the EMI frequency in series with the return path, and a low impedance path to the earth signal via the "Y" caps. This network will force the EMI signals to re-circulate within a confined area and not to propagate to the outside world. Often two common-mode networks are required to filter EMI within the frequency span required to pass the EN55022 class B limits.

The other component of the passive filter is the differential LC network. Again, the inductor is chosen such that it will present a high-impedance in the differential EMI loop at the EMI's base frequency. The differential capacitor will then shunt the EMI back to its source. The QPI-21 was specifically designed to work with conventional switching frequency converters like Vicor's Brick products; Micro, Mini and Maxi modules; as well as converters from various vendors.

Active EMI Filtering

The QPI-21 active EMI filter uses the same basic principles for filtering as the passive approach, but its active common-mode filter can perform as well as a passive filter, when filtering lower frequencies, in much less board area and power dissipation.

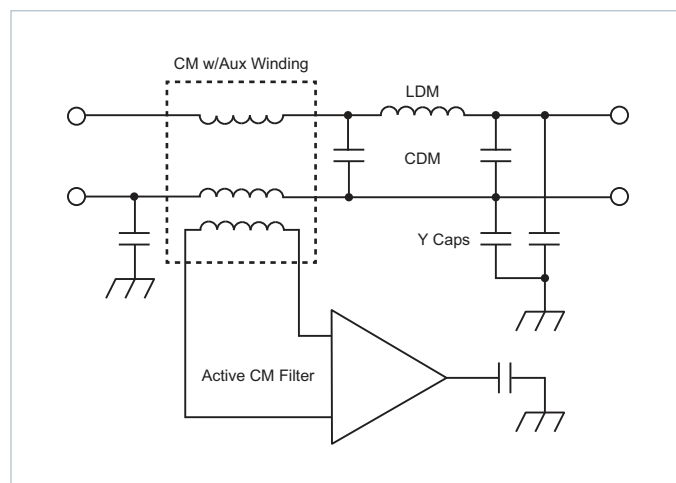

Figure 3 — Simplified Active EMI filter circuit

Typically, the lower the frequency the greater the needed inductance would be to properly filter the EMI signal. This means either a larger core or a greater number of turns on a smaller core. A larger core requires more board space, where a smaller core with more turns has a greater amount of unwanted parasitics that can affect the filters ability to attenuate EMI signals.

Figure 3 is a simplified schematic of the QPI-21's active and passive circuitry used for EMI filtering. The QPI-21's active filter uses a small high-frequency common-mode transformer to filter the higher frequencies and adds a sensing element to

it so that the lower frequency common mode signal can be sensed and a correction signal can be generated and inserted into the shield connection. By this means, the QPI-21 is capable of providing EMI filtering of converters in far less space than standard passive filters and can provide filtering over the entire EN55022 class B range.

EMI Management

The more effectively EMI is managed at the source, namely the power converter, the less EMI attenuation will be required to meet a given standard. The addition of "Y" capacitors to the input and output power nodes of the converter will help to limit the amount of common mode EMI that will propagate to the input source.

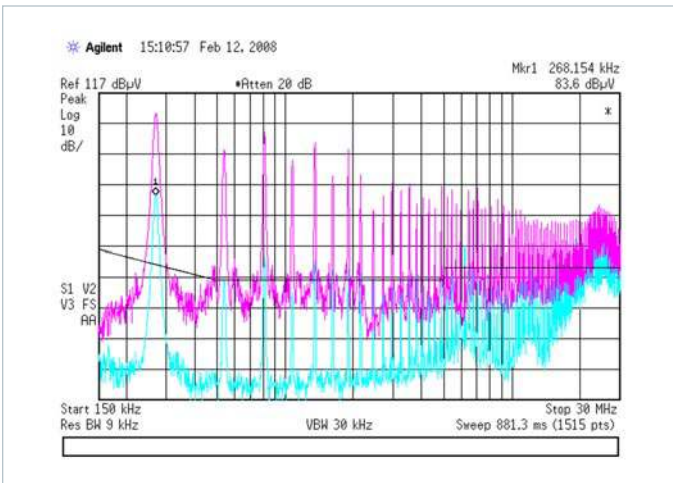

Figure 4 — An unfiltered converter’s response to “open-frame” (light blue) and “base-plate” (purple) EMI configurations

There are two basic topologies for the connection of the re-circulating “Y” capacitors, referred to as “open-frame” and “base-plate”. Figure 4 illustrates how a converter’s total conducted noise

profile can vary with one topology versus another. The EMI generated by the “base-plate” configuration is much greater than that generated by the “open-frame” in this example. Selecting the right topology will greatly reduce the amount of EMI signal that needs to be filtered.

Figure 2 shows the base-plate topology of re-circulating “Y” capacitors. Here, CY1 to CY4 are connected to each power node of the dc-dc converter, and then are connected together on a copper shield plane created under the converter. The addition of the copper shield plane helps in the containment of the radiated EMI, converting it back to conducted EMI and shunting it back to its source.

In Figure 5, the open-frame topology is shown where the “Y” capacitors (CY1 and CY2) re-circulate the EMI signals between the positive input and output, and the negative input and output nodes of the power conversion stage. Safety and system requirements may dictate that some converters must have the output return (-) directly connected to earth ground. This connection can impact performance of some filter solutions, where the QPI-21 works well in this configuration.

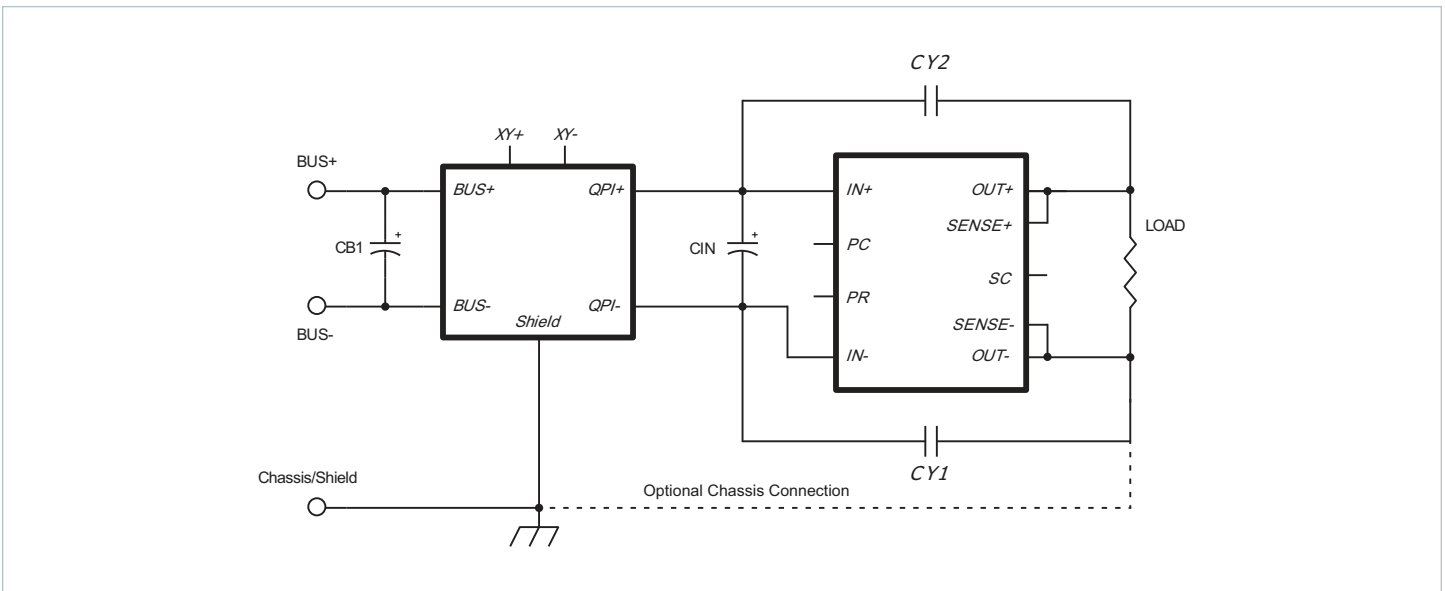

Figure 5 — Typical “open-frame” application with an optional connection of the chassis to OUT- of the converter

Attenuation Plots — All converters have their output ground connected to chassis/earth ground.

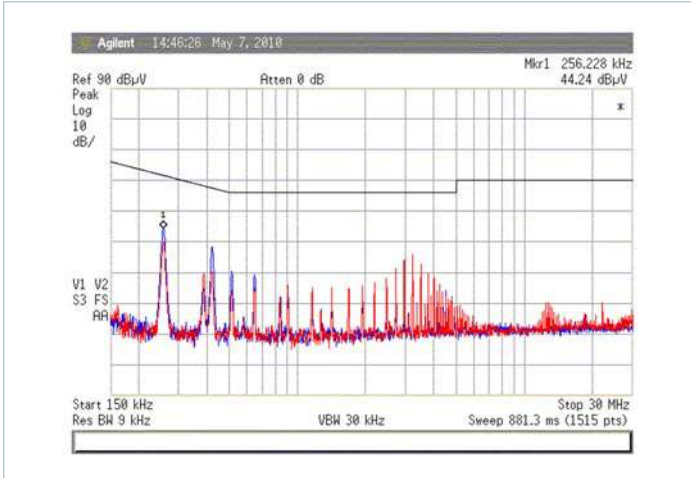

Figure 6 — Ericsson PKM 4402NG using open-frame “Y” capacitors on QPI-21-CB1 evaluation board, 414 W load

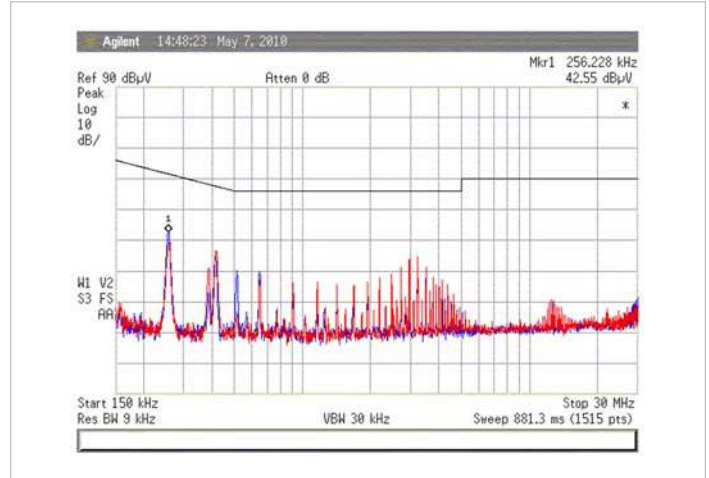

Figure 7 — Ericsson PKM 4402NG using open-frame “Y” capacitors on QPI-21-CB1 evaluation board, 414 W load, converter’s output ground connected to earth

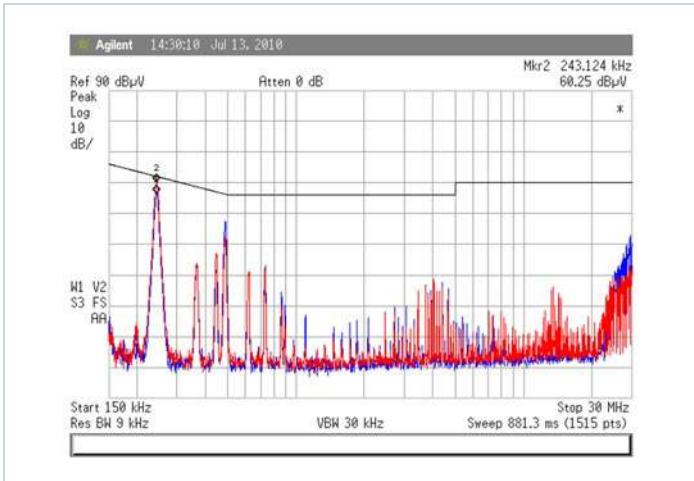

Figure 8 — Ericsson PKM4304B PI using base-plate “Y” capacitors with a 360 W load

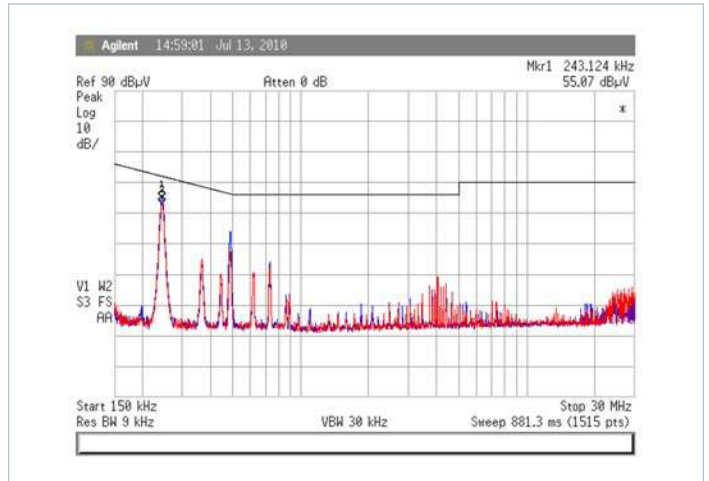

Figure 9 — Ericsson PKM4304B PI using base-plate “Y” capacitors with a 360 W load, CX1 = 47μF (see Figure 2).

The EMI results shown in Figures 6 and 7 are of the total noise measured using the QPI-21 in an “open-frame” topology, as shown in Figure 5, with and without the converter’s ground tied to chassis/earth.

The EMI results shown in Figures 8 and 9 are of the total noise measured using the QPI-21 in a “base-plate” topology, as shown in Figure 2, with and without the optional CX1 capacitor in use.

Using EMI splitters, the peak EMI at the fundamental switching frequency was determined to be mostly differential mode current. The addition of a 47 μF capacitor reduced the total peak by about 6dBuV, as shown in Figure 10.

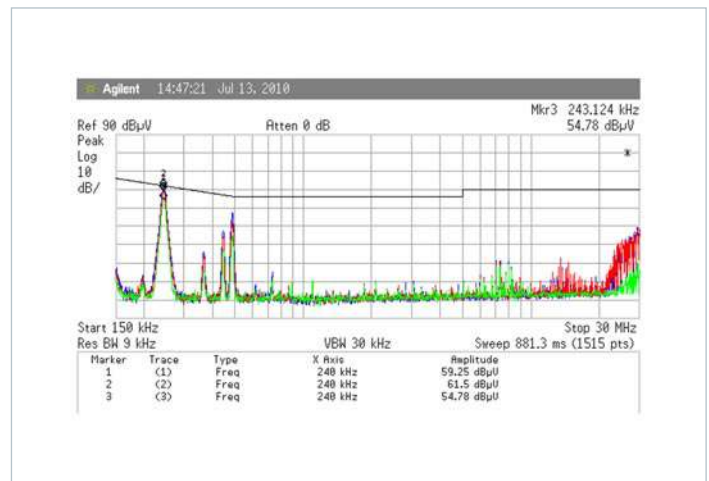

Figure 10 — CM Peak Measurements with a 10 μF and 47 μF CX1 capacitor

Attenuation Test Setups

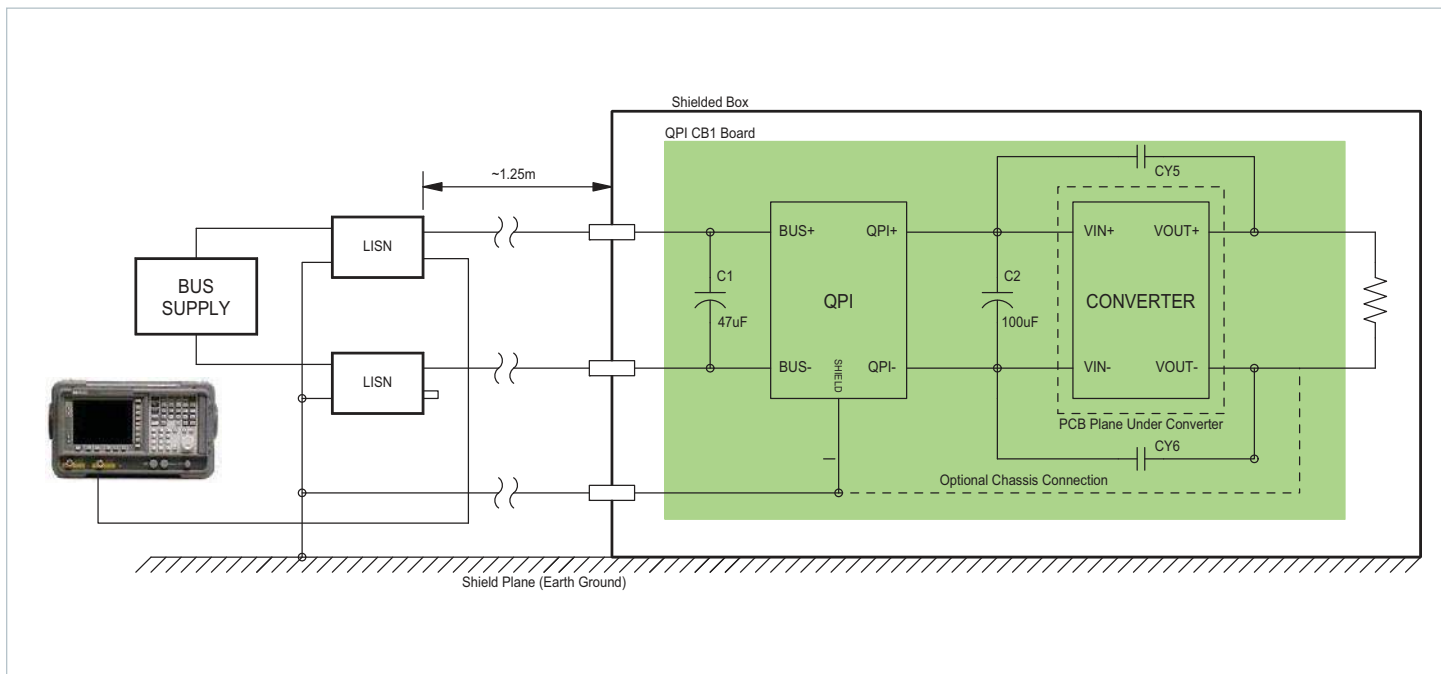

Figure 11 — Open-frame EMI test setup using the QPI-21-CB1 carrier board with 48V converter

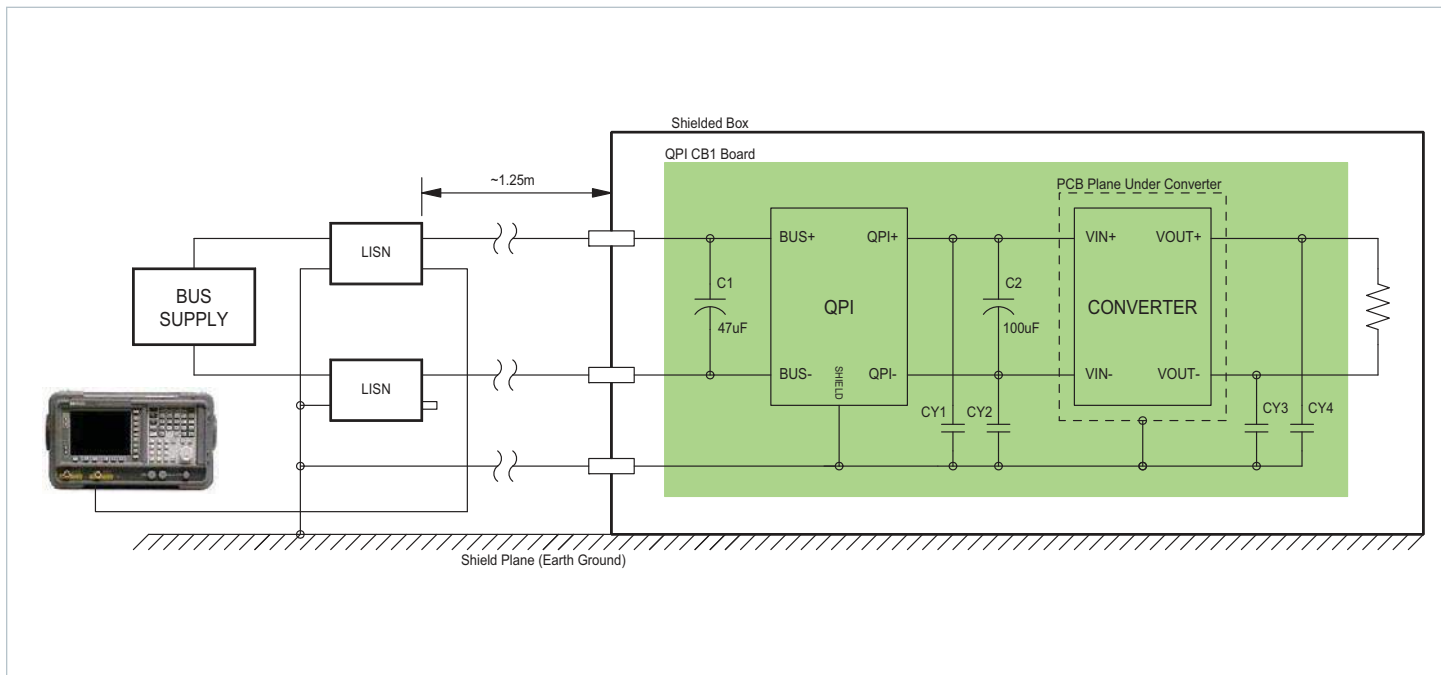

Figure 12 — Base-plate EMI test setup using the QPI-21-CB1 carrier board with 48V converter

Attenuation Test Setups

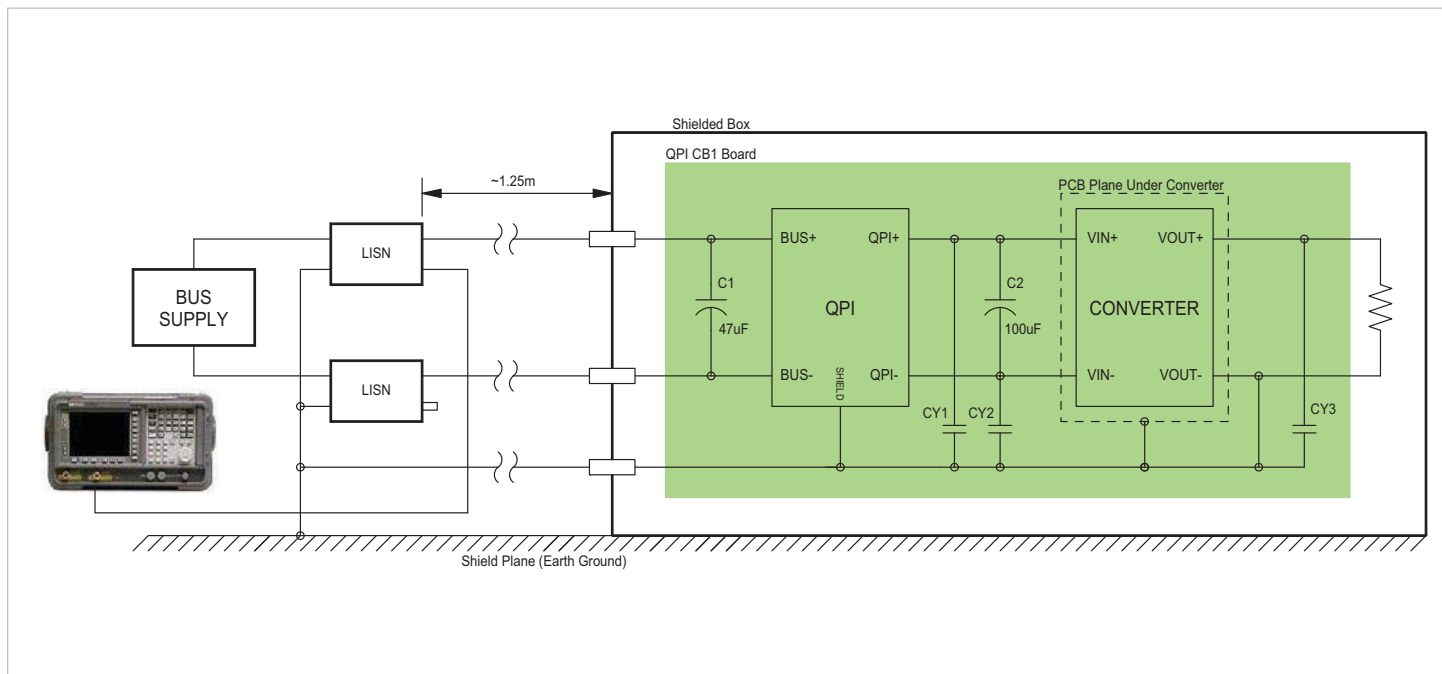

Figure 13 — Base-plate EMI test setup using the QPI-21-CB1 carrier board with 48 V converter

In Figures 11, 12 and 13, C1 is the required 47 uF capacitor (United Chemi-Con EMVE101ARA470MKE0S or equivalent), C2 is a converter input cap (value dependent on converter), and the CY

capacitors are high-voltage, 4.7 nF ceramics (Murata's GRM31BR73A472KW01L or equivalent).

Current De-Rating — Mounted to QPI-21-EVAL1 evaluation board.

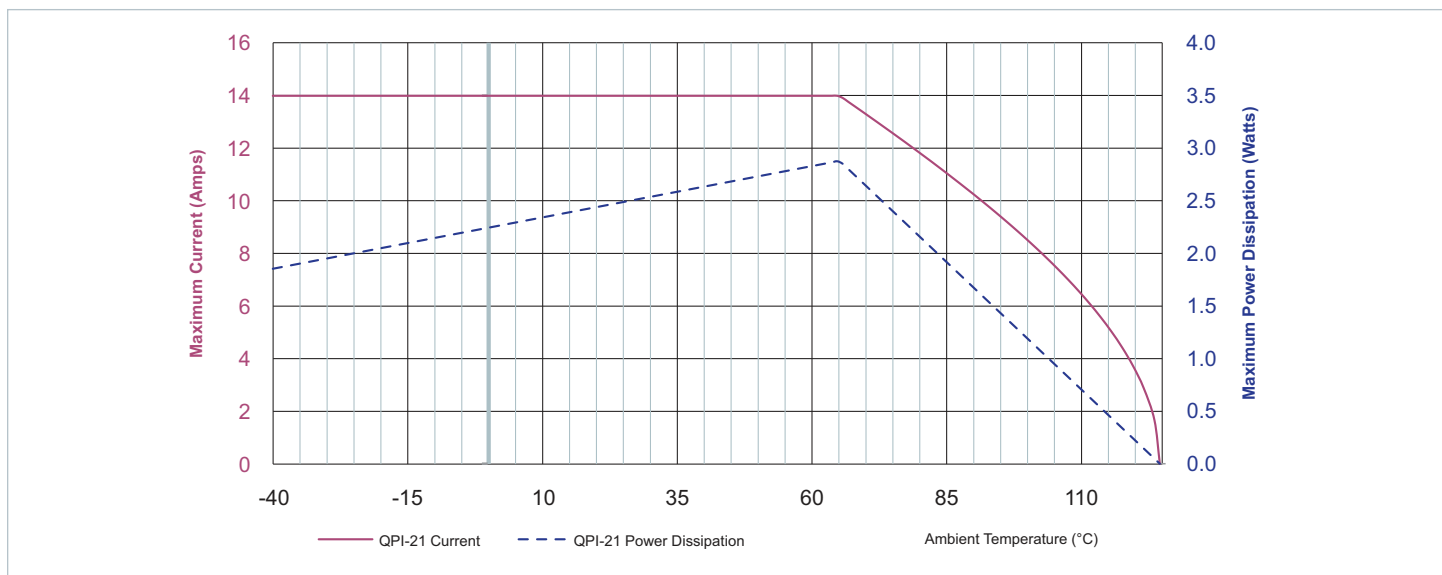

Figure 14 — Current de-rating and power dissipation over ambient temperature range

The de-rating curve in Figure 14 is based on the maximum allowable internal component temperature and the 14 A maximum rating of the QPI-21. The power dissipation curve is based on the current squared multiplied by the internal resistance between the inputs and

outputs of the filter. The internal resistance temperature coefficient is compensated for in the power dissipation curve. The left Y axis is in amps for the solid trace, the right Y axis is in watts for the dashed trace.

QPI Application Circuits — Filtering Dual Converters.

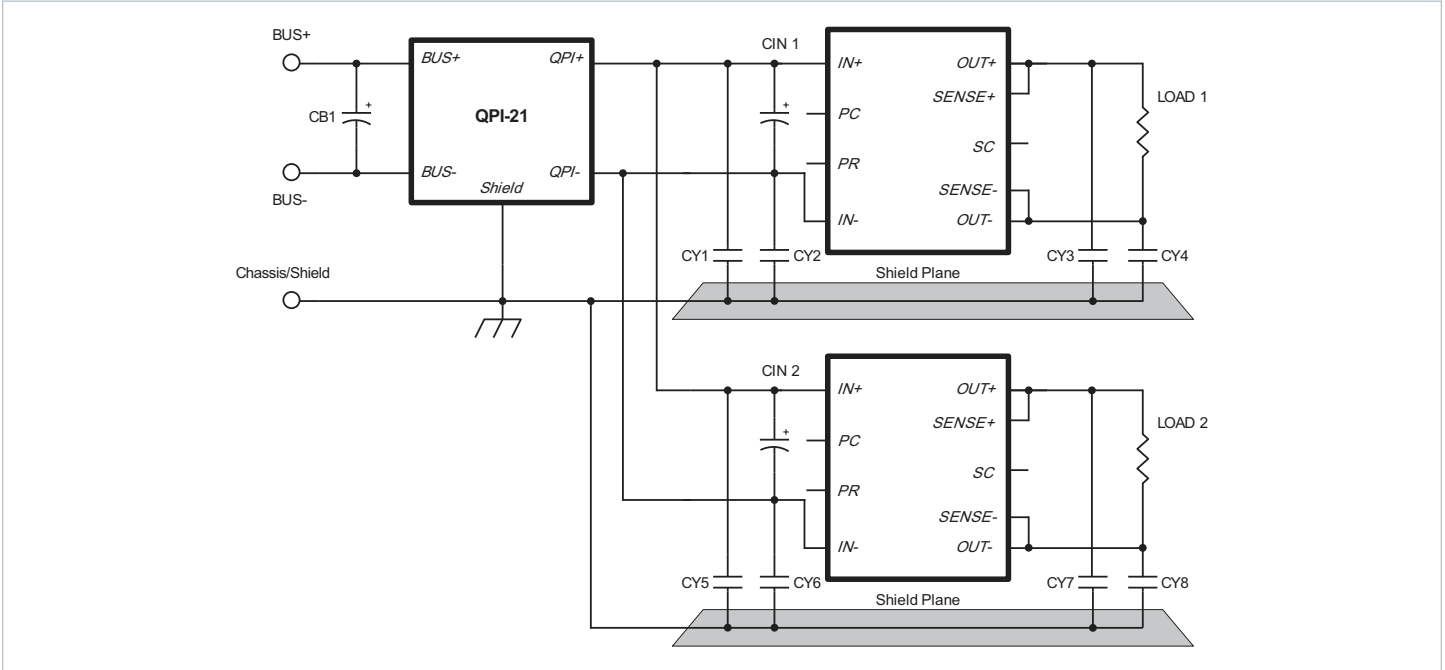

Figure 15 — The QPI-21 filtering dual supplies.^[e]

The shield plane under the two converters in Figure 15 should be one contiguous plane under both. The circuit in Figure 15 is capable of filtering more converters than shown, up to the maximum current limit of the QPI-21. In Figure 16, the QPI+ and QPI- outputs of each

filter should not be connected in parallel. The QPI-21 is not designed to be used in parallel with another QPI-21 to achieve a higher current rating, but it can be used multiple times within a system design.

QPI Application Circuits — Filtering Parallel Converters

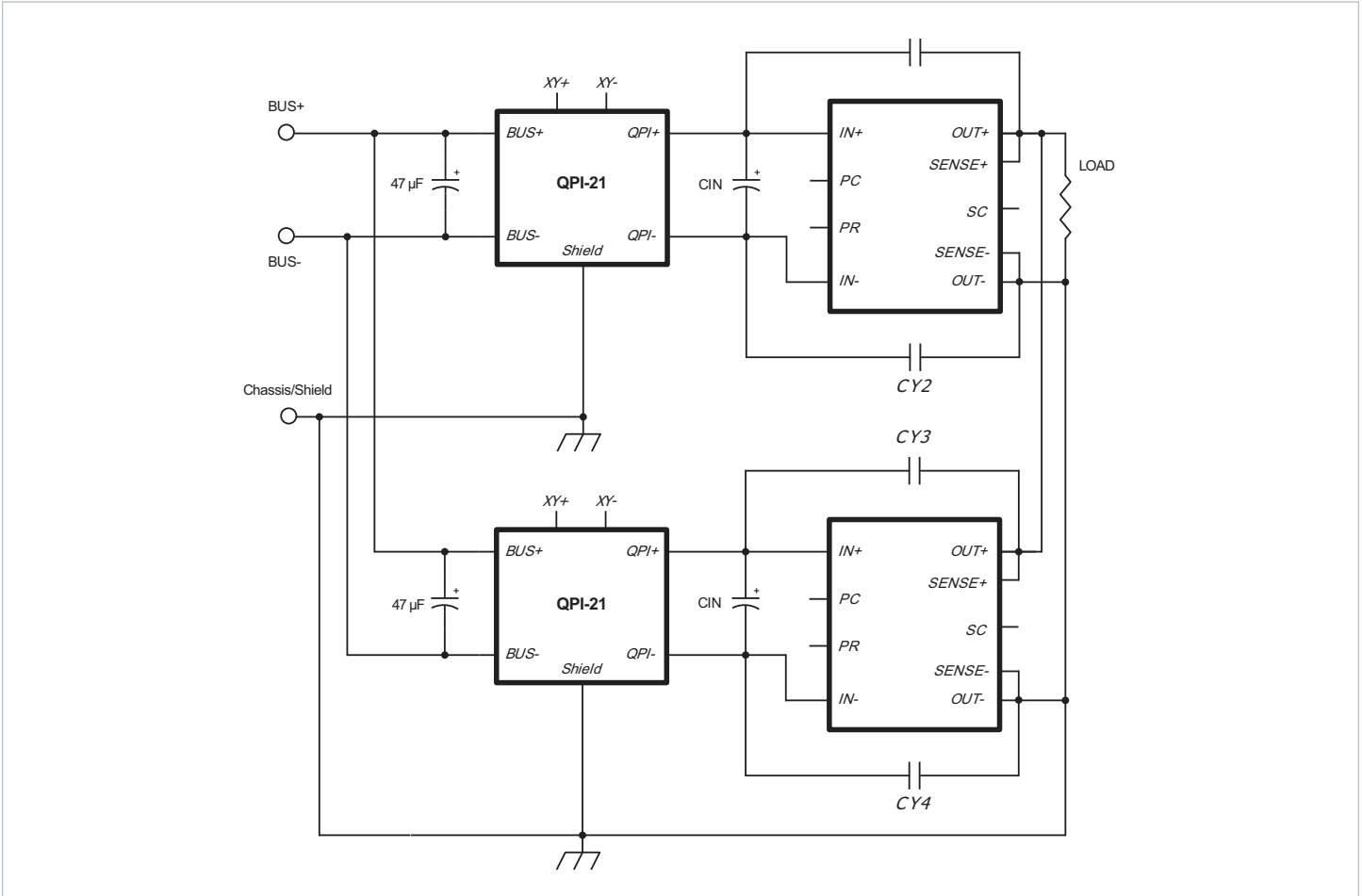

Figure 16 — Dual QPI-21's filtering paralleled converters feeding a common load.^[e]

^[e] CIN1 and CIN2, CY1 through CY8, should be the value and voltage rating recommended by the converter's manufacturer.

QPI Insertion Loss Measurements

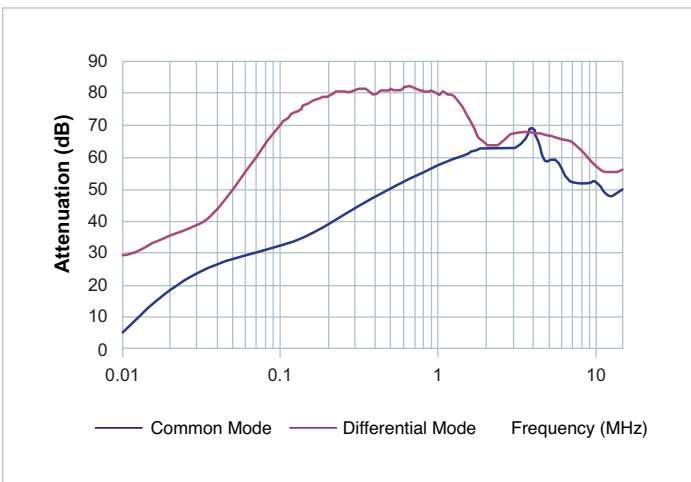

Figure 17 — Attenuation curves into a 50Ω line impedance, bias from a 48 V bus

QPI Insertion Loss Equation

$$Insertion_{Loss} = 20 \log \left(\frac{I_{INA}}{I_{INB}} \right)$$

QPI Insertion Loss Test Circuits

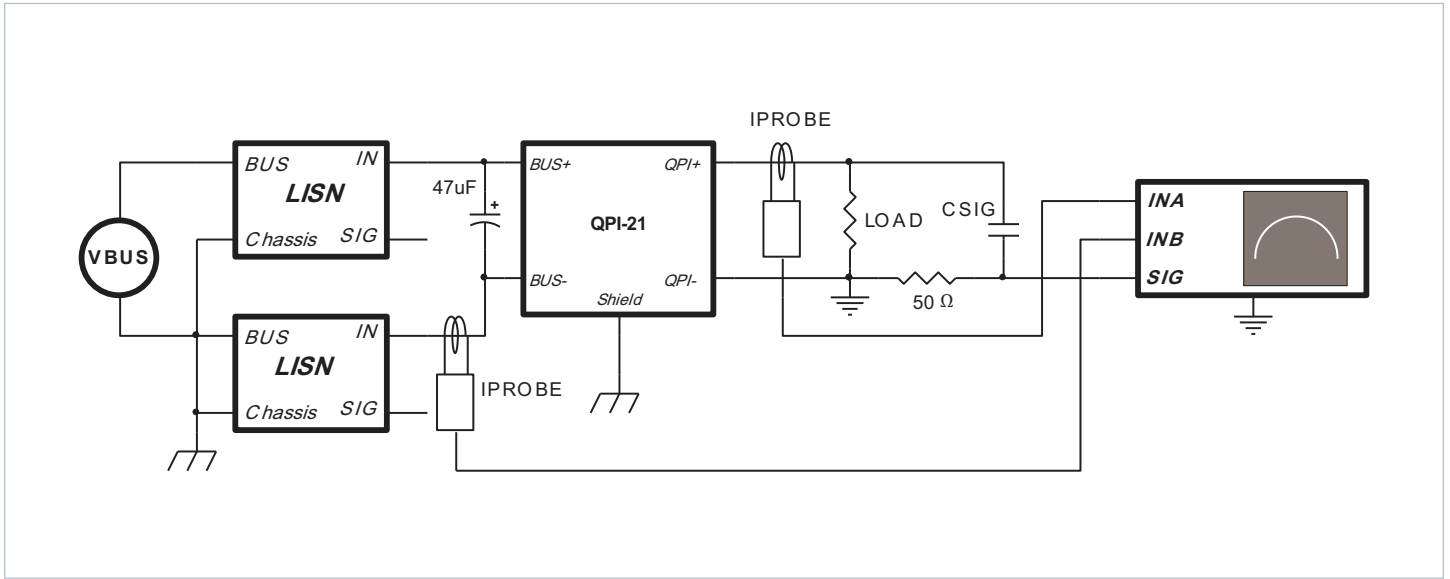

Figure 18 — Test Set-up to measure Differential Mode EMI currents in Figure 17.

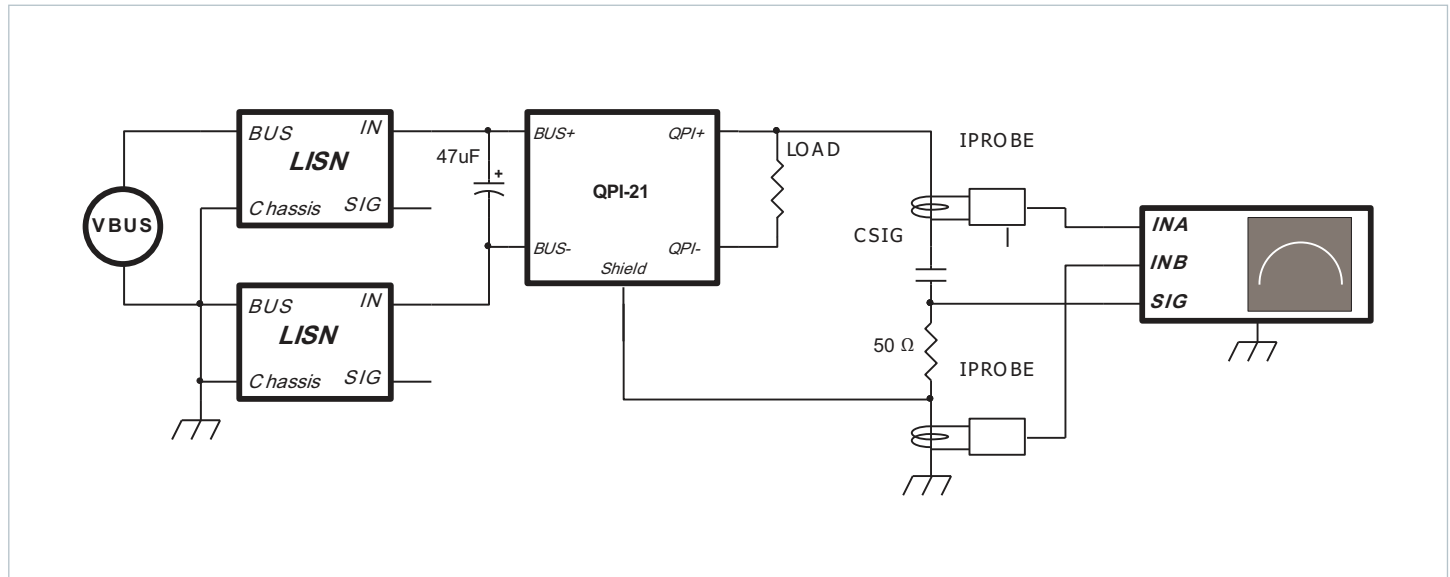

Figure 19 — Test Set-up to measure Common Mode EMI currents in Figure 17.

Mechanicals

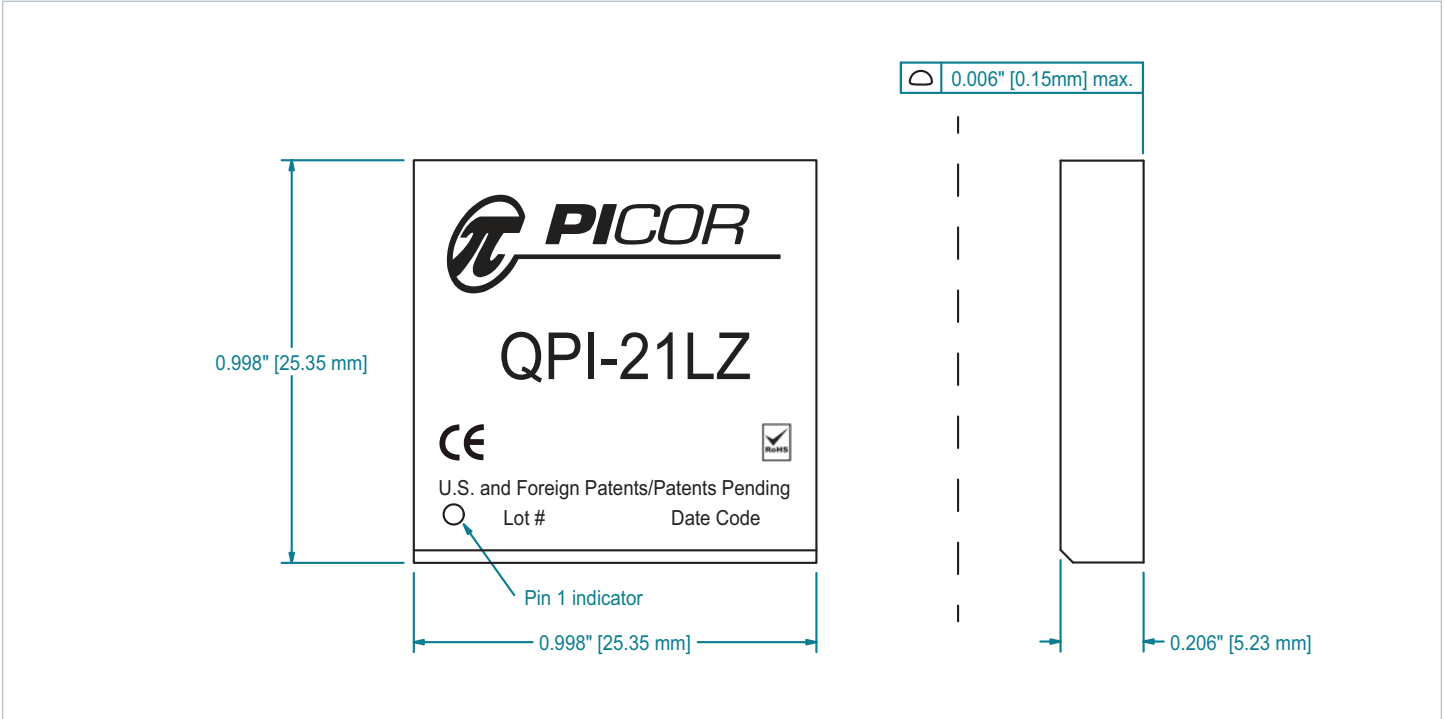

Figure 20 — Lidded Package Dimensions, tolerance of ± 0.004 "

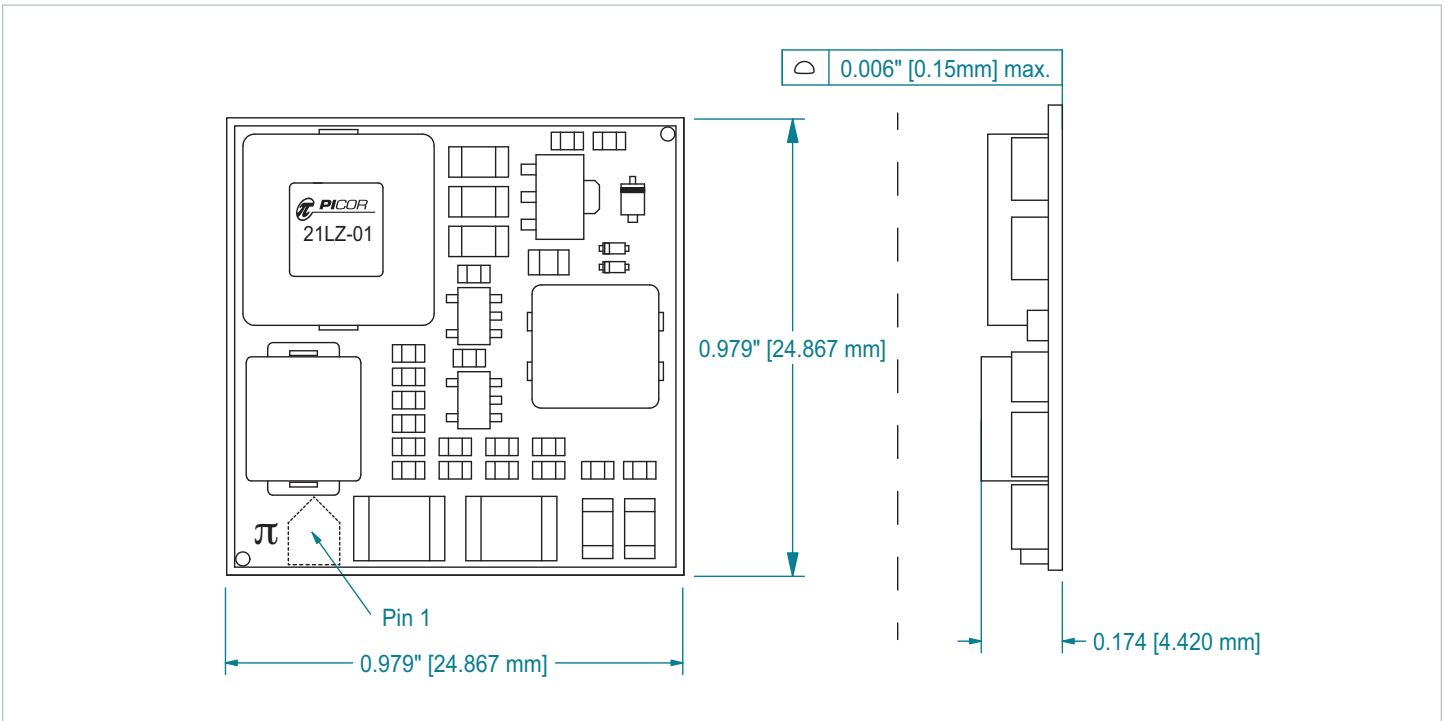

Figure 21 — Open-frame Package dimensions, tolerance of ± 0.004 ". Pick and Place from label center.

Pad and Stencil Definitions

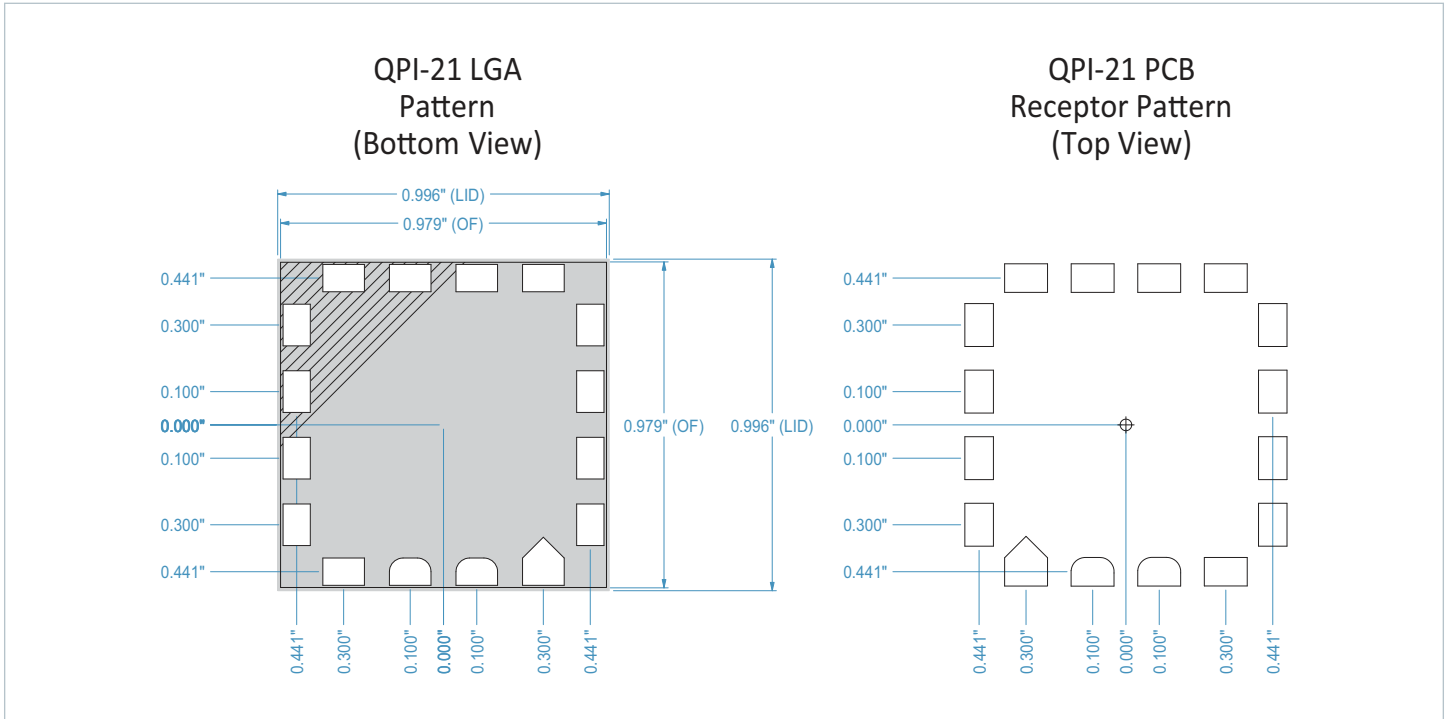

Figure 22 — Bottom view of open-frame (OF) and lidded (LID) products. (All dimensions are in inches.)

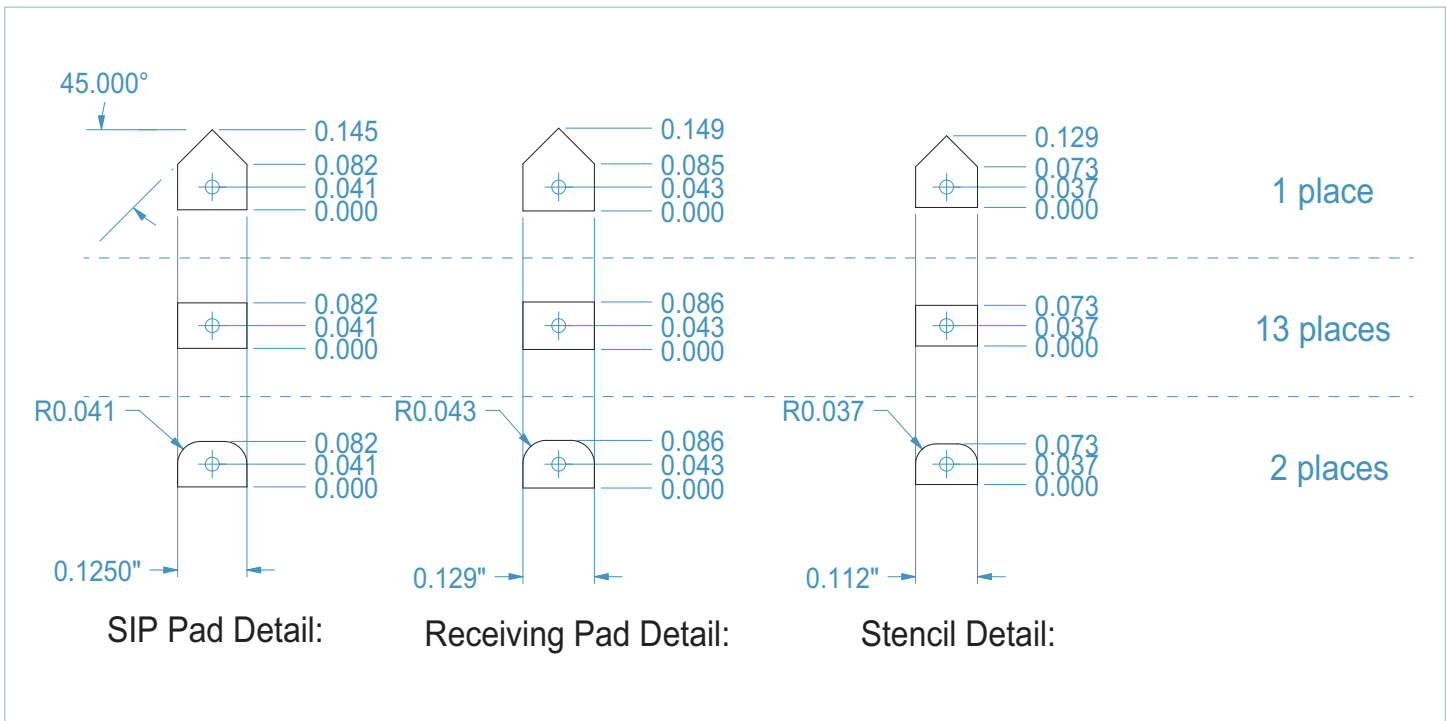

Figure 23 — Recommended receptor and stencil patterns. (All dimensions are in inches.)

Stencil definition is based on a 6mil stencil thickness, 80% of LGA pad area coverage. LGA Package dimensions are for both the

Open-Frame and Lidded versions of the QPI-21.

QPI-21 PCB Layout Recommendations

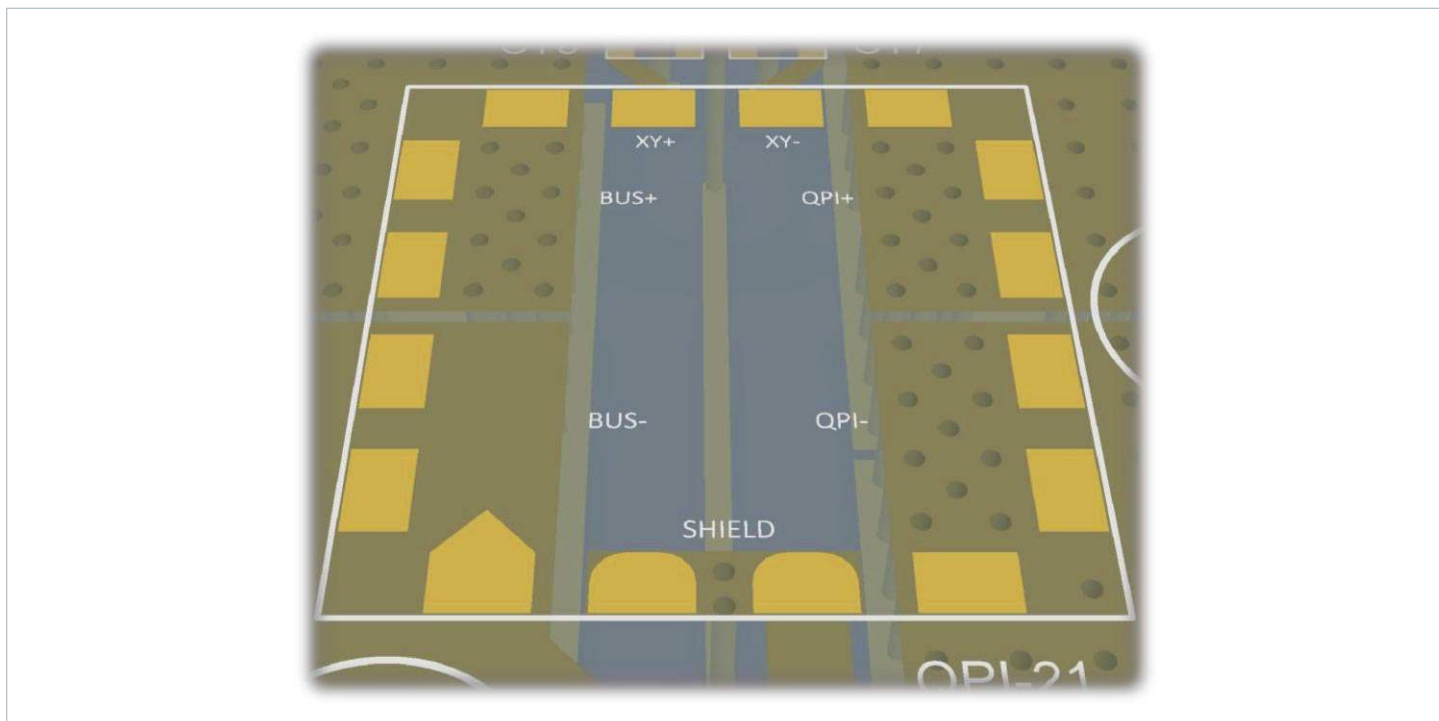

Figure 24 — 3D view of paralleling planes underneath the QPI-21

PCB Layout

When laying out the QPI-21 EMI filter it is important for the designer to be aware of the radiated EMI field that all converters emit and to place the QPI-21 outside of this field area. It is also recommended that the bus lines feeding into the QPI filter are not routed such that they lie between the QPI and the converter, or that their copper planes over-lap on inner layers. This can cause EMI noise to be coupled from input to output via the parasitic capacitance between the planes.

When using converters that have a large field of radiated EMI surrounding them, the QPI-21 must be located outside of this area of radiation, with the BUS voltage pins located on the side farthest away from the converter. This is to keep the radiated EMI from by-passing the filter and coupling directly to the BUS feeds.

Post Solder Cleaning

The LZ version QP SIPs are not hermetically sealed and must not be exposed to liquid, including but not limited to cleaning solvents, aqueous washing solutions or pressurized sprays. When soldering, it is recommended that no-clean flux solder be used, as this will ensure that potentially corrosive mobile ions will not remain on, around, or under the module following the soldering process. For applications where the end product must be cleaned in a liquid solvent, Picor recommends using the QPI-21LZ-01, open-frame version of the EMI filter.

QPI-21 Mechanical Data

Datum	Units	QPI-21LZ	QPI-21LZ-01	Notes
FITS	Failure/Billion Hrs.	208	208	FITS based on the BellCore Standard TR-332
MTBF	Million Hrs.	4.8	4.8	MTBFs based on the BellCore Standard TR-332
Weight	grams	6.5	5.2	
MSL		3	3	
Peak reflow Temperature	°C/20 seconds	245	245	IPC/JEDEC J-STD-020D

Vicor's comprehensive line of power solutions includes high density AC-DC and DC-DC modules and accessory components, fully configurable AC-DC and DC-DC power supplies, and complete custom power systems.

Information furnished by Vicor is believed to be accurate and reliable. However, no responsibility is assumed by Vicor for its use. Vicor makes no representations or warranties with respect to the accuracy or completeness of the contents of this publication. Vicor reserves the right to make changes to any products, specifications, and product descriptions at any time without notice. Information published by Vicor has been checked and is believed to be accurate at the time it was printed; however, Vicor assumes no responsibility for inaccuracies. Testing and other quality controls are used to the extent Vicor deems necessary to support Vicor's product warranty. Except where mandated by government requirements, testing of all parameters of each product is not necessarily performed.

Specifications are subject to change without notice.

Vicor's Standard Terms and Conditions

All sales are subject to Vicor's Standard Terms and Conditions of Sale, which are available on Vicor's website or upon request.

Product Warranty

In Vicor's standard terms and conditions of sale, Vicor warrants that its products are free from non-conformity to its Standard Specifications (the "Express Limited Warranty"). This warranty is extended only to the original Buyer for the period expiring two (2) years after the date of shipment and is not transferable.

UNLESS OTHERWISE EXPRESSLY STATED IN A WRITTEN SALES AGREEMENT SIGNED BY A DULY AUTHORIZED VICOR SIGNATORY, VICOR DISCLAIMS ALL REPRESENTATIONS, LIABILITIES, AND WARRANTIES OF ANY KIND (WHETHER ARISING BY IMPLICATION OR BY OPERATION OF LAW) WITH RESPECT TO THE PRODUCTS, INCLUDING, WITHOUT LIMITATION, ANY WARRANTIES OR REPRESENTATIONS AS TO MERCHANTABILITY, FITNESS FOR PARTICULAR PURPOSE, INFRINGEMENT OF ANY PATENT, COPYRIGHT, OR OTHER INTELLECTUAL PROPERTY RIGHT, OR ANY OTHER MATTER.

This warranty does not extend to products subjected to misuse, accident, or improper application, maintenance, or storage. Vicor shall not be liable for collateral or consequential damage. Vicor disclaims any and all liability arising out of the application or use of any product or circuit and assumes no liability for applications assistance or buyer product design. Buyers are responsible for their products and applications using Vicor products and components. Prior to using or distributing any products that include Vicor components, buyers should provide adequate design, testing and operating safeguards.

Vicor will repair or replace defective products in accordance with its own best judgment. For service under this warranty, the buyer must contact Vicor to obtain a Return Material Authorization (RMA) number and shipping instructions. Products returned without prior authorization will be returned to the buyer. The buyer will pay all charges incurred in returning the product to the factory. Vicor will pay all reshipment charges if the product was defective within the terms of this warranty.

Life Support Policy

VICOR'S PRODUCTS ARE NOT AUTHORIZED FOR USE AS CRITICAL COMPONENTS IN LIFE SUPPORT DEVICES OR SYSTEMS WITHOUT THE EXPRESS PRIOR WRITTEN APPROVAL OF THE CHIEF EXECUTIVE OFFICER AND GENERAL COUNSEL OF VICOR CORPORATION. As used herein, life support devices or systems are devices which (a) are intended for surgical implant into the body, or (b) support or sustain life and whose failure to perform when properly used in accordance with instructions for use provided in the labeling can be reasonably expected to result in a significant injury to the user. A critical component is any component in a life support device or system whose failure to perform can be reasonably expected to cause the failure of the life support device or system or to affect its safety or effectiveness. Per Vicor Terms and Conditions of Sale, the user of Vicor products and components in life support applications assumes all risks of such use and indemnifies Vicor against all liability and damages.

Intellectual Property Notice

Vicor and its subsidiaries own Intellectual Property (including issued U.S. and Foreign Patents and pending patent applications) relating to the products described in this data sheet. No license, whether express, implied, or arising by estoppel or otherwise, to any intellectual property rights is granted by this document. Interested parties should contact Vicor's Intellectual Property Department.

The products described on this data sheet are protected by the following U.S. Patents Number:
6,898,092

Vicor Corporation
25 Frontage Road
Andover, MA 01810 USA

Picor Corporation
51 Industrial Drive
North Smithfield, RI 02896 USA

email

Customer Service: custserv@vicorpower.com

Technical Support: apps@vicorpower.com