

REVISONS		DATE	OWN	APVD
2	REV PER ECO-12-003474	23FEB2012	MBH	RH
3	REV PER ECO-12-004619	08MAR2012	MBH	RH
A	REV PER ECO-13-005117	28MAR2013	VP	RH
A1	REVISED PER ECO-20-012096	27AUG2020	CN	HC

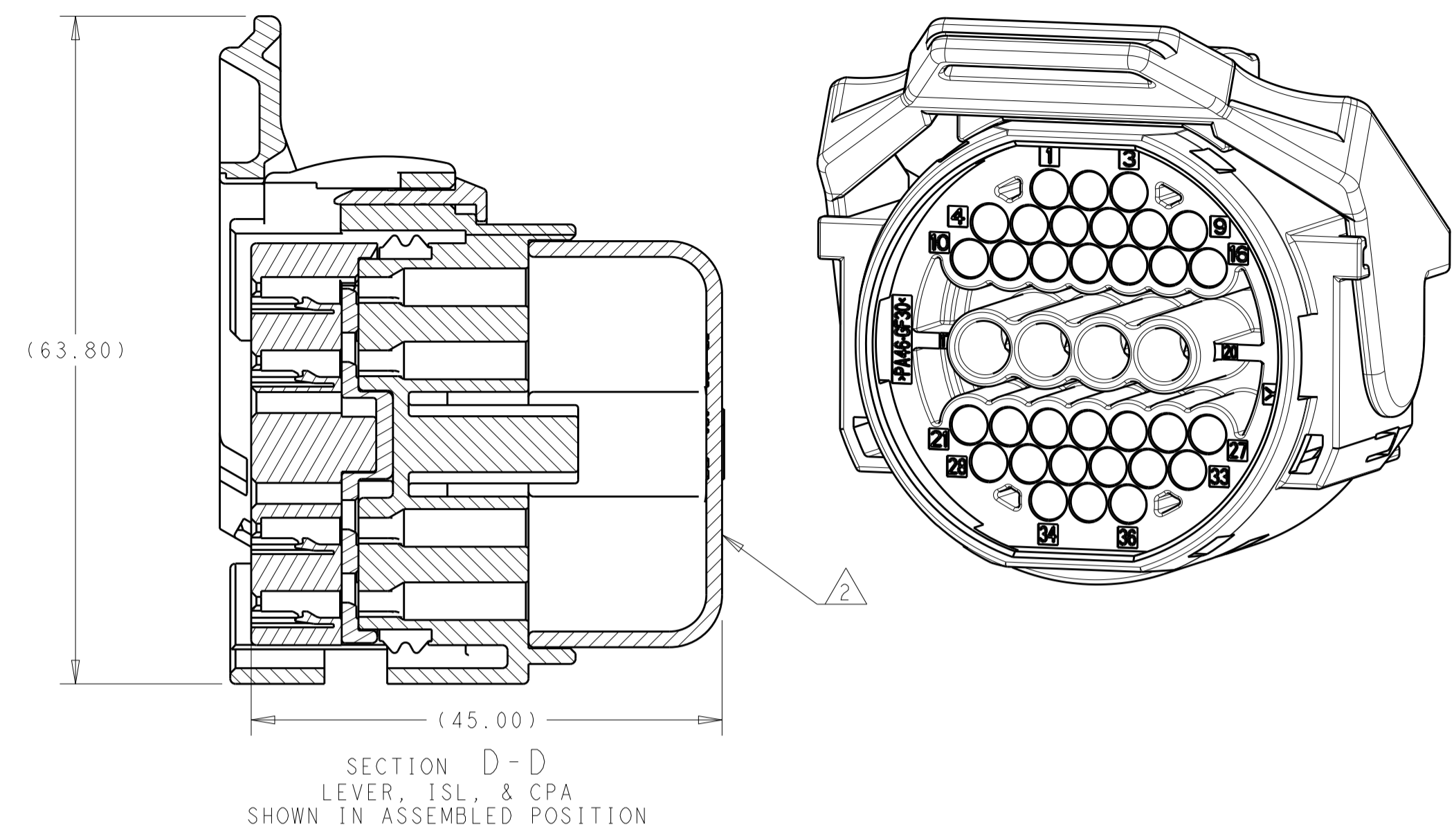

TE PART #	FINISH	WIRE SIZE	DESCRIPTION
1418844-1	Sn	0.25-0.35mm ²	MCON 1.2 RECEPTACLE
	Sn	22AWG	MCON 1.2 RECEPTACLE
1670146-1	Sn	0.50-0.75mm ²	MCON 1.2 RECEPTACLE
1418850-1	Sn	1.0-1.5mm ²	MCON 1.2 RECEPTACLE
1241392-1	Sn	0.20-0.35mm ²	MCP 2.8K RECEPTACLE
1241394-1	Sn	0.50-1.00mm ²	MCP 2.8K RECEPTACLE
1241396-1	Sn	1.00-2.50mm ²	MCP 2.8K RECEPTACLE

WIRE SEAL #	INSULATION RANGE	TERMINAL SYSTEM
967067-2	0.9-1.4	MCON 1.2
967067-1	1.4-2.1	
963294-1	1.2-2.0	MCP 2.8K
963293-1	2.0-2.7	
963292-1	2.7-3.0	

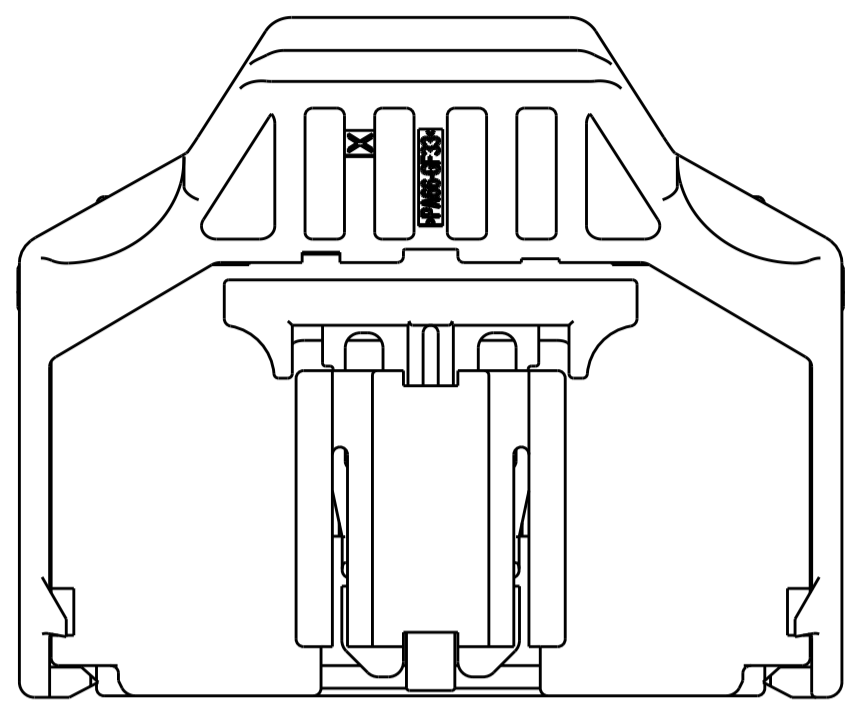
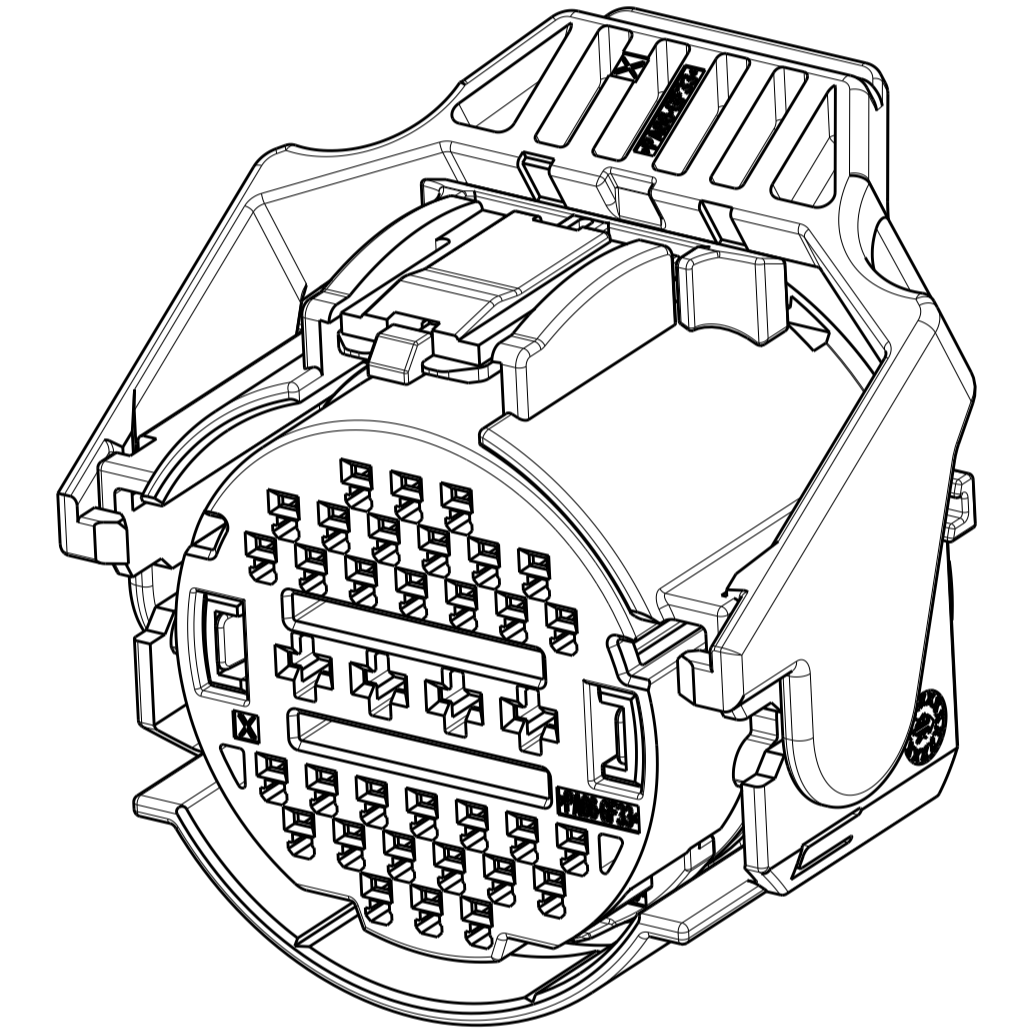
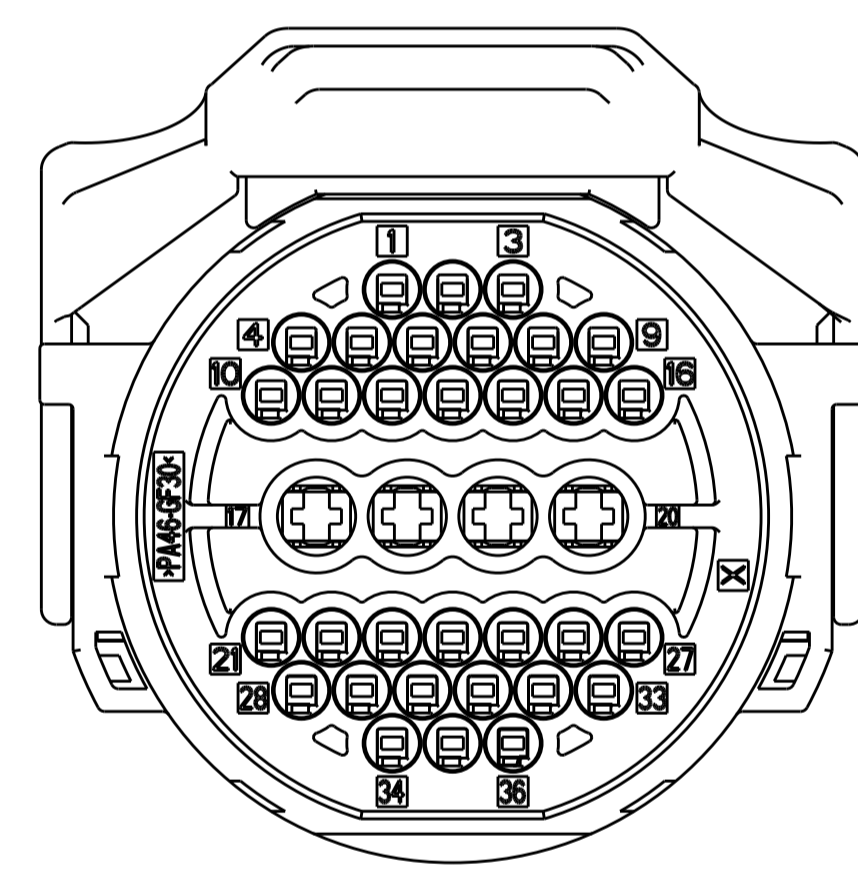
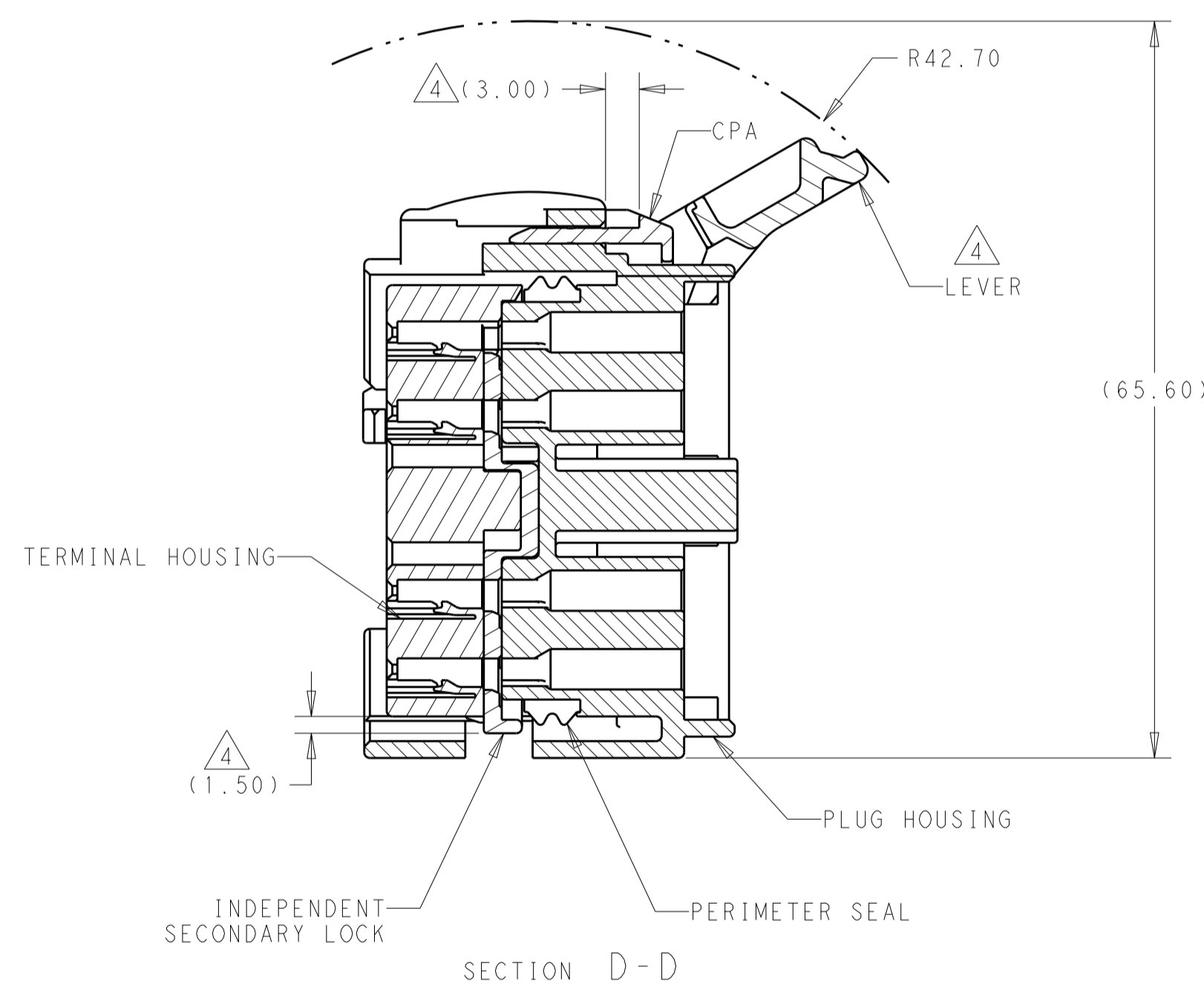
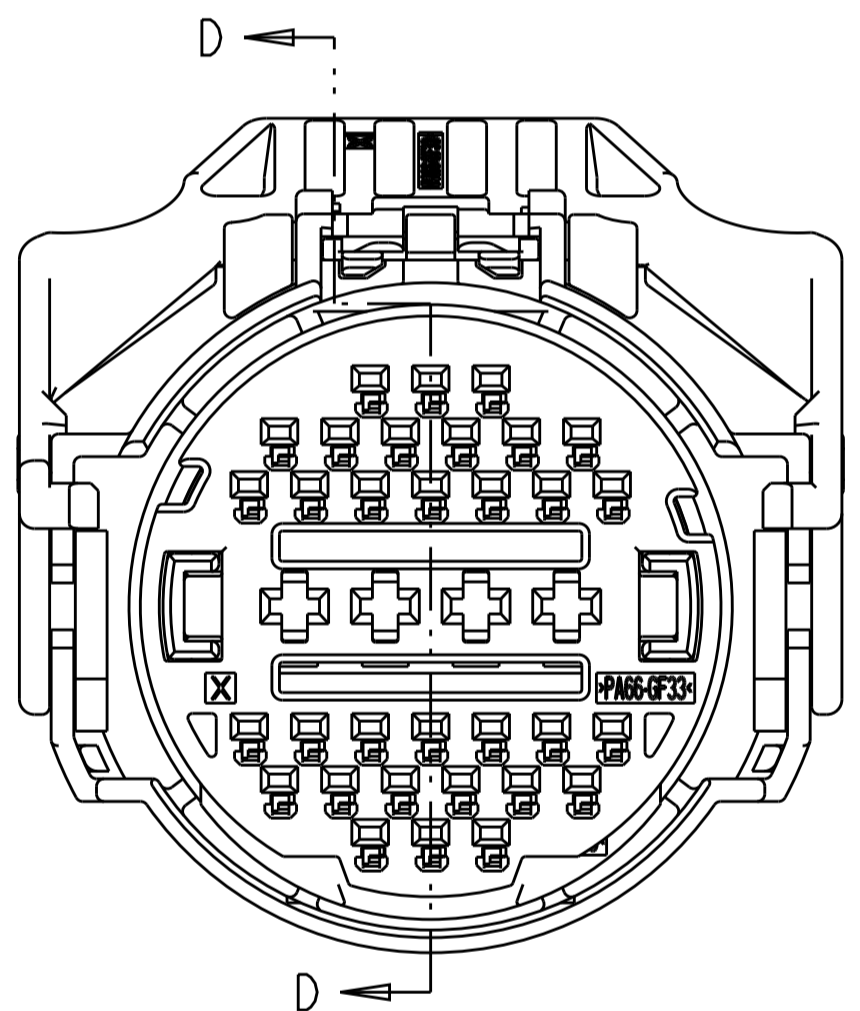

- MATERIAL:
PLUG HOUSING: NYLON 46 30% GLASS FILLED, BLACK.
TERMINAL HOUSING: NYLON 6/6, 33% GLASS FILLED, BLACK
ISL: PBT 15% GLASS FILLED, RED
LEVER: NYLON 6/6, 33% GLASS FILLED, NATURAL
CPA: PBT 15% GLASS FILLED, RED
PERIMETER SEAL: SILICONE
- WIRE DRESS, TE PART # 2138319-1, TO BE PURCHASED SEPERATELY.
- APPLICABLE TERMINALS: SEE TABLE
- LEVER, CPA, & ISL SHOWN IN SHIPPING POSITION, UNLESS OTHERWISE NOTED.
- 2138314-1 KEYING OPTION "A" SHOWN IN GENERAL VIEWS.
- THE CONNECTOR SHOWN MATES WITH THE FOLLOWING TE CAP CONNECTOR. CONSULT FACTORY FOR ADDITIONAL MATING CONNECTOR OPTIONS. 2138338-* (SEE SEPERATE DRAWING FOR APPROPRIATE DASH NUMBER)

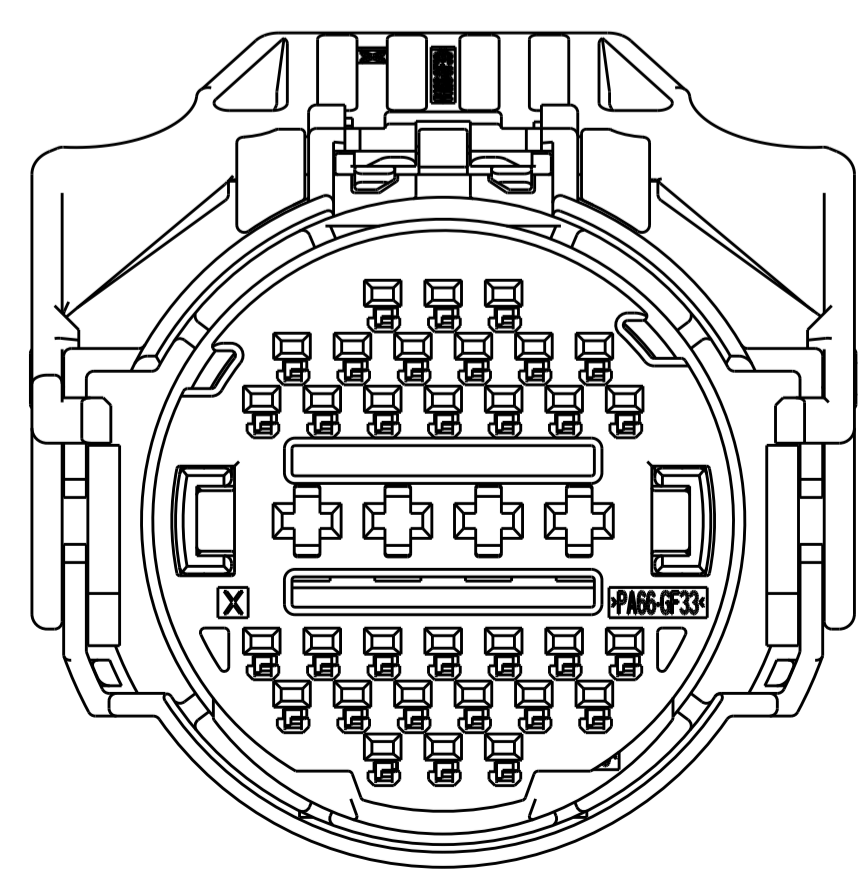
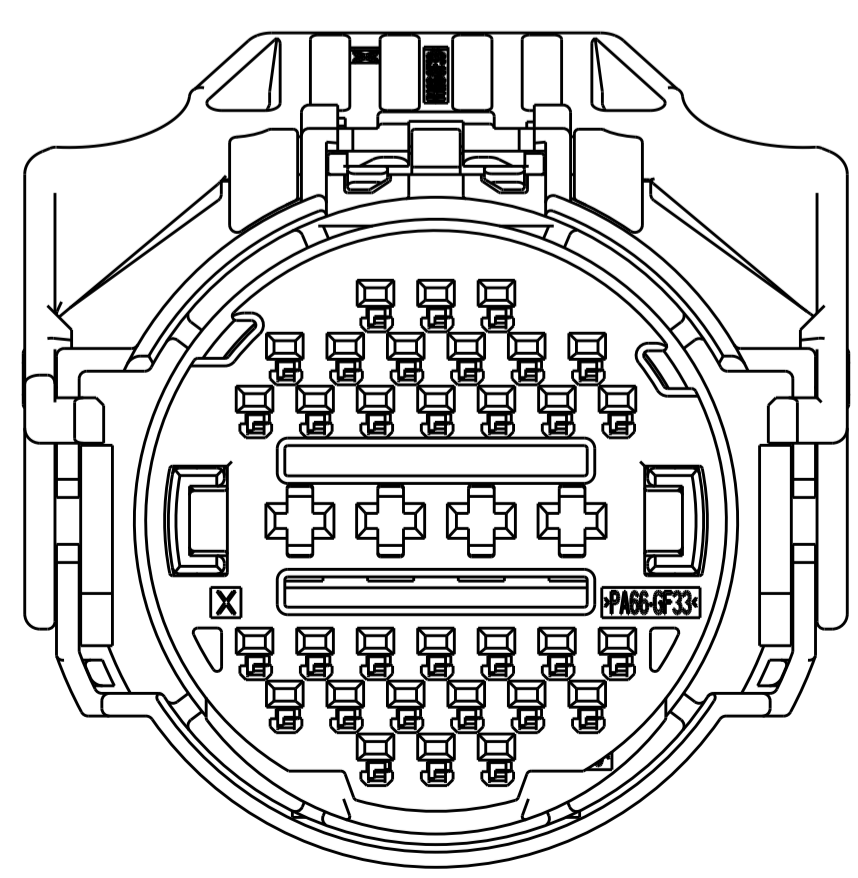
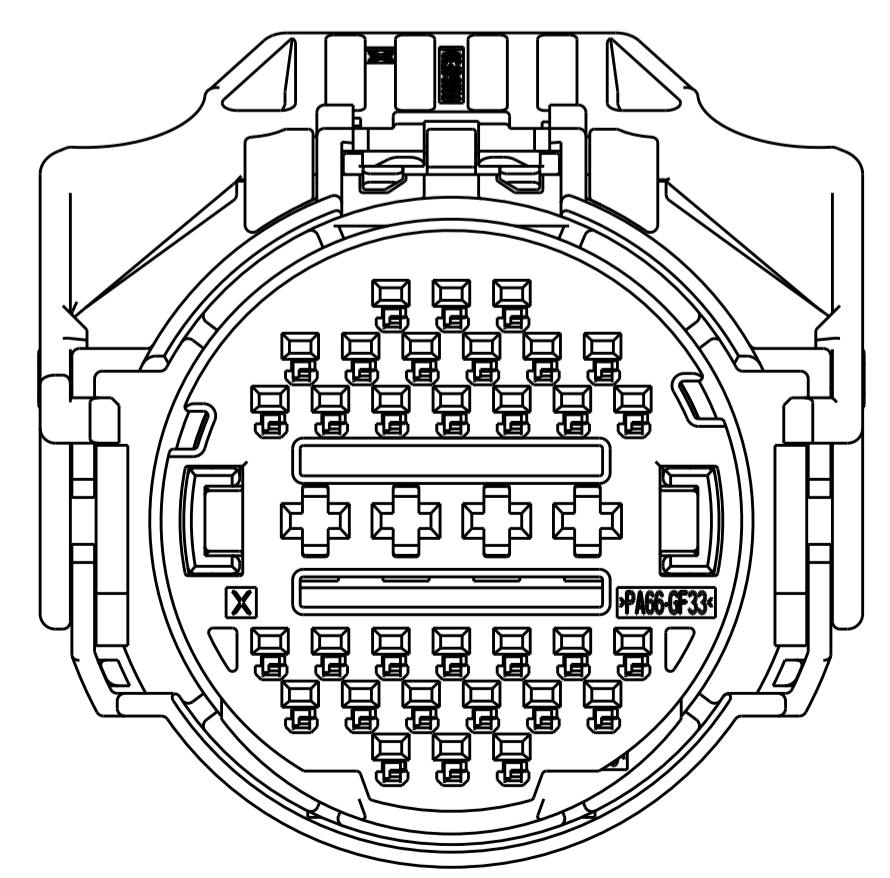
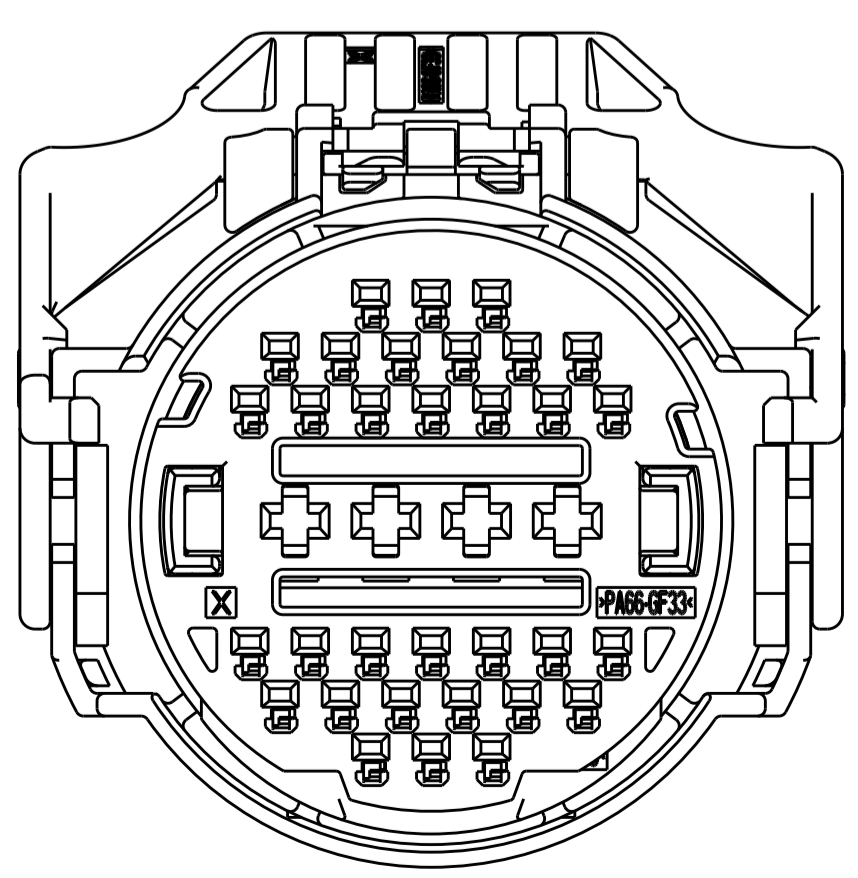

KEY	NUMBER OF OPEN CIRCUITS	36	35	34	33	32	31	30	29	28	27	26	25	24	23	22	21	20	19	18	17	16	15	14	13	12	11	10	9	8	7	6	5	4	3	2	1	ASSEMBLY PART #
A	25																																				1-2138314-1	
A	22	36	35	34	33																																1-2138314-0	
A	28																																				2138314-9	
A	24	36	35	34	33																																2138314-8	
A	29	36																																			2138314-7	
A	32	36																																			2138314-6	
A	27	36																																			2138314-5	
D	36																																				2138314-4	
C	36																																				2138314-3	
B	36																																				2138314-2	
A	36																																				2138314-1	

THIS DRAWING IS A CONTROLLED DOCUMENT.

DMN: HITCHCOCK, TOMAYZOTT
CHK: HETRICK, TOMAYZOTT
APVD: HETRICK, TOMAYZOTT

PRODUCT SPEC: -
APPLICATION SPEC: -

SIZE: - CAGE CODE: - DRAWING NO: A100779C=2138314
SHEET 1 OF 1 REV A1

Customer Drawing