

STRAIGHT BULKHEAD JACK PANEL SEAL
REAR MOUNT CRIMP TYPE - CABLE 2.6/50 S

R143.331.161

Series : TNC-COM

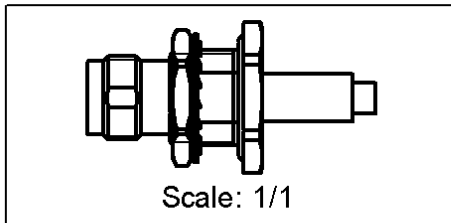
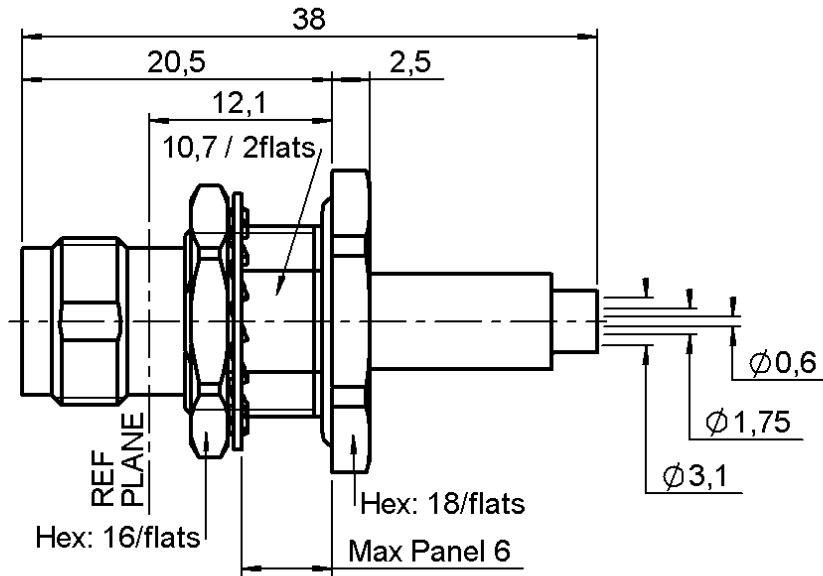

PANEL CUT OUT

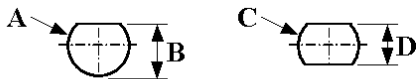

mm			mm		
	Maxi	mini		Maxi	mini
A	12.8	12.7	C	12.8	12.7
B	12.1	12	D	10.9	10.8

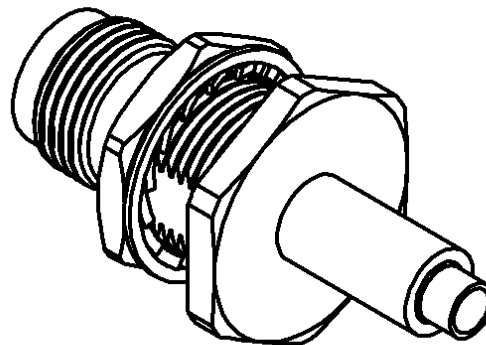

All dimensions are in mm.

COMPONENTS	MATERIALS	PLATING
BODY	BRASS	NICKEL 2 µm
CENTRE CONTACT	BERYLLIUM COPPER	GOLD 0.2 OVER NICKEL 2 µm
OUTER CONTACT	-	- µm
INSULATOR	PTFE	
GASKET	SILICONE RUBBER	
OTHERS PARTS	BRASS	NICKEL 2 µm
-	-	-
-	-	-



Edition : 9845 B

Design changes may be in order to improve the product.

STRAIGHT BULKHEAD JACK PANEL SEAL

R143.331.161

REAR MOUNT CRIMP TYPE - CABLE 2.6/50 S

Series : TNC-COM

ELECTRICAL CHARACTERISTICS

Impedance **50** Ω
 Frequency **0-1.5** GHz
 VSWR **NA + 0.000** x F(GHz) Maxi
 Insertion loss **NA** √F(GHz) dB
 RF leakage - (**NA** - F(GHz)) dB mini
 Operating temperature **-35/+70** °C
 Voltage rating **335** Veff Maxi
 Dielectric withstanding **1000** Veff mini
 Insulation resistance **5000** MΩ mini

SPECIFICATION

Stripping	a	b	c	d	e	f
mm	4.00	10.0	18.5	0.00	14.5	0.00

Assembly instruction : **Crimp 03**

Recommended cables
 RG 316
 RG 188
 KX 22A

Cable retention
 - pull off **40** N mini
 - torque **NA** N.cm

MECHANICAL CHARACTERISTICS

Centre contact retention
 Axial force – Mating end **10** N mini
 Axial force – Opposite end **10** N mini
 Torque **NA** N.cm mini

TOOLING

Part Number	Description	Hexagon
.	.	.
R282.235.011	CRIMPING DIES	1.73-5.41
R282.293.000	CRIMPING TOOL	-
R282.223.000	CRIMPING TOOL	1.73-5.41

Recommended torque
 Mating **NA** N.cm
 Panel nut **370** N.cm
 Clamp nut **NA** N.cm
 A/F clamp nut **0.000** mm

Mating life **100** Cycles mini
 Weight **0.000** g

OTHERS CHARACTERISTICS

-

ENVIRONMENTAL

Hermetic seal **NA** Atm.cm3/s
 Leakage – pressurised only **NA** Mpa



Edition : 9845 B

Design changes may be in order to improve the product.