

MATERIALS

- HOUSING:**
ALUMINUM 6061-T6, NICKEL PLATE
PER SAE-AMS-2404
- INSULATOR:**
LIQUID CRYSTAL POLYMER (LCP)
PER ASTM D5138
- CONTACT:**
COPPER ALLOY PER MIL-DTL-
83513, GOLD PLATED PER ASTM
B488, (HARD GOLD) TYPE II CODE
C CLASS 1.27
- WIRE:**
NEMA HP3 TYPE E, COLOR CODED
IAW MIL-STD-681, SYSTEM 1,
USING TEN SOLID REPEATING
COLORS
- INTERFACIAL SEAL:**
SILICONE RUBBER PER A-A-59588

SOCKET #	COLOR
1, 11, 21, 31	BLACK
2, 12, 22, 32	BROWN
3, 13, 23, 33	RED
4, 14, 24, 34	ORANGE
5, 15, 25, 35	YELLOW
6, 16, 26, 36	GREEN
7, 17, 27, 37	BLUE
8, 18, 28	VIOLET
9, 19, 29	GRAY
10, 20, 30	WHITE

INTERNAL USE ONLY
USE MFG LOADING
PROCEDURE MMDS-037

PART NO.	A99150-037	REV	ECO	DATE	APP
		B	99774	08-12-13	JMJ

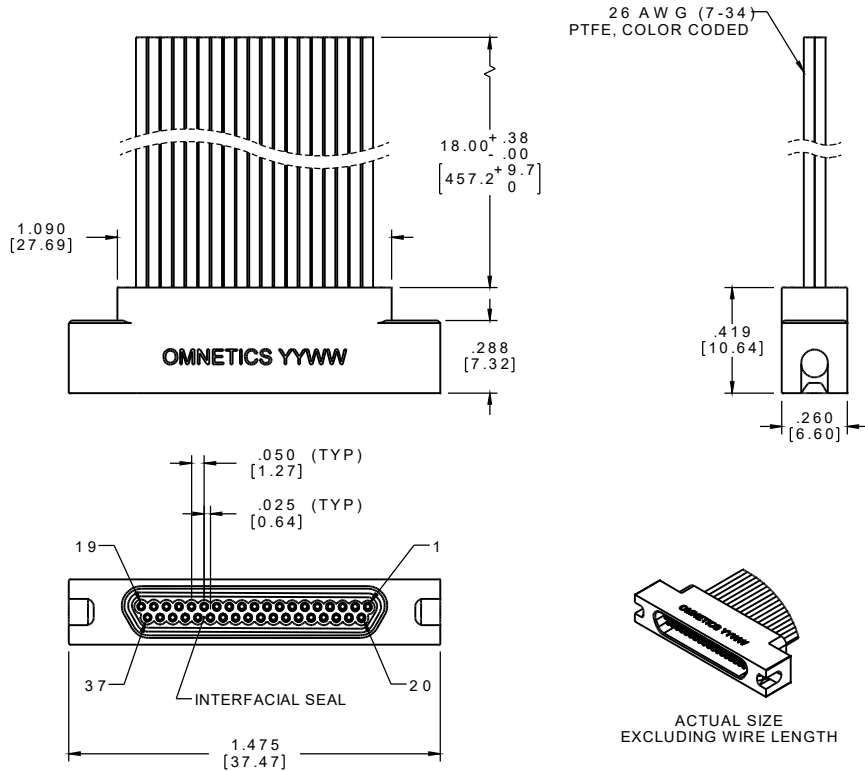

RoHS

NOTE:

DIMENSIONS IN [] ARE IN
MILLIMETERS UNLESS
OTHERWISE NOTED AND ARE
FOR REFERENCE ONLY

THIRD ANGLE -TOLERANCES- UNLESS OTHERWISE NOTED DIMENSIONS IN INCHES 2 P L D E C ± .01 3 P L D E C ± .005 4 P L D E C ± .0005 ANGLE S ± 1°	DFTM. MJM CHK'D. APP'D.	DATE 04-09-12 DATE DATE	TITLE: (37) SOCKET FEMALE MICRO-D CONNECTOR W/LATCHES	THIS DRAWING CONTAINS CONFIDENTIAL AND PROPRIETARY INFORMATION WHICH IS THE PROPERTY OF OMNETICS CONNECTOR CORP. THIS DOCUMENT MAY NOT IN WHOLE OR IN PART BE DUPLICATED, OR DISCLOSED FOR ANY PURPOSE, WITHOUT WRITTEN PERMISSION FROM OMNETICS CONNECTOR CORP.	OMNETICS CONNECTOR CORPORATION 7260 COMMERCE CIRCLE EAST MINNEAPOLIS, MN 55432 WWW.OMNETICS.COM	CAGE CODE 61873 DWG NO. A99150-037 SHEET 1 OF 1 SCALE: 2:1	REV B
---	-------------------------------	----------------------------------	--	--	--	---	----------