

PART NUMBER	REVISION	DESCRIPTION	FEED TYPE
2266110-1	K	FINE CRIMP HEIGHT ADJUST	MECHANICAL
2266110-2	K	FINE CRIMP HEIGHT ADJUST	PNEUMATIC
5-2266110-1	K	SEAL STRIPPER CRIMPER TERMINATING UNIT	MECHANICAL
5-2266110-2	K	SEAL STRIPPER CRIMPER TERMINATING UNIT	PNEUMATIC
7-2266110-1	K	MECHANICAL AND CRIMP TOOLING KIT	MECHANICAL
7-2266110-2	K	PNEUMATIC AND CRIMP TOOLING KIT	PNEUMATIC
7-2266110-7	H	CRIMP TOOLING KIT	-
7-2266110-8	C	APPLICATOR CONVERSION KIT	

ATLANTIC VERSION TERMINATOR INTERFACE ADAPTER

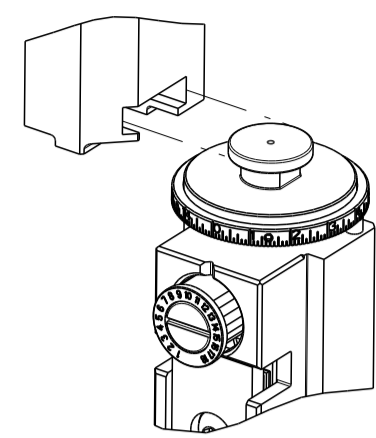

APPLICATOR DATA		
CRIMP	SIZE	TYPE
WIRE	1.88 mm [.074]	F
INSUL	1.73 mm [.068]	O

APPLICATOR INSTRUCTIONS
408-35042

APPLICATOR CONVERSION KITS	
PART NUMBER	INSULATION DIAMETER RANGE
7-2266110-8	Ø1.68-2.39mm [.066-.094]
7-2266111-8	Ø1.27-1.65mm [.050-.065]

TERMINAL DATA: DEUTSCH TERMINAL TE CRIMP SPECIFICATION			
TERMINAL NAME: STAMPED CONTACT PIN SIZE 16			
WIRE STRIP LENGTH	INSULATION DIAMETER RANGE		
3.81-5.09 mm [.150-.200 IN]	Ø1.68-2.39 mm [.066-.094 IN]		
TERMINAL APPLICATION SPECIFICATION	114-151000		
TERMINALS APPLIED			
TE TERMINAL	DEUTSCH TERMINAL	TE TERMINAL	AMPHENOL TERMINAL
286503-4	1060-16-0622	1-286503-6	AT60-16-0622
286503-5	1060-16-0644	1-286503-7	AT60-16-0644
286503-6	1060-16-0688		
1-286503-3	1060-16-0677		

TERMINAL DATA: DEUTSCH TERMINAL TE CRIMP SPECIFICATION			
TERMINAL NAME: STAMPED CONTACT SOCKET SIZE 16			
WIRE STRIP LENGTH	INSULATION DIAMETER RANGE		
3.81-5.09 mm [.150-.200 IN]	Ø1.68-2.39 mm [.066-.094 IN]		
TERMINAL APPLICATION SPECIFICATION	114-151000		
TERMINALS APPLIED			
TE TERMINAL	DEUTSCH TERMINAL	TE TERMINAL	DEUTSCH TERMINAL
286504-4	1062-16-0622	286504-5	1062-16-0644
1-286504-4	1062-16-0677	286504-6	1062-16-0688

WIRE SIZE	CRIMP HEIGHT mm [INCH]	CRIMP HEIGHT REFERENCE SETTING
16 AWG	1.27+0.03/-0.05 [.050+.001/-0.002]	6.5
1.00mm2	1.27+0.03/-0.05 [.050+.001/-0.002]	6.5
18 AWG	1.24+0.03/-0.05 [.049+.001/-0.002]	6.8
0.75mm2	1.22+0.03/-0.05 [.048+.001/-0.002]	6.9
20 AWG	1.22+0.03/-0.05 [.048+.001/-0.002]	6.9
0.50mm2	1.14+0.03/-0.05 [.045+.001/-0.002]	7.7

- 1 RECOMMENDED SPARE PARTS
- 2 REFER TO SUPPLIED INSTRUCTION SHEET FOR CLEANING, LUBRICATION AND STORAGE OF APPLICATOR.
- 3 APPLY PART NUMBER 1-23419-5 LOCTITE TO THREADS OF ITEM 180. APPLY PART NUMBER 2-23419-6 LOCTITE TO THREADS OF ITEM 242.
- 4 CRIMP HEIGHT REFERENCE SETTING WAS THE SETTING USED WHEN THE APPLICATOR WAS QUALIFIED AT THE FACTORY. ADJUSTMENT MAY BE NECESSARY WHEN RUNNING APPLICATOR IN THE FIELD.
- 5 TERMINAL LUBRICANT IS RECOMMENDED.
- 6 UNLESS SPECIFIED OTHERWISE TORQUE VALUES SHALL BE USED PER DOCUMENT, 101-35000.
- 7 SEE APPROPRIATE APPLICATOR LOG SHEETS FOR APPLIED TERMINALS AND WIRE RANGE.
- 8 DIMENSION 3.1±0.50 APPLIES TO PIN TERMINALS 1060-16-06XX
- 9 DIMENSION 7.60±0.50 APPLIES TO SOCKET TERMINALS 1062-16-06XX

*WARNING
ON INSTALLATION, SET WIRE DISC TO CRIMP HEIGHT REFERENCE SETTING FOR LARGEST WIRE SIZE. CRIMP HEIGHT REFERENCE SETTINGS GREATER THAN THE VALUE SHOWN MAY CAUSE DAMAGE TO THE CRIMP TOOLING. REFER TO THE INSTRUCTION SHEET FOR PROPER SETUP AND ADJUSTMENTS.

LOC	DIST	REVISIONS					
A	66	P	LTN	DESCRIPTION	DATE	DWN	APVD
		H		ECR-19-017064	04NOV2019	FZ	RK
		J		ECR-20-015383	28OCT2020	JWC	RK
		J1		ECR-21-003343	18MAR2021	FZ	RK
		K		ECR-22-151720	06SEP2022	ROY	GEB

-	-	-	-	1	1	-	-	1803515-3	RAM ASSEMBLY, SF ATLANTIC	293
-	-	-	-	1	1	-	-	2-1803583-1	APPLICATOR BASIC ASSEMBLY, SF	292
-	-	1	-	1	-	1	-	2119641-1	FEED CAM, AIR FEED	248
-	-	1	1	1	1	1	1	2119082-9	CAM, SNAIL, INSULATION ADJUSTMENT	244
-	-	1	1	1	1	1	1	2079764-1	WASHER, WAVE SPRING, CREST-TO-CREST	243
-	-	1	1	1	1	1	1	2119083-1	RETAINER, INSULATION DIAL	242
-	-	1	1	1	1	1	1	7-18023-7	SCR, SKT HD CAP M3 X 4.0	241
-	-	-	1	-	1	-	1	2119580-1	MECHANICAL FEED ASSEMBLY	239
-	-	1	-	1	-	1	-	2844940-1	AIR FEED MODULE	238
-	-	-	-	1	1	-	-	4-1722335-3	STRIPPER, SIDE FEED	182
-	-	-	-	1	1	-	-	1-5018030-0	NUT, HEX, REG, RoHS, M3.5	181
-	-	-	-	1	1	-	-	2-1752354-0	STANDOFF, HOLD-DOWN	180
-	-	-	-	1	1	-	-	993111-1	PIN, SLOTTED SPRING 3.0 X 20.0	177
-	-	-	-	1	1	-	-	5-22280-0	SPRING, COMPRESSION	176
-	-	-	-	1	1	-	-	1752353-3	GUIDE PIN, HOLDDOWN	175
-	-	-	-	1	1	-	-	1901680-2	GUIDE PIN, HOLDDOWN	174
-	-	REF	REF	REF	REF	REF	REF	994970-2	COUNTER, MAGNETIC	164
-	-	1	1	1	1	1	1	2119955-1	ASSY, LUBRICATOR, SIDE FEED	113
-	-	1	1	1	1	1	1	2844908-1	SCREW, LOCKING	99
-	-	1	1	1	1	1	1	2844907-1	POST, LOCKING	98
-	-	1	1	1	1	1	1	455888-4	SPACER, CRIMPER	82
1	-	-	-	-	-	-	-	2266110	PRINT, APPLICATOR LOG SHEET	72
-	-	1	1	1	1	1	1	1803607-3	DOCUMENTATION PACKAGE	71
-	-	2	2	2	2	2	2	2119791-5	DEPRESSOR, WIRE	70
-	-	1	1	1	1	1	1	2119740-1	TAG, IDENTIFICATION	67
-	-	2	2	2	2	2	2	2168078-1	SCREW, DRIVE, RH, RoHS, 2 x .188	66
-	-	1	1	1	1	1	1	2168083-2	SCR, SKT HD CAP, RoHS, M4 X 8.0	60
-	-	1	1	1	1	1	1	5-18022-5	SCR, HEX HD CAP, M4 X 6.0	59
-	-	1	1	1	1	1	1	1338685-1	PAWL, FEED	56
-	-	4	4	4	4	4	4	2168083-3	SCR, SKT HD CAP, RoHS, M4 X 12.0	54
-	-	2	2	2	2	2	2	2168083-3	SCR, SKT HD CAP, RoHS, M4 X 12.0	53
-	-	1	1	1	1	1	1	1803382-6	HOLD DOWN, SPRING LOADED	50
-	-	1	2	1	2	1	2	18023-9	SCR, SKT HD CAP M4 X 6.0	49
-	-	-	1	-	1	-	1	2119652-1	FEED CAM, PRE FEED	48
-	-	-	1	-	1	-	1	2119653-1	FEED CAM, POST FEED	47
-	-	1	1	-	-	1	1	1803583-9	APPLICATOR BASIC ASSEMBLY, SF	46
-	-	1	1	-	-	1	1	1803515-1	RAM ASSEMBLY, SF ATLANTIC	44
-	-	1	1	1	1	1	1	1803602-1	SCR, BHSC, RoHS (M8 X 25)	41
-	-	1	1	1	1	1	1	2-1752356-0	SUPPORT, TERMINAL	34
-	-	2	2	2	2	2	2	2079383-5	SCR, BHSC, RoHS (M4 X 20)	33
-	-	2	2	2	2	2	2	2-2844962-6	SPACER, CYLINDRICAL, STRIP GUIDE	30
-	-	1	1	1	1	1	1	2844992-1	ASSEMBLY, STRIP GUIDE	29
-	-	1	1	1	1	1	1	1320928-2	STRIP GUIDE	24
-	-	1	1	-	-	1	1	2168083-2	SCR, SKT HD CAP, RoHS, M4 X 8.0	21
-	-	2	2	1	1	2	2	1-18028-2	WASHER, FLAT, REG M4	20
-	-	1	1	-	-	1	1	2119533-1	STRIPPER, SIDE FEED	19
-	-	1	1	1	1	1	1	2119806-1	INSERT, SHEAR	13
-	-	1	1	1	1	1	1	3-22280-3	SPRING, COMPRESSION	12
-	-	1	1	1	1	1	1	1-356885-4	STOP, SHEAR	11
-	-	1	1	1	1	1	1	2119805-1	SHEAR HOLDER, FRONT	10
-	-	1	1	1	1	1	1	1803095-6	FLOATING SHEAR, FRONT	9
1	1	2	2	1	1	1	1	1803293-6	ANVIL, COMBINATION DEUTSCH STYLE	8
-	-	1	1	1	1	1	1	6-240641-7	SPACER	7
-	-	-	-	-	-	-	-	-	-	6
-	-	1	1	1	1	1	1	1-2119757-0	DEPRESSOR, SHEAR	5
-	-	1	1	1	1	1	1	238011-9	BLOCK, CRIMPER SPACER	4
1	1	2	2	1	1	1	1	1803019-7	CRIMPER, INSULATION O	3
1	-	1	1	1	1	1	1	455888-5	SPACER, CRIMPER	2
1	-	1	2	2	1	1	1	4-1633713-1	CRIMPER, WIRE PREMIUM	1

ATLANTIC VERSION
Shown on sheets 1 of 4 & 2 of 4
(Pacific version shown on sheets 3 of 4 & 4 of 4)

DIMENSIONS:		TOLERANCES UNLESS OTHERWISE SPECIFIED:		DRAWING NO		REVISIONS	
mm	PLC	mm	PLC	DATE	BY	DATE	BY
	0 PLC ±		0 PLC ±	08-Oct-13	R. KNEPPER	08-Oct-13	
	1 PLC ±		1 PLC ±		G. BAILEY		
	2 PLC ±		2 PLC ±		M. CLIFFORD	08-Oct-13	
	3 PLC ±		3 PLC ±				
	4 PLC ±		4 PLC ±				
	ANGLES ±		ANGLES ±				
	FINISH		FINISH				

NAME	Ocean Side Feed Applicator		
SIZE	CAGE CODE	DRAWING NO	RESTRICTED TO
A1	00779	2266110	
Customer Accessible Production Drawing		SCALE	SHEET 1 of 4
		1:2	REV K

LOC	DIST	REVISIONS					
A	66	P	LYN	DESCRIPTION	DATE	OWN	APVD
		-		SEE SHEET 1			

FEED TYPE MECHANICAL

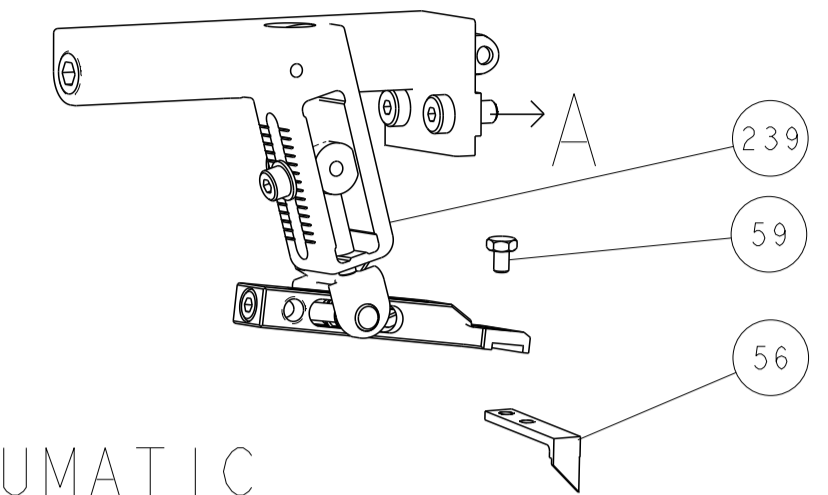

PNEUMATIC

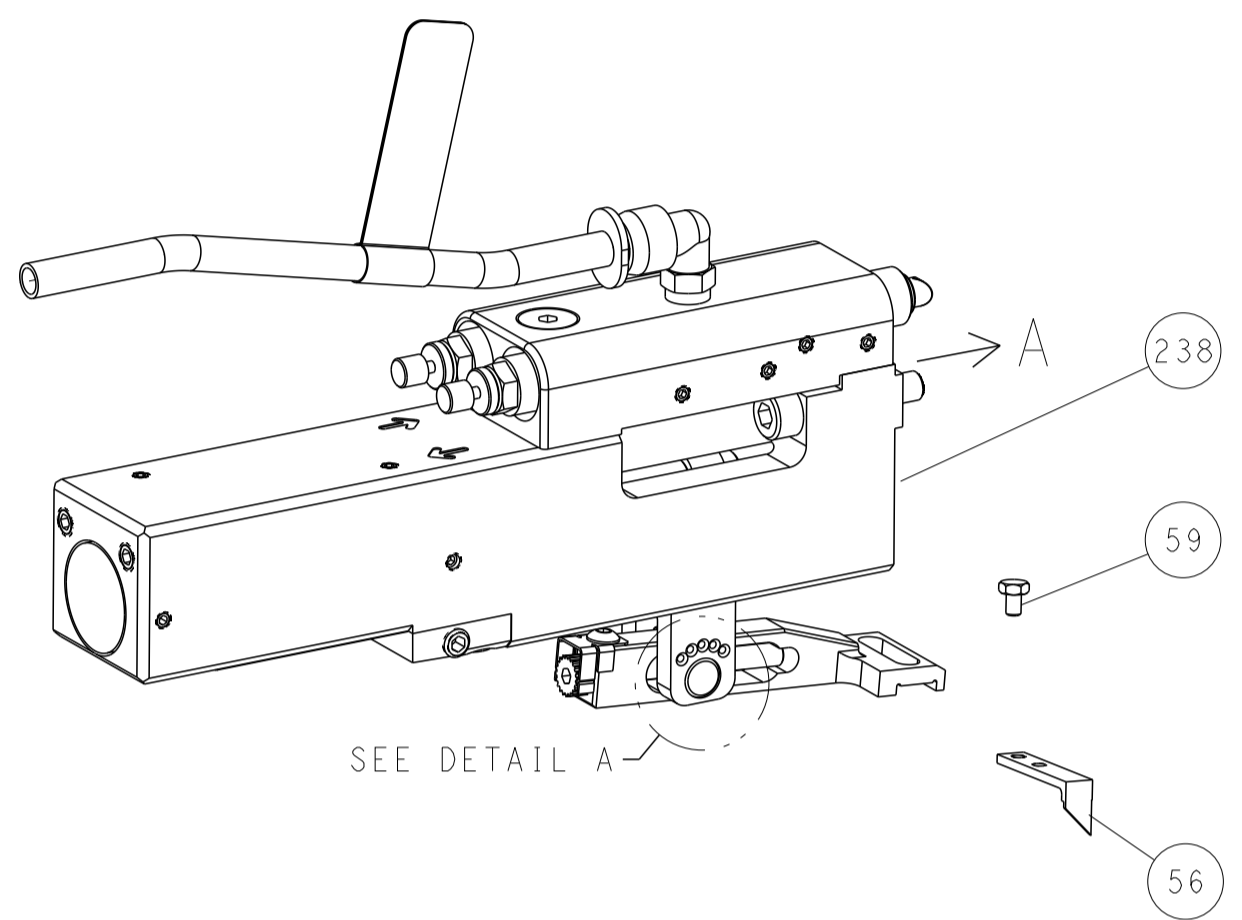

FEED SPRING SETTING POSITION (SHOWN FROM REAR SIDE)



DETAIL A

CAM POSITIONS

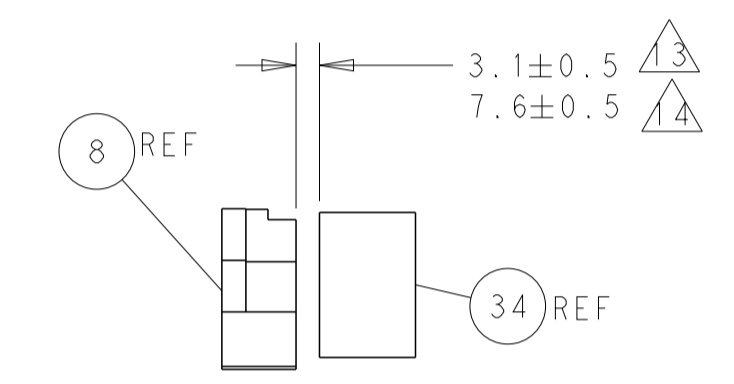
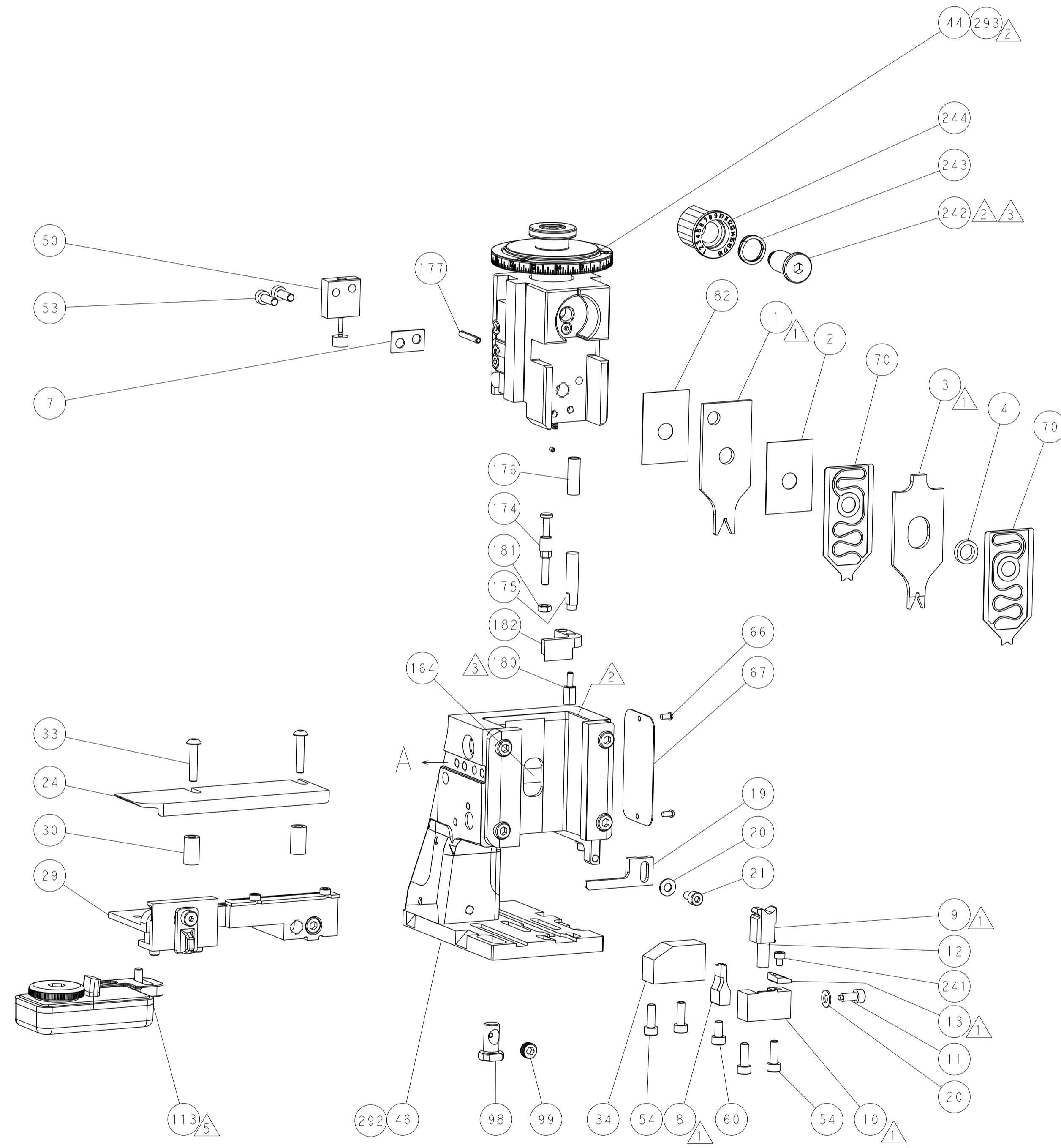
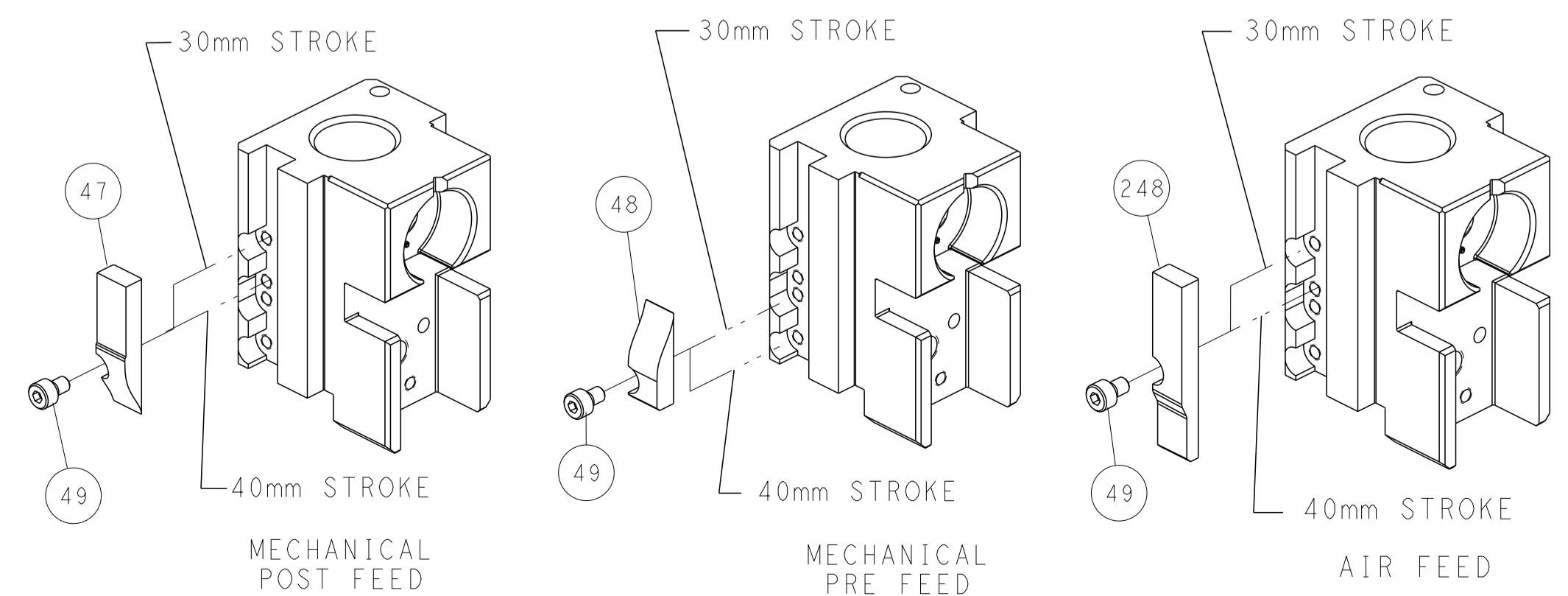

TERMINAL SUPPORT LOCATION

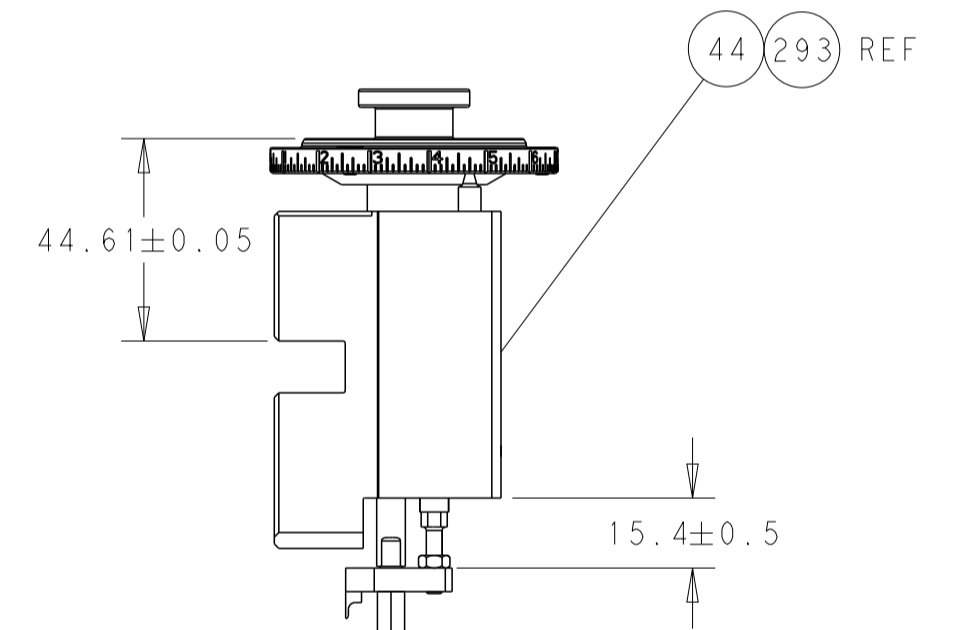

RAM SET-UP

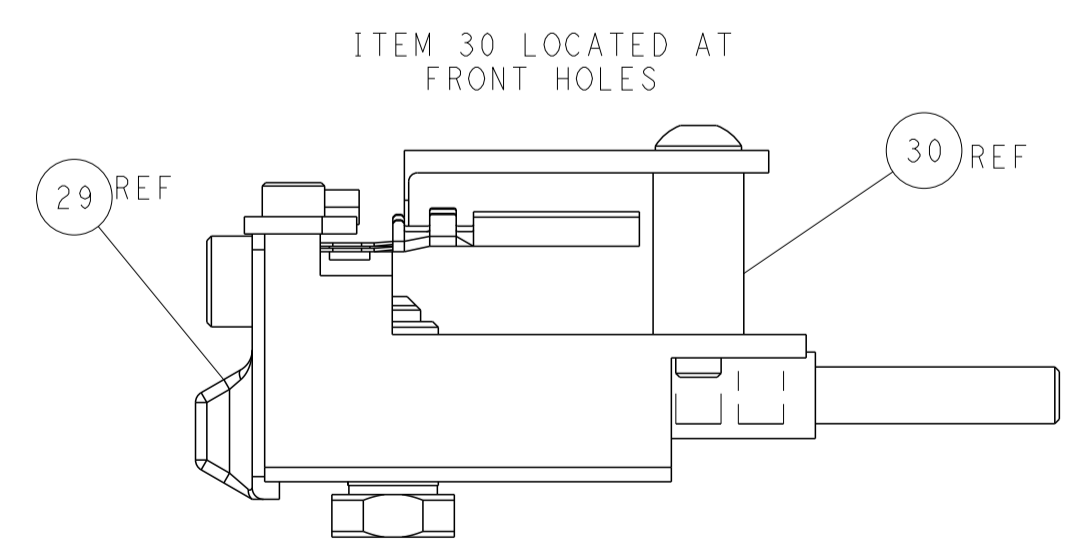

FEED TRACK POSITION GUIDE BY INSULATION BARREL

ATLANTIC VERSION
 Shown on sheets 1 of 4 & 2 of 4
 (Pacific version shown on sheets 3 of 4 & 4 of 4)

DIMENSIONS: mm 		TOLERANCES UNLESS OTHERWISE SPECIFIED: 0 PLC ± 1 PLC ± 2 PLC ± 3 PLC ± 4 PLC ± ANGLES ± FINISH ±		DWN R. KNEPPER 08-Oct-13 CHK G. BAILEY 08-Oct-13 APVD M. CLIFFORD 08-Oct-13 PRODUCT SPEC APPLICATION SPEC WEIGHT SCALE 1:2		NAME Ocean Side Feed Applicator SIZE CAGE CODE DRAWING NO. A1 00779 ©=2266110 SHEET 2 OF 4 REV K	
MATERIAL:				RESTRICTED TO:			

PART NUMBER	REVISION	DESCRIPTION	FEED TYPE
2-2266110-1	K	FINE CRIMP HEIGHT ADJUST	MECHANICAL
2-2266110-2	K	FINE CRIMP HEIGHT ADJUST	PNEUMATIC
7-2266110-7	H	CRIMP TOOLING KIT	-
7-2266110-8	C	APPLICATOR CONVERSION KIT	-

PACIFIC VERSION TERMINATOR
INTERFACE ADAPTER



APPLICATOR DATA		
CRIMP	SIZE	TYPE
WIRE	1.88 mm [.074]	F
INSUL	1.73 mm [.068]	O

APPLICATOR INSTRUCTIONS
408-35042

APPLICATOR CONVERSION KITS	
PART NUMBER	INSULATION DIAMETER RANGE
7-2266110-8	Ø1.68-2.39mm [.066-.094]
7-2266111-8	Ø1.27-1.65mm [.050-.065]

TERMINAL DATA: DEUTSCH TERMINAL TE CRIMP SPECIFICATION			
TERMINAL NAME: STAMPED CONTACT CONTACT PIN SIZE 16			
WIRE STRIP LENGTH	INSULATION DIAMETER RANGE		
3.81-5.09 mm [.150-.200 IN]	Ø1.68-2.39 mm [.066-.094 IN]		
TERMINAL APPLICATION SPECIFICATION	114-151000	-	-
TERMINALS APPLIED			
TE TERMINAL	DEUTSCH TERMINAL	TE TERMINAL	AMPHENOL TERMINAL
286503-4	1060-16-0622	1-286503-6	AT60-16-0622
286503-5	1060-16-0644	1-286503-7	AT60-16-0644
286503-6	1060-16-0688		
1-286503-3	1060-16-0677		

TERMINAL DATA: DEUTSCH TERMINAL TE CRIMP SPECIFICATION			
TERMINAL NAME: STAMPED CONTACT SOCKET SIZE 16			
WIRE STRIP LENGTH	INSULATION DIAMETER RANGE		
3.81-5.09 mm [.150-.200 IN]	Ø1.68-2.39 mm [.066-.094 IN]		
TERMINAL APPLICATION SPECIFICATION	114-151000	-	-
TERMINALS APPLIED			
TE TERMINAL	DEUTSCH TERMINAL	TE TERMINAL	DEUTSCH TERMINAL
286504-4	1062-16-0622	286504-5	1062-16-0644
1-286504-4	1062-16-0677	286504-6	1062-16-0688

WIRE SIZE	CRIMP HEIGHT mm [INCH]	CRIMP HEIGHT REFERENCE SETTING
16 AWG	1.27+0.03/-0.05 [.050+.001/- .002]	6.5
1.00mm ²	1.27+0.03/-0.05 [.050+.001/- .002]	6.5
18 AWG	1.24+0.03/-0.05 [.049+.001/- .002]	6.8
0.75mm ²	1.22+0.03/-0.05 [.048+.001/- .002]	6.9
20 AWG	1.22+0.03/-0.05 [.048+.001/- .002]	6.9
0.50mm ²	1.14+0.03/-0.05 [.045+.001/- .002]	7.7

- RECOMMENDED SPARE PARTS
- REFER TO SUPPLIED INSTRUCTION SHEET FOR CLEANING, LUBRICATION AND STORAGE OF APPLICATOR.
- APPLY PART NUMBER 2-23419-6 LOCTITE TO THREADS OF ITEM 242.
- CRIMP HEIGHT REFERENCE SETTING WAS THE SETTING USED WHEN THE APPLICATOR WAS QUALIFIED AT THE FACTORY. ADJUSTMENT MAY BE NECESSARY WHEN RUNNING APPLICATOR IN THE FIELD.
- TERMINAL LUBRICANT IS RECOMMENDED.
- UNLESS SPECIFIED OTHERWISE TORQUE VALUES SHALL BE USED PER DOCUMENT, 101-35000.
- SEE APPROPRIATE APPLICATOR LOG SHEETS FOR APPLIED TERMINALS AND WIRE RANGE.
- DIMENSION 3.1±0.50 APPLIES TO PIN TERMINALS 1060-16-06XX
- DIMENSION 7.60±0.50 APPLIES TO SOCKET TERMINALS 1062-16-06XX

***WARNING**
ON INSTALLATION, SET WIRE DISC TO CRIMP HEIGHT REFERENCE SETTING FOR LARGEST WIRE SIZE. CRIMP HEIGHT REFERENCE SETTINGS GREATER THAN THE VALUE SHOWN MAY CAUSE DAMAGE TO THE CRIMP TOOLING. REFER TO THE INSTRUCTION SHEET FOR PROPER SETUP AND ADJUSTMENTS.

PACIFIC VERSION
Shown on sheets 3 of 4 & 4 of 4
(Atlantic version shown on sheets 1 of 4 & 2 of 4)

LOC	DIST	REVISIONS					
A	66	P	LTN	DESCRIPTION	DATE	DWN	APVD
-	-	-	-	SEE SHEET 1	-	-	-

-	-	1	1	2119082-9	CAM, SNAIL, INSULATION ADJUSTMENT	244
-	-	1	1	2079764-1	WASHER, WAVE SPRING, CREST-TO-CREST	243
-	-	1	1	2119083-1	RETAINER, INSULATION DIAL	242
-	-	1	1	7-18023-7	SCR, SKT HD CAP M3 X 4.0	241
-	-	-	1	2119580-1	MECHANICAL FEED ASSEMBLY	239
-	-	1	-	2844940-1	AIR FEED MODULE	238
-	-	REF	REF	994970-2	COUNTER, MAGNETIC	164
-	-	1	-	2119641-2	FEED CAM, AIR FEED	151
-	-	1	1	2168083-8	SCR, SKT HD CAP, RoHS, M4 X 16	144
-	-	4	4	2168083-9	SCR, SKT HD CAP, RoHS, M4 X 20	143
-	-	-	1	2119653-2	FEED CAM, POST FEED	142
-	-	1	1	1-1803583-0	APPLICATOR BASIC ASSEMBLY, SF	141
-	-	1	1	1803516-1	RAM ASSEMBLY, SF PACIFIC	140
-	-	1	1	2119955-1	ASSY, LUBRICATOR, SIDE FEED	113
-	-	1	1	2844908-1	SCREW, LOCKING	99
-	-	1	1	2844907-1	POST, LOCKING	98
-	-	1	1	455888-4	SPACER, CRIMPER	82
1	-	-	-	2266110	PRINT, APPLICATOR LOG SHEET	72
-	-	1	1	1803607-3	DOCUMENTATION PACKAGE	71
-	-	2	2	2119791-5	DEPRESSOR, WIRE	70
-	-	1	1	2119740-1	TAG, IDENTIFICATION	67
-	-	2	2	2168078-1	SCREW, DRIVE, RH, RoHS, 2 x .188	66
-	-	1	1	5-18022-5	SCR, HEX HD CAP, M4 X 6.0	59
-	-	1	1	1338685-1	PAWL, FEED	56
-	-	2	2	2168083-3	SCR, SKT HD CAP, RoHS, M4 X 12.0	53
-	-	1	1	1803382-6	HOLD DOWN, SPRING LOADED	50
-	-	1	2	18023-9	SCR, SKT HD CAP M4 X 6.0	49
-	-	-	1	2119652-1	FEED CAM, PRE FEED	48
-	-	1	1	1803602-1	SCR, BHSC, RoHS (M8 X 25)	41
-	-	1	1	2-1752356-0	SUPPORT, TERMINAL	34
-	-	2	2	2079383-5	SCR, BHSC, RoHS (M4 X 20)	33
-	-	2	2	2-2844962-6	SPACER, CYLINDRICAL, STRIP GUIDE	30
-	-	1	1	2844992-1	ASSEMBLY, STRIP GUIDE	29
-	-	1	1	1320928-2	STRIP GUIDE	24
-	-	1	1	2168083-2	SCR, SKT HD CAP, RoHS, M4 X 8.0	21
-	-	2	2	1-18028-2	WASHER, FLAT, REG M4	20
-	-	1	1	2119533-1	STRIPPER, SIDE FEED	19
-	-	1	1	2119806-1	INSERT, SHEAR	13
-	-	1	1	3-22280-3	SPRING, COMPRESSION	12
-	-	1	1	1-356885-4	STOP, SHEAR	11
-	-	1	1	2119805-1	SHEAR HOLDER, FRONT	10
-	-	1	1	1803095-6	FLOATING SHEAR, FRONT	9
1	1	1	1	1803293-6	ANVIL, COMBINATION DEUTSCH STYLE	8
-	-	1	1	6-240641-7	SPACER	7
-	-	-	-	-	-	6
-	-	1	1	1-2119757-0	DEPRESSOR, SHEAR	5
-	-	1	1	238011-9	BLOCK, CRIMPER SPACER	4
1	1	1	1	1803019-7	CRIMPER, INSULATION O	3
1	-	1	1	455888-5	SPACER, CRIMPER	2
1	-	1	1	4-1633713-1	CRIMPER, WIRE PREMIUM	1

DIMENSIONS:		TOLERANCES UNLESS OTHERWISE SPECIFIED:		MATERIAL:		FINISH:		WEIGHT:		SCALE:		SHEET:		REV:				
mm	0 PLC ±	1 PLC ±	2 PLC ±	3 PLC ±	4 PLC ±	ANGLES	FINISH			Customer Accessible Production Drawing	SCALE	1:2	SHEET	3	OF	4	REV	K



TE Connectivity
Harrisburg, PA 17105-3608

Ocean Side Feed
Applicator

SIZE: A1 CAGE CODE: 00779 DRAWING NO: C=2266110

LOC	DIST	REVISIONS					
A	66	P	LTM	DESCRIPTION	DATE	OWN	APVD
		-	-	SEE SHEET 1	-	-	-

FEED TYPE MECHANICAL

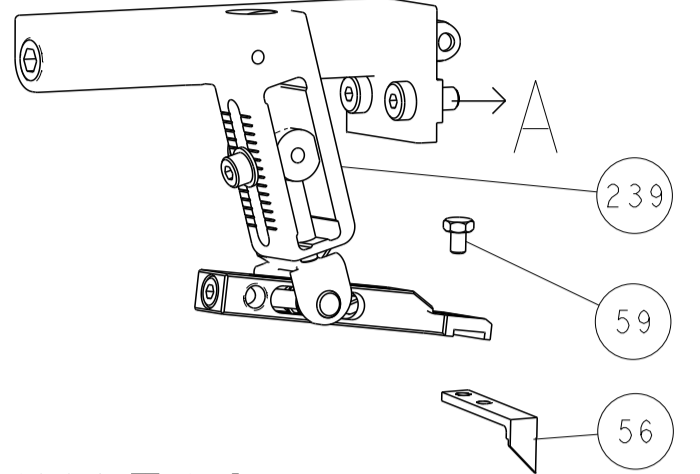

PNEUMATIC

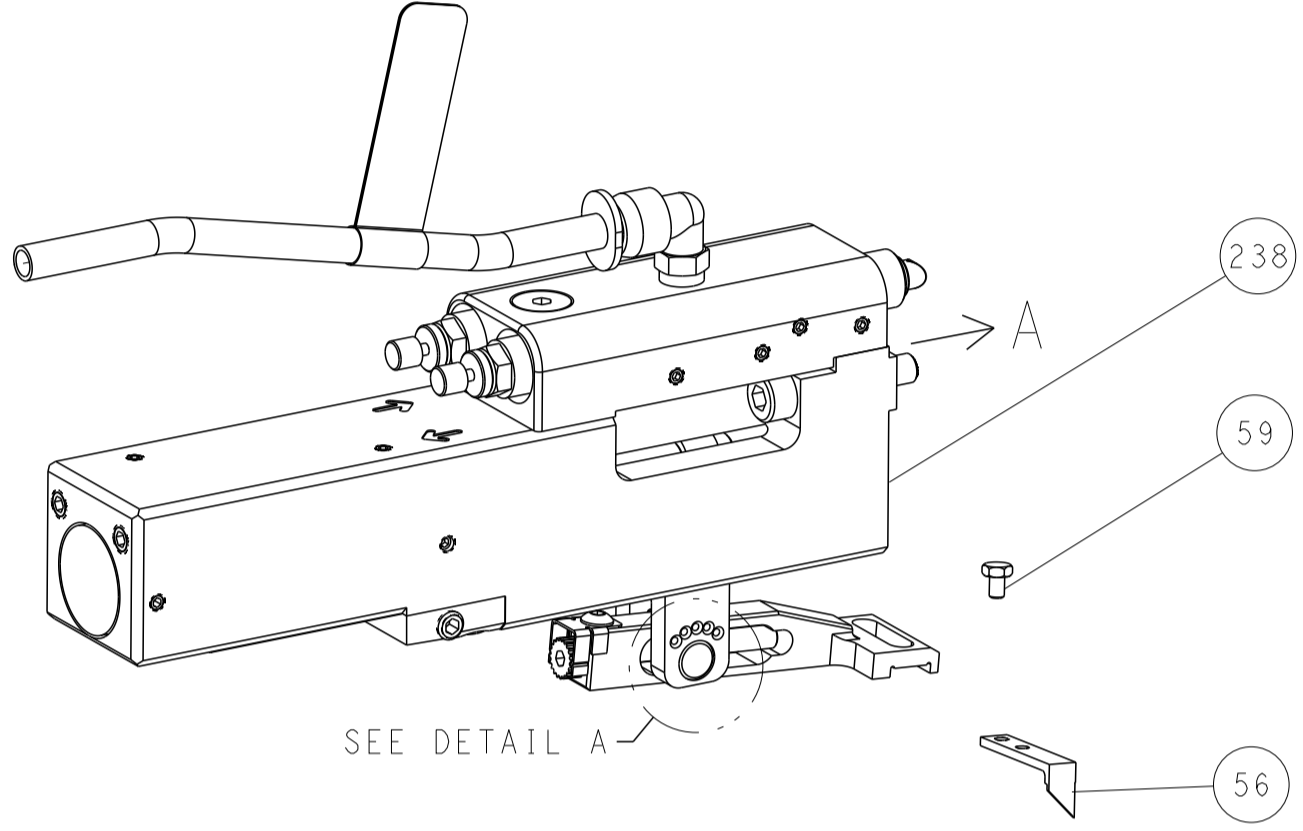

FEED SPRING SETTING POSITION (SHOWN FROM REAR SIDE)

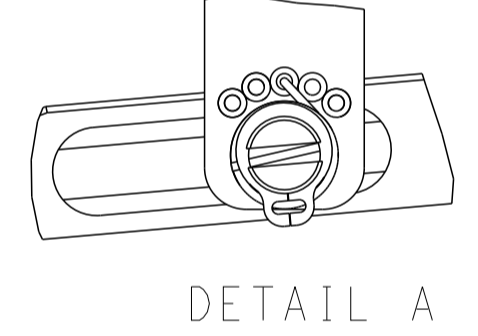

CAM POSITIONS

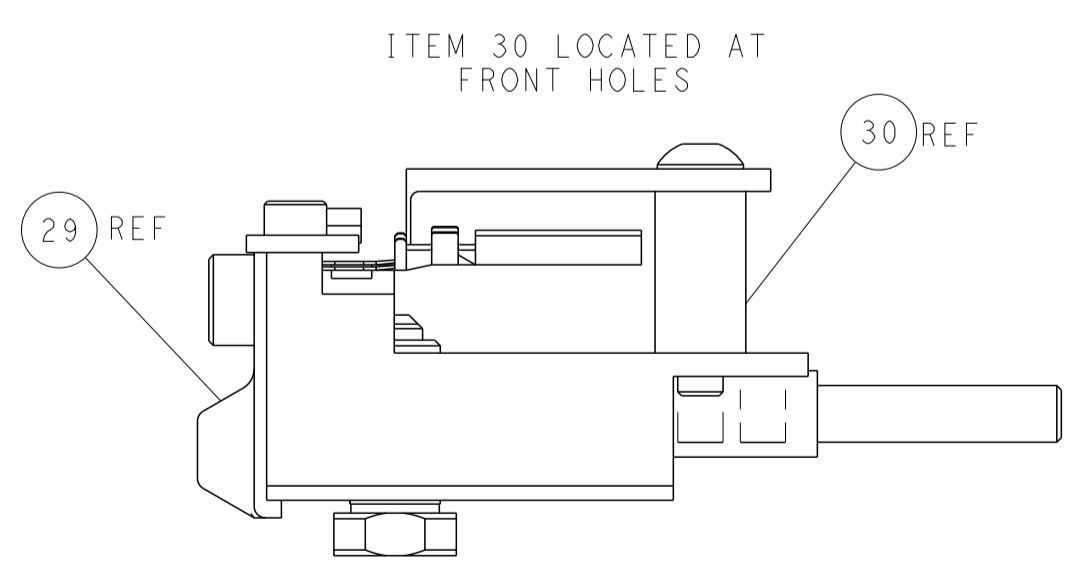
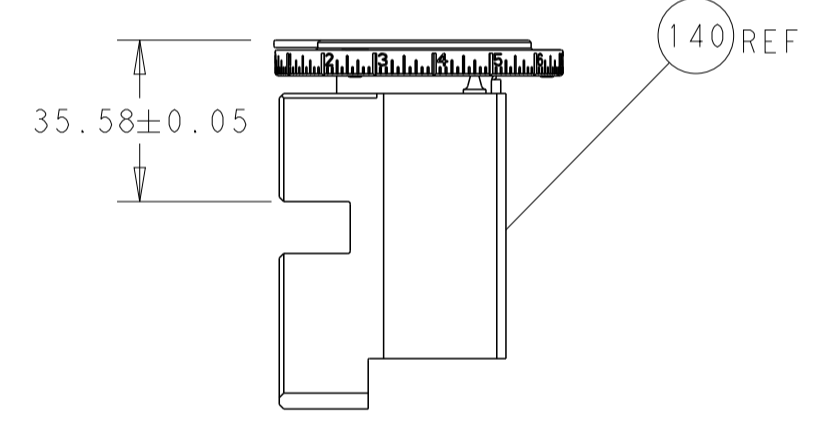
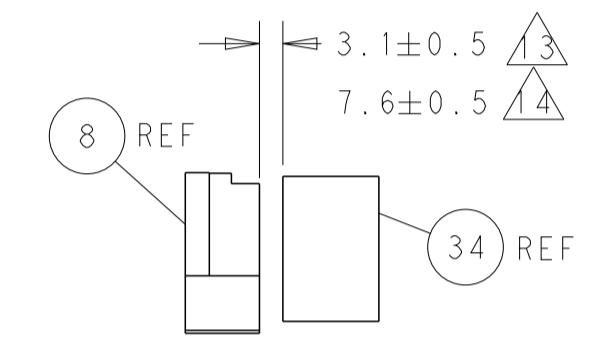
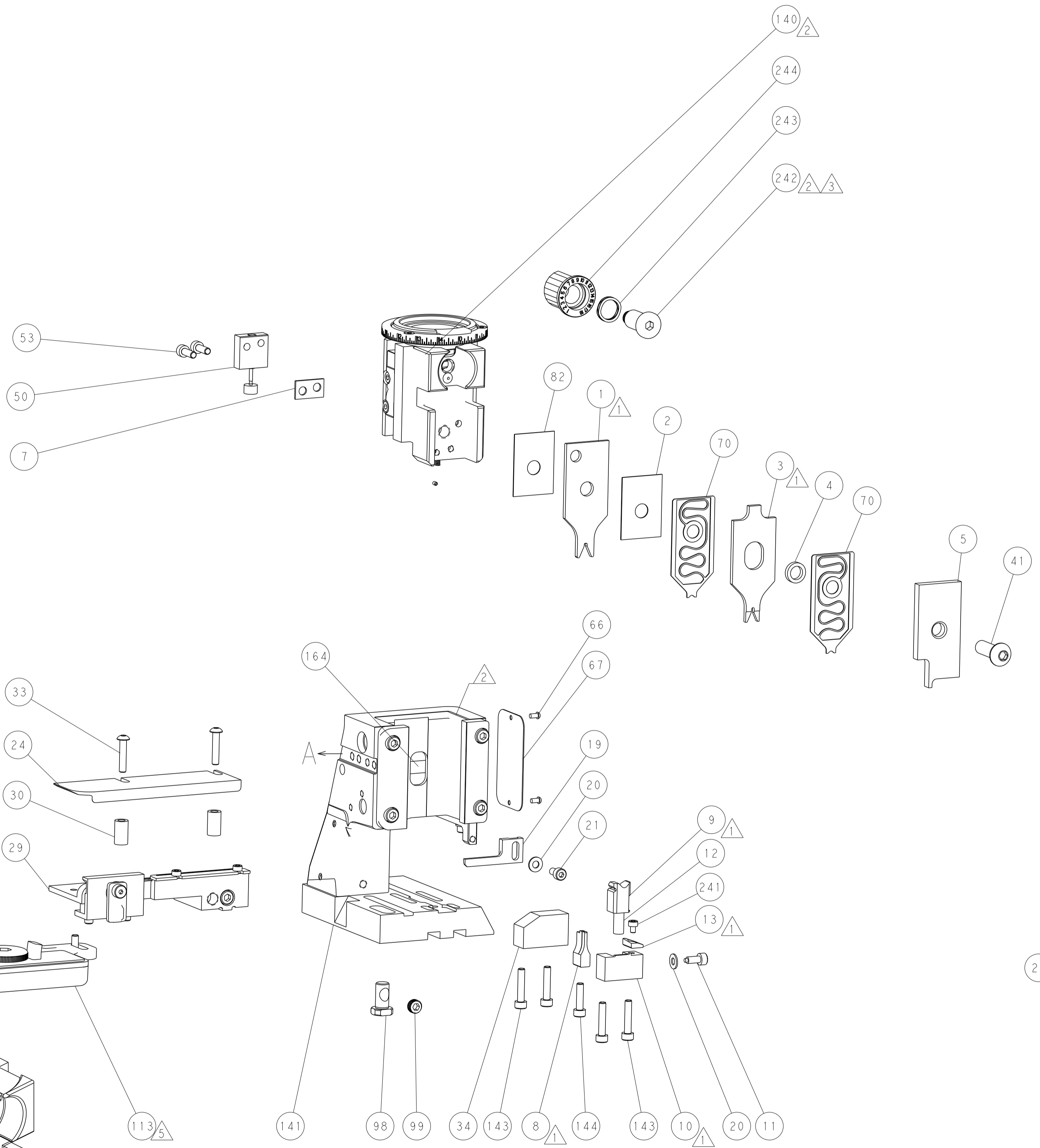
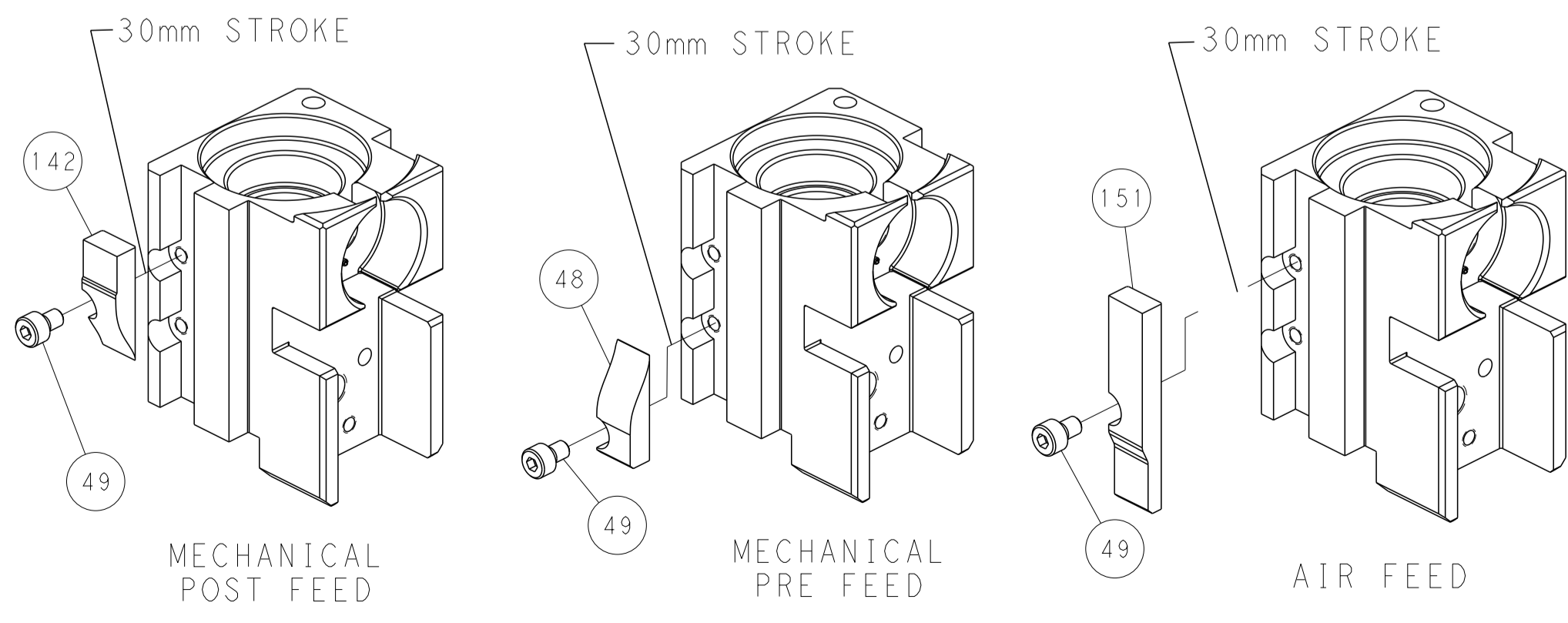

PACIFIC VERSION
 Shown on sheets 3 of 4 & 4 of 4
 (Atlantic version shown on sheets 1 of 4 & 2 of 4)

<small>THIS DRAWING IS UNPUBLISHED. RELEASED FOR PUBLICATION. ALL RIGHTS RESERVED. THIS DRAWING IS THE PROPERTY OF TYCO ELECTRONICS CORPORATION. IT IS TO BE USED ONLY FOR THE PURPOSES SPECIFIED AND IS NOT TO BE REPRODUCED OR TRANSMITTED IN ANY FORM OR BY ANY MEANS, ELECTRONIC OR MECHANICAL, INCLUDING PHOTOCOPYING, RECORDING, OR BY ANY INFORMATION STORAGE AND RETRIEVAL SYSTEM, WITHOUT THE WRITTEN PERMISSION OF TYCO ELECTRONICS CORPORATION.</small>		DWN R. KNEPPER 08-Oct-13 CHK G. BAILEY 08-Oct-13 APVD M. CLIFFORD 08-Oct-13	NAME Ocean Side Feed Applicator
DIMENSIONS: mm 	TOLERANCES UNLESS OTHERWISE SPECIFIED: 0 PLC ± 1 PLC ± 2 PLC ± 3 PLC ± 4 PLC ± ANGLES ± FINISH	PRODUCT SPEC APPLICATION SPEC WEIGHT SCALE 1:2	SIZE A1 CAGE CODE 00779 DRAWING NO C=2266110 SHEET 4 OF 4 REV K