

# S1C17554/564

## 16-bit Single Chip Microcontroller

- 48-pin wafer-chip-scale package (WCSP)
- 10-bit A/D converter
- Code-efficient architecture optimized for the C language, single-cycle instruction high processing performance, serial ICE, and built-in 16-bit RISC PCU core S1C17

### ■ DESCRIPTIONS

The S1C17554/564 is a compact 16-bit MCU that delivers high-speed, low power operation with large address space and on-chip ICE. It integrates A/D converter and thus various analog-interface sensors are connectable. The ultra small power-saving 48-pin WCSP is most suitable for sensor-applied products that require low power consumption and high-speed processing.

### ■ FEATURES

The main features of the S1C17554/564 are listed below.

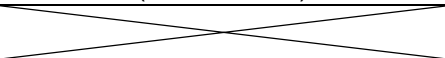
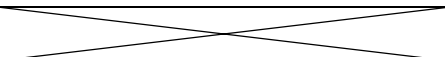
Model	S1C17554	S1C17564
<b>CPU</b>		
CPU core	Seiko Epson original 16-bit RISC CPU core S1C17	
Multiplier/Divider (COPRO)	<ul style="list-style-type: none"><li>• 16-bit × 16-bit multiplier</li><li>• 16-bit × 16-bit + 32-bit multiply and accumulation unit</li><li>• 16-bit ÷ 16-bit divider</li></ul>	
<b>Embedded Flash memory</b>		
Capacity	128K bytes (for both instructions and data)	
Erase/program count	Min. 1 time	
Other	<ul style="list-style-type: none"><li>• Read/program protection function</li><li>• An erasing/programming power supply (VPP) is required.</li><li>• Allows on-board programming using a debugging tool such as ICDmini.</li></ul>	
<b>Embedded RAM</b>		
Capacity	16K bytes	
<b>Clock generator</b>		
System clock source	2 sources (OSC3/OSC1)	3 sources (IOSC/OSC3/OSC1)
IOSC oscillator circuit		2/4/8/12 MHz(typ.) internal oscillator circuit
OSC3 oscillator circuit	24 MHz (max.) crystal or ceramic oscillator circuit Supports an external clock input.	
OSC1 oscillator circuit	32.768 kHz (typ.) crystal oscillator circuit Supports an external clock input.	
Other	<ul style="list-style-type: none"><li>• Core clock frequency control</li><li>• Peripheral module clock supply control</li></ul>	
<b>I/O ports</b>		
Number of general-purpose I/O ports	Max. 40 bits (TQFP13-64pin package) Max. 34 bits (WCSP-48 package) (Pins are shared with the peripheral I/O.)	Max. 40 bits (Pins are shared with the peripheral I/O.)
<b>Serial interfaces</b>		
SPI	3 channels	
I <sup>2</sup> C master (I2CM)	1 channel	
I <sup>2</sup> C slave (I2CS)	1 channel	
UART	2 channels (IrDA1.0 supported)	
IR remote controller (REMC)	1 channel	
Universal serial interface (USI)		2 channels (Usable as a UART, SPI, or I <sup>2</sup> C)
<b>Timers</b>		
16-bit timer (T16)	3 channels	
Fine mode 16-bit timer (T16F)	2 channels	
16-bit PWM timer (T16A)	4 channels	
Clock timer (CT)	1 channel	
Stopwatch timer (SWT)	1 channel	

# S1C17554/564

Watchdog timer (WDT)	1 channel	
<b>A/D converter</b>		
Conversion method	Successive approximation type	
Number of analog input channels	4 channels (max.)	
Resolution	10 bits	
<b>Interrupts</b>		
Reset interrupt	#RESET pin	
NMI	Watchdog timer	
Programmable interrupts	23 systems (8 levels)	
<b>Power supply voltage</b>		
Core voltage (LVDD)	1.65 V to 1.95 V	1.65 V to 1.95 V (Not required when the regulator is used.)
I/O voltage (HVDD)	1.65 V to 5.5 V	2.0 V to 5.5 V (Regulator used) 1.65 V to 5.5 V (Regulator not used)
Analog voltage (AVDD)	2.7 V to 5.5 V	
Flash programming voltage (VPP)	7 V/7.5V	
<b>Regulator</b>		
Input voltage		2.0 V to 5.5 V
Output voltage		1.8 V
Other		Enables the system to operate with a 3.3 V or 5.0 V single power supply.
<b>Operating temperature</b>		
Operating temperature range	-40° C to 85° C	
<b>Current consumption (Typ value, LVDD = HVDD = 1.8 V)</b>		
SLEEP state	0.8 μA (OSC1 = Off, OSC3 = Off)	1.2 μA (OSC1 = Off, IOSC = Off, OSC3 = Off)
HALT state	2.7 μA (OSC1 = 32 kHz, OSC3 = Off)	3.1 μA (OSC1 = 32 kHz, IOSC = Off, OSC3 = Off)
Run state	16 μA (OSC1 = 32 kHz, OSC3 = Off)	16 μA (OSC1 = 32 kHz, IOSC = Off, OSC3 = Off)
	3000 μA (OSC1 = Off, OSC3 = 8 MHz ceramic)	3000 μA (OSC1 = Off, IOSC = Off, OSC3 = 8 MHz ceramic)
		4500 μA (OSC1 = Off, IOSC = 12 MHz, OSC3 = Off)
A/D conversion	380 μA (AVDD = 3.6 V, 100 kHz sampling, FSEL[1:0] = 0x0, XPD[1:0] = 0x3)	
<b>Shipping form</b>		
1	TQFP13-64pin (10 mm × 10 mm × 1.0 mm, lead pitch: 0.5 mm)	
2	Die form (3.137 mm × 3.137 mm, pad pitch: 140 μm)	
3	WCSP-48 (3.137 mm × 3.137 mm × 0.72 mm, ball pitch: 0.4 mm)	

# S1C17554/564

## ■ BLOCK DIAGRAM

S1C17554

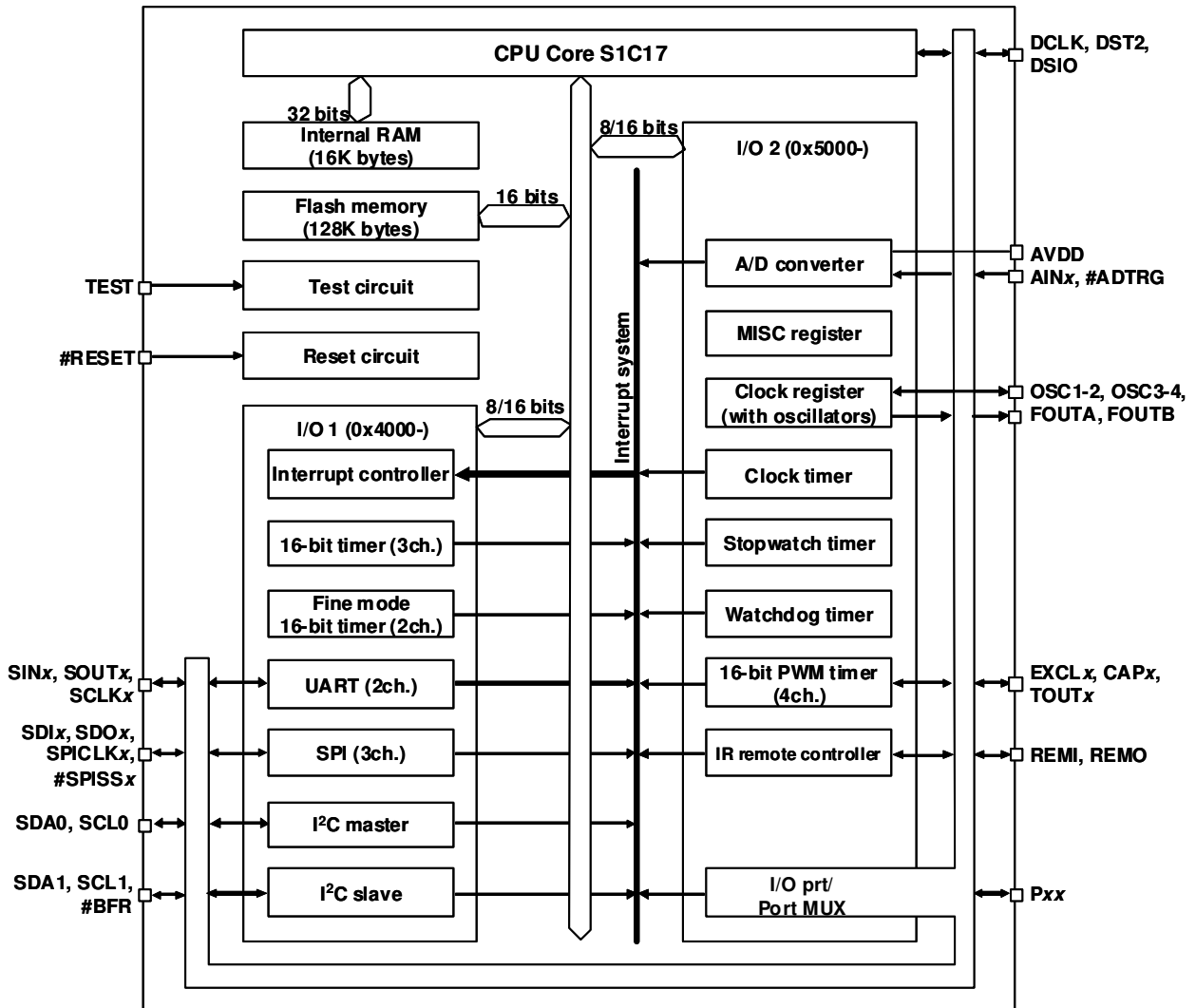

# S1C17554/564

S1C17564

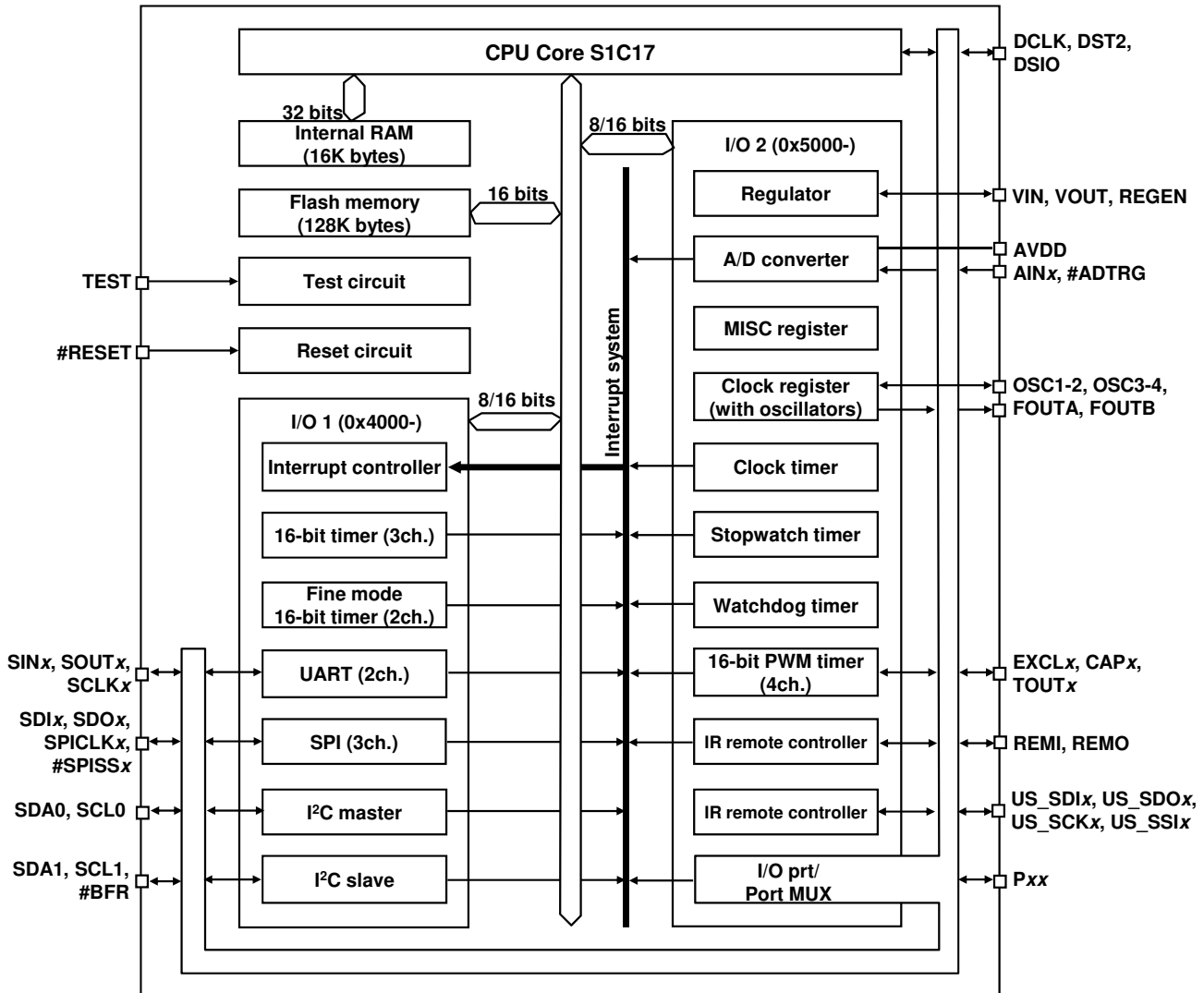

**NOTICE:**

No part of this material may be reproduced or duplicated in any form or by any means without the written permission of Seiko Epson. Seiko Epson reserves the right to make changes to this material without notice. Seiko Epson does not assume any liability of any kind arising out of any inaccuracies contained in this material or due to its application or use in any product or circuit and, further, there is no representation that this material is applicable to products requiring high level reliability, such as, medical products. Moreover, no license to any intellectual property rights is granted by implication or otherwise, and there is no representation or warranty that anything made in accordance with this material will be free from any patent or copyright infringement of a third party. When exporting the products or technology described in this material, you should comply with the applicable export control laws and regulations and follow the procedures required by such laws and regulations. You are requested not to use, to resell, to export and/or to otherwise dispose of the products (and any technical information furnished, if any) for the development and/or manufacture of weapon of mass destruction or for other military purposes.

All brands or product names mentioned herein are trademarks and/or registered trademarks of their respective companies.

©Seiko Epson Corporation 2013 All rights reserved

**SEIKO EPSON CORPORATION**

EPSON semiconductor website

**MICRODEVICES OPERATIONS DIVISION**

[http://www.epson.jp/device/semicon\\_e/](http://www.epson.jp/device/semicon_e/)

**IC Sales & Marketing Department**  
 421-8 Hino, Hino-shi, Tokyo 191-8501, JAPAN  
 Phone: +81-42-587-5814 FAX: +81-42-587-5117

Document code: 411827101  
 First issue April, 2010  
 Revised Aug, 2013.