

# JABAR<sup>®</sup>

SOLUTIONS in SHIELDING



# MIL SPEC EMI Shielding Products

- Silicone Rubber (Molded/Extruded)
- Silicone Sponge (Molded/Extruded)
- QPL: MIL-DTL-83528
- Aerospace, FDA, Automotive and Commercial Grades
- In-house Testing Laboratory
- Specialty Elastomers
- Custom Compounding
- Applications Engineering
- RTV Silicone Rubber

Nolato's high performance Mil Spec EMI shielding and thermal interface products provide integrity and quality for performance-critical aerospace and telecommunication applications.

These shielding products are manufactured to M83528 standards of the Defense Logistics Agency as well as a variety of commercial standards to cover a broad spectrum of shielding needs across multiple markets. We maintain ISO 9001 certification.



<b>Series 100</b> Optical Filtering Devices ..... 4	<b>Series 800</b> Conductive Particle Filled Elastomers.....16 Performance Characteristics.....17 Sheets.....18 Extrusions.....19 Wave Guides ..... 22 Connector Gaskets..... 24
<b>Series 200</b> Air Filtration Devices ..... 5	<b>Series 000</b> Conductive Adhesives ..... 28
<b>Series 300</b> Knitted Wire Mesh Materials ..... 7	<b>Series 900</b> Expanded Metal/Cloth Elastomer ..... 29
<b>Series 301</b> Monel Mesh Tape ..... 9	<b>Specialty Shielding—Conductive Seals</b> Reinforced, Mold-in-Place and Co-Molded ..... 30
<b>Series 400</b> Wire Mesh and Elastomer Combinations .....10	
<b>Series 500</b> Wire Mesh Over Elastomer .....12	
<b>Series 600</b> Wire Oriented in Silicone.....14	



Series 100

# Optical Filtering Devices

**DESCRIPTION**

These optical filtering devices are produced by incorporating a layer of woven mesh into a sheet of clear acrylic and machined to fit your specifications. They can be manufactured from .060 in. thick to .300 in. thick with sizes ranging from .25 in. to 24 in. in width and length. Variations can be produced to your required needs.

**APPLICATION**

Optical filtering devices are used in applications where the viewing port has to be optically clear and also shield against unwanted EMI/RFI interference. The incorporated mesh can provide the needed attenuation, while the gasket and method of termination can provide the desired electrical bond. Gaskets should inhibit moisture and supply conductivity throughout the window. Wire mesh bonded to (SERIES 400) or oriented in (SERIES 600)—either sponge or solid silicone—can supply this termination. Other typical interfaces include gaskets to customer requirements.

When choosing a conductive media it is important to consider both shielding performance capabilities and optical characteristics. In most instances, enhanced performance will lessen the light transmissions, which will result in slightly less visibility. We recommend that our customers discuss their application needs with our engineers to insure the optimum overall performance.

**OPTICAL FILTERING DEVICES INCLUDE:**

- EMI/RFI Shielding
- Anti-glare coating
- Anti-reflective coating
- Anti-fog filters
- Protective screens
- Contrast enhancement filters
- Optical bonding to touchscreens
- Optical heaters
- Night vision imaging systems filters

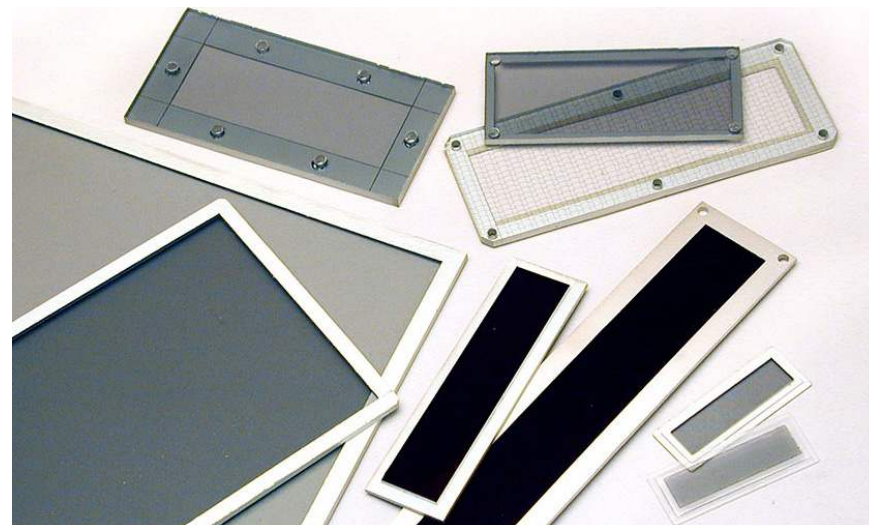

**AVAILABLE COMBINATIONS**

Available Materials	Available Mesh	Available Window Coating	Available Gasket Choice
Acrylic	Printed Copper	Hard Coat	Wire Mesh (Series 400)
Polycarbonate	Blackened Copper Wire	Anti-glare	Wire Oriented in Silicone (Series 600)
	Stainless Steel	Anti-reflection	
	Plated and Blackened Stainless Steel Wire	Anti-fog	Particle Filled Elastomer (Series 800)

Series 200

# Air Filtration Devices

**DESCRIPTION**

Ventilation panels are specifically designed to maintain a substantial airflow while filtering unwanted EMI and/or dust. These air filtration devices are available in a wide variety of styles to meet specific needs.

**APPLICATION**

Intended for use where electronic equipment requires ventilation, while the free flow of electromagnetic waves is not acceptable. The filtration media chosen for your application depends on your specific requirements. Listed below are the various types available.

**Honeycomb Core:** This type of media is used most frequently in the electronics industry. This allows for the best airflow of all the available filtration media. The effective attenuation depends on the core material chosen, the depth and width of the cell, and the plating used.

**Woven Screen:** This style of media is used when dust and EMI must be controlled. Corrugated screen is layered to the required thickness—usually one half inch—and is supplied with a water-soluble film to aid in dust retention.

**Expanded Metal:** Layers of expanded metal screen are compiled to produce our most effective dust/EMI filtration device. This media generates the most resistance to the airflow, however its efficient retention of dust is unsurpassed.

A variety of thicknesses (and cell widths) are available for each of the filtration media.

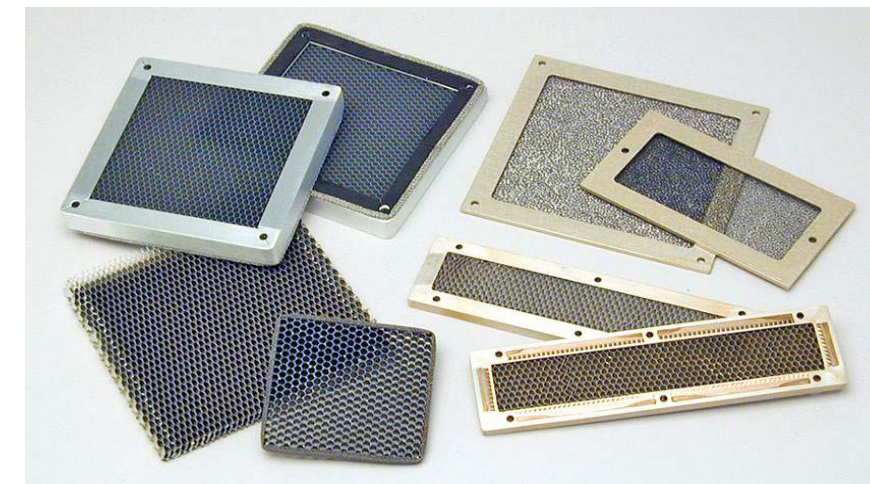

**FILTRATION COMBINATIONS AVAILABLE**

FILTER MEDIA	Thickness	Cell Width
Honeycomb Aluminum	.250	.062
Honeycomb Brass	.375	.062
Honeycomb Steel	.375	.125
Woven Aluminum Screen	.500	.062
Expanded Aluminum Screen	.500	.125
	.750	.125
	.750	.188
	1.00	.125
	1.00	.188

FASTENER DESIGN
Thru Holes
Rivnuts
Helicoil
No Holes

GASKET CHOICE
Neoprene Sponge
Neoprene Solid
Silicone Sponge
Silicone Solid
Wire Oriented in Silicone
Wire Mesh Gasket
Conductive Particle Silicone Gasket

  

FINISH
Chromate Conversion Film
Tin Plating
Cadmium Plating
Electroless Nickel Plating

**SHIELDING EFFECTIVENESS**  
The shielding effectiveness of a vent panel will vary depending on its construction. Thickness, cell size, metal make-up, plating, fastener location and the interface gasket all play an important role in the final effectiveness of the installed panel. The following table shows the variation of specific designs using the same style of gasket interface (SnCuFe wire mesh) in 12 in. x 12 in. vents.

PLATING	100 KHz	10MHz	100 MHz	1GHz	10GHz
Chromate	65	110	110	80	65
Tin	85	130	130	110	90
Tin	120	130	130	120	120
Tin	120	125	130	120	120
Chromate	85	110	110	85	65
Tin	90	120	120	110	90
Tin	100	130	130	110	110

STANDARD VENT DESIGN

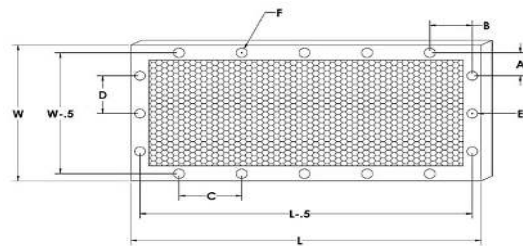

FASTENER DESIGN

The type of fastener, as well as the spacing between the fasteners, is an important design consideration. This decision must incorporate the compressibility of the gasket, the thickness (flexibility) of the mating surfaces and the intended closing force.

PLATING CAPABILITIES

- Black Oxide Coating
- Chemical Film
- Chrome
- Copper
- Electroless Nickel
- Nickel (QQ-N-290)
- Passivate
- Sulfuric Anodize
- Hard Anodized
- Tin

FRAME DESIGN

Aluminum vent panels require extruded frames for structural support. Figures 2.1 thru 2.5 show the cross-section view of our extruded framing materials.

Fig. 2.1: 0.375 base X 0.250 leg

Fig. 2.2: 0.500 base X 0.250 leg

Fig. 2.3: 0.625 base X 0.500 leg

Fig. 2.4: 1.125 base X 0.500 leg

Fig. 2.5: 1.060 base X 0.375 leg

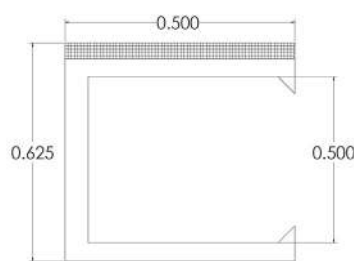

Fig. 2.1

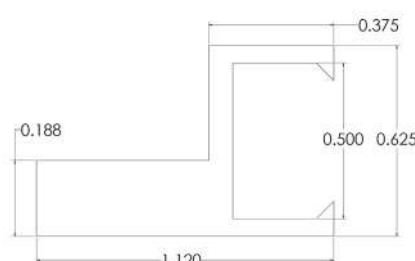

Fig. 2.2

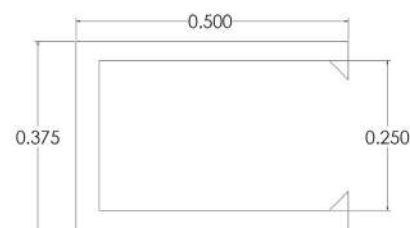

Fig. 2.3

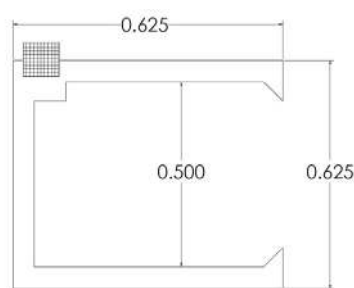

Fig. 2.4

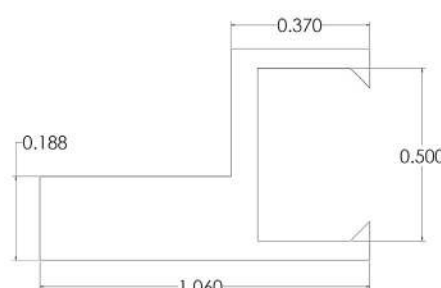

Fig. 2.5

Series 300

Knitted Wire Mesh Materials

DESCRIPTION

Wire mesh shielding utilizes single-strand wire (available in a wide range of metals) which is knitted and formed into pre-specified cross-sections yielding an economical and reliable gasket for use in a variety of shielding applications. Cross-sections vary from round, rectangular, round with a fin, and double round with a fin inter-connector.

APPLICATION

Wire mesh gaskets are best suited for those applications where a) high shielding effectiveness is required b) an environmental seal is not needed and c) the gasket must conform to an irregular surface. Panel gaskets, cable wrapping, door gaskets and static discharge washers are just a few of the commonly chosen applications.

COMPATIBILITY

Compatibility to mating surfaces, as well as environmental conditions, must be considered when choosing the mesh gasket used. Compatible metals are listed together for quick reference. Metals from one group should not be used with metals from another group without first applying a protective coating.

For galvanic compatibility issues with metal filled gaskets reference MIL-STD-889 or contact applications engineering for assistance.

PART NUMBERING

WIRE TYPE

- 1 = Monel
- 2 = SnCuFe
- 3 = Aluminum
- 4 = SnPhBronze
- 5 = Ag Brass
- 6 = Stainless

30X-XXXX

CROSS SECTION

- 1 = Rectangular
- 2 = Round
- 3 = Dumbbell
- 4 = Tadpole
- 5 = Compressed Mesh Unit



MATERIALS Listed below are the wire mesh materials most commonly used for EMI/RFI shielding.\*

Part No.	Wire	Specification	Diameter
301	Monel	QQ-N-281	.0045
302	SnCuFe	ASTM B520	.0045
303	Aluminum	5056 Alloy	.0050
304	SnPhBronze	ASTM B105	.0045
305	AG Brass	QQ-W-321	.0045
306	Stainless	Alloy 304	.0060

AVAILABLE CROSS-SECTIONS

Part No.	Cross-Section
1XXX	Rectangular Cross-Section
2XXX	Round Cross-Section
3XXX	Dumbbell Cross-Section
4XXX	Tadpole Cross-Section
5XXX	Compressed Mesh Unit

\*Other metals are available by request.

TYPICAL PERFORMANCE CHARACTERISTICS

Material	Monel	SnCuFe	Aluminum	SnPhBronze
Shielding db: 100 KHz	45	50	40	65
10 MHz	115	115	100	120
500 KHz	110	110	90	110
1 GHz	95	95	80	95
Closure Force: (min. psi)	10	10	10	10

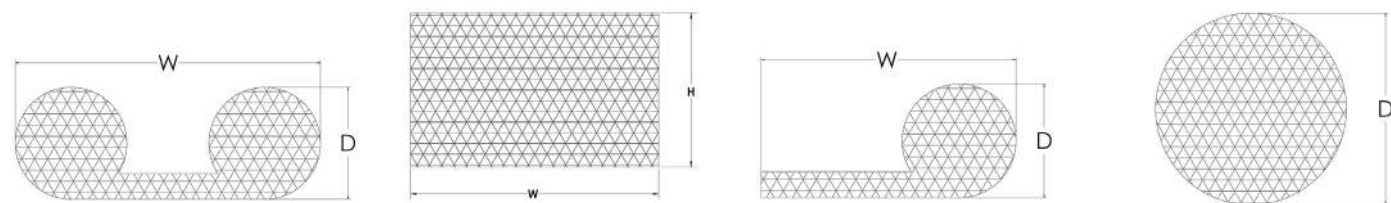

**DUMBBELL GASKET**

Part No.	W (in.)	D (in.)
3050	0.062	0.375
3051	0.062	0.500
3052	0.062	0.625
3053	0.062	0.675
3054	0.062	0.750
3055	0.062	0.875
3056	0.093	0.500
3057	0.125	0.500
3058	0.125	0.625
3059	0.125	0.675
3060	0.125	0.750
3061	0.125	0.875
3062	0.125	1.000
3063	0.187	0.625
3064	0.187	0.750
3065	0.187	0.875
3066	0.187	1.000
3067	.0250	0.750
3068	0.250	0.875
3069	0.250	1.000
3070	0.250	1.250
3071	0.375	1.000
3072	0.375	1.250

**REGULAR GASKET**

Part No.	W (in.)	H (in.)
1001	0.062	0.062
1002	0.062	0.125
1003	0.062	0.187
1004	0.062	0.250
1005	0.062	0.312
1006	0.062	0.375
1007	0.062	0.500
1033	0.062	0.625
1034	0.062	0.750
1035	0.062	1.000
1008	0.093	0.093
1009	0.093	0.125
1010	0.093	0.187
1011	0.093	0.250
1012	0.093	0.312
1013	0.093	0.375
1014	0.093	0.500
1036	0.093	0.625
1015	0.125	0.125
1037	0.125	0.156
1016	0.125	0.187
1017	0.125	0.250
1018	0.125	0.312
1019	0.125	0.375
1020	0.125	0.500
1038	0.125	0.625
1039	0.125	0.750
1040	0.125	1.000
1021	0.187	0.187
1022	0.187	0.250
1023	0.187	0.312
1024	0.187	0.375
1025	0.187	0.500
1041	0.187	0.625
1042	0.187	0.750
1043	0.187	1.000
1026	0.250	0.250
1027	0.250	0.312
1028	0.250	0.375
1029	0.250	0.500
1044	0.250	0.625

**TADPOLE GASKET**

Part No.	D (in.)	W (in.)
4050	0.062	0.375
4051	0.062	0.500
4052	0.062	0.625
4053	0.062	0.750
4054	0.093	0.375
4088	0.093	0.500
4055	0.093	0.750
4056	0.125	0.375
4057	0.125	0.437
4067	0.187	0.625
4068	0.187	0.750
4069	0.187	0.875
4070	0.250	0.500
4071	0.250	0.625
4072	0.250	0.750
4073	0.250	0.875
4074	0.250	1.000
4075	0.312	0.625
4076	0.312	0.750
4077	0.312	0.875
4058	0.125	0.500
4059	0.125	0.562
4060	0.125	0.625
4061	0.125	0.750
4062	0.156	0.500
4063	0.156	0.625
4064	0.156	0.750
4065	0.187	0.437
4066	0.187	0.500
4078	0.375	0.625
4079	0.375	0.750
4080	0.375	0.875
4081	0.375	1.000
4082	0.437	0.750
4083	0.437	0.875
4084	0.437	1.000
4085	0.500	0.750
4086	0.500	0.875
4087	0.500	1.000

**ROUND GASKET**

Part No.	D (in.)
2001	0.062
2002	0.093
2003	0.125
2004	0.156
2005	0.187
2006	0.250
2007	0.312
2008	0.375
2009	0.437
2010	0.500

Rectangular Strip (in.)
0.062 to 0.188; +0.015, -0.000
Over 0.188 to 0.375; +0.032, -0.000
Over 0.375 to 0.500; +0.047, -0.000
Over 0.500 to 1.000; +0.062, -0.000

Round Strip (in.)
0.062 to 0.125; +0.015, -0.000
Over 0.125 to 0.188; +0.032, -0.000
Over 0.188 to 0.375; +0.047, -0.000
Over 0.375 to 0.750; +0.062, -0.000

Single or Double Round with Fin (overall width, in.)
Under and including 1.00; ± 0.06
Over 1.00; ± 0.12

Fabricated Mesh Strip Gaskets (in.)
0 to 4.9; ± 0.03
5.0 to 10.0; ± 0.06
Over 10.00; ± 0.06

Series 301  
**Mesh Tape**

This mesh tape is used for a variety of electronic shielding applications. The cable or harness assembly is wrapped with the mesh using a .25 in. overlap to insure proper continuity. The mesh wrap is then terminated on one end (or preferably both ends) to the ground.

Mesh tape is also available in alternative metals such as SnCuFe wire mesh (tin-plated, copper-clad, steel wire) and SnPhBronze wire mesh (tin plated, phosphor bronze wire). Please contact an application engineer if assistance is needed.

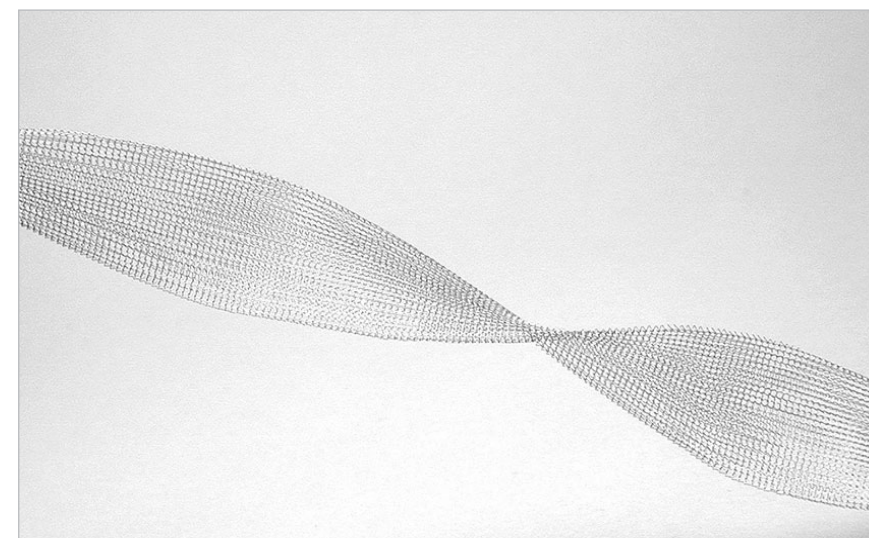

**MESH TAPE SNCUFE WIRE — 1 IN. WIDE**

Nolato Jabar	Mil-Spec Part No.	Length (Roll)
395-001	90095-001	25 ft.
395-002	90095-002	100 ft.
395-003	90095-003	1000 ft.

**MESH TAPE (PHYSICAL MAKE-UP, WIDTHS, AND ELECTRICAL CHARACTERISTICS)**

Property	UM	Value
Wire Type		Monel
Wire Diameter	in.	0.0045 in.
<b>Available Widths</b>		
Part Number 301-6005	in.	2.0 in.
Part Number 301-6004	in.	1.5 in.
Part Number 301-6003	in.	1.0 in.
Part Number 301-6002	in.	0.75 in.
Part Number 301-6001	in.	0.50 in.
Pull Strength	#	40-50 #
Solderability	—	Very Good
Corrosion Resistance	—	Very Good
<b>Shielding Effectiveness</b>		
100 KHz	dB	45 dB
10 MHz	dB	60 dB
1 GHz	dB	40 dB
10 GHz	dB	25 dB

Series 400

# Wire Mesh and Elastomer Combinations

**DESCRIPTION**

Wire mesh and elastomer combinations are produced by vulcanizing shielding mesh with an elastomer—either silicone or Neoprene. This creates a reliable, low-cost, shielding gasket with environmental sealing properties for use in military and electronic applications.

**APPLICATION**

Ideal for use as enclosure, window, and panel gaskets and where substantial joint unevenness is apparent. Choice of shielding mesh should take into consideration the type of metals being interfaced to insure compatibility and the attenuation required. The elastomer should be chosen to meet your compression, temperature, and sealing needs. This elastomer is available with an adhesive back.



**SPECIFICATIONS**

Listed in the table to the right are the most commonly used wire mesh and elastomer types. Others are available upon request.

**PART NUMBERING**

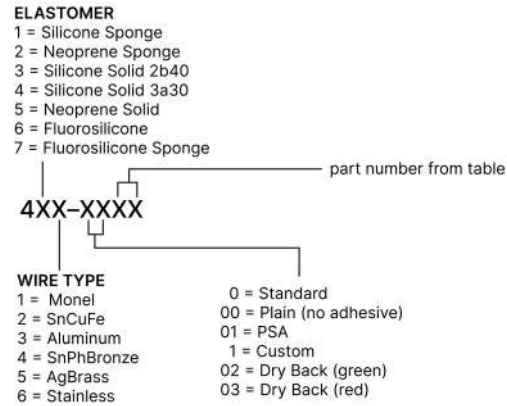

**TOLERANCE LIMITATIONS**

From	To	Solid Elastomer	Sponge Elastomer	Wire Mesh
.062	.093	+ / - .015	+ / - .016	+ .016 / -.000
.125	.188	+ / - .015	+ / - .031	+ .031 / -.000
.250	.500	+ / - .032	+ / - .047	+ .047 / -.000
.625	1.00	+ / - .047	+ / - .094	+ .062 / -.000

**COMMONLY USED ELASTOMER TYPES**

Identifier	Elastomer	Specification	Color
1	Silicone Sponge	AMS 3195	Gray/Red
2	Neoprene Sponge	Mil-R-6130	Black
3	Silicone Solid	A-A-59588 (2b40)	Gray/Red
4	Silicone Solid	A-A-59588 (3a30)	Gray/Red
5	Neoprene Solid	Mil-R-6855	Black
6	Fluorosilicone	Mil-R-25988 (50)	Blue
7	Fluorosilicone Sponge	—	Blue

**COMMONLY USED WIRE TYPES**

Identifier	Wire	Specification	Diameter
1	Monel	QQ-N-281	.0045
2	SnCuFe	ASTM B520	.0045
3	Aluminum	AMS 4182	.0050
4	SnPhBr	ASTM B105	.0045
5	AgBrass	QQ-W-321	.0045
6	Stainless Steel	Alloy 304	.0060

**TYPICAL SHIELDING EFFECTIVENESS**

Material	Monel	SnCuFe	Aluminum	SnPhBronze
Shielding Effectiveness				
100 KHz	45	50	40	65
10 MHz	115	115	100	120
500 KHz	110	110	90	110
1 GHz	95	95	80	95
Closure Force (min. psi)	10	10	10	10
Compression Set (40 min. psi)	7%	9%	12%	9%

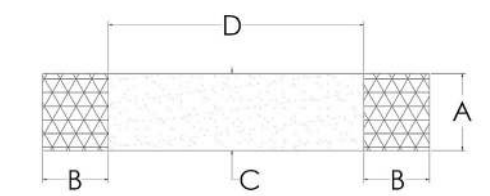
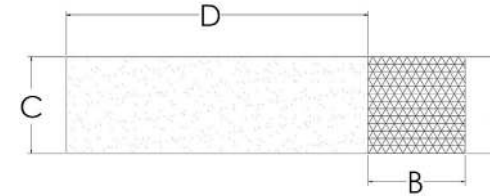

**COMMON MESH / ELASTOMER COMBOS**

Part No.	A (in.)	B (in.)	C (in.)	D (in.)
0X01	.062	.125	.062	.125
0X02	.062	.125	.062	.250
0X03	.062	.125	.062	.375
0X04	.062	.125	.062	.500
0X05	.062	.125	.062	.625
0X06	.062	.125	.062	1.00
0X07	.093	.125	.093	.125
0X08	.093	.125	.093	.250
0X09	.093	.125	.093	.375
0X10	.093	.125	.093	.500
0X11	.093	.125	.093	.625
0X12	.093	.125	.093	1.00
0X13	.093	.188	.093	.125
0X14	.093	.188	.093	.250
0X15	.093	.188	.093	.375
0X16	.093	.188	.093	.500
0X17	.093	.188	.093	.625
0X18	.093	.188	.093	1.00
0X19	.125	.125	.093	.125
0X20	.125	.125	.093	.250
0X21	.125	.125	.093	.375
0X22	.125	.125	.093	.500
0X23	.125	.125	.093	.625
0X24	.125	.125	.093	.875
0X25	.125	.125	.093	1.00
0X26	.125	.125	.125	.125
0X27	.125	.125	.125	.250
0X28	.125	.125	.125	.375
0X29	.125	.125	.125	.500
0X30	.125	.125	.125	.625
0X31	.125	.125	.125	.875
0X32	.125	.125	.125	1.00
0X33	.125	.187	.125	.187
0X34	.125	.187	.125	.312
0X35	.125	.250	.125	.250

Part No.	A (in.)	B (in.)	C (in.)	D (in.)
0X36	.125	.250	.125	.500
0X37	.125	.250	.125	.750
0X38	.187	.125	.156	.250
0X39	.187	.125	.156	.375
0X40	.187	.125	.156	.500
0X41	.187	.125	.156	.875
0X42	.187	.125	.187	.125
0X43	.187	.125	.187	.250
0X44	.187	.125	.187	.375
0X45	.187	.125	.187	.625
0X46	.187	.125	.187	.875
0X47	.187	.187	.187	.187
0X48	.187	.187	.187	.312
0X49	.187	.187	.187	.563
0X50	.187	.187	.187	.812
0X51	.188	.250	.188	.250
0X52	.188	.250	.188	.375
0X53	.188	.250	.188	.500
0X54	.188	.250	.188	.750
0X55	.250	.125	.250	.125
0X56	.250	.125	.250	.250
0X57	.250	.125	.250	.375
0X58	.250	.125	.250	.500
0X59	.250	.125	.250	.625
0X60	.250	.125	.250	.875
0X61	.250	.250	.250	.125
0X62	.250	.250	.250	.250
0X63	.250	.250	.250	.500
0X64	.250	.250	.250	.750
0X65	.375	.250	.375	.250
0X66	.375	.250	.375	.500
0X67	.375	.250	.375	.750
0X68	.375	.375	.375	.125
0X69	.375	.375	.375	.375
0X70	.375	.375	.375	.125

**TWIN MESH ELASTOMER COMBOS**

Part No.	A (in.)	B (in.)	C (in.)	D (in.)
0X75	.093	.093	.093	.312
0X76	.125	.125	.125	.250
0X77	.125	.125	.125	.375
0X78	.125	.125	.125	.500
0X79	.125	.125	.125	.750
0X80	.125	.250	.125	.500
0X81	.187	.187	.156	.250
0X82	.187	.187	.156	.375
0X83	.187	.187	.187	.250
0X84	.187	.187	.187	.375
0X85	.250	.250	.250	.250

Series 500

# Wire Mesh Over Elastomer

**DESCRIPTION**

Wire mesh over elastomer is a double layer of wire mesh that is knitted over a round or rectangular core of elastomer. The mesh layers provide EMI/RFI shielding while the elastomer acts as a dust and moisture seal.

**APPLICATION**

A wire mesh over elastomer combination is used with doors and cabinets where surfaces may be uneven and low closure forces exist. For applications that require cut-to-length pieces (that must be terminated with adhesive to stop the fraying of the knitted mesh) this product is manufactured with a co-extrusion method which results in a self-terminating material supplied in continuous lengths for use in a production line. Our self-terminating can be specified by replacing the 0 in the fifth digit of our part number with a 1 (silicone cores only).



**PART NUMBERING**

**ELASTOMER**

- 1 = Neoprene Sponge Core
- 2 = Silicone Sponge Core
- 3 = Neoprene Solid Core
- 4 = Silicone Solid Core
- 5 = Silicone Tube (.040 wall)
- 6 = Neoprene Tube (.040 wall)

5XX-XXXX

**WIRE TYPE**

- 1 = Monel
- 2 = SnCuFe
- 3 = Aluminum
- 4 = SnPhBronze
- 5 = AgBrass
- 6 = Stainless

**CROSS SECTION**

- 1 = Rectangular
- 2 = Round
- 3 = Dumbbell
- 4 = Tadpole

part number from table

**AVAILABLE ELASTOMERS**

Identifier	Elastomer
1	Neoprene Sponge Core
2	Silicone Sponge Core
3	Neoprene Solid Core
4	Silicone Solid Core
5	Silicone Tube (.040 wall thickness)
6	Neoprene Tube (.040 wall thickness)

**AVAILABLE WIRE MESH\***

Identifier	Wire	Specification	Diameter
1	Monel	QQ-N-281b	.0045
2	SnCuFe	ASTM B520	.0045
3	Aluminum	AMS 4182	.0050
4	SnPhBronze	ASTM B105	.0045
5	AgBrass	QQ-W-321	.0045
6	Stainless	Alloy 304	.0060

\*Other metals available upon request.

**AVAILABLE CROSS-SECTIONS**

Part No.	Cross-Section
1XXX	Rectangular
2XXX	Round
3XXX	Dumbbell
4XXX	Tadpole

**TYPICAL SHIELDING EFFECTIVENESS**

Material:	Monel	SnCuFe	Aluminum	SnPhBronze
Shielding db: 100 KHz	45	50	40	65
10 MHz	115	115	100	120
500 MHz	110	110	90	110
1 GHz	95	95	80	95
Closure Force (min. psi)	10	10	10	10

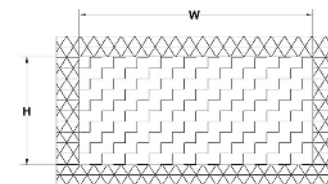

REGULAR GASKET

Part No.	W (in.)	H (in.)
1001	0.062	0.062
1002	0.062	0.125
1003	0.062	0.187
1004	0.062	0.250
1005	0.062	0.312
1006	0.062	0.375
1007	0.062	0.500
1033	0.062	0.625
1034	0.062	0.750
1035	0.062	1.000
1008	0.093	0.093
1009	0.093	0.125
1010	0.093	0.187
1011	0.093	0.250
1012	0.093	0.312
1013	0.093	0.375
1014	0.093	0.500
1036	0.093	0.625
1015	0.125	0.125
1037	0.125	0.156
1016	0.125	0.187
1017	0.125	0.250
1018	0.125	0.312
1020	0.125	0.500
1038	0.125	0.625
1039	0.125	0.750
1040	0.125	1.000
1021	0.187	0.187
1022	0.187	0.250
1019	0.125	0.375
1023	0.187	0.312
1024	0.187	0.375
1025	0.187	0.500
1041	0.187	0.625
1042	0.187	0.750
1043	0.187	1.000
1026	0.250	0.250
1027	0.250	0.312
1028	0.250	0.375
1029	0.250	0.500
1030	0.312	0.312
1031	0.375	0.375
1032	0.375	0.625
1044	0.250	0.625

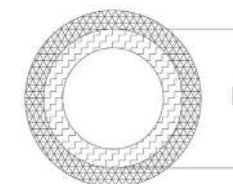

ROUND GASKET

Part No.	D (in.)
2001	0.062
2002	0.093
2003	0.125
2004	0.156
2005	0.187
2006	0.250
2007	0.312
2008	0.375
2009	0.437
2010	0.500

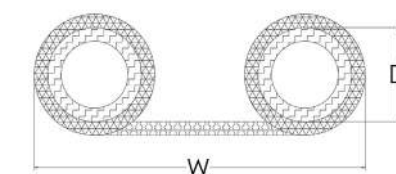

DUMBBELL GASKET

Part No.	D (in.)	W (in.)
3050	0.062	0.375
3051	0.062	0.500
3052	0.062	0.625
3053	0.062	0.675
3054	0.062	0.750
3055	0.062	0.875
3056	0.093	0.500
3057	0.125	0.500
3058	0.125	0.625
3059	0.125	0.675
3060	0.125	0.750
3061	0.125	0.875
3062	0.125	1.000
3063	0.187	0.625
3064	0.187	0.750
3065	0.187	0.875
3066	0.187	1.000
3067	0.250	0.750
3068	0.250	0.875
3069	0.250	1.000
3070	0.250	1.250
3071	0.375	1.000
3072	0.375	1.250

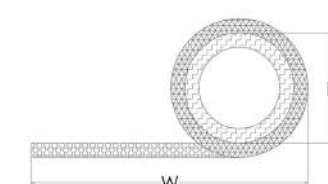

TADPOLE GASKET

Part No.	D (in.)	W (in.)
4050	0.062	0.375
4051	0.062	0.500
4052	0.062	0.625
4053	0.062	0.750
4054	0.093	0.375
4088	0.093	0.500
4055	0.093	0.750
4056	0.125	0.375
4057	0.125	0.437
4058	0.125	0.500
4059	0.125	0.562
4060	0.125	0.625
4061	0.125	0.750
4062	0.156	0.500
4063	0.156	0.625
4064	0.156	0.750
4065	0.187	0.437
4066	0.187	0.500
4067	0.187	0.625
4068	0.187	0.750
4069	0.187	0.875
4070	0.250	0.500
4071	0.250	0.625
4072	0.250	0.750
4073	0.250	0.875
4074	0.250	1.000
4075	0.312	0.625
4076	0.312	0.750
4077	0.312	0.875
4078	0.375	0.625
4079	0.375	0.750
4080	0.375	0.875
4081	0.375	1.000
4082	0.437	0.750
4083	0.437	0.875
4084	0.437	1.000
4085	0.500	0.750
4086	0.500	0.875
4087	0.500	1.000

Series 600

# Wire Oriented in Silicone

**DESCRIPTION**

Wire oriented in silicone is produced from a combination of specification grade silicone and wire used in sheet and strip form. The silicone elastomer acts as an environmental seal while the wires provide excellent conductivity to establish EMI/RFI integrity. It is available in both solid and sponge silicone variations.

**APPLICATION**

Primarily suggested for use in gasket applications requiring high levels of attenuation along with a moisture seal. It's cost effectiveness makes it ideal for commercial shielding. Available with or without PSA (pressure sensitive adhesive) in sheet, strip, or custom form.

**AVAILABILITY**

Each of the materials are available in a variety of cross sections and die cut configurations. In order to determine the full part number for the needed material use the following system.

**PART NUMBERING**

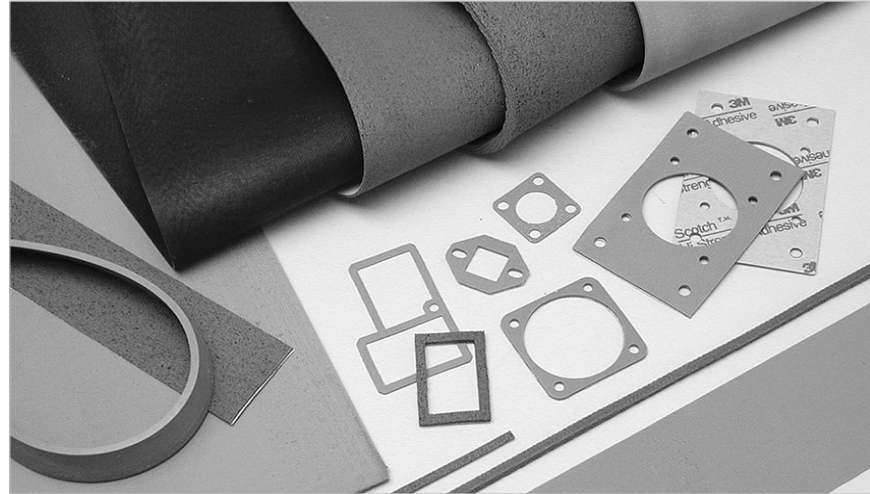
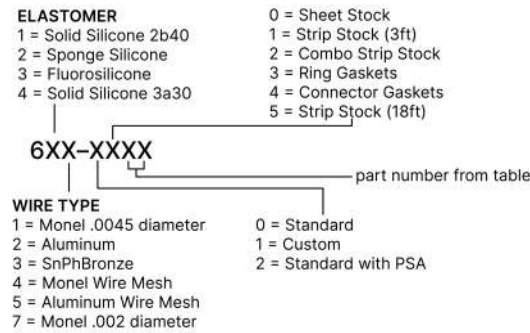

**AVAILABLE ELASTOMERS**

Description	Specification
Solid Silicone Elastomer	A-A-59588 2b40
Sponge Silicone	AMS 3195
Fluorosilicone	Mil-R-25988 Gr50
Solid Silicone	A-A-59588 3a30
Inquire about elastomers not listed.	

**AVAILABLE WIRES**

Description	Specification	Diameter
Monel Wire	QQ-N-281	.0045
Aluminum Wire	Alloy 5056	.005
SnPhBronze	ASTM B105	.0045
Monel Wire Mesh	QQ-N-281	.0045
Aluminum Wire Mesh	Alloy 5056	.005
Monel Wire	QQ-N-281	.002

**TYPICAL PERFORMANCE CHARACTERISTICS**

Part No. Designator	Solid Silicone and Fluorosilicone Elastomers						Silicone Sponge Elastomer		
	611	612	613	631	632	633	621	622	623
Shielding dB 200 KHz	70	70	70	70	70	85	70	70	70
100 MHz	125	100	130	125	100	130	120	85	130
1.0 GHz	125	100	125	125	100	125	125	70	125
Fuel/Solvent Resistant	No	No	No	Yes	Yes	Yes	No	No	No
Closing Force (psi)	25-100	25-100	25-100	25-100	25-100	25-100	5-50	5-50	5-50
Compression Set	25%	25%	25%	25%	25%	25%	25%	25%	25%
Temperature range (C)	-65/200	-65/200	-65/200	-55/200	-55/200	-55/200	-65/200	-65/200	-65/200
EMP Survivability	Yes	Yes	Yes	Yes	Yes	Yes	Yes	Yes	Yes
Color	Gray	Gray	Gray	Blue	Blue	Blue	Gray	Gray	Gray
Wire Count/ sq. in.	900	900	900	900	900	900	650	650	650

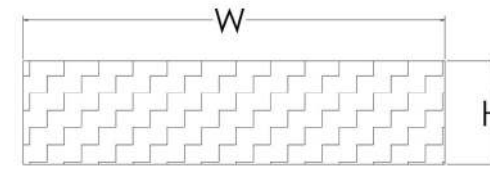

Standard Strip 6XX-01XX

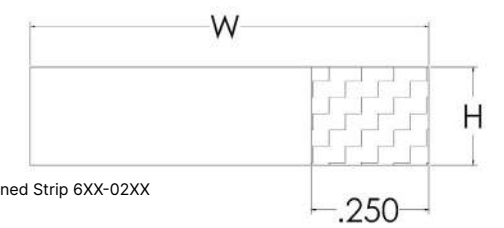

Portioned Strip 6XX-02XX

**STANDARD STRIP / SHEET STOCK 3 FT. LENGTHS**

Part No.	H (in.)	W (in.)	Part No.	H (in.)	W (in.)
0005	.032	3.0	0027	.125	6.0
0006	.032	4.5	0028	.125	9.0
0007	.032	6.0	0029	.156	3.0
0008	.032	9.0	0030	.156	4.5
0009	.045	3.0	0031	.156	6.0
0010	.045	4.5	0032	.156	9.0
0011	.045	6.0	0033	.188	3.0
0012	.045	9.0	0034	.188	4.5
0013	.055	3.0	0035	.188	6.0
0014	.055	4.5	0036	.188	9.0
0015	.055	6.0	0037	.250	3.0
0016	.055	9.0	0038	.250	4.5
0017	.062	3.0	0039	.250	6.0
0018	.062	4.5	0040	.250	9.0
0019	.062	6.0	0041	.312	3.0
0020	.062	9.0	0042	.312	4.5
0021	.093	3.0	0043	.312	6.0
0022	.093	4.5	0044	.312	9.0
0023	.093	6.0	0045	.375	3.0
0024	.093	9.0	0046	.375	4.5
0025	.125	3.0	0047	.375	6.0
0026	.125	4.5	0048	.375	9.0

**PORTIONED STRIP / SHEET STOCK**

Part No.	H (in.)	W (in.)	Part No.	H (in.)	W (in.)	Part No.	H (in.)	W (in.)
0101	.062	.062	0134	.125	.625	0167	.250	.500
0102	.062	.093	0135	.125	.750	0168	.250	.625
0103	.062	.125	0136	.125	1.00	0169	.250	.750
0104	.062	.156	0137	.156	.062	0170	.250	1.00
0105	.062	.188	0138	.156	.093	0171	.375	.125
0106	.062	.250	0139	.156	.125	0172	.375	.250
0107	.062	.312	0140	.156	.156	0173	.375	.375
0108	.062	.375	0141	.156	.188	0174	.375	.500
0109	.062	.500	0142	.156	.250	0175	.375	.625
0110	.062	.625	0143	.156	.312	0176	.375	.750
0111	.062	.750	0144	.156	.375	0177	.375	1.00
0112	.062	1.00	0145	.156	.500	0178	.500	.250
0113	.093	.062	0146	.156	.625	0179	.500	.375
0114	.093	.093	0147	.156	.750	0180	.500	.500
0115	.093	.125	0148	.156	1.00	0181	.500	.625
0116	.093	.156	0149	.188	.062	0182	.500	.750
0117	.093	.188	0150	.188	.093	0183	.500	1.00
0118	.093	.250	0151	.188	.125	0184	.625	.250
0119	.093	.312	0152	.188	.156	0185	.625	.375
0120	.093	.375	0153	.188	.188	0186	.625	.500
0121	.093	.500	0154	.188	.250	0187	.625	.625
0122	.093	.625	0155	.188	.312	0188	.625	.750
0123	.093	.750	0156	.188	.375	0189	.625	1.00
0124	.093	1.00	0157	.188	.500	0190	.750	.250
0125	.125	.062	0158	.188	.625	0191	.750	.375
0126	.125	.093	0159	.188	.750	0192	.750	.500
0127	.125	.125	0160	.188	1.00	0193	.750	.625
0128	.125	.156	0161	.250	.062	0194	.750	.750
0129	.125	.188	0162	.250	.093	0195	.750	1.00
0130	.125	.250	0163	.250	.125	0196	1.00	.250
0131	.125	.312	0164	.250	.188	0197	1.00	.500
0132	.125	.375	0165	.250	.250	0198	1.00	.750
0133	.125	.500	0166	.250	.375	0199	1.00	1.00

**STRIP LENGTH AVAILABILITY**

Thickness (in.)	Width (in.)	Maximum Length (in.)
0.032	0.062 – 9.00	36 in.
0.062 – 1.0	0.062 – 0.250	216 in.
0.125 – 1.0	0.250 – 0.375	132 in.

**TOLERANCES**

Dimension	Thickness	Width
0.032 in. – 0.055 in.	+.010 in. / - 0.005 in.	N/A
0.062 in. – 0.250 in.	+ / - .010 in.	+ / - .016 in.
0.251 in. – 0.750 in.	+ / - .010 in.	+ / - .031 in.
0.751 in. – 1.50 in.	+ / - .010 in.	+ / - .047 in.
3.0 in.	N/A	Minimum
4.5 in.	N/A	Minimum
6.0 in.	N/A	Minimum
9.0 in.	N/A	Minimum



Series 800

# Conductive Particle-filled Elastomers

**DESCRIPTION**

This conductive silicone and fluorosilicone material is manufactured to both Mil Spec and commercial standards with M83528 being the most typical EMI specification. It accommodates a wide spectrum of shielding solutions for the optimal needs of the aerospace and telecommunication markets.

**APPLICATION**

Certain end-use applications may require high shielding effectiveness, environmental sealing, reliability and durability. These silicone elastomers fulfill those needs. The part number system segregates the various types of conductive elastomers available. Products beginning with 8xx- depict the use of small particles to establish a conductive path within the elastomer—yielding a highly versatile group of gasket materials for use in EMI/RFI suppression. Each compound has its own unique properties, therefore it is essential that a distinction be made. The second digit in the 800 series specifies the type of elastomer to be used and the grade of the final product.

If a 1 appears, the next three digits are assigned from our numerical listing of custom parts. If the part has been determined to be standard the next digit will determine the product family:

**PART NUMBERING**

- |   |                           |
|---|---------------------------|
| <b>ELASTOMER</b>                                | <b>PRODUCT</b>            |
| 0 = Standard Silicone (Mil grade)               | 1 = Sheet Stock           |
| 1 = Fluorosilicone (Mil grade)                  | 2 = Round Extrusion       |
| 2 = EPDM (Mil grade)                            | 3 = Rectangular Extrusion |
| 4 = Conductive/Non-conductive Combo (Mil grade) | 4 = "D-shaped" Extrusion  |
| 5 = Standard Silicone (Commercial grade)        | 5 = "P-shaped" Extrusion  |
| 6 = Fluorosilicone (Commercial grade)           | 6 = "U-channel" Extrusion |
| 7 = O-ring                                      | 7 = O-ring                |
| 8 = One Part Form-in-place Gasket               | 8 = Flat Washer           |
| 9 = Two Part Room Temp Cure "Form-in-place"     | 9 = Standard Connector    |
|   | 28 = Standard Waveguide   |

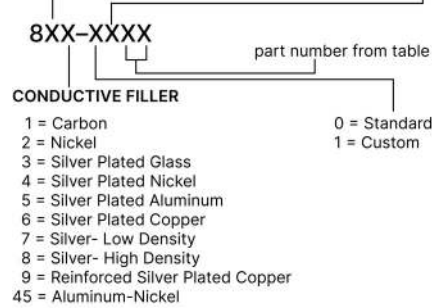

The third digit classifies the conductive filler type used in the compound. The different classes are as follows:

80X	Military Grade / Standard Silicone	8X1	Carbon
81X	Military Grade / Fluorosilicone	8X2	Nickel
82X	Military Grade / EPDM	8X3	Silver-plated Glass
84X	Military Grade/ Combination: Conductive / Non-conductive	8X4	Silver-plated Nickel
85X	Commercial Grade / Standard Silicone	8X5	Silver-plated Aluminum
86X	Commercial Grade / Fluorosilicone	8X6	Silver-plated Copper
88X	One Part Form-In-Place Gasket Material	8X7	Silver — Low Density
89X	Two Part, Room Temperature Cure, Form-In-Place Material	8X8	Silver — High Density
		8X9	Reinforced Silver-plated Copper

The next set of four digits establishes the end products dimensional characteristics. The first of these four tell us whether the part is of a standard configuration or a custom design.

<b>8XX-0XXX—Standard</b>	
<b>8XX-1XXX—Custom</b>	
8XX-01XX	Sheet Stock
8XX-02XX	Extrusion — Round
8XX-03XX	Extrusion — Rectangular
8XX-04XX	Extrusion — D-Shaped
8XX-05XX	Extrusion — P-Shaped
8XX-06XX	Extrusion — U-Channel
8XX-07XX	O-Rings
8XX-08XX	Flat Washer
8XX-09XX	Standard Connector
8XX-28XX	Standard Waveguide

**PERFORMANCE CHARACTERISTICS PER MIL-DTL-83528 and COMMERCIAL**

Series	U of M	801	802	822	812	803	813	804	814	805	815
Filler	—	C	Ni/Gr	Ni/Gr	Ni/Gr	AG/Glass	AG/Glass	AG/Ni	AG/Ni	AG/Al	AG/Al
Elastomer	—	Silicone	Silicone	EPDM	Fluorosilicone	Silicone	Fluorosilicone	Silicone	Fluorosilicone	Silicone	Fluorosilicone
MIL-83528 TYPE	—	—	—	N/A	—	M	—	L	—	B	D
Operating Temp. (°C)	Min Max	-55 +200	-55 +150	-30 +100	-55 +150	55 +160	55 +160	-55 +125	-55 +160	-55 +160	-55 +160
Hardness	Shore A	70	65	75	65	65	65	75	70	65	70
Specific Gravity	g/cc	1.2	1.95	2.1	1.95	1.9	1.9	4.0	4.4	2.0	2.0
Compression Deflection	% min	3.5	3.5	2.0	3.0	3.5	3.5	3.5	3.5	3.5	3.5
Tensile Strength	#/in sq	650	150	200	150	200	200	200	180	200	180
Elongation	Min Max	100 —	100 —	75 —	100 —	100 300	100 300	100 300	60 260	100 300	60 260
Compression Set	%	40	35	40	25	30	30	32	30	32	30
Tear Strength	#/in	40	40	70	35	30	30	30	35	30	35
Volume Resistivity	Ohm-cm	7.0	.10	5	0.1	.006	.006	.005	.012	.008	.012
Shielding Effectiveness as tested per MIL-DTL-83528	100 MHz 500 MHz 2 GHz 10 GHz	80 80 60 50	100 100 100 100	90 90 90 90	100 100 100 100	100 100 90 90	100 100 90 90	120 120 120 110	120 120 115 110	120 120 115 115	120 120 115 115

Series	U of M	806 - A	816	806 - K	807	808 - E	818	808 - H	809
Filler	—	Si/Cu	Si/Cu	Si/Cu	Si Low Density	Si Pure	Si Pure	Si	Si/Cu
Elastomer	—	Silicone	Fluorosilicone	Silicone	Silicone	Silicone	Fluorosilicone	Silicone	Silicone w/ Cu Mesh
MIL-83528 TYPE	—	A	C	K	J*	E	F	H	G*
Operating Temp. (°C)	Min Max	-55 +125	-55 +125	-45 +125	-55 +160	-55 +160	-65 +160	-55 +160	-45 +125
Hardness	Shore A	65	75	85	45	65	75	80	80
Specific Gravity	g/cc	3.5	4.1	3.8	1.8	3.5	4.0	4.0	4.75
Compression Deflection	(% min)	3.5	3.5	2.5	8.0	2.5	3.5	2.5	2.5
Tensile Strength	(#/in sq)	200	180	400	150	300	250	400	600
Elongation	Min Max	100 300	100 300	100 300	50 250	200 500	100 300	90 290	20 N/A
Compression Set	(%)	32	35	35	35	45	60	60	N/A
Tear Strength	(#/in)	25	35	40	20	50	40	60	70
Volume Resistivity	(ohm-cm)	.004	.010	.005	.010	.002	.002	.005	.007
Shielding Effectiveness as tested per Mil-DTL-83528	100 MHz 500 MHz 2 GHz 10 GHz	120 120 120 120	120 120 120 115	120 120 120 120	100 100 90 90	120 120 120 120	120 120 120 120	120 120 120 120	120 120 120 120

\*Designed to meet requirements. Not certified.

Series	8045	8145	852	853	854	855	856	857	858
Filler	Ni/Al	Ni/Al Fluorosilicone	Ni Pure	Si/Glass	Si/Ni	Si/Al	Si/Cu	Si Low Density	Si Pure
Operating Temp. (C) MIN	-55	-55	-55	-55	-55	-55	-55	-55	-65
Operating Temp. (C) MAX	+125	+125	+125	+170	+180	+200	+125	+160	+180
Specific Gravity	1.88	1.96	3.05	1.8	4.0	2.0	3.5	1.7	4.0
Hardness Available (Shore A)	65	75	45-75	45-75	45-75	45-75	45-75	45-75	45-75
Tensile Strength (#/in. sq.)	200	200	400	200	200	200	200	150	200
Elongation* (%)	130	65	300	280	300	280	300	100	300
Tear Strength* (#/in.)	60	40	40	35	35	35	35	25	60
Volume Res.* (ohm-cm.)	.15	20	2.0	.05	.06	.08	.06	.1	.04
Shielding Effectiveness (20 MHz - 1 GHz) min.	115	115	60	75	80	75	85	70	85

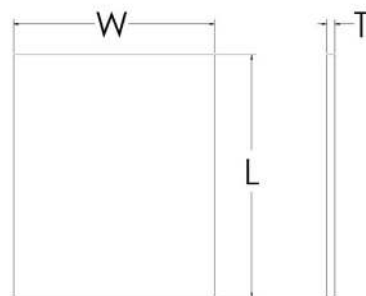

**STANDARD SHEET**

Part No.	Thickness (in.)	W (in.)	L (in.)	Tolerance (in.)
0101	.020	10	10	+/- .004
0102	.032	10	10	+/- .004
0103	.062	10	10	+/- .005
0104	.093	10	10	+/- .007
0105	.125	10	10	+/- .010
0106	.020	12	12	+/- .004
0107	.032	12	12	+/- .004
0108	.062	12	12	+/- .005
0109	.093	12	12	+/- .007
0110	.125	12	12	+/- .010
0111	.020	15	20	+/- .004
0112	.032	15	20	+/- .005
0113	.062	15	20	+/- .005
0114	.093	15	20	+/- .008
0115	.125	15	20	+/- .010
0116	.020	17.8	20.5	+/- .005
0117	.032	17.8	20.5	+/- .005
0118	.062	17.8	20.5	+/- .005
0119	.093	17.8	20.5	+/- .008
0120	.125	17.8	20.5	+/- .010
0121	.027	10	10	+/- .004
0122	.030	10	10	+/- .004
0123	.040	10	10	+/- .004
0124	.047	10	10	+/- .004
0125	.060	10	10	+/- .005
0126	.027	12	12	+/- .004
0127	.030	12	12	+/- .004
0128	.040	12	12	+/- .004
0129	.047	12	12	+/- .004
0130	.060	12	12	+/- .005
0131	.027	15	20	+/- .004
0132	.030	15	20	+/- .004
0133	.040	15	20	+/- .005
0134	.047	15	20	+/- .005
0135	.060	15	20	+/- .005

Part No.	Thickness (in.)	W (in.)	L (in.)	Tolerance (in.)
0136	.027	17.8	20.5	+/- .005
0137	.030	17.8	20.5	+/- .005
0138	.040	17.8	20.5	+/- .005
0139	.047	17.8	20.5	+/- .005
0140	.060	17.8	20.5	+/- .005
0141	.020	10	20	+/- .004
0142	.027	10	20	+/- .004
0143	.030	10	20	+/- .004
0144	.032	10	20	+/- .005
0145	.040	10	20	+/- .005
0146	.047	10	20	+/- .005
0147	.060	10	20	+/- .005
0148	.062	10	20	+/- .005
0149	.093	10	20	+/- .008
0150	.125	10	20	+/- .010
0151	.020	12	18	+/- .004
0152	.027	12	18	+/- .004
0153	.030	12	18	+/- .004
0154	.032	12	18	+/- .005
0155	.040	12	18	+/- .005
0156	.047	12	18	+/- .005
0157	.060	12	18	+/- .005
0158	.062	12	18	+/- .005
0159	.093	12	18	+/- .008
0160	.125	12	18	+/- .010
0161	.032	24	24	+/- .005
0162	.040	24	24	+/- .005
0163	.047	24	24	+/- .006
0164	.062	24	24	+/- .006
0165	.093	24	24	+/- .008
0166	0.118	24	24	+/- .010
0167	0.125	24	24	+/- .010
0168	0.156	24	24	+/- .010
0169	0.188	24	24	+/- .010

Please call application assistance for other sheet sizes available.

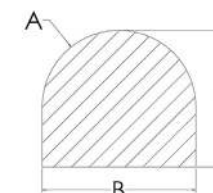
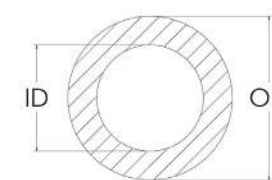
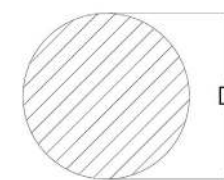

**SOLID ROUND EXTRUSION**

Part No.	D (in.)	M83528 Dash
0201	.040	1/001
0202	.053	1/002
0203	.062	1/003
0204	.070	1/004
0212	.080	1/005
0205	.093	1/006
0206	.103	1/007
0213	.112	N/A
0207	.119	1/008
0208	.125	1/009
0214	.130	N/A
0209	.139	1/010
0215	.150	N/A
0216	.160	N/A
0217	.188	1/011
0210	.216	1/012
0211	.250	1/013

**HOLLOW ROUND EXTRUSION**

Part No.	OD (in.)	ID (in.)	M83528 Dash
0226	.070	.025	N/A
0227	.093	.035	N/A
0228	.103	.040	11/007
0220	.125	.045	11/001
0229	.125	.062	11/006
0221	.156	.050	11/002
0230	.177	.079	11/008
0222	.250	.125	11/003
0223	.312	.192	11/004
0224	.375	.250	11/005
0225	.437	.250	N/A

**D PROFILE SOLID EXTRUSION**

Part No.	A (in.)	B (in.)	C (in.)	M83528 Dash
0410	.031	.055	.064	N/A
0411	.031	.062	.068	3/001
0412	.047	.062	.068	N/A
0413	.047	.094	.078	3/002
0414	.039	.078	.089	3/003
0415	.047	.094	.094	3/004
0416	.031	.062	.100	3/005
0417	.075	.150	.110	3/006
0418	.061	.122	.131	N/A
0419	.061	.124	.136	3/007
0420	.059	.118	.156	3/008
0421	.078	.156	.156	3/009
0422	.089	.178	.175	3/010
0423	.094	.188	.188	3/011
0424	.125	.250	.250	3/012

**SOLID RECTANGULAR EXTRUSION**

Part No.	A (in.)	B (in.)	M83528 Dash
0314	.032	.032	N/A
0301	.063	.042	9/001
0302	.095	.062	9/002
0303	.120	.075	9/003
0304	.125	.062	9/004
0305	.156	.062	9/005
0306	.250	.062	9/006
0307	.500	.075	9/007
0308	.500	.125	9/008
0309	.500	.188	9/009
0310	.750	.062	9/010
0311	.880	.062	9/011
0312	1.00	.250	9/012
0313	1.18	.062	9/013
0315	.060	.080	N/A

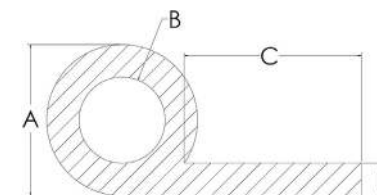

**P PROFILE EXTRUSION**

Part No.	A (in.)	B (in.)	C (in.)	D (in.)	M83528 Dash
0501	.200	.080	.275	.062	N/A
0502	.200	.080	.650	.062	8/001
0503	.250	.125	.250	.062	8/002
0504	.250	.125	.375	.062	8/003
0505	.250	.150	.375	.062	8/004
0506	.250	.125	.625	.062	N/A
0507	.312	.187	.563	.062	8/005
0508	.360	.255	.420	.070	8/006
0509	.200	.080	.275	.062	8/007
0510	.250	.125	.625	.062	8/008

**D PROFILE HOLLOW EXTRUSION**

Part No.	A (in.)	B (in.)	C (in.)	D (in.)	M83528 Dash
0401	.156	.045	.078	.045	N/A
0402	.156	.078	.078	.045	7/001a
0403	.187	.093	.093	.050	7/002a
0404	.250	.125	.125	.065	7/007a
0405	.312	.156	.156	.062	7/003a
0406	.312	.156	.156	.062	7/004b
0408	.487	.080	.244	.080	7/006a
0409	.312	.200	.112	.062	7/005a

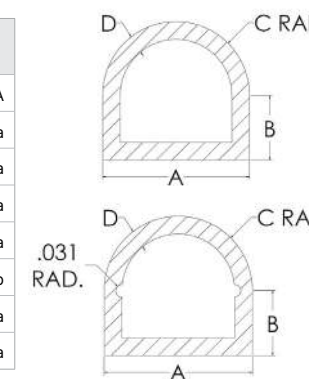

**U PROFILE EXTRUSION**

Part No.	A (in.)	B (in.)	C (in.)	D (in.)	M83528 Dash
0601	.100	.100	.034	.033	10/001
0602	.126	.110	.026	.050	10/002
0603	.126	.225	.020	.075	10/003
0604	.156	.156	.062	.047	10/004
0605	.175	.156	.047	.047	N/A
0606	.175	.156	.047	.075	10/005
0607	.327	.235	.062	.115	10/006

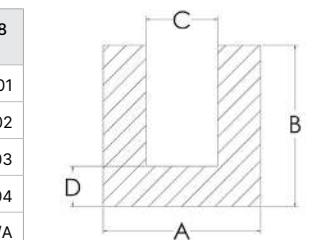



**WAVEGUIDE CONNECTOR GASKETS**

Nolato Jabar manufactures a complete selection of waveguide cover, choke, and contact flange gaskets for pressure and EMI/RFI sealing.

These silver-filled, non-corrosive, particle-filled elastomers can be produced in the configurations shown in the chart below.

The most commonly used waveguide flange requirements are separated into groups for clarification and cross-reference to Nolato Jabar's part number.

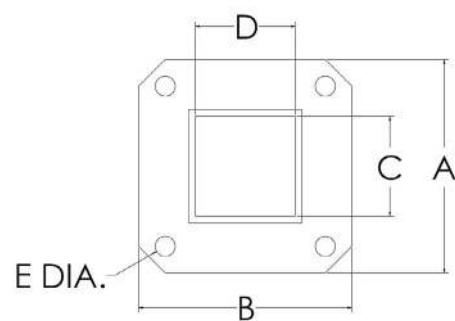

Group I	Group II	Group III Flange	Group IV Description	Group V	Group VI
M83528	EIA SIZE WR	JAN RG-/U	UG	CPR	CMR

**DIE-CUT SQUARE RECTANGULAR WAVEGUIDE CONNECTOR GASKETS. THICKNESS IS .027 IN. +/- .003 IN. UNLESS OTHER IS SPECIFIED AT TIME OF ORDER.**

Part No.	A (in.)	B (in.)	C (in.)	D (in.)	E (in.)	Group I	Group II	Group III	Group IV	Group V	Group VI
2801	1.496	1.796	.760	.385	.155	13/007	75	—	—	—	—
2802	.750	.750	.145	.285	.116	13/001	28	96	599	—	—
2803	.875	.875	.175	.425	.116	13/003	42	53/121	595/97	—	—
2804	1.313	1.313	.630	.320	.140	13/005	62	91/107	419	—	—
2805	1.625	1.625	.905	.405	.169	13/009	90	52/67	39/135	—	—
2806	1.875	1.875	1.130	.505	.180	13/015	112	51/68	51/138	—	—
2807	3.750	5.440	1.710	3.410	.264	13/038	340	112/112	533/54	—	—
2808	4.188	6.344	2.160	4.310	.266	13/040	430	104/105	435/37	—	—
2809	5.438	8.688	3.260	6.510	.250	13/042	650	69/103	417/418	—	—
2810	1.594	2.094	.405	.905	.169	13/010	90	52/67	1736/37	90F	—
2811	1.937	2.687	.633	1.380	.206	13/020	137	50/106	1732/33	137F	—
2812	2.438	3.188	.805	1.600	.257	13/024	159	—	1730/31	159F	—
2813	3.500	2.500	4.880	.880	.266	13/027	187	49/95	1728/29	187F	—
2814	2.750	3.875	1.155	2.300	.270	13/031	229	—	1726/27	229F	—
2815	4.500	3.000	2.850	1.350	.266	13/034	284	48/75	1724/25	284F	—
2816	3.750	5.438	1.710	3.410	.266	13/039	340	112/112	—	340F	—
2817	6.344	4.188	4.310	2.160	.266	13/041	430	104/105	—	430F	—
2818	1.531	2.281	.632	1.382	.150	13/021	137	51/106	—	—	137
2819	1.750	2.500	.800	1.600	.160	13/025	159	—	—	—	159
2820	1.784	2.781	.882	1.882	.156	13/028	187	49/95	—	—	187
2821	2.000	3.156	1.155	2.300	.150	13/032	229	—	—	—	229
2822	3.844	2.344	2.850	1.350	.172	13/035	284	48/75	—	—	284
2823	1.750	2.500	.505	1.130	.171	13/016	—	—	—	—	—
2824	6.344	4.188	4.300	2.150	.147	—	—	—	—	—	—
2825	4.188	6.344	2.150	4.300	.328	—	—	—	—	—	—
2826	3.750	5.438	1.715	.281	.264	—	—	—	—	—	—
2827	2.000	3.156	1.155	3.000	.188	—	—	—	—	—	—
2828	1.875	1.875	1.182	.527	.250	—	—	—	—	—	—
2829	1.875	1.875	1.182	.527	.180	—	—	—	—	—	—

**DIE-CUT CIRCULAR RECTANGULAR WAVEGUIDE CONNECTOR GASKETS**

Part No.	A (in.)	B (in.)	C (in.)	D (in.)	Thick (in.)	Group I	Group II	Group III	Group IV	Group V	Group VI
2831	3.125	.632	1.382	.234	.027	13/019	137	50/106	344/441	—	—
2832	3.625	.882	1.882	.234	.027	13/026	187	49/95	149A/407	—	—
2833	5.312	1.350	2.850	.290	.027	13/033	284	48/75	53/584	—	—

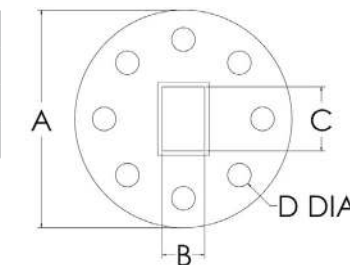

**MOLDED RECTANGULAR / O-CROSS-SECTION WAVEGUIDE CONNECTOR GASKETS**

Part No.	A (in.)	B (in.)	T (in.)	Group I	Group II	Group III	Group IV	Group V
2834	1.368	.868	.103	13/013	90	52/67	1360/61	90-G
2835	1.616	.991	.103	13/018	112	51/68	1494	—
2836	1.866	1.116	.103	13/023	137	50/106	1356/57	137-G
2837	2.449	1.449	.139	13/030	187	49/95	1352/53	187-G
2838	3.451	1.951	.139	13/037	284	48/75	1348/49	284-G

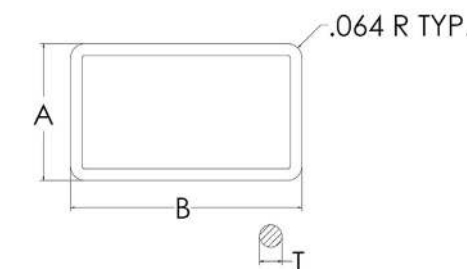

**MOLDED RECTANGULAR WITH D-CROSS-SECTION WAVEGUIDE CONNECTOR GASKETS**

Part No.	A (in.)	B (in.)	C (in.)	D (in.)	Group I
2840	.988	.290	.083	.127	6/001
2841	.988	.490	.083	.127	6/002
2842	3.000	.830	.083	.127	6/003
2843	5.280	1.340	.083	.127	6/004
2844	2.980	1.480	.125	.127	6/005
2845	5.970	1.500	.125	.187	—
2846	3.000	.830	.135	.187	—
2847	3.000	1.273	.135	.187	—
2849	5.280	1.340	.135	.187	—

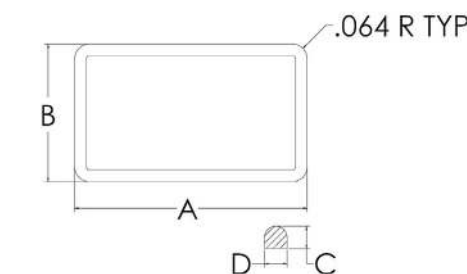

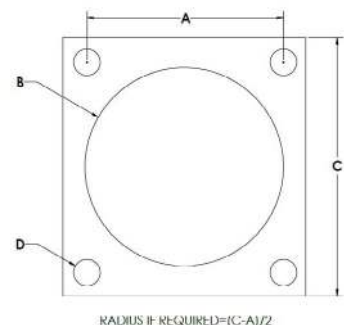

**CONNECTOR GASKETS**

The following table shows the most commonly required connector gaskets for the military and commercial markets. The standard thickness is .032 in. +/- .005 in. To determine your required part number choose the material series (three digit number) from the description found throughout our catalog and add (separated by a hyphen) the four digit part number found below which best fits your dimensional requirements. The most commonly referenced specification for connector gaskets are grouped together below.

Group I	Group II	Group III	Group IV	Group V	Group VI
M83528	JT,PT,PC	MC38999	MC81511	AN	MC83723
85099	MC26482	SERIES	MS90484	MC5015	
	MS3110	I		HT&QWL	
	MS3112	II, IV		MS3100	
	MS3119	III		MS3102	
	MS3120				

Part No.	A (in.)	B (in.)	C (in.)	D (in.)	Group I	Group II	Group III	Group IV	Group V	Group VI
0901	.469	.375	.738	.141	4/001	6	—	—	—	6
0902	.469	.375	.688	.156	—	—	—	—	—	—
0903	.500	.348	.687	.100	—	—	—	—	—	—
0904	.500	.375	.812	.128	—	—	—	—	—	—
0905	.500	.437	.687	.100	—	—	—	—	—	—
0906	.500	.440	.800	.120	—	—	—	—	—	—
0907	.594	.500	.875	.172	—	—	—	—	—	—
0908	.594	.500	.875	.156	4/004	8	—	—	8	8
0909	.594	.531	.875	.120	—	—	—	—	—	—
0910	.594	.568	.812	.125	4/003	—	—	8	—	—
0911	.594	.630	.840	.135	4/002	—	118	—	—	—
0912	.641	.375	.953	.172	—	—	—	—	—	—
0913	.719	.609	.953	.120	—	—	—	—	—	—
0914	.719	.625	1.000	.156	4/007	10	—	—	10	10
0915	.719	.625	.938	.155	—	—	—	—	—	—
0916	.719	.656	1.000	.120	—	—	—	—	—	—
0917	.719	.680	.937	.125	4/006	—	—	10	—	—
0918	.719	.703	1.000	.156	—	—	—	—	—	—
0919	.719	.719	1.031	.130	—	—	—	—	—	—
0920	.719	.750	.965	.135	4/005	19/II10	—	—	—	—
0921	.734	.500	1.047	.172	—	—	—	—	—	—
0922	.750	.875	1.046	.141	—	—	—	—	—	—
0923	.812	.687	1.125	.172	—	—	—	—	—	—
0924	.812	.750	1.125	.156	—	—	—	—	—	—
0925	.812	.781	1.094	.120	—	—	—	—	—	—
0926	.812	.875	1.060	.141	4/008	111/II12	—	—	—	—
0927	.812	.875	1.094	.143	—	—	—	—	—	—
0928	.813	.750	1.031	.156	—	—	—	—	—	—
0929	.813	.750	1.094	.141	4/009	12	—	—	12	12

Part No.	A (in.)	B (in.)	C (in.)	D (in.)	Group I	Group II	Group III	Group IV	Group V	Group VI
0930	.843	1.000	1.156	.141	—	—	—	—	—	—
0931	.906	.750	1.188	.156	—	—	—	—	—	—
0932	.906	.875	1.203	.125	—	—	—	—	—	—
0933	.906	.875	1.188	.156	4/012	14	—	—	14	14
0934	.906	.875	1.125	.156	—	—	—	—	—	—
0935	.906	.906	1.188	.120	—	—	—	—	—	—
0936	.906	.925	1.160	.125	—	—	—	—	—	—
0937	.906	.937	1.265	.140	—	—	—	—	—	—
0938	.906	.938	1.188	.120	—	—	—	—	—	—
0939	.906	.938	1.125	.125	4/011	—	—	14	—	—
0940	.906	.950	1.188	.120	—	—	—	—	—	—
0941	.906	.984	1.188	.125	—	—	—	—	—	—
0942	.906	1.000	1.156	.141	—	—	—	—	—	—
0943	.906	1.005	1.153	.135	4/010	113/II14	—	—	—	—
0944	.938	.781	1.266	.125	—	—	—	—	—	—
0945	.938	.781	1.250	.172	—	—	—	—	—	—
0946	.968	1.187	1.281	.141	—	—	—	—	—	—
0947	.969	.875	1.281	.150	—	—	—	—	—	—
0948	.969	1.000	1.219	.156	—	—	—	—	—	—
0949	.969	1.000	1.281	.156	4/015	16	—	—	16	16
0950	.969	1.000	1.188	.065	—	—	—	—	—	—
0951	.969	1.031	1.281	.120	—	—	—	—	—	—
0952	.969	1.063	1.250	.125	4/014	—	—	16	—	—
0953	.969	1.063	1.250	.188	—	—	—	—	—	—
0954	.969	1.063	1.281	.120	—	—	—	—	—	—
0955	.969	1.135	1.258	.156	4/013	115/II16	—	—	—	—
0956	1.000	1.000	1.406	.177	—	—	—	—	—	—
0957	1.015	1.250	1.406	.141	—	—	—	—	—	—
0958	1.030	.870	1.360	.120	—	—	—	—	—	—
0959	1.031	.875	1.344	.172	—	—	—	—	—	—
0960	1.031	1.000	1.344	.156	—	—	—	—	—	—
0961	1.062	.875	1.500	.177	—	—	—	—	—	—
0962	1.062	1.000	1.375	.166	—	—	—	—	—	—
0963	1.062	1.125	1.406	.149	—	—	—	—	—	—
0964	1.062	1.135	1.375	.156	4/018	18	—	—	18	18
0965	1.062	1.189	1.343	.125	4/017	—	—	18	—	—
0966	1.062	1.260	1.351	.156	4/016	117/II18	—	—	—	—
0967	1.063	1.000	1.375	.128	—	—	—	—	—	—
0968	1.063	1.125	1.375	.203	—	—	—	—	—	—
0969	1.063	1.125	1.312	.156	—	—	—	—	—	—
0970	1.063	1.156	1.375	.120	—	—	—	—	—	—
0971	1.063	1.188	1.375	.120	—	—	—	—	—	—
0972	1.125	1.000	1.500	.188	—	—	—	—	—	—
0973	1.125	1.000	1.438	.172	—	—	—	—	—	—
0974	1.125	1.031	1.500	.173	—	—	—	—	—	—

Part No.	A (in.)	B (in.)	C (in.)	D (in.)	Group I	Group II	Group III	Group IV	Group V	Group VI
0975	1.125	1.062	1.437	.156	—	—	—	—	—	—
0976	1.125	1.125	1.437	.156	—	—	—	—	—	—
0977	1.132	1.312	1.687	.156	—	—	—	—	—	—
0978	1.132	1.439	1.740	.136	—	—	—	—	—	—
0979	1.132	1.560	1.735	.125	—	—	—	—	—	—
0980	1.140	1.437	1.531	.141	—	—	—	—	—	—
0981	1.156	1.140	1.500	.120	—	—	—	—	—	—
0982	1.156	1.219	1.500	.156	—	—	—	—	—	—
0983	1.156	1.250	1.500	.172	4/021	20	—	—	20	20
0984	1.156	1.281	1.469	.156	—	—	—	—	—	—
0985	1.156	1.281	1.500	.120	—	—	—	—	—	—
0986	1.156	1.312	1.467	.125	4/020	—	—	20	—	—
0987	1.156	1.375	1.500	.141	4/019	119/1120	—	—	—	—
0988	1.188	1.344	1.500	.171	—	—	—	—	—	—
0989	1.203	1.125	1.516	.172	—	—	—	—	—	—
0990	1.203	1.156	1.531	.125	—	—	—	—	—	—
0991	1.203	1.250	1.516	.156	—	—	—	—	—	—
0992	1.250	1.312	1.594	.173	—	—	—	—	—	—
0993	1.250	1.375	1.625	.203	—	—	—	—	—	—
0994	1.250	1.375	1.563	.130	—	—	—	—	—	—
0995	1.250	1.375	1.625	.172	4/024	22	—	—	22	22
0996	1.250	1.406	1.625	.120	—	—	—	—	—	—
0997	1.250	1.406	1.594	.141	—	—	—	—	—	—
0998	1.250	1.437	1.625	.120	—	—	—	—	—	—
0999	1.250	1.437	1.562	.125	4/023	—	—	22	—	—
2901	1.250	1.500	1.625	.141	4/022	121/112	—	—	—	—
2902	1.281	1.625	1.750	.141	—	—	—	—	—	—
2903	1.297	1.250	1.672	.172	—	—	—	—	—	—
2904	1.297	1.281	1.750	.173	—	—	—	—	—	—
2905	1.297	1.375	1.672	.125	—	—	—	—	—	—
2906	1.297	1.385	1.688	.150	—	—	—	—	—	—
2907	1.312	1.500	1.750	.125	—	—	—	—	—	—
2908	1.312	1.560	1.812	.125	—	—	—	—	—	—
2909	1.312	1.562	1.750	.140	—	—	—	—	—	—
2910	1.375	1.375	1.750	.172	—	—	—	—	—	—
2911	1.375	1.500	1.750	.188	—	—	—	—	—	—
2912	1.375	1.500	1.750	.203	4/027	24	—	—	24	24
2913	1.375	1.500	1.750	.125	—	—	—	—	—	—
2914	1.375	1.500	1.688	.156	—	—	—	—	—	—
2915	1.375	1.531	1.750	.147	—	—	—	—	—	—
2916	1.375	1.531	1.875	.109	—	—	—	—	—	—
2917	1.375	1.563	1.703	.152	4/026	—	—	24	—	—
2918	1.375	1.625	1.750	.172	4/025	123/1124	—	—	—	—
2919	1.380	1.440	1.800	.204	—	—	—	—	—	—
2920	1.392	1.750	1.843	.172	—	—	—	—	—	—
2921	1.437	1.250	2.000	.257	—	—	—	—	—	—

Part No.	A (in.)	B (in.)	C (in.)	D (in.)	Group I	Group II	Group III	Group IV	Group V	Group VI
2922	1.437	1.437	2.000	.257	—	—	—	—	—	—
2923	1.437	1.567	2.000	.257	—	—	—	—	—	—
2924	1.438	1.594	1.781	.136	—	—	—	—	—	—
2925	1.500	1.500	1.875	.172	—	—	—	—	—	—
2926	1.500	1.625	1.875	.156	—	—	—	—	—	—
2927	1.500	1.750	1.875	.172	4/028	125/IV25	—	—	—	—
2928	1.563	1.750	2.000	.203	4/029	—	—	—	24	—
2929	1.563	1.781	2.000	.188	—	—	—	—	—	—
2930	1.568	2.000	2.171	.172	—	—	—	—	—	—
2931	1.688	1.688	2.125	.195	—	—	—	—	—	—
2932	1.688	2.015	2.281	.219	—	—	—	—	—	—
2933	1.688	2.032	2.375	.125	—	—	—	—	—	—
2934	1.734	2.187	2.356	.203	—	—	—	—	—	—
2935	1.750	1.250	2.500	.312	—	—	—	—	—	—
2936	1.750	1.625	2.500	.312	—	—	—	—	—	—
2937	1.750	1.843	2.250	.219	—	—	—	—	—	—
2938	1.750	2.000	2.250	.219	4/030	—	—	—	28	—
2939	1.750	2.031	2.250	.219	—	—	—	—	—	—
2940	1.852	2.250	2.500	.177	—	—	—	—	—	—
2941	1.188	1.250	1.437	.125	—	—	—	—	—	—
2942	1.188	1.312	1.469	.125	—	—	—	—	—	—
2943	1.938	2.188	2.500	.219	—	—	—	—	—	—
2944	1.938	2.250	2.500	.219	4/031	—	—	—	36	—
2945	1.938	2.281	2.500	.281	—	—	—	—	—	—
2946	1.938	2.281	2.500	.173	—	—	—	—	—	—
2947	2.085	2.515	2.765	.236	—	—	—	—	—	—
2948	2.093	2.188	2.625	.221	—	—	—	—	—	—
2949	2.094	2.531	2.875	.138	—	—	—	—	—	—
2950	2.188	2.438	2.750	.219	—	—	—	—	—	—
2951	2.188	2.500	2.750	.219	4/032	—	—	—	40	—
2952	2.188	2.531	2.750	.173	—	—	—	—	—	—
2953	2.234	2.500	2.781	.166	—	—	—	—	—	—
2954	2.234	2.531	2.750	.173	—	—	—	—	—	—
2955	2.250	2.250	2.690	.201	—	—	—	—	—	—
2956	2.375	2.781	3.000	.219	4/033	—	—	—	44	—
2957	2.475	2.138	3.375	.166	—	—	—	—	—	—
2958	2.500	2.500	2.875	.154	—	—	—	—	—	—
2959	2.531	3.015	3.281	.281	—	—	—	—	—	—
2960	2.531	3.035	3.265	.296	—	—	—	—	—	—
2961	2.625	3.031	3.250	.219	4/034	—	—	—	48	—
2962	3.000	2.000	4.000	.281	—	—	—	—	—	—
2963	3.250	3.125	3.812	.312	—	—	—	—	—	—
2964	3.375	2.938	4.000	.180	—	—	—	—	—	—
2965	3.800	3.000	4.500	.250	—	—	—	—	—	—
2966	3.875	4.000	4.500	.281	—	—	—	—	—	—

Series 000

# Conductive Adhesives

Our conductive particle-filled adhesive sealants are a one-part, electrically conductive, room temperature curing elastomer. This adhesive is supplied as a readily extrudable paste which cures rapidly when exposed to atmospheric moisture. When completely cured the Series 000 Conductive Adhesives are highly resilient elastomers that exhibit superior adhesion to a variety of substrates as well as low volume resistivity.

**FEATURES**

- Electrically conductive
- Thixotropic paste
- Non-corrosive
- Excellent adhesion to various substrates
- One part — no mixing
- Fluorosilicone options available

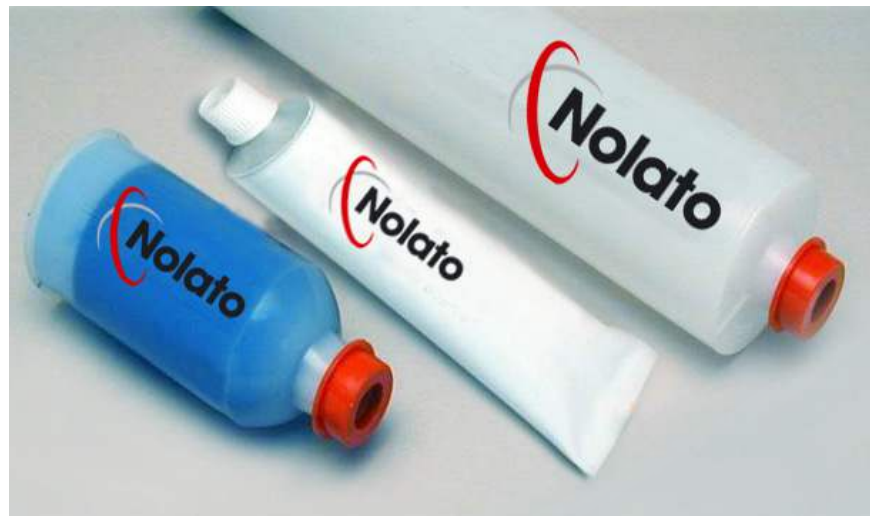

Surfaces to be bonded must be clean, dry and oil free. Apply adhesives directly from their package to the desired area. If this product will be used as a sealant, it should be applied liberally to the interface. It is important to force adhesives into the material being bonded as much as possible. If maximum adhesion and RFI shielding are desired, apply weight to the sealed interface during cure. An appropriate primer is also available for difficult bonding substrates.

**PART NUMBERING**

**CONDUCTIVE PARTICLE**

- 20 = Nickel Graphite
- 30 = Silver Glass
- 40 = Silver Nickel
- 50 = Silver Aluminum
- 60 = Silver Copper
- 80 = Pure Silver

OXX-XXXX

**FLUID OUNCES**

- 1100 = .5 fl. oz. (metal tube)
- 1200 = 1.0 fl. oz. (metal tube or cartridge)
- 1300 = 2.5 fl. oz. (cartridge)
- 1400 = 10.3 fl. oz. (cartridge)

**TYPICAL PROPERTIES**

	020 Nickel Graphite	030 Silver Glass	040 Silver Nickel	050 Silver Aluminum	060 Silver Copper	080 Pure Silver
Specific Gravity	2.29	1.82	3.58	1.86	3.58	4.20
Consistency	thick paste	thick paste	thick paste	thick paste	thick paste	thick paste
Lap Shear Strength Minimum (PSI)	150	120	120	175	200	225
Operating Temp. Range (°F)	-55 /+400	-55 /+400	-55 /+400	-55 /+400	-55 /+400	-55 /+400
Skin Over (MIN)	15	15	15	15	15	15
Tack Free (MIN)	90	90	90	90	90	90
Cure for Handling (HRS)	12 – 24	12 – 24	12 – 24	12 – 24	12 – 24	12 – 24
Full Cure (HRS)	72 – 144	72 – 144	72 – 144	72 – 144	72 – 144	72 – 144
Color	Dark Grey	Light Tan	Tan	Blue	Dark Tan	Tan
Durometer Shore A	65	70	75	68	70	65
Tensile Strength PSI (MIN)	540	415	285	260	285	280
Elongation % (MIN)	210	100	150	155	150	165
Tear Strength #/IN (MIN)	90	52	50	45	50	54
Volume Resistivity OHM-CM	.06	.01	.008	.01	.008	.005

**SAFETY AND HANDLING INFORMATION**

**Warning:** Contact with adhesives is irritating to skin and eyes. If contact is made with the skin the excess should be wiped off with a dry cloth or paper towel followed by a waterless hand cleaner such as the type used to clean grease or oil from the skin. For specific information regarding safety and handling of this product refer to the Safety Data Sheet.

**Storage Information:** Shelf life of adhesives are one (1) year from date of shipment provided the products are stored in the dry, tightly sealed, original container below 23°C (73.4°F).



Series 900

# Expanded Metal/Cloth Elastomer

**DESCRIPTION**

Expanded metal/cloth elastomer is a composite of metal sheeting impregnated with an elastomer to yield a highly conductive yet resilient gasket material for EMI/RFI shielding as well as a pressure and environmental seal. This fabrication process allows for consistency in quality and performance. It is available without elastomer filler for use in applications where an environmental seal is not necessary, or for use in applications as a low performance RF air filter.

**APPLICATION**

Designed for specific applications where joint unevenness does not exceed .004 in. and/or where space restrictions occur. Conductivity is achieved on contact due to the protruding contact points, which lends to its use in nearly all types of flat connectors.

**PART NUMBERING**

**ELASTOMER**

- 0 = None
- 1 = Silicone CL2 GR50
- 2 = Silicone 3302D
- 3 = Synthetic AMS 3222C
- 4 = Fluorosilicone
- 5 = Low Out Gassing Silicone

9XX-XXXX

part number from table

**METAL TYPE**

- 1 = Expanded Monel
- 2 = Expanded Aluminum
- 3 = Expanded Copper
- 4 = Expanded Nickel
- 5 = Expanded Stainless Steel
- 6 = Woven Aluminum Screen Cloth

- 0 = Standard
- 1 = Custom

**STANDARD SHEETING 50 FT ROLLS**

Part No.	Thickness (+/- .004 in.)	Width (minimum)
0101	.016	8.0
0102	.016	10.0
0103	.016	12.0
0104	.020	8.0
0105	.020	10.0
0106	.020	12.0
0107	.030	8.0
0108	.030	10.0
0109	.030	12.0

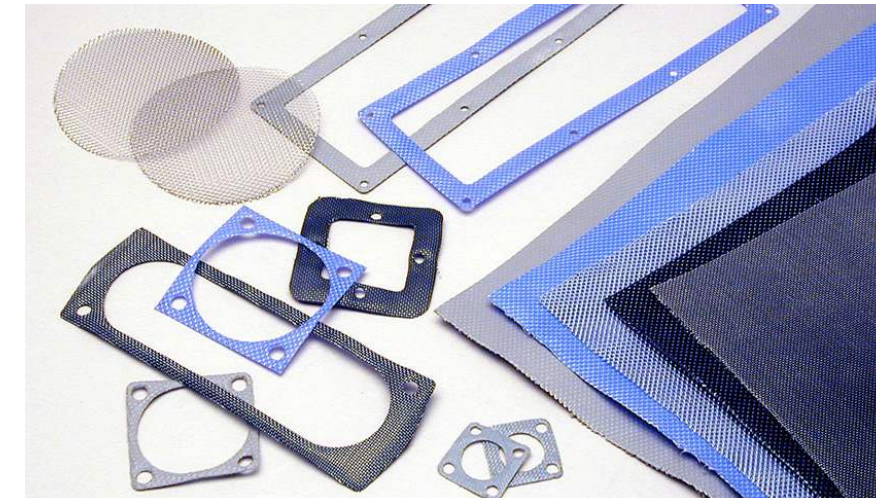

**SPECIFICATIONS**

Listed are standard available mesh and elastomer types. Others are available upon request.

**AVAILABLE ELASTOMERS**

Part No.	Elastomer	Specification
0	None	Unfilled
1	Silicone	CL2 GR50
2	Silicone	AMS 3302
3	Synthetic	AMS 3222
4	Fluorosilicone	MIL-R-25988

**AVAILABLE METALS**

Part No.	Metal	Specification
1	Expanded Monel	QQ-N-281
2	Expanded Aluminum	QQ-A-250
3	Expanded Copper	N/A
4	Expanded Nickel	N/A
5	Expanded Stainless Steel	Alloy 302
6	Woven Aluminum Screen Cloth 28 Mesh	AMS 4182

**TYPICAL SHIELDING PERFORMANCE CHARACTERISTICS**

	901	902	903	926 / 936
Shielding db: 200 KHz	60	60	70	65
Shielding db: 100 MHz	90	90	100	90
Shielding db: 1.0 GHz	70	70	85	75
EMP (Survivability)	yes	yes	yes	yes
Closing Force (PSI)	50-75	50-75	50-75	50-75
Compression Set @ 50 PSI	1%	1%	1%	1%



Conductive Seals

# Specialty Shielding

## Reinforced Conductive Seals

**DESCRIPTION**

Standard conductive particle-filled elastomers often do not have the inherent strength required for demanding hatch, access panel, and door seal applications. The strength can be greatly increased by the addition of a reinforcing fabric such as Dacron or fiberglass. The fabric can be embedded into the seal so environmental sealing and shielding effectiveness remain unaffected.

**APPLICATION**

Reinforced, electrically conductive seals are most often used in applications where there is high vibration (which can wear down a gasket's resilience) and where closing forces create shear forces too high for standard gaskets to withstand.

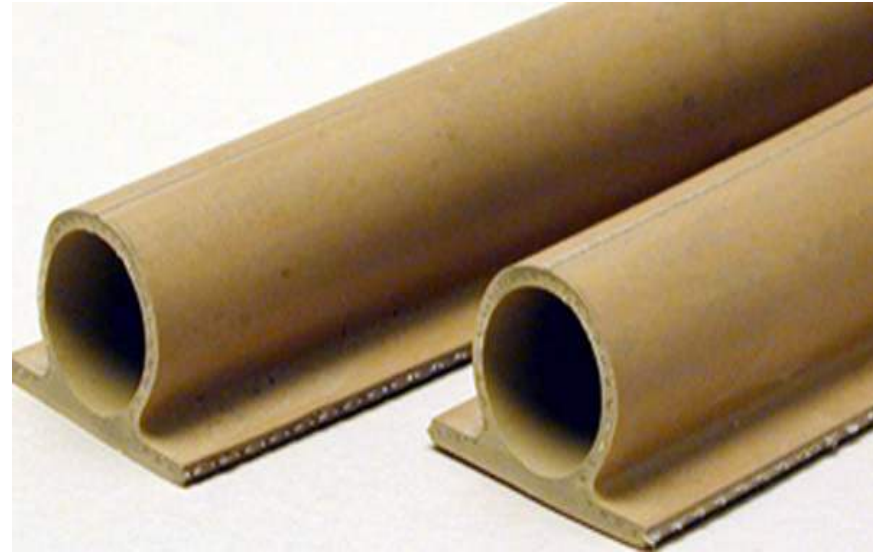

**SPECIFICATIONS**

These reinforced electrically conductive seals are manufactured with the same military grade compounds as our non-reinforced materials and are certified to meet Mil-DTL-83528 where applicable.

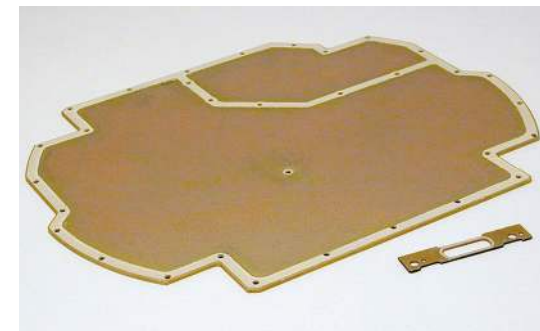

## Mold-in-Place Conductive Seals

**DESCRIPTION**

Certain applications require the technology of molding the conductive gasket directly to an access panel or housing. This manufacturing technique permits the use of much smaller and tighter toleranced cross-sections while eliminating the need for machined grooves or mounting adhesives. The same compounds depicted in the 800 Series Conductive Particle Elastomer section can be specified for this direct molding operation.

## Co-Molded Conductive Seals

**DESCRIPTION**

We are able to co-mold our 800 series conductive materials with a variety of non-conductive materials in order to meet the combined needs of EMI shielding, mechanical sealing, and galvanic compatibility required in many applications. This combination of materials creates environmental sealing as well as corrosion resistance.

