

P.C.B. HOLE DRILLINGS

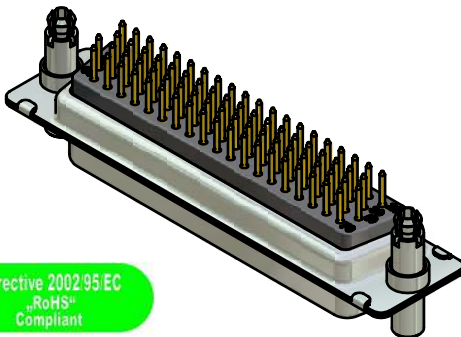
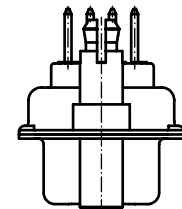
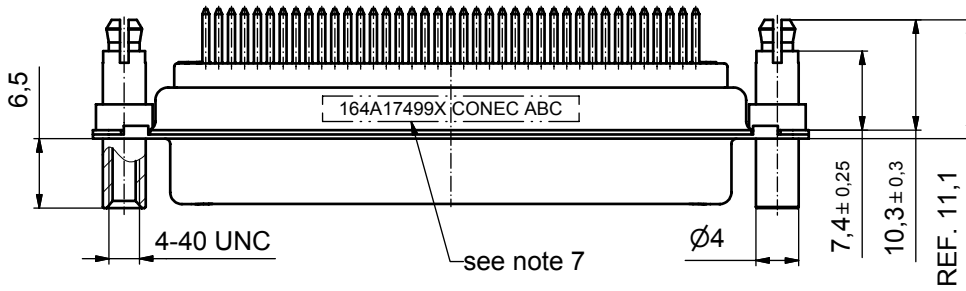
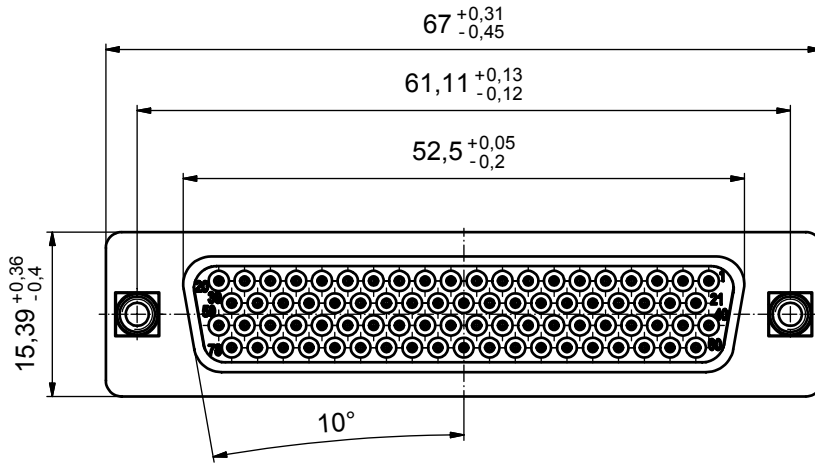
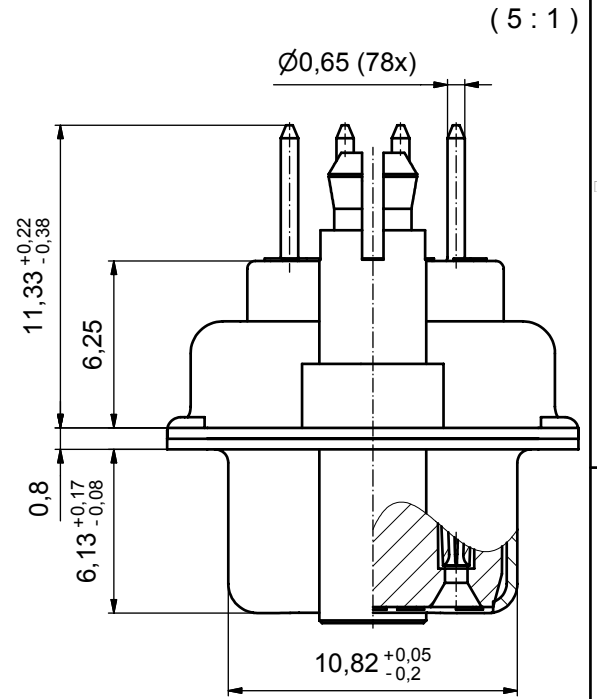

Directive 2002/95/EC
 "RoHS"
 Compliant

NOTES:

- METALSHELLS: STEEL; min. 315µin TIN over 40-80µin NICKEL
- INSULATORS: PBT GF UL 94 V-0; BLACK
- CONTACTS: COPPER ALLOY
 PLATING: 8µin HARD GOLD over min. 50µin NICKEL
- THREADED LOCKS AND SPACER CLIPS: COPPER ALLOY; min. 200µin TIN over 80µin NICKEL
 PCB-HOLE: Ø3.2±0,1; PCB THICKNESS 1,6mm
- COLLARS: COPPER ALLOY; min. 200µin TIN over 80µin NICKEL
- MAXIMUM TORQUE VALUE FOR THREAD: 6 in.LB
- CONNECTOR IS PART MARKED: 164A17499X CONEC ABC

APPROVAL # FREIGABE # DEBLOCAGE # AUTORIZACION # APPROVAL	
CUSTOMER APPROVAL DATE:	
NAME:	TITLE:
COMPANY NAME:	
APPROVAL # FREIGABE # DEBLOCAGE # AUTORIZACION # APPROVAL	

THIS DRAWING MAY NOT BE COPIED OR REPRODUCED IN ANY WAY, AND MAY NOT BE PASSED ON TO A THIRD PARTY WITHOUT WRITTEN PERMISSION. OWNERSHIP AND COPYRIGHT OF CONEC GmbH			
DO NOT ALTER CAD DRAWING BY HAND			
rev.	description	date	name
a	Origin		

tolerance	dim. in mm
date	name
drawn	28.05.09 Schmidt
appd.	28.05.09 Fischer
norm	
d-old	

scale:	2:1 (5:1)	
material:	see notes	
title:		
D-SUB HD FEMALE		
78pos. SOLDER PIN STRAIGHT		
with threaded lock and spacer clip		
dwg no:	Inventor 10	DIN-A3
16K2A2412		sh: 1
part no:	164A17499X	

