

THIS DRAWING IS UNPUBLISHED. RELEASED FOR PUBLICATION
 © COPYRIGHT - L ALL RIGHTS RESERVED.

REVISIONS				
P	LTR	DESCRIPTION	DATE	APVD
L		REVISED PER ECO-18-007013	21MAY2018	KH MZ

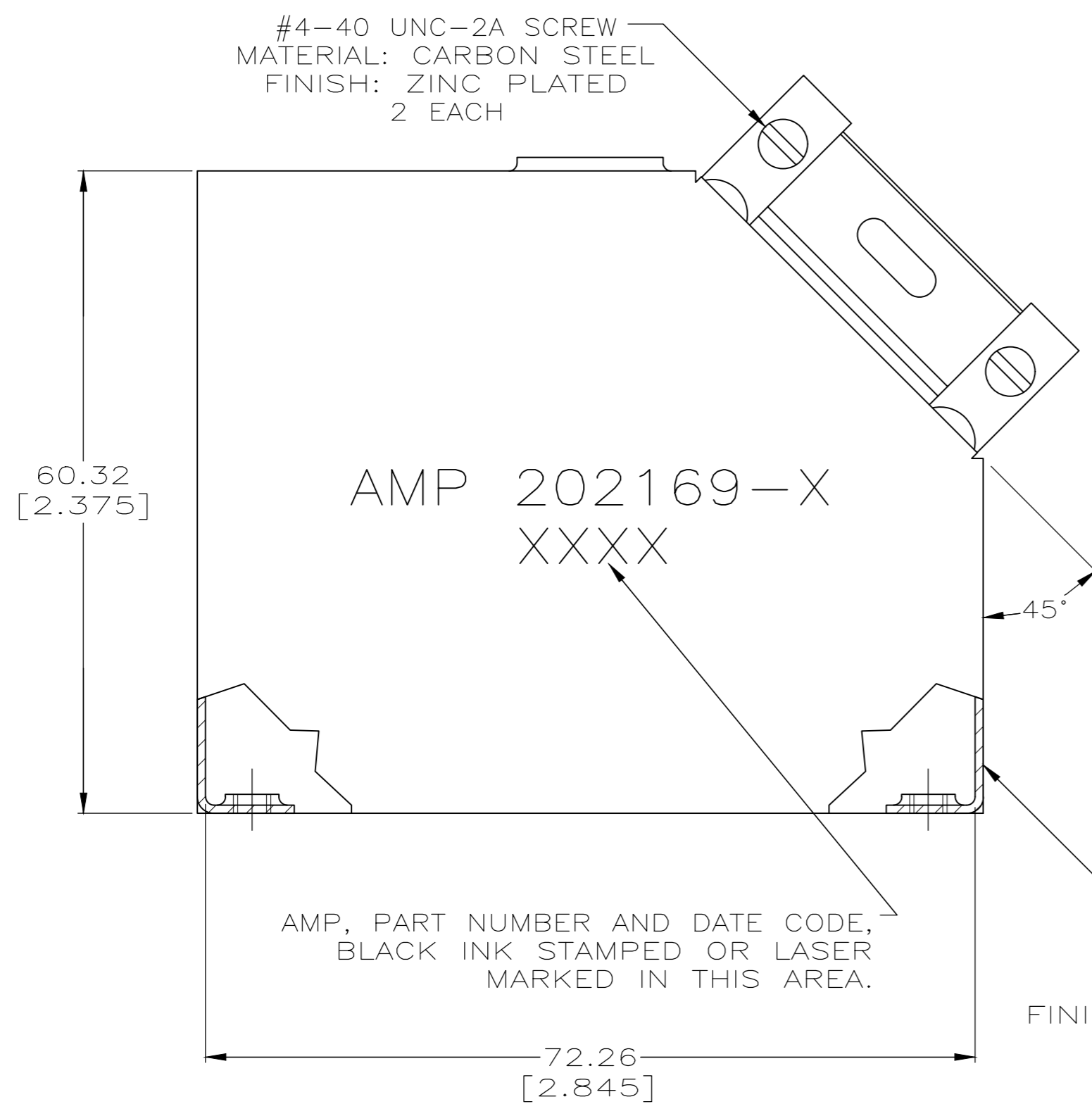

FIXED CABLE CLAMP
 MATERIAL: STAINLESS STEEL
 1 EACH

RIVET
 MATERIAL: STEEL
 FINISH: NICKEL PLATED
 2 EACH

SHIELDS
 MATERIAL: CARBON STEEL
 FINISH: 5.08um [.000200] MIN NICKEL
 2 EACH

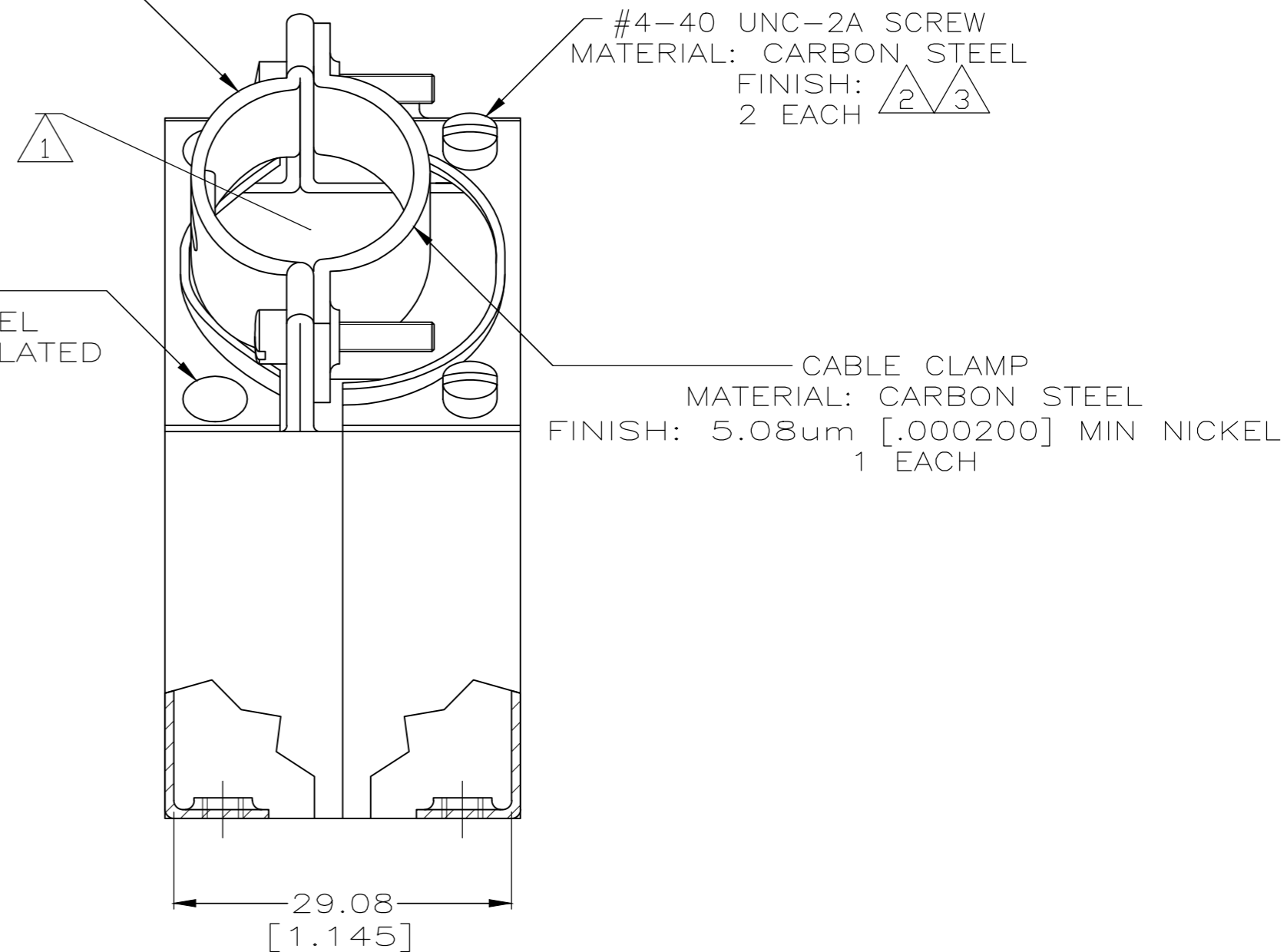

$\triangle 3$	202169-4
$\triangle 2$	202169-1
SCREW FINISH	PART NUMBER

- $\triangle 1$ ACCOMMODATES 22.86-25.40[.900-1.000] DIAMETER CABLE.
- $\triangle 2$ FINISH: ZINC WITH HEXAVALENT CHROMATE.
- $\triangle 3$ FINISH: ZINC WITH NON-HEXAVALENT CHROMATE.

THIS DRAWING IS A CONTROLLED DOCUMENT.		DWN D.HARDY 10-25-94	TE Connectivity Ltd.	
DIMENSIONS: mm [INCHES]		CHK R.STONE 10-27-94	NAME SHIELD KIT, UNASSEMBLED, 104 POSITION, M SERIES	
TOLERANCES UNLESS OTHERWISE SPECIFIED: 0 PLC ± - 1 PLC ± - 2 PLC ± 0.38 [.015] 3 PLC ± - 4 PLC ± - ANGLES ± -		APVD -	PRODUCT SPEC -	
MATERIAL SEE CALLOUTS		FINISH SEE CALLOUTS	APPLICATION SPEC -	RESTRICTED TO -
WEIGHT 0		SCALE 2:1	SIZE A2	CAGE CODE 00779
CUSTOMER DRAWING		DRAWING NO C=202169	SHEET 1 of 1	