

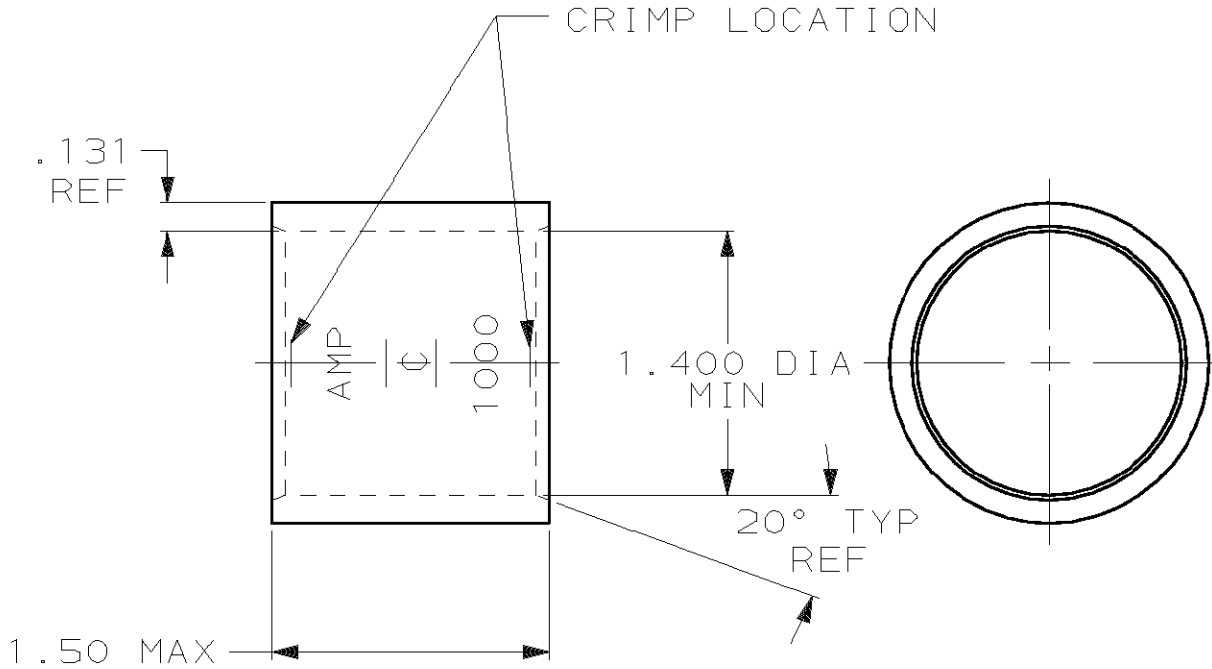

LOC G	DIST 86	P	F	REVISIONS		
		LTR		DESCRIPTION	DATE	APPROVED
		F		REV PER OG3A-0637-01	030CT02	JR/MS

1 PREPRODUCTION - FASR REQ



THIS DRAWING IS UNPUBLISHED. RELEASED FOR PUBLICATION. BY AMP INCORPORATED. ALL INTERNATIONAL RIGHTS RESERVED. © COPYRIGHT 19

950-1,125 MCM	CLEANED, UNPLATED	1-324456-0
	TIN PL PER ASTM B545 .000150 MIN THK	324456
RANGE	FINISH	PART NO

DO NOT SCALE PRINT. UNLESS SPECIFIED DIMENSIONS IN INCHES TOLERANCES ON: 2 PLC DEC ± - 3 PLC DEC ± - ANGLES ± -	DR 1/16/89 P FORTNEY	AMP INCORPORATED Harrisburg, Pa. 17105	
	CHK 6/20/89 MS FEHER		
MATERIAL COPPER ASTM-B-75 ANNEALED	APPD 6/20/89 WJ VOCKROTH	NAME WIRE SPLICE, PARALLEL, AMPOWER, WIRE SIZE: 1000 MCM	
	APPD 6/20/89 R ADAMS	SIZE <b>A</b>	FSCM NO 00779
FINISH SEE TABLE	PRODUCT SPEC -	DRAWING NO 324456	
	APPLICATION SPEC -	SCALE 1:1	SHEET 1 OF 1
	WEIGHT .305 LB.		

