

This document is the property of Amphenol Corporation and is delivered on the express condition that it is not to be disclosed, reproduced or used, in whole or in part, for manufacture or sale by anyone other than Amphenol Corporation without its prior consent, and that no right is granted to disclose or to use any information in this document.

The marking on this product doesn't contain environmental hazardous materials per Material Specification SS-00259 for Sony GP compliant or per directive 2011/65/EU for RoHS compliant.



ORIGINAL



REVISIONS				
SYM	ECN No.	DESCRIPTION	DATE	APPROVED
A		UNRELEASE FOR RoHS	06/08/2011	Arron Lin
B	NE-12109	UPDATE DRAWING	08/17/2012	Arron Lin
C	NE-14117	UPDATE NOTE	06/18/2014	Arron Lin

NOTES:

- MATERIAL:
HOUSING: HIGH TEMPERATURE THERMAL PLASTIC, NY46, UL94V-0, COLOR: OPTION
TERMINAL: COPPER ALLOY.
FITTING NAIL: COPPER ALLOY.
- FINISH:
TERMINAL:
CONTACT AREA: MATTE TIN PLATING 100 μ" THICKNESS MIN.;
SOLDERING AREA: MATTE TIN PLATING 100 μ" THICKNESS MIN.;
UNDER PLATING: NICKEL PLATING 50 μ" THICKNESS MIN. OVERALL
FITTING NAIL:
SOLDERING AREA: MATTE TIN PLATING 100 μ" THICKNESS MIN.;
UNDER PLATING: NICKEL PLATING 50 μ" THICKNESS MIN. OVERALL.
- PACKING IS PER AMTA PACKING SPECIFICATION PKS-0001.

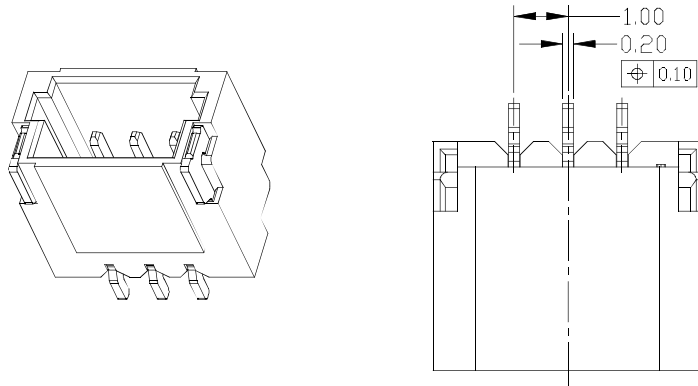

PART NO. G846AXX10XY1EU
NO. OF CIRCUIT — COLOR OF HOUSING
0: NATURAL (WHITE)
1: BLACK

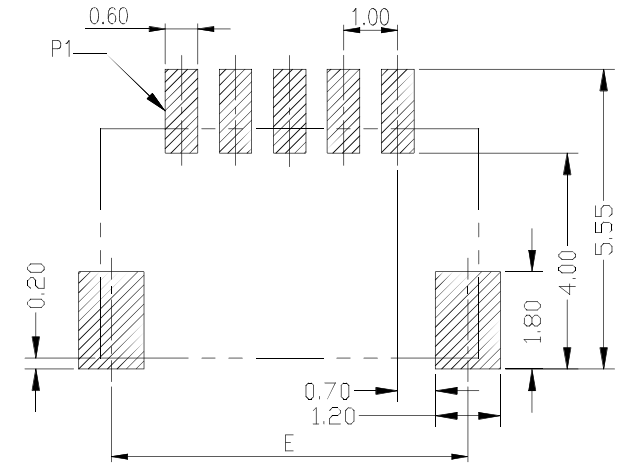
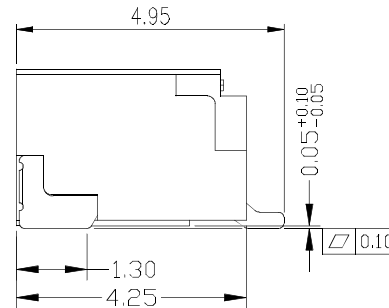
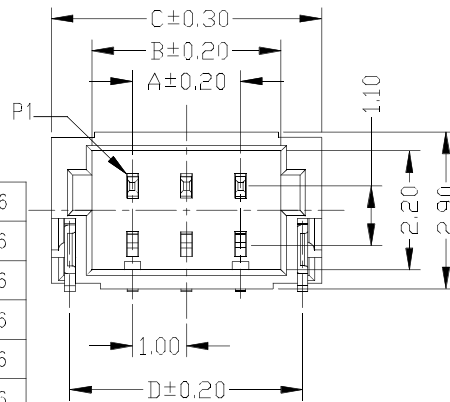

RECOMMENDED PCB LAYOUT
GENERAL TOLERANCE ±0.05

20	19.0	20.5	22.0	21.3	21.6
18	17.0	18.5	20.0	19.3	19.6
15	14.0	15.5	17.0	16.3	16.6
14	13.0	14.5	16.0	15.3	15.6
13	12.0	13.5	15.0	14.3	14.6
12	11.0	12.5	14.0	13.3	13.6
11	10.0	11.5	13.0	12.3	12.6
10	9.0	10.5	12.0	11.3	11.6
9	8.0	9.5	11.0	10.3	10.6
8	7.0	8.5	10.0	9.3	9.6
7	6.0	7.5	9.0	8.3	8.6
6	5.0	6.5	8.0	7.3	7.6
5	4.0	5.5	7.0	6.3	6.6
4	3.0	4.5	6.0	5.3	5.6
3	2.0	3.5	5.0	4.3	4.6
2	1.0	2.5	4.0	3.3	3.6
NO. OF CIRCUIT	A	B	C	D	E

TOLERANCE	APPROVALS	DATE	TITLE		Amphenol®	
X. ±0.30	DRAWN Debby Hung	06/18/2014	WIRE TO BOARD 1.0 MM PITCH CONNECTOR, SMT, R/A TYPE		Amphenol Corporation Amphenol Taiwan Corporation	
X.X ±0.20						
X.XX ±0.10	CHECKED Roger Tsai	06/18/2014				
ANGULAR ±1°	APPROVED Arron Lin	06/18/2014	UNIT mm	SIZE A3	PART No. G846AXX10XY1EU	
UNLESS OTHERWISE SPECIFIED	DWG TYPE CUST DWG	PROJECT CODE BHD	SCALE NA	SHEET 1 OF 1	DWG No. G846AXX10XY1EU	REV. C

This document is the property of Amphenol Corporation and is delivered on the express condition that it is not to be disclosed, reproduced or used, in whole or in part, for manufacture or sale by anyone other than Amphenol Corporation without its prior consent, and that no right is granted to disclose or to use any information in this document.

The marking on this product doesn't contain environmental hazardous materials per Material Specification SS-00259 for Sony GP compliant or per directive 2011/65/EU for RoHS compliant.



ORIGINAL



REVISIONS				
SYM	ECN No.	DESCRIPTION	DATE	APPROVED
A		UNRELEASE FOR RoHS	06/08/2011	Arron Lin
B	NE-12109	UPDATE DRAWING	08/17/2012	Arron Lin
C	NE-14117	UPDATE NOTE	06/18/2014	Arron Lin

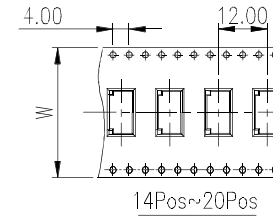
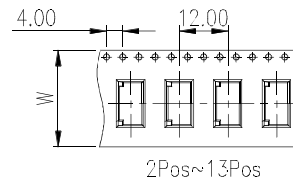
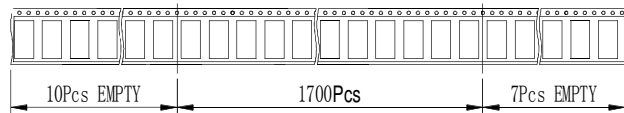
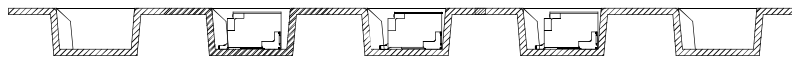
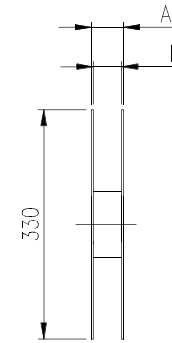
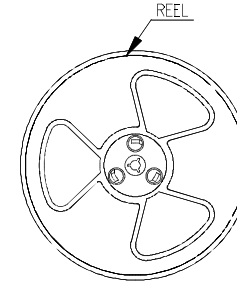
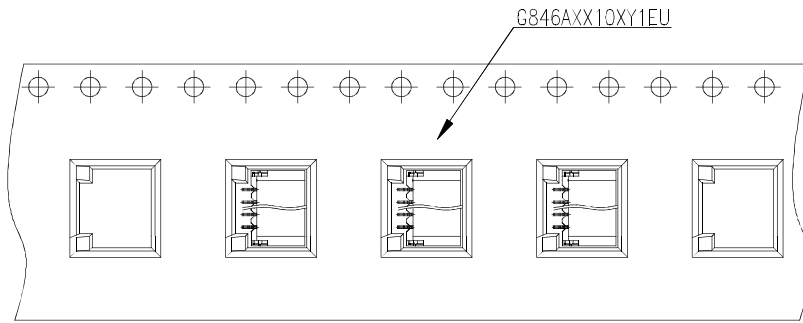

P/N	POS	A	B	W	PCS/Reel	PCS/Carton	Net weight (kg)	Gross weight (kg)
G846A0210XY1EU	02	17.0	12.4	12.0	1700	20400	1.16	7.82
G846A0310XY1EU	03	22.4	16.4	16.0	1700	15300	1.05	6.22
G846A0410XY1EU	04	22.4	16.4	16.0	1700	15300	1.24	6.40
G846A0510XY1EU	05	22.4	16.4	16.0	1700	15300	1.42	6.59
G846A0610XY1EU	06	29.5	24.5	24.0	1700	10200	1.07	4.74
G846A0710XY1EU	07	29.5	24.5	24.0	1700	10200	1.20	4.86
G846A0810XY1EU	08	29.5	24.5	24.0	1700	10200	1.32	4.98
G846A0910XY1EU	09	29.5	24.5	24.0	1700	10200	1.44	5.11
G846A1010XY1EU	10	29.5	24.5	24.0	1700	10200	1.57	5.23
G846A1110XY1EU	11	29.5	24.5	24.0	1700	10200	1.69	5.36
G846A1210XY1EU	12	29.5	24.5	24.0	1700	10200	1.81	5.48
G846A1310XY1EU	13	29.5	24.5	24.0	1700	10200	1.94	5.60
G846A1410XY1EU	14	38.4	32.4	32.0	1700	8500	1.72	4.88
G846A1510XY1EU	15	38.4	32.4	32.0	1700	8500	1.82	4.98
G846A1610XY1EU	16	38.4	32.4	32.0	1700	8500	1.92	5.09
G846A1710XY1EU	17	38.4	32.4	32.0	1700	8500	2.03	5.19
G846A1810XY1EU	18	49.5	44.5	44.0	1700	6800	1.70	4.37
G846A1910XY1EU	19	49.5	44.5	44.0	1700	6800	1.79	4.45
G846A2010XY1EU	20	49.5	44.5	44.0	1700	6800	1.87	4.53

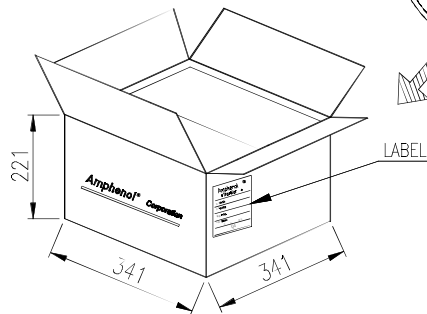
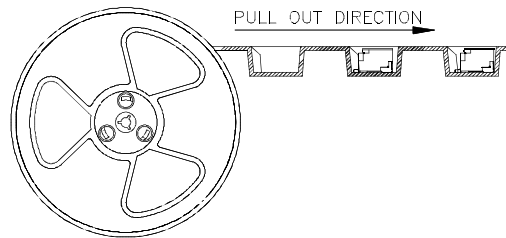
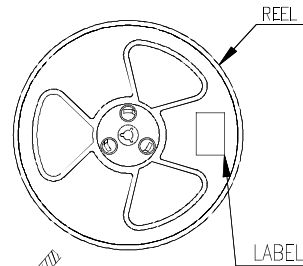

TOLERANCE	APPROVALS	DATE	TITLE
X. ±0.30	DRAWN Debby Hung	06/18/2014	WIRE TO BOARD 1.0 MM PITCH CONNECTOR, SMT, R/A TYPE
X.X ±0.20	CHECKED Roger Tsai	06/18/2014	
X.XX ±0.10	APPROVED Arron Lin	06/18/2014	
ANGULAR ±1°	DWG TYPE CUST DWG	PROJECT CODE BHD	
UNLESS OTHERWISE SPECIFIED			

UNIT		SIZE	PAPT No.
mm	A3	G846AXX10XY1EU	
SCALE		SHEET	DWG No.
NA	1 OF 1	G846AXX10XY1EU	
			REV. C

Amphenol®
Amphenol Corporation
Amphenol Taiwan Corporation