

THIS DRAWING IS UNPUBLISHED. RELEASED FOR PUBLICATION 20
 © COPYRIGHT 20 BY - ALL RIGHTS RESERVED.

LOC	DIST	REVISIONS					
FT	0	P	LTR	DESCRIPTION	DATE	DWN	APVD
		G11		REVISED PER ECO-14-000579	10MAY2014	NK	MM

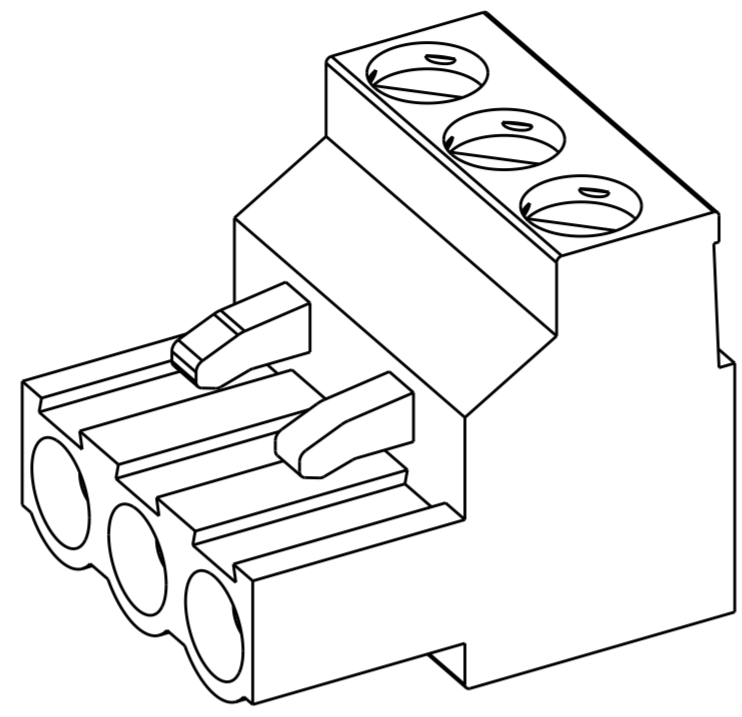

796635-3 AS SHOWN

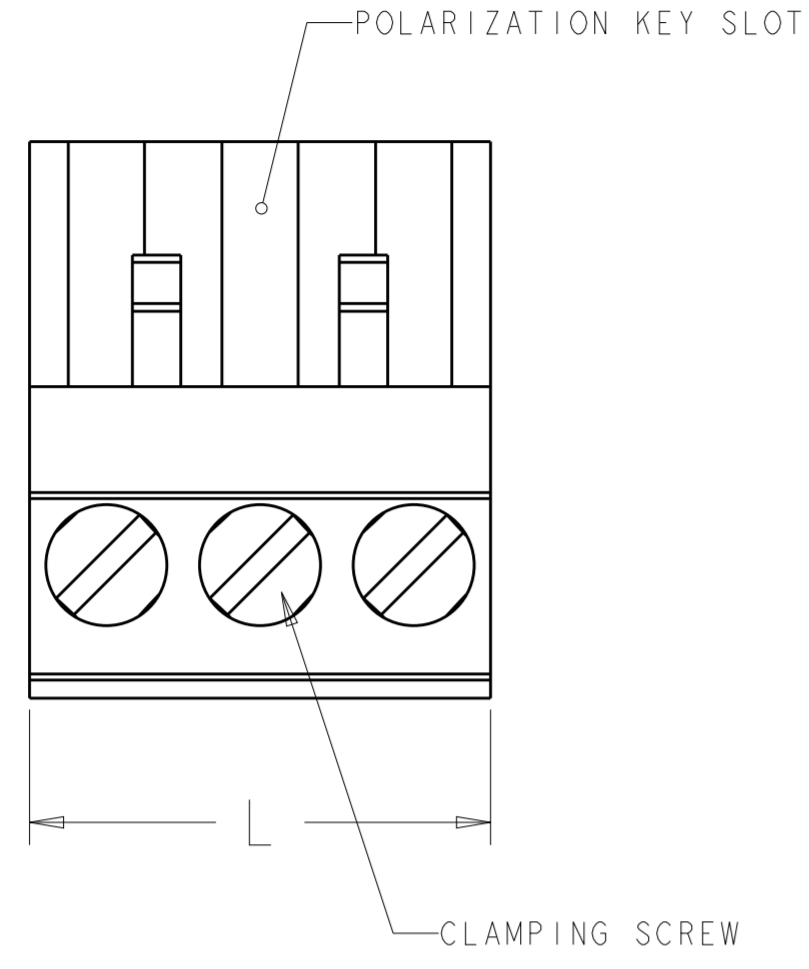
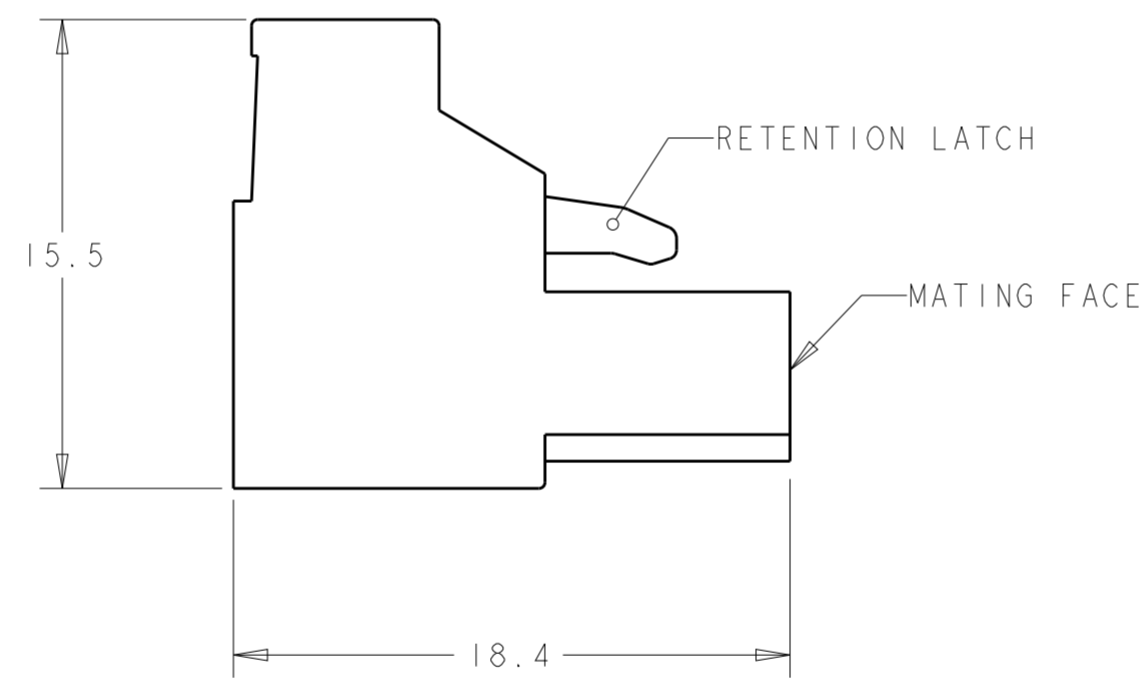
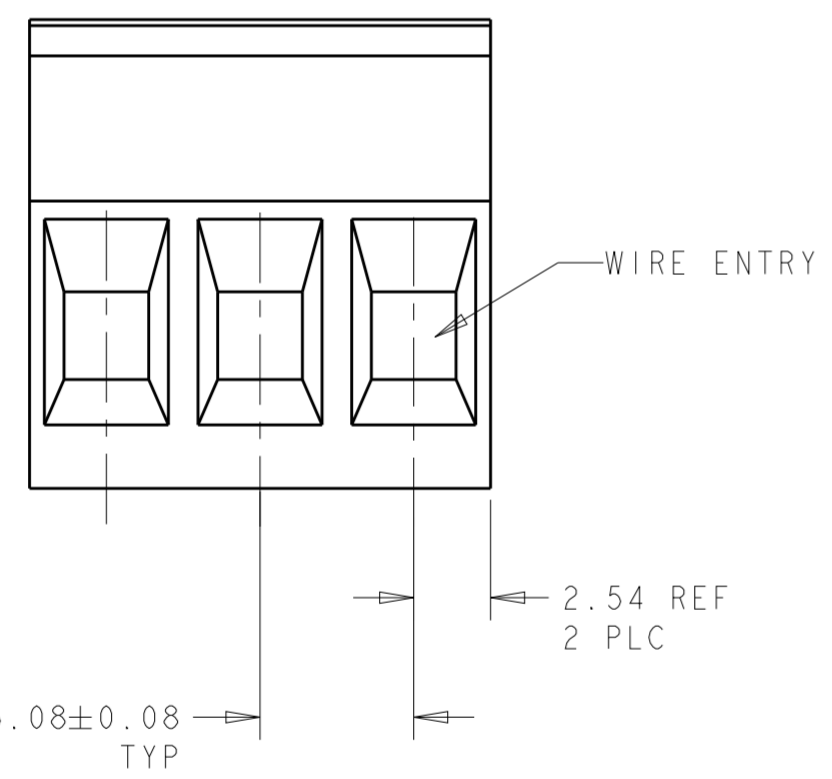

PRELIMINARY	-	0.8µm GOLD	106.68±0.35	21	5-796635-8
PRELIMINARY	-	0.8µm GOLD	86.36±0.30	17	5-796635-7
PRELIMINARY	-	0.8µm GOLD	71.12	14	5-796635-6
PRELIMINARY	-	0.8µm GOLD	60.96	12	5-796635-5
PRELIMINARY	-	0.8µm GOLD	50.80	10	5-796635-4
PRELIMINARY	-	0.8µm GOLD	40.64	8	5-796635-3
PRELIMINARY	-	0.8µm GOLD	35.56	7	5-796635-2
PRELIMINARY	-	0.8µm GOLD	30.48	6	5-796635-1
PRELIMINARY	-	0.8µm GOLD	25.40	5	5-796635-0
PRELIMINARY	-	0.8µm GOLD	20.32±0.15	4	4-796635-9
PRELIMINARY	-	0.8µm GOLD	15.24±0.15	3	4-796635-8
PRELIMINARY	-	0.8µm GOLD	10.16±0.15	2	4-796635-7
DETAIL R	TIN		45.72	9	4-796635-6
DETAIL P	TIN		10.16±0.15	2	4-796635-5
-	0.8µm GOLD		20.32±0.15	4	4-796635-4
-	0.8µm GOLD		45.72	9	4-796635-3
DETAIL N	TIN		86.36±0.30	17	4-796635-2
DETAIL M	TIN		66.04	13	4-796635-1
PRELIMINARY	DETAIL L	TIN	60.96	12	4-796635-0
DETAIL K	TIN		15.24±0.15	3	3-796635-9
DETAIL J	TIN		81.28±0.30	16	3-796635-8
DETAIL H	TIN		15.24±0.15	3	3-796635-7
-	GOLD		30.48±0.20	6	3-796635-6
-	TIN		127.00±0.35	25	2-796635-5
-	TIN		121.92±0.35	24	2-796635-4
-	TIN		116.84±0.35	23	2-796635-3
-	TIN		111.76±0.35	22	2-796635-2
-	TIN		106.68±0.35	21	2-796635-1
-	TIN		101.60±0.35	20	2-796635-0
-	TIN		96.52±0.35	19	1-796635-9
-	TIN		91.44±0.30	18	1-796635-8
-	TIN		86.36±0.30	17	1-796635-7
-	TIN		81.28±0.30	16	1-796635-6
-	TIN		76.20±0.30	15	1-796635-5
-	TIN		71.12	14	1-796635-4
-	TIN		66.04	13	1-796635-3
-	TIN		60.96	12	1-796635-2
-	TIN		55.88	11	1-796635-1
-	TIN		50.80	10	1-796635-0
-	TIN		45.72	9	796635-9
-	TIN		40.64	8	796635-8
-	TIN		35.56±0.20	7	796635-7
-	TIN		30.48±0.20	6	796635-6
-	TIN		25.40±0.20	5	796635-5
-	TIN		20.32±0.15	4	796635-4
-	TIN		15.24±0.15	3	796635-3
-	TIN		10.16±0.15	2	796635-2

MARKING	CONTACT FINISH	L	NO OF POSN	PART NUMBER
---------	----------------	---	------------	-------------

- MATERIALS AND FINISH:
 HOUSING: PA 6-6, UL 94-V0, COLOR:BLACK.
 CLAMP: BRASS, NICKEL PLATED.
 CONTACT SPRING: PHOSPHOR BRONZE, FINISH: SEE TABLE.
 CLAMPING SCREW: M3, BRASS, NICKEL PLATED.
- END-TO-END STACKABLE WITHOUT LOSS OF CENTERLINE SPACING.
- WIRE SIZE RANGE: 12-30 AWG.
- RECOGNIZED UNDER THE COMPONENT PROGRAM OF UNDERWRITERS LABORATORIES INC. FILE N° E60677.
- IMQ CERTIFICATE WITH SURVEILLANCE IN CONFORMITY WITH IEC 998-1/998-2-1.
- INK MARKING, WHITE COLOR.

THIS DRAWING IS A CONTROLLED DOCUMENT.

DWN: S. WELDON 18OCT2000
 CHK: D. BIEVENOUR 18OCT2000
 APVD: D. BIEVENOUR 18OCT2000

STE TE Connectivity

NAME: TERMINAL BLOCK, PLUG, STACKING, 5.08mm PITCH

SIZE: A2 CAGE CODE: 00779 DRAWING NO: C-796635

SCALE: 2:1 SHEET 1 OF 2 REV: G11

THIS DRAWING IS UNPUBLISHED. RELEASED FOR PUBLICATION 20
 © COPYRIGHT 20 BY - ALL RIGHTS RESERVED.

LOC	DIST	REVISIONS					
FT	0	P	LTR	DESCRIPTION	DATE	DWN	APVD
		-		SEE SHEET 1			

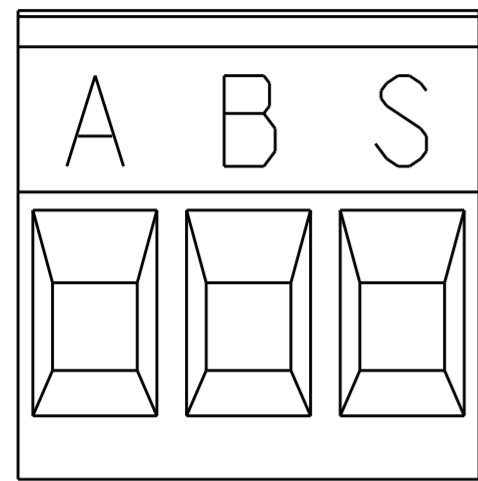

6
DETAIL H

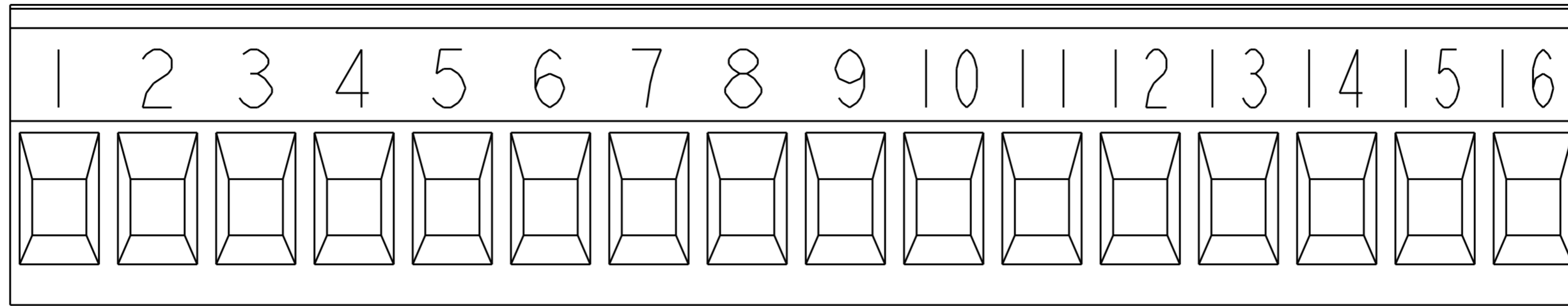

6
DETAIL J

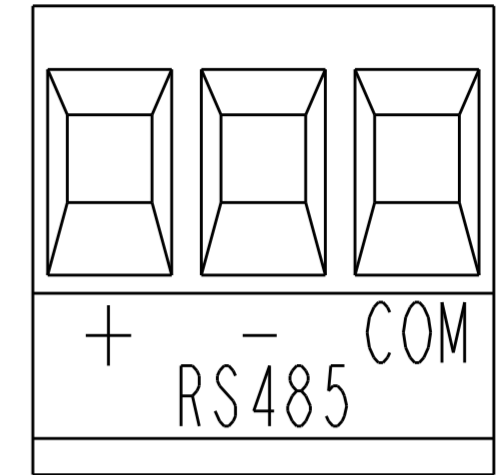

6
DETAIL K

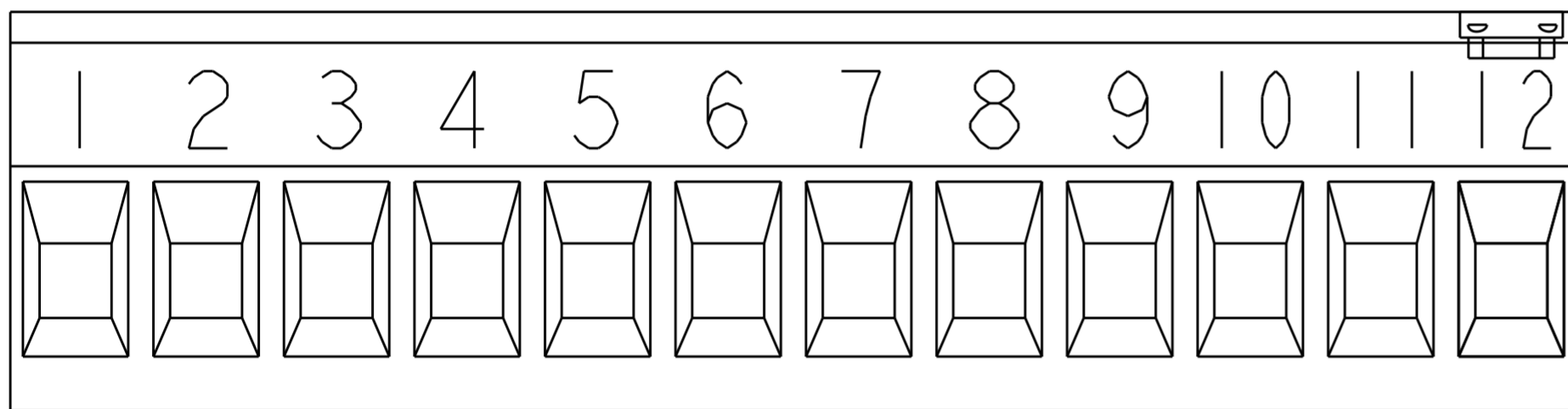

6
DETAIL L

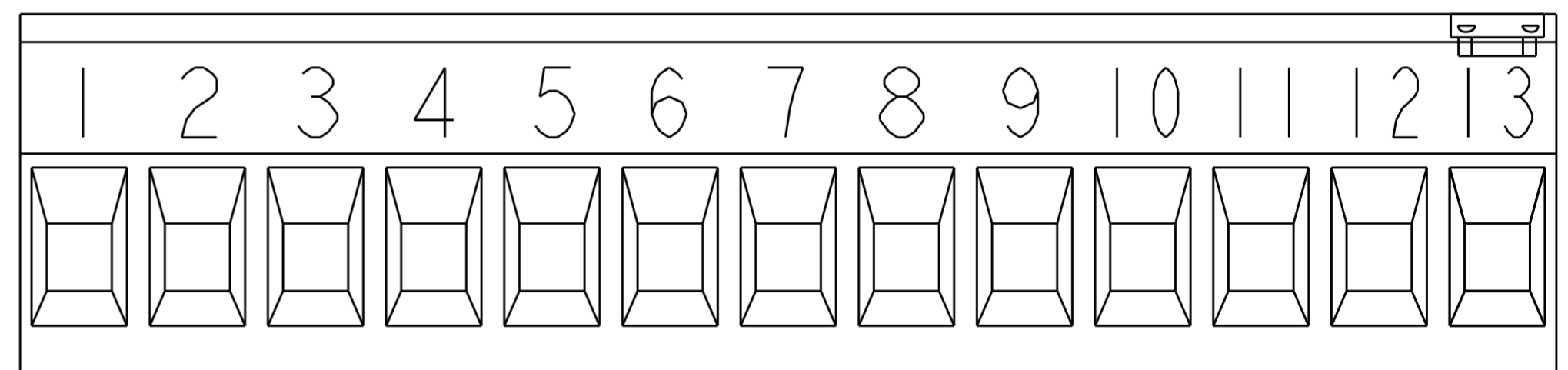

6
DETAIL M

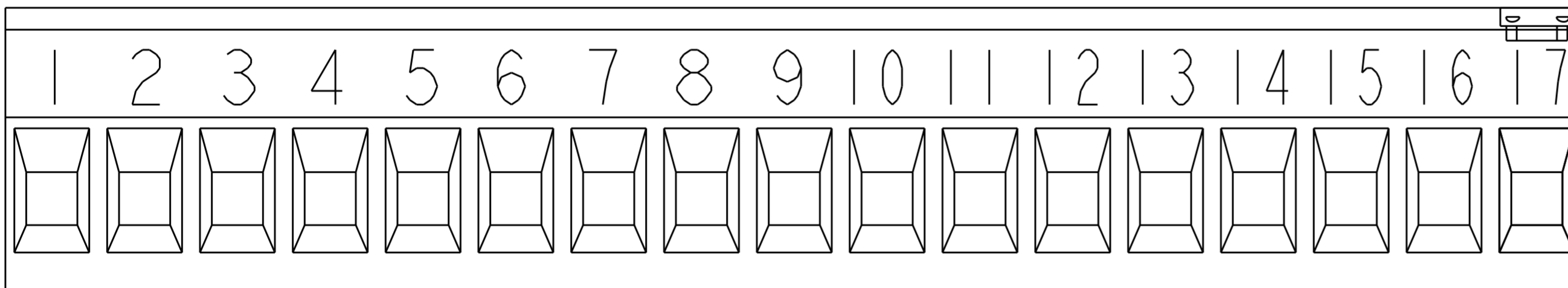

6
DETAIL N

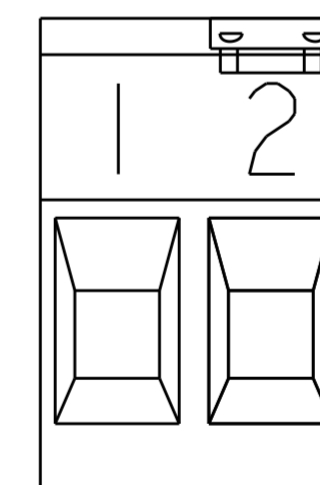

6
DETAIL P

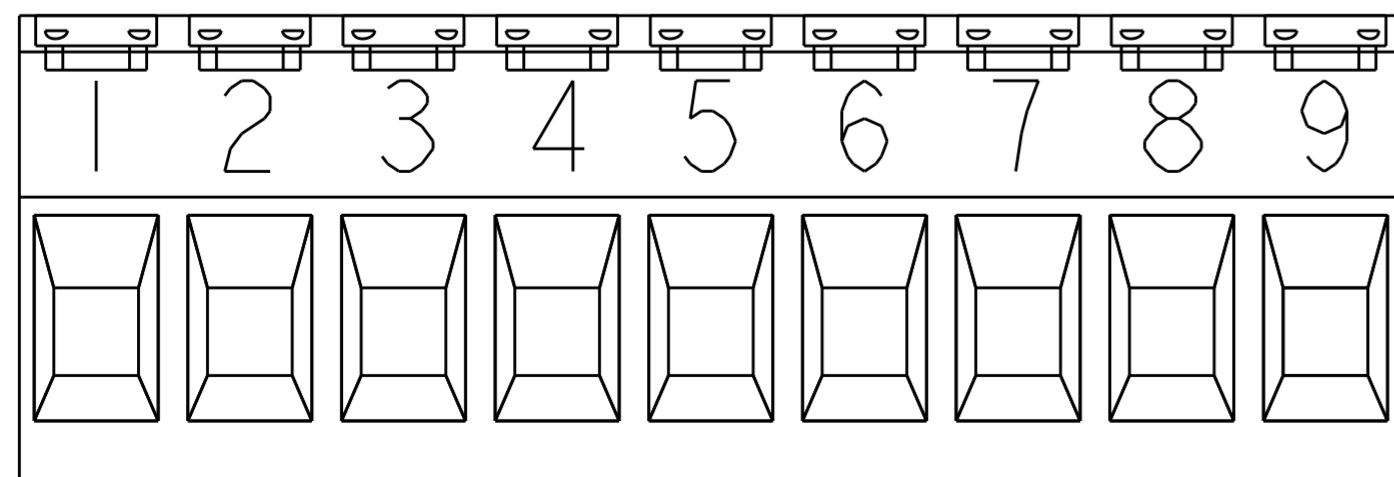

6
DETAIL R

THIS DRAWING IS A CONTROLLED DOCUMENT.		DWN S. WELDON 18OCT2000	 TE Connectivity	NAME TERMINAL BLOCK, PLUG, STACKING, 5.08mm PITCH
DIMENSIONS:		CHK D. BIEVENOUR 18OCT2000		
TOLERANCES UNLESS OTHERWISE SPECIFIED:		APVD D. BIEVENOUR 18OCT2000		
mm		PRODUCT SPEC		
0 PLC ± 1 PLC ±0.2 2 PLC ±0.0 3 PLC ±0.000 4 PLC ±0.0000 ANGLES ±2° FINISH		APPLICATION SPEC	SIZE	RESTRICTED TO
MATERIAL		WEIGHT	A200779	
		CUSTOMER DRAWING	C-796635	
		SCALE 2:1	SHEET 2	OF 2