

**ON Semiconductor®**<http://onsemi.com>

LC87F7DC8A

CMOS IC**FROM 128K byte, RAM 4K byte on-chip**

8-bit 1-chip Microcontroller

Overview

The LC87F7DC8A is an 8-bit microcomputer that, centered around a CPU running at a minimum bus cycle time of 83.3ns, integrates on a single chip a number of hardware features such as 128K-byte flash ROM (onboard programmable), 4K-byte RAM, an on-chip debugger, a LCD controller/driver, sophisticated 16-bit timer/counter (may be divided into 8-bit timers), a 16-bit timer/counter (may be divided into 8-bit timers/counters or 8-bit PWMs), four 8-bit timers with a prescaler, a 16-bit timer with a prescaler (may be divided into 8-bit timers), a base timer serving as a time-of-day clock, a day and time counter, a synchronous SIO interface (with automatic block transmission/reception capabilities), an asynchronous/synchronous SIO interface, two UART ports (full duplex), an 12-bit 15-channel AD converter, two 12-bit PWM channels, a high-speed clock counter, a system clock frequency divider, a small signal detector, two remote control receive functions, and a 31-source 10-vector interrupt feature.

Features

■Flash ROM

- Capable of on-board-programming with wide range, 3.0 to 5.5V, of voltage source.
- Block-erasable in 2-byte units
- 131072 × 8 bits

■RAM

- 4096 × 9 bits

■Minimum Bus Cycle Time

- 83.3ns (12MHz) $V_{DD}=3.0$ to 5.5V
- 125ns (8MHz) $V_{DD}=2.5$ to 5.5V
- 250ns (4MHz) $V_{DD}=2.2$ to 5.5V

Note: The bus cycle time here refers to the ROM read speed.

* This product is licensed from Silicon Storage Technology, Inc. (USA).

LC87F7DC8A

■ Minimum Instruction Cycle Time (tCYC)

- 250ns (12MHz) $V_{DD}=3.0$ to $5.5V$
- 375ns (8MHz) $V_{DD}=2.5$ to $5.5V$
- 750ns (4MHz) $V_{DD}=2.2$ to $5.5V$

■ Ports

- Normal withstand voltage I/O ports
Ports whose I/O direction can be designated in 1 bit units 29 (P0n, P1n, P70 to P73, P8n, XT2)
- Normal withstand voltage input port 1 (XT1)
- LCD ports
 - Segment output 54 (S00 to S53)
 - Common output 4 (COM0 to COM3)
 - Bias terminals for LCD driver 3 (V1 to V3)
- Other functions
 - Input/output ports 54 (P3n, PAn, PBn, PCn, PDn, PEn, PFn,)
 - Input ports 7 (PLn)
- Dedicated oscillator ports 2 (CF1, CF2)
- Reset pin 1 (\overline{RES})
- Power pins 6 (V_{SS1} to V_{SS3} , V_{DD1} to V_{DD3})

■ LCD Controller

- 1) Seven display modes are available (static, 1/2, 1/3, 1/4 duty \times 1/2, 1/3 bias)
- 2) Segment output and common output can be switched to general-purpose input/output ports

■ Small Signal Detection (MIC signals etc)

- 1) Counts pulses with the level which is greater than a preset value
- 2) 2-bit counter

■ Timers

- Timer 0: 16-bit timer/counter with two capture registers.
 - Mode 0: 8-bit timer with an 8-bit programmable prescaler (with two 8-bit capture registers) \times 2 channels
 - Mode 1: 8-bit timer with an 8-bit programmable prescaler (with two 8-bit capture registers) + 8-bit counter (with two 8-bit capture registers)
 - Mode 2: 16-bit timer with an 8-bit programmable prescaler (with two 16-bit capture registers)
 - Mode 3: 16-bit counter (with two 16-bit capture registers)
- Timer 1: 16-bit timer/counter that supports PWM/toggle outputs
 - Mode 0: 8-bit timer with an 8-bit prescaler (with toggle outputs) + 8-bit timer/counter with an 8-bit prescaler (with toggle outputs)
 - Mode 1: 8-bit PWM with an 8-bit prescaler \times 2 channels
 - Mode 2: 16-bit timer/counter with an 8-bit prescaler (with toggle outputs) (toggle outputs also possible from the lower-order 8 bits)
 - Mode 3: 16-bit timer with an 8-bit prescaler (with toggle outputs) (The lower-order 8 bits can be used as PWM.)
- Timer 4: 8-bit timer with a 6-bit prescaler
- Timer 5: 8-bit timer with a 6-bit prescaler
- Timer 6: 8-bit timer with a 6-bit prescaler (with toggle output)
- Timer 7: 8-bit timer with a 6-bit prescaler (with toggle output)
- Timer 8: 16-bit timer
 - Mode 0: 8-bit timer with an 8-bit prescaler \times 2 channels
 - Mode 1: 16-bit timer with an 8-bit prescaler
- Base timer
 - 1) The clock is selectable from the subclock (32.768kHz crystal oscillation), system clock, and timer 0 prescaler output.
 - 2) Interrupts programmable in 5 different time schemes
- Day and time counter
 - 1) Using with a base timer, it can be used as 65000 day + minute + second counter.

■ High-speed Clock Counter

- 1) Can count clocks with a maximum clock rate of 20MHz (at a main clock of 10MHz).
- 2) Can generate output real-time.

■ SIO

- SIO0: 8-bit synchronous serial interface
 - 1) LSB first/MSB first mode selectable
 - 2) Built-in 8-bit baudrate generator (maximum transfer clock cycle = $4/3$ tCYC)
 - 3) Automatic continuous data transmission (1 to 256 bits specifiable in 1-bit units, suspension and resumption of data transmission possible in 1-byte units)
- SIO1: 8-bit asynchronous/synchronous serial interface
 - Mode 0: Synchronous 8-bit serial I/O (2- or 3-wire configuration, 2 to 512 tCYC transfer clocks)
 - Mode 1: Asynchronous serial I/O (half-duplex, 8-data bits, 1-stop bit, 8 to 2048 tCYC baudrates)
 - Mode 2: Bus mode 1 (start bit, 8-data bits, 2 to 512 tCYC transfer clocks)
 - Mode 3: Bus mode 2 (start detect, 8-data bits, stop detect)

■ UART1

- Full duplex
- 7/8/9 bit data bits selectable
- 1 stop bit (2-bit in continuous data transmission)
- Built-in baudrate generator

■ UART2

- Full duplex
- 7/8/9 bit data bits selectable
- 1 stop bit (2-bit in continuous data transmission)
- Built-in baudrate generator

■ AD Converter: 12 bits \times 15 channels

■ PWM: Multi frequency 12-bit PWM \times 2 channels

■ Remote Control Receiver Circuit1

- 1) Noise rejection function
(Units of noise rejection filter: about 120 μ s, when selecting a 32.768kHz crystal oscillator as a clock.)
- 2) Supporting reception formats with a guide-pulse of half-clock/clock/none.
- 3) Determines a end of reception by detecting a no-signal periods (No carrier).
(Supports same reception format with a different bit length.)
- 4) X'tal HOLD mode release function

■ Remote Control Receiver Circuit2

- 1) Noise rejection function
(Units of noise rejection filter: about 120 μ s, when selecting a 32.768kHz crystal oscillator as a clock.)
- 2) Supporting reception formats with a guide-pulse of half-clock/clock/none.
- 3) Determines a end of reception by detecting a no-signal periods (No carrier).
(Supports same reception format with a different bit length.)
- 4) X'tal HOLD mode release function

■ Watchdog Timer

- External RC watchdog timer
- Interrupt and reset signals selectable

■ Clock Output Function

- 1) Able to output selected oscillation clock 1/1, 1/2, 1/4, 1/8, 1/16, 1/32, 1/64 as system clock.
- 2) Able to output oscillation clock of sub clock.

LC87F7DC8A

■ Interrupts

- 31 sources, 10 vector addresses

- 1) Provides three levels (low (L), high (H), and highest (X)) of multiplex interrupt control. Any interrupt requests of the level equal to or lower than the current interrupt are not accepted.
- 2) When interrupt requests to two or more vector addresses occur at the same time, the interrupt of the highest level takes precedence over the other interrupts. For interrupts of the same level, the interrupt into the smallest vector address takes precedence.

No.	Vector Address	Level	Interrupt Source
1	00003H	X or L	INT0
2	0000BH	X or L	INT1
3	00013H	H or L	INT2/T0L/INT4/remote control receiver1
4	0001BH	H or L	INT3/base timer/INT5/remote control receiver2
5	00023H	H or L	T0H/INT6
6	0002BH	H or L	T1L/T1H/INT7
7	00033H	H or L	SIO0/UART1 receive/UART2 receive/T8L/T8H
8	0003BH	H or L	SIO1/UART1 transmit/UART2 transmit
9	00043H	H or L	ADC/MIC/T6/T7/PWM4/PWM5
10	0004BH	H or L	Port 0/T4/T5

- Priority levels $X > H > L$
- Of interrupts of the same level, the one with the smallest vector address takes precedence.

- IFLG (List of interrupt source flag function)

- 1) Shows a list of interrupt source flags that caused a branching to a particular vector address (shown in the diagram above).

■ Subroutine Stack Levels: 2048 levels (The stack is allocated in RAM.)

■ High-speed Multiplication/Division Instructions

- 16 bits \times 8 bits (5 tCYC execution time)
- 24 bits \times 16 bits (12 tCYC execution time)
- 16 bits \div 8 bits (8 tCYC execution time)
- 24 bits \div 16 bits (12 tCYC execution time)

■ Oscillation Circuits

- RC oscillation circuit (internal): For system clock
- CF oscillation circuit: For system clock, with internal Rf
- Crystal oscillation circuit: For low-speed system clock, with internal Rf
- Frequency variable RC oscillation circuit (internal): For system clock
 - 1) Adjustable in $\pm 4\%$ (typ.) step from a selected center frequency.
 - 2) Measures oscillation clock using a input signal from XT1 as a reference.

■ System Clock Divider Function

- Can run on low current.
- The minimum instruction cycle selectable from 300ns, 600ns, 1.2 μ s, 2.4 μ s, 4.8 μ s, 9.6 μ s, 19.2 μ s, 38.4 μ s, and 76.8 μ s (at a main clock rate of 10MHz).

■ Standby Function

- HALT mode: Halts instruction execution while allowing the peripheral circuits to continue operation. (Some parts of the serial transfer function stops operation.)
 - 1) Oscillation is not halted automatically.
 - 2) Canceled by a system reset or occurrence of an interrupt

Continued on next page.

LC87F7DC8A

Continued from preceding page.

- **HOLD mode:** Suspends instruction execution and the operation of the peripheral circuits.
 - 1) The CF, RC, X'tal, and frequency variable RC oscillators automatically stop operation.
 - 2) There are three ways of resetting the HOLD mode.
 - (1) Setting the reset pin to the low level
 - (2) Setting at least one of the INT0, INT1, INT2, INT4, and INT5 pins to the specified level
 - (3) Having an interrupt source established at port 0
- **X'tal HOLD mode:** Suspends instruction execution and the operation of the peripheral circuits except the base timer and the remote control receiver circuit.
 - 1) The CF, RC, and frequency variable RC oscillators automatically stop operation.
 - 2) The state of crystal oscillation established when the X'tal HOLD mode is entered is retained.
 - 3) There are five ways of resetting the X'tal HOLD mode.
 - (1) Setting the reset pin to the low level
 - (2) Setting at least one of the INT0, INT1, INT2, INT4, and INT5 pins to the specified level
 - (3) Having an interrupt source established at port 0
 - (4) Having an interrupt source established in the base timer circuit
 - (5) Having an interrupt source established in the remote control receiver circuit

■ On-chip Debugger

- Supports software debugging with the IC mounted on the target board.

■ Package Form

- QIP100E(14×20): Lead-free type
- TQFP100(14×14): Lead-free type/Halogen-free type

■ Development Tools

- On-chip debugger: TCB87-TypeB + LC87F7DC8A

■ Flash ROM Programming Boards

Package	Programming boards
QIP100E(14×20)	W87FQ100
TQFP100(14×14)	W87FSQ100

■ Flash ROM Programmer

Maker		Model	Supported version	Device
Flash Support Group, Inc. (FSG)	Single	AF9708 AF9709/AF9709B/AF9709C (Including product of Ando Electric Co., Ltd)	(Note 2)	LC87F7DC8A
	Gang	AF9723/AF9723B(Main body) (Including product of Ando Electric Co., Ltd)	(Note 2)	LC87F7DC8A
AF9833(Unit) (Including product of Ando Electric Co., Ltd)		(Note 2)		
Flash Support Group, Inc. (FSG) + Our company (Note 1)	Onboard Single/Gang	AF9101/AF9103(Main body) (FSG)	(Note 2)	LC87F7DC8A
		SIB87(interface driver) (Our company model)		
Our company	Single/Gang	SKK/SKK Type B (SANYO FWS)	Application Version After 1.04 Chip Data Version After 2.16	LC87F7DC8A
	Onboard Single/Gang	SKK-DBG Type B (SANYO FWS)		

Note 1: With the FSG onboard programmer (AF9101/AF9103) and the serial interface driver provided by Our company, PC-less standalone onboard programming is possible

Note 2: Depending on programming conditions, it is necessary to use a dedicated programming device and a program. Please contact Our company or FSG if you have any questions or difficulties regarding this matter.

Package Dimensions

unit : mm (typ)

3151A

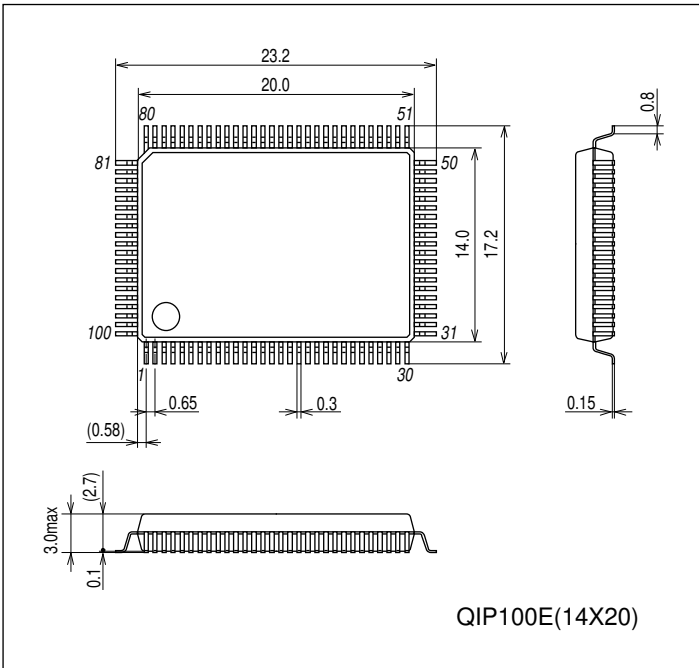

Package Dimensions

unit : mm (typ)

3274

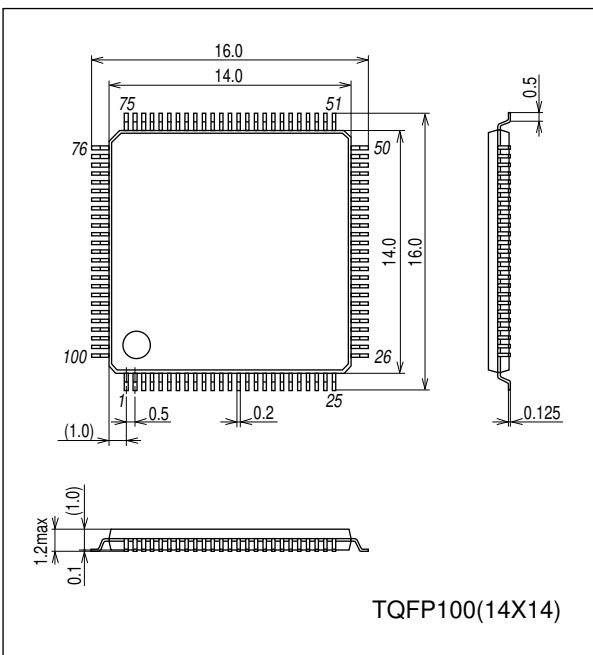

LC87F7DC8A

Pin Assignments

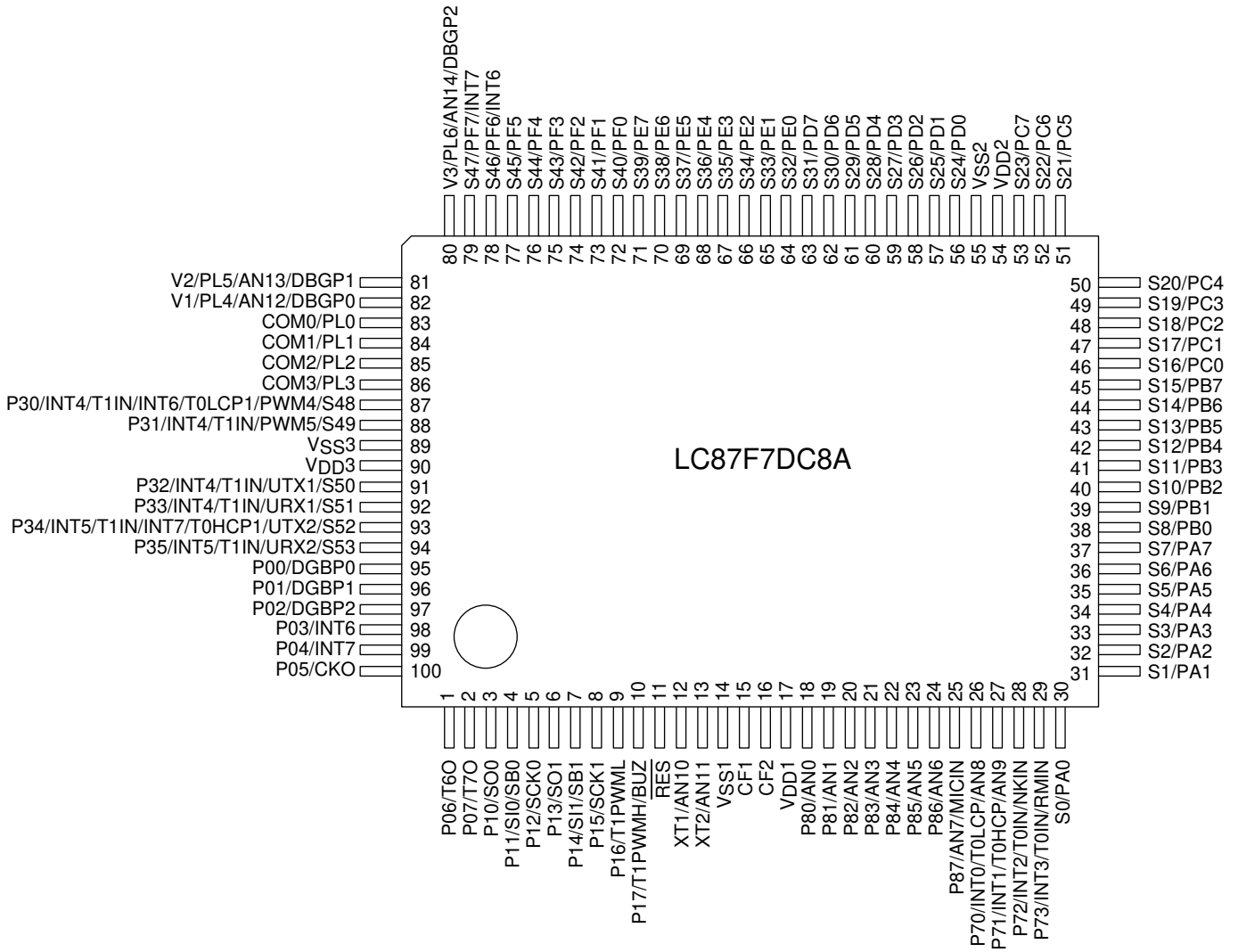

Top view

QIP100E(14×20) “Lead-free Type”

LC87F7DC8A

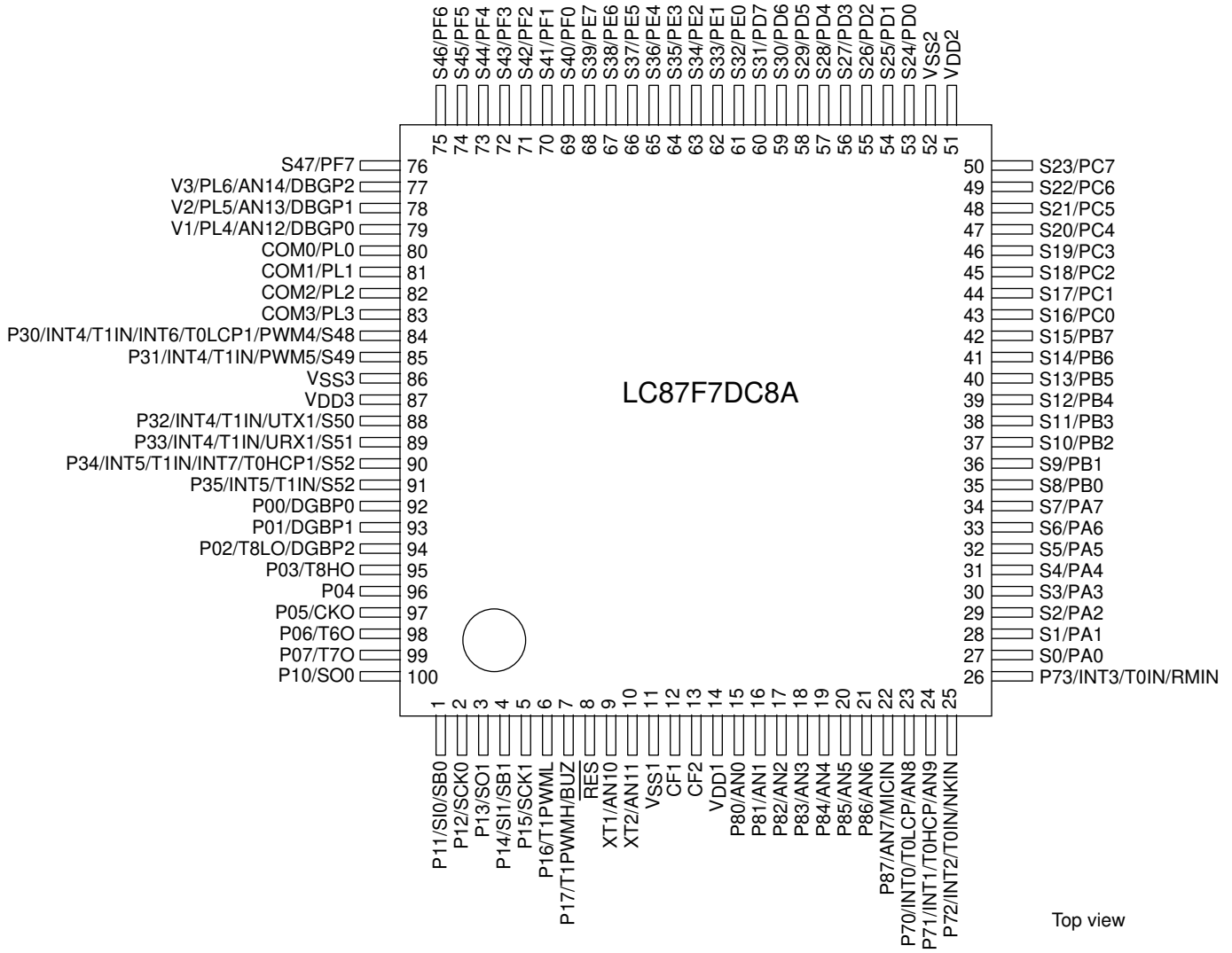

Top view

TQFP100(14×14) “Lead-free type/Halogen-free type”

LC87F7DC8A

System Block Diagram

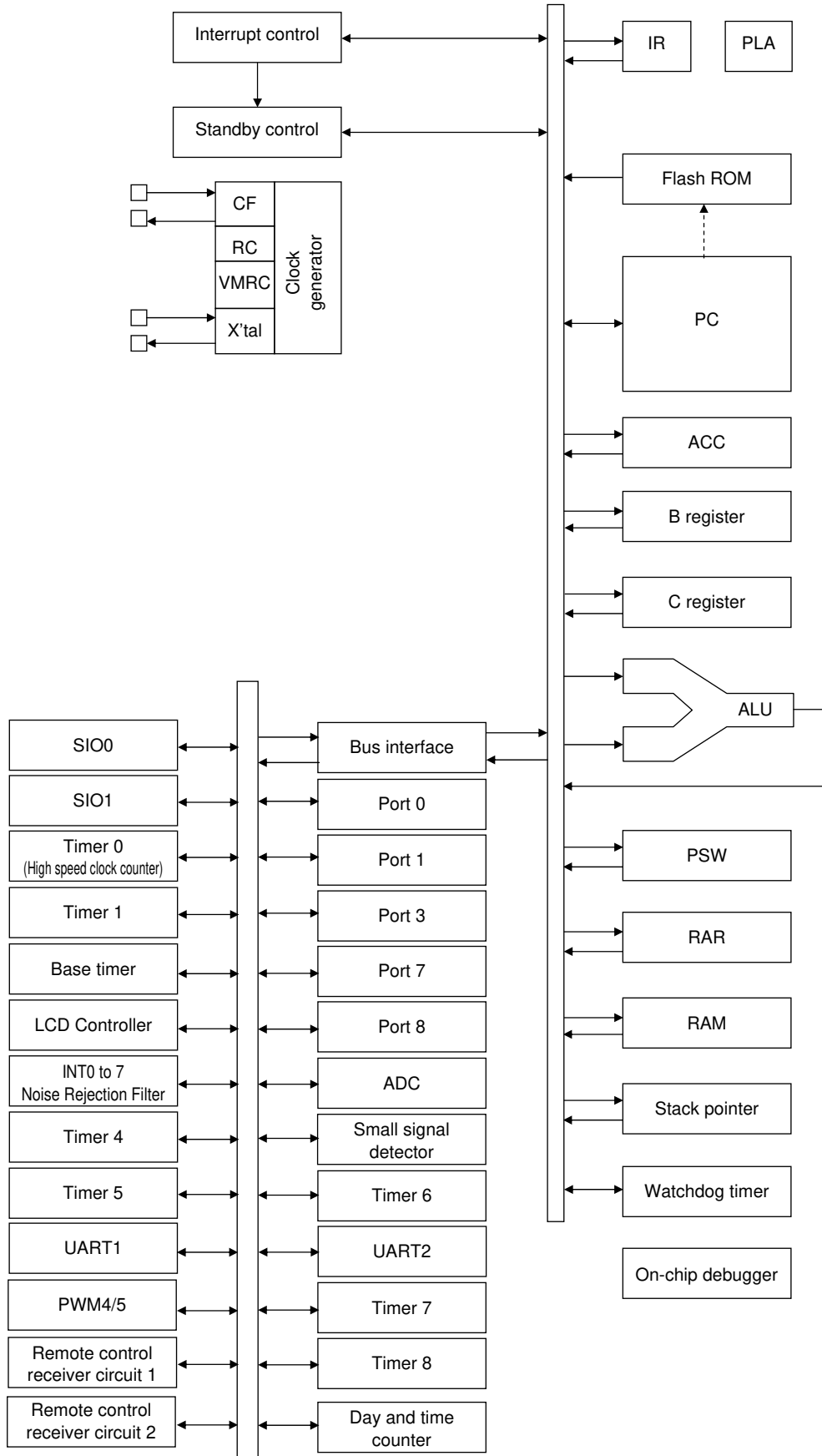

LC87F7DC8A

Pin Description

Pin Name	I/O	Description	Option																														
V _{SS} 1 V _{SS} 2 V _{SS} 3	-	- power supply pin	No																														
V _{DD} 1 V _{DD} 2 V _{DD} 3	-	+ power supply pin	No																														
Port 0 P00 to P07	I/O	<ul style="list-style-type: none"> • 8-bit I/O port • I/O specifiable in 1-bit units • Pull-up resistors can be turned on and off in 1-bit units. • Input for HOLD release • Input for port 0 interrupt • Shared pins P03: INT6 input P04: INT7 input P05: Clock output (system clock/can selected from sub clock) P06: Timer 6 toggle output P07: Timer 7 toggle output On chip debugger pins: DBGP0 to DBGP2(P00 to P02) 	Yes																														
Port 1 P10 to P17	I/O	<ul style="list-style-type: none"> • 8-bit I/O port • I/O specifiable in 1-bit units • Pull-up resistors can be turned on and off in 1-bit units. • Shared pins P10: SIO0 data output P11: SIO0 data input/bus I/O P12: SIO0 clock I/O P13: SIO1 data output P14: SIO1 data input/bus I/O P15: SIO1 clock I/O P16: Timer 1PWM output P17: Timer 1PWMH output/beeper output 	Yes																														
Port 3 P30 to P35	I/O	<ul style="list-style-type: none"> • 6-bit I/O port • Segment output for LCD • I/O specifiable in 1-bit units • Pull-up resistors can be turned on and off in 1-bit units. • Shared pins P30 to P33: INT4 input/HOLD release input/timer 1 event input/timer 0L capture input/ timer 0H capture input P34 to P35: INT5 input/HOLD release input/timer 1 event input/timer 0L capture input/ timer 0H capture input P30: PWM4 output/INT6 input/timer 0L capture 1 input P31: PWM5 output P32: UART1 transmit P33: UART1 receive P34: UART2 transmit/INT7 input/timer 0H capture 1 input P35: UART2 receive <p>Interrupt acknowledge type</p> <table border="1" style="width: 100%; border-collapse: collapse; text-align: center;"> <thead> <tr> <th></th> <th>Rising</th> <th>Falling</th> <th>Rising & Falling</th> <th>H level</th> <th>L level</th> </tr> </thead> <tbody> <tr> <td>INT4</td> <td>enable</td> <td>enable</td> <td>enable</td> <td>disable</td> <td>disable</td> </tr> <tr> <td>INT5</td> <td>enable</td> <td>enable</td> <td>enable</td> <td>disable</td> <td>disable</td> </tr> <tr> <td>INT6</td> <td>enable</td> <td>enable</td> <td>enable</td> <td>disable</td> <td>disable</td> </tr> <tr> <td>INT7</td> <td>enable</td> <td>enable</td> <td>enable</td> <td>disable</td> <td>disable</td> </tr> </tbody> </table>		Rising	Falling	Rising & Falling	H level	L level	INT4	enable	enable	enable	disable	disable	INT5	enable	enable	enable	disable	disable	INT6	enable	enable	enable	disable	disable	INT7	enable	enable	enable	disable	disable	Yes
	Rising	Falling	Rising & Falling	H level	L level																												
INT4	enable	enable	enable	disable	disable																												
INT5	enable	enable	enable	disable	disable																												
INT6	enable	enable	enable	disable	disable																												
INT7	enable	enable	enable	disable	disable																												

Continued on next page.

LC87F7DC8A

Continued from preceding page.

Pin Name	I/O	Description	Option																														
Port 7 P70 to P73	I/O	<ul style="list-style-type: none"> • 4-bit I/O port • I/O specifiable in 1-bit units • Pull-up resistors can be turned on and off in 1-bit units. • Shared pins P70: INT0 input/HOLD release input/timer 0L capture input/watchdog timer output P71: INT1 input/HOLD release input/timer 0H capture input P72: INT2 input/HOLD release input/timer 0 event input/timer 0L capture input/ high speed clock counter input P73: INT3 input (with noise filter)/timer 0 event input/timer 0H capture input/ remote control receiver input AD converter input ports: AN8 (P70), AN9 (P71) Interrupt acknowledge type <table border="1" style="margin-left: 20px;"> <thead> <tr> <th></th> <th>Rising</th> <th>Falling</th> <th>Rising & Falling</th> <th>H level</th> <th>L level</th> </tr> </thead> <tbody> <tr> <td>INT0</td> <td>enable</td> <td>enable</td> <td>disable</td> <td>enable</td> <td>enable</td> </tr> <tr> <td>INT1</td> <td>enable</td> <td>enable</td> <td>disable</td> <td>enable</td> <td>enable</td> </tr> <tr> <td>INT2</td> <td>enable</td> <td>enable</td> <td>enable</td> <td>disable</td> <td>disable</td> </tr> <tr> <td>INT3</td> <td>enable</td> <td>enable</td> <td>enable</td> <td>disable</td> <td>disable</td> </tr> </tbody> </table>		Rising	Falling	Rising & Falling	H level	L level	INT0	enable	enable	disable	enable	enable	INT1	enable	enable	disable	enable	enable	INT2	enable	enable	enable	disable	disable	INT3	enable	enable	enable	disable	disable	No
	Rising	Falling	Rising & Falling	H level	L level																												
INT0	enable	enable	disable	enable	enable																												
INT1	enable	enable	disable	enable	enable																												
INT2	enable	enable	enable	disable	disable																												
INT3	enable	enable	enable	disable	disable																												
Port 8 P80 to P87	I/O	<ul style="list-style-type: none"> • 8-bit I/O port • I/O specifiable in 1-bit units • Shared pins AD converter input ports: AN0 to AN7 Small signal detector input port: MICIN (P87)	No																														
S0/PA0 to S7/PA7	I/O	<ul style="list-style-type: none"> • Segment output for LCD • Can be used as general-purpose I/O port (PA) 	No																														
S8/PB0 to S15/PB7	I/O	<ul style="list-style-type: none"> • Segment output for LCD • Can be used as general-purpose I/O port (PB) 	No																														
S16/PC0 to S23/PC7	I/O	<ul style="list-style-type: none"> • Segment output for LCD • Can be used as general-purpose I/O port (PC) 	No																														
S24/PD0 to S31/PD7	I/O	<ul style="list-style-type: none"> • Segment output for LCD • Can be used as general-purpose I/O port (PD) 	No																														
S32/PE0 to S39/PE7	I/O	<ul style="list-style-type: none"> • Segment output for LCD • Can be used as general-purpose I/O port (PE) 	No																														
S40/PF0 to S47/PF7	I/O	<ul style="list-style-type: none"> • Segment output for LCD • Can be used as general-purpose I/O port (PF) PF6: INT6 input PF7: INT7 input	No																														
COM0/PL0 to COM3/PL3	I/O	<ul style="list-style-type: none"> • Common output for LCD • Can be used as general-purpose input port (PL) 	No																														
V1/PL4 to V3/PL6	I/O	<ul style="list-style-type: none"> • LCD output bias power supply • Can be used as general-purpose input port (PL) • Shared pins AD converter input ports: AN12 (V1) to AN14 (V3) On-chip debugger pins: DBGP0 (V1) to DBGP2 (V3)	No																														
$\overline{\text{RES}}$	Input	Reset pin	No																														
XT1	Input	<ul style="list-style-type: none"> • 32.768kHz crystal oscillator input pin • Shared pins General-purpose input port AD converter input port: AN10 Must be connected to V_{DD1} if not to be used.	No																														
XT2	I/O	<ul style="list-style-type: none"> • 32.768kHz crystal oscillator output pin • Shared pins General-purpose I/O port AD converter input port: AN11 Must be set for oscillation and kept open if not to be used.	No																														
CF1	Input	Ceramic resonator input pin	No																														
CF2	Output	Ceramic resonator output pin	No																														

LC87F7DC8A

Port Output Types

The table below lists the types of port outputs and the presence/absence of a pull-up resistor. Data can be read into any input port even if it is in the output mode.

Port Name	Option Selected in Units of	Option Type	Output Type	Pull-up Resistor
P00 to P07	each bit	1	CMOS	Programmable
		2	Nch-open drain	Programmable
P10 to P17	each bit	1	CMOS	Programmable
		2	Nch-open drain	Programmable
P30 to P35	each bit	1	CMOS	Programmable
		2	Nch-open drain	Programmable
P70	-	No	Nch-open drain	Programmable
P71 to P73	-	No	CMOS	Programmable
P80 to P87	-	No	Nch-open drain	No
S0/PA0 to S47/PF7	-	No	CMOS	Programmable
COM0/PL0 to COM3/PL3	-	No	Input only	No
V1/PL4 to V3/PL6	-	No	Input only	No
XT1	-	No	Input only	No
XT2	-	No	Output for 32.768kHz crystal oscillator (Nch-open drain when in general-purpose output mode)	No

User Option List

Option Name	Option Type	Mask Version *1	Flash Version	Option Selected in Units of	Specified item
Port output form	P00 to P07	○	○	each bit	CMOS
					Nch-open drain
	P10 to P17	○	○	each bit	CMOS
					Nch-open drain
	P30 to P35	○	○	each bit	CMOS
					Nch-open drain
Program start address	-	× *2	○	-	00000H
					1FF00H

*1: Mask option selection - No change possible after the mask is completed.

*2: Program start address of the mask version is 00000h.

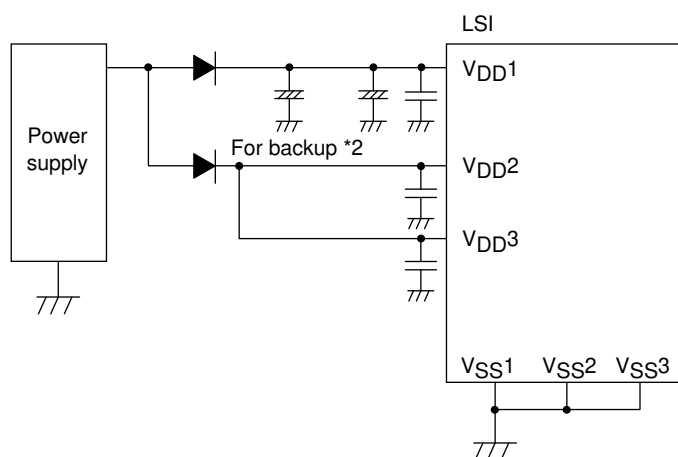

*1 Connect the IC as shown below to minimize the noise input to the VDD1 pin.

Be sure to electrically short the VSS1, VSS2, and VSS3 pins.

*2 The internal memory is sustained by VDD1. If none of VDD2 and VDD3 are backed up, the high level output at the ports are unstable in the HOLD backup mode, allowing through current to flow into the input buffer and thus shortening the backup time.

Make sure that the port outputs are held at the low level in the HOLD backup mode.

LC87F7DC8A

Absolute Maximum Ratings at Ta = 25°C, VSS1 = VSS2 = VSS3 = 0V

Parameter	Symbol	Pin/Remarks	Conditions	Specification				unit
				V _{DD} [V]	min	typ	max	
Maximum supply voltage	V _{DD} max	V _{DD} 1, V _{DD} 2, V _{DD} 3	V _{DD} 1=V _{DD} 2=V _{DD} 3		-0.3		+6.5	V
supply voltage for LCD	V _{LCD}	V1/PL4, V2/PL5, V3/PL6	V _{DD} 1=V _{DD} 2=V _{DD} 3		-0.3		V _{DD}	
Input voltage	V _I (1)	Port L XT1, CF1, $\overline{\text{RES}}$			-0.3		V _{DD} +0.3	
Input/output voltage	V _{IO} (1)	Ports 0, 1, 3, 7, 8 Ports A, B, C Ports D, E, F XT2			-0.3		V _{DD} +0.3	
High level output current	Peak output current	IOPH(1)	Ports 0, 1, 32 to 35	• CMOS output selected • Current at each pin		-10		mA
		IOPH(2)	Ports 30, 31	• CMOS output selected • Current at each pin		-20		
		IOPH(3)	Ports 71 to 73	Current at each pin		-5		
		IOPH(4)	Ports A, B, C Ports D, E, F	Current at each pin		-5		
	Mean output current (Note 1-1)	IOMH(1)	Ports 0, 1, 32 to 35	• CMOS output selected • Current at each pin		-7.5		
		IOMH(2)	Ports 30, 31	• CMOS output selected • Current at each pin		-15		
		IOMH(3)	Ports 71 to 73	Current at each pin		-3		
		IOMH(4)	Ports A, B, C Ports D, E, F	Current at each pin		-3		
	Total output current	ΣIOAH(1)	Ports 0, 1, 32 to 35	Total of all pins		-25		
		ΣIOAH(2)	Ports 30, 31	Total of all pins		-25		
		ΣIOAH(3)	Ports 0, 1, 3	Total of all pins		-45		
		ΣIOAH(4)	Ports 71 to 73	Total of all pins		-5		
		ΣIOAH(5)	Ports A, B, C	Total of all pins		-25		
		ΣIOAH(6)	Ports D, E, F	Total of all pins		-25		
ΣIOAH(7)		Ports A, B, C Ports D, E, F	Total of all pins		-45			
Low level output current	Peak output current	IOPL(1)	Ports 0, 1, 32 to 35	Current at each pin			20	
		IOPL(2)	Ports 30, 31	Current at each pin			30	
		IOPL(3)	Ports 7, 8 XT2	Current at each pin			10	
		IOPL(4)	Ports A, B, C Ports D, E, F	Current at each pin			10	
	Mean output current (Note 1-1)	IOML(1)	Ports 0, 1, 32 to 35	Current at each pin			15	
		IOML(2)	Ports 30, 31	Current at each pin			20	
		IOML(3)	Ports 7, 8 XT2	Current at each pin			7.5	
		IOML(4)	Ports A, B, C Ports D, E, F	Current at each pin			7.5	
	Total output current	ΣIOAL(1)	Ports 0, 1, 32 to 35	Total of all pins			45	
		ΣIOAL(2)	Ports 30, 31	Total of all pins			45	
		ΣIOAL(3)	Ports 0, 1, 3	Total of all pins			80	
		ΣIOAL(4)	Ports 7, 8 XT2	Total of all pins			20	
		ΣIOAL(5)	Ports A, B, C	Total of all pins			45	
ΣIOAL(6)		Ports D, E, F	Total of all pins			45		
ΣIOAL(7)		Ports A, B, C Ports D, E, F	Total of all pins			80		
Maximum power dissipation	Pd max	QIP100E(14×20)	Ta=-40 to +85°C				mW	
		TQFP100(14×14)	Ta=-40 to +85°C					

Note 1-1: The mean output current is a mean value measured over 100ms.

Continued on next page.

LC87F7DC8A

Continued from preceding page.

Parameter	Symbol	Pin/Remarks	Conditions	Specification				
				V _{DD} [V]	min	typ	max	unit
Operating ambient temperature	T _{opr}				-40		+85	°C
Storage ambient temperature	T _{stg}				-55		+125	

Stresses exceeding Maximum Ratings may damage the device. Maximum Ratings are stress ratings only. Functional operation above the Recommended Operating Conditions is not implied. Extended exposure to stresses above the Recommended Operating Conditions may affect device reliability.

Allowable Operating Range at T_a = -40°C to +85°C, V_{SS1} = V_{SS2} = V_{SS3} = 0V

Parameter	Symbol	Pin/Remarks	Conditions	Specification				
				V _{DD} [V]	min	typ	max	unit
Operating supply voltage (Note 2-1)	V _{DD} (1)	V _{DD} 1=V _{DD} 2=V _{DD} 3	0.237μs ≤ tCYC ≤ 200μs		3.0		5.5	V
	V _{DD} (2)		0.356μs ≤ tCYC ≤ 200μs		2.5		5.5	
	V _{DD} (3)		0.712μs ≤ tCYC ≤ 200μs		2.2		5.5	
Memory sustaining supply voltage	V _H D	V _{DD} 1	RAM and register contents sustained in HOLD mode.		2.0		5.5	
High level input voltage	V _I H(1)	Ports 0, 3, 8 Ports A, B, C, D, E, F Port L	Output disabled	2.2 to 5.5	0.3V _{DD} +0.7		V _{DD}	V
	V _I H(2)	Port 1 Ports 71 to 73 P70 port input/ interrupt side	• Output disabled • When INT1VTSL=0 (P71 only)	2.2 to 5.5	0.3V _{DD} +0.7		V _{DD}	
	V _I H(3)	P71 interrupt side	• Output disabled • When INT1VTSL=1	2.2 to 5.5	0.85V _{DD}		V _{DD}	
	V _I H(4)	P87 small signal input side	Output disabled	2.2 to 5.5	0.75V _{DD}		V _{DD}	
	V _I H(5)	P70 watchdog timer side	Output disabled	2.2 to 5.5	0.9V _{DD}		V _{DD}	
	V _I H(6)	XT1,XT2,CF1, $\overline{\text{RES}}$		2.2 to 5.5	0.75V _{DD}		V _{DD}	
Low level input voltage	V _I L(1)	Ports 0, 3, 8 Ports A, B, C, D, E, F Port L	Output disabled	4.0 to 5.5	V _{SS}		0.15V _{DD} +0.4	V
				2.2 to 4.0	V _{SS}		0.2V _{DD}	
	V _I L(2)	Port 1 Ports 71 to 73 P70 port input/ interrupt side	• Output disabled • When INT1VTSL=0 (P71 only)	4.0 to 5.5	V _{SS}		0.1V _{DD} +0.4	
				2.2 to 4.0	V _{SS}		0.2V _{DD}	
	V _I L(3)	P71 interrupt side	• Output disabled • When INT1VTSL=1	2.2 to 5.5	V _{SS}		0.45V _{DD}	
	V _I L(4)	P87 small signal input side	Output disabled	2.2 to 5.5	V _{SS}		0.25V _{DD}	
V _I L(5)	P70 watchdog timer side	Output disabled	2.2 to 5.5	V _{SS}		0.8V _{DD} -1.0		
V _I L(6)	XT1,XT2,CF1, $\overline{\text{RES}}$		2.2 to 5.5	V _{SS}		0.25V _{DD}		
Instruction cycle time (Note 2-2)	tCYC			3.0 to 5.5	0.237		200	μs
				2.5 to 5.5	0.356		200	
				2.2 to 5.5	0.712		200	
External system clock frequency	FEXCF(1)	CF1	• CF2 pin open • System clock frequency division ratio=1/1 • External system clock duty=50±5%	3.0 to 5.5	0.1		12	MHz
				2.5 to 5.5	0.1		8	
				2.2 to 5.5	0.1		4	
			• CF2 pin open • System clock frequency division ratio=1/2	3.0 to 5.5	0.2		24.4	
				2.5 to 5.5	0.2		16	
				2.2 to 5.5	0.2		8	

Note 2-1: V_{DD} must be held greater than or equal to 3.0V in the flash ROM onboard programming mode.

Note 2-2: Relationship between tCYC and oscillation frequency is 3/FmCF at a division ratio of 1/1 and 6/FmCF at a division ratio of 1/2.

Continued on next page.

LC87F7DC8A

Continued from preceding page.

Parameter	Symbol	Pin/Remarks	Conditions	Specification				
				V _{DD} [V]	min	typ	max	unit
Oscillation frequency range (Note 2-3)	FmCF(1)	CF1, CF2	• 12MHz ceramic oscillation • See Fig. 1.	3.0 to 5.5		12		MHz
	FmCF(2)	CF1, CF2	• 8MHz ceramic oscillation • See Fig. 1.	2.5 to 5.5		8		
	FmCF(3)	CF1, CF2	• 4MHz ceramic oscillation • See Fig. 1.	2.2 to 5.5		4		
	FmRC		Internal RC oscillation	2.2 to 5.5	0.3	1.0	2.0	
	FmVMRC(1)		• Frequency variable RC source oscillation • When VMRAJ2 to 0=4, VMFAJ2 to 0=0, VMSSL4M=0	2.2 to 5.5		10		
	FmVMRC(2)		• Frequency variable RC source oscillation • When VMRAJ2 to 0=4, VMFAJ2 to 0=0, VMSSL4M=1	2.2 to 5.5		4		
	FsX'tal	XT1, XT2	• 32.768kHz crystal oscillation • See Fig. 2.	2.2 to 5.5		32.768		kHz
Frequency variable RC oscillation usable range	OpVMRC(1)		When VMSSL4M=0	2.2 to 5.5	8	10	12	MHz
	OpVMRC(2)		When VMSSL4M=1	2.2 to 5.5	3.5	4	4.5	
Frequency variable RC oscillation adjustment range	VmADJ(1)		Each step of VMRAJn (Wide range)	2.2 to 5.5	8	24	64	%
	VmADJ(2)		Each step of VMFAJn (Small range)	2.2 to 5.5	1	4	8	

Note 2-3: See Tables 1 and 2 for the oscillation constants.

Electrical Characteristics at Ta = -40°C to +85°C, V_{SS1} = V_{SS2} = V_{SS3} = 0V

Parameter	Symbol	Pin/Remarks	Conditions	Specification				
				V _{DD} [V]	min	typ	max	unit
High level input current	I _{IH} (1)	Ports 0, 1, 3, 7, 8 Ports A, B, C Ports D, E, F Port L	• Output disabled • Pull-up resistor off • V _{IN} =V _{DD} (Including output Tr's off leakage current)	2.2 to 5.5			1	μA
	I _{IH} (2)	$\overline{\text{RES}}$	V _{IN} =V _{DD}	2.2 to 5.5			1	
	I _{IH} (3)	XT1, XT2	• For input port specification • V _{IN} =V _{DD}	2.2 to 5.5			1	
	I _{IH} (4)	CF1	V _{IN} =V _{DD}	2.2 to 5.5			15	
	I _{IH} (5)	P87 small signal input side	V _{IN} =VBIS+0.5V (VBIS: Bias voltage)	4.5 to 5.5 2.2 to 4.5	4.2 1.5	8.5 5.5	15 10	
Low level input current	I _{IL} (1)	Ports 0, 1, 3, 7, 8 Ports A, B, C Ports D, E, F Port L	• Output disabled • Pull-up resistor off • V _{IN} =V _{SS} (Including output Tr's off leakage current)	2.2 to 5.5	-1			μA
	I _{IL} (2)	$\overline{\text{RES}}$	V _{IN} =V _{SS}	2.2 to 5.5	-1			
	I _{IL} (3)	XT1, XT2	• For input port specification • V _{IN} =V _{SS}	2.2 to 5.5	-1			
	I _{IL} (4)	CF1	V _{IN} =V _{SS}	2.2 to 5.5	-15			
	I _{IL} (5)	P87 small signal input side	V _{IN} =VBIS-0.5V (VBIS: Bias voltage)	4.5 to 5.5 2.2 to 4.5	-15 -10	-8.5 -5.5	-4.2 -1.5	

Continued on next page.

LC87F7DC8A

Continued from preceding page.

Parameter	Symbol	Pin/Remarks	Conditions	Specification				unit
				V _{DD} [V]	min	typ	max	
High level output voltage	V _{OH} (1)	Ports 0, 1, 32 to 35	I _{OH} =-1mA	4.5 to 5.5	V _{DD} -1			V
	V _{OH} (2)		I _{OH} =-0.4mA	3.0 to 5.5	V _{DD} -0.4			
	V _{OH} (3)		I _{OH} =-0.2mA	2.2 to 5.5	V _{DD} -0.4			
	V _{OH} (4)	Ports 30, 31	I _{OH} =-10mA	4.5 to 5.5	V _{DD} -1.5			
	V _{OH} (5)		I _{OH} =-1.6mA	3.0 to 5.5	V _{DD} -0.4			
	V _{OH} (6)		I _{OH} =-1mA	2.2 to 5.5	V _{DD} -0.4			
	V _{OH} (7)	Ports 71 to 73	I _{OH} =-0.4mA	3.0 to 5.5	V _{DD} -0.4			
	V _{OH} (8)		I _{OH} =-0.2mA	2.2 to 5.5	V _{DD} -0.4			
	V _{OH} (9)	Ports A, B, C	I _{OH} =-1mA	4.5 to 5.5	V _{DD} -1			
	V _{OH} (10)	Ports D, E, F	I _{OH} =-0.4mA	3.0 to 5.5	V _{DD} -0.4			
	V _{OH} (11)		I _{OH} =-0.2mA	2.2 to 5.5	V _{DD} -0.4			
Low level output voltage	V _{OL} (1)	Ports 0, 1, 32 to 35	I _{OL} =10mA	4.5 to 5.5			1.5	
	V _{OL} (2)		I _{OL} =1.6mA	3.0 to 5.5			0.4	
	V _{OL} (3)	Ports 30,31 (PWM function output mode)	I _{OL} =1mA	2.2 to 5.5			0.4	
	V _{OL} (4)	Ports 30, 31 (Port function output mode)	I _{OL} =30mA	4.5 to 5.5			1.5	
	V _{OL} (5)		I _{OL} =5mA	3.0 to 5.5			0.4	
	V _{OL} (6)		I _{OL} =2.5mA	2.2 to 5.5			0.4	
	V _{OL} (7)	Ports 7, 8	I _{OL} =1.6mA	3.0 to 5.5			0.4	
	V _{OL} (8)	XT2	I _{OL} =1mA	2.2 to 5.5			0.4	
	V _{OL} (9)	Ports A, B, C	I _{OL} =1.6mA	3.0 to 5.5			0.4	
	V _{OL} (10)	Ports D, E, F	I _{OL} =1mA	2.2 to 5.5			0.4	
LCD output voltage regulation	VODLS	S0 to S53	<ul style="list-style-type: none"> • I_O=0mA • VLCD, 2/3VLCD,1/3VLCD level output • See Fig. 8. 	2.2 to 5.5	0		±0.2	
	VODLC	COM0 to COM3	<ul style="list-style-type: none"> • I_O=0mA • VLCD, 2/3VLCD,1/2VLCD, 1/3VLCD level output • See Fig. 8. 	2.2 to 5.5	0		±0.2	
LCD bias resistor	RLCD(1)	Resistance per one bias resistor	See Fig. 8.	2.2 to 5.5		60	kΩ	
	RLCD(2)	Resistance per one bias resistor 1/2 mode	See Fig. 8.	2.2 to 5.5		30		
Resistance of pull-up MOS Tr.	Rpu(1)	Ports 0, 1, 3, 7	V _{OH} =0.9V _{DD}	4.5 to 5.5	15	35	80	
	Rpu(2)	Ports A, B, C Ports D, E, F		2.2 to 5.5	18	50	150	
Hysteresis voltage	VHYS(1)	Ports 1, 7 RES		2.2 to 5.5		0.1V _{DD}	V	
	VHYS(2)	P87 small signal input side		2.2 to 5.5		0.1V _{DD}		
Pin capacitance	CP	All pins	<ul style="list-style-type: none"> • For pins other than that under test: V_{IN}=V_{SS} • f=1MHz • Ta=25°C 	2.2 to 5.5		10	pF	
Input sensitivity	Vsen	P87 small signal input side		2.2 to 5.5	0.12V _{DD}		Vp-p	

LC87F7DC8A

Serial I/O Characteristics at Ta = -40°C to +85°C, V_{SS1} = V_{SS2} = V_{SS3} = 0V

1. SIO0 Serial I/O Characteristics (Note 4-1-1)

Parameter		Symbol	Pin/Remarks	Conditions	V _{DD} [V]	Specification					
						min	typ	max	unit		
Serial clock	Input clock	Frequency	tSCK(1)	SCK0(P12)	See Fig. 6.	2.2 to 5.5	2			tCYC	
		Low level pulse width	tSCKL(1)				1				
		High level pulse width	tSCKH(1)				1				
			tSCKHA(1)								
	Output clock	Frequency	tSCK(2)	SCK0(P12)	<ul style="list-style-type: none"> • CMOS output selected • See Fig. 6. 	2.2 to 5.5	4/3			tSCK	
		Low level pulse width	tSCKL(2)				1/2				
High level pulse width		tSCKH(2)	1/2								
		tSCKHA(2)	<ul style="list-style-type: none"> • Continuous data transmission/reception mode • CMOS output selected • See Fig. 6. 				tSCKH(2) +2tCYC		tSCKH(2) +(10/3) tCYC	tCYC	
Serial input	Data setup time	tsDI(1)	SB0(P11), SI0(P11)	<ul style="list-style-type: none"> • Must be specified with respect to rising edge of SIOCLK. • See Fig. 6. 	2.2 to 5.5	0.03					
	Data hold time	thDI(1)				2.2 to 5.5	0.03				
Serial output	Input clock	Output delay time	tdD0(1)	SO0(P10), SB0(P11)	<ul style="list-style-type: none"> • Continuous data transmission/reception mode • (Note 4-1-3) 	2.2 to 5.5			(1/3)tCYC +0.05	μs	
			tdD0(2)				<ul style="list-style-type: none"> • Synchronous 8-bit mode • (Note 4-1-3) 	2.2 to 5.5			
	tdD0(3)		(Note 4-1-3)				2.2 to 5.5				

Note 4-1-1: These specifications are theoretical values. Add margin depending on its use.

Note 4-1-2: To use serial-clock-input in continuous trans/rec mode, a time from SIORUN being set when serial clock is "H" to the first negative edge of the serial clock must be longer than tSCKHA.

Note 4-1-3: Must be specified with respect to falling edge of SIOCLK. Must be specified as the time to the beginning of output state change in open drain output mode. See Fig. 6.

LC87F7DC8A

2. SIO1 Serial I/O Characteristics (Note 4-2-1)

Parameter		Symbol	Pin/Remarks	Conditions	V _{DD} [V]	Specification				
						min	typ	max	unit	
Serial clock	Input clock	Frequency	tSCK(3)	SCK1(P15)	See Fig. 6.	2.2 to 5.5	2			tCYC
		Low level pulse width	tSCKL(3)				1			
		High level pulse width	tSCKH(3)				1			
	Output clock	Frequency	tSCK(4)	SCK1(P15)	<ul style="list-style-type: none"> • CMOS output selected • See Fig. 6. 	2.2 to 5.5	2			tSCK
		Low level pulse width	tSCKL(4)				1/2			
		High level pulse width	tSCKH(4)				1/2			
Serial input	Data setup time	tsDI(2)	SB1(P14), S11(P14)	<ul style="list-style-type: none"> • Must be specified with respect to rising edge of SIOCLK. • See Fig. 6. 	2.2 to 5.5	0.03				
	Data hold time	thDI(2)				0.03				
Serial output	Output delay time	tdD0(4)	SO1(P13), SB1(P14)	<ul style="list-style-type: none"> • Must be specified with respect to falling edge of SIOCLK. • Must be specified as the time to the beginning of output state change in open drain output mode. • See Fig. 6. 	2.2 to 5.5			(1/3)tCYC +0.05	μs	

Note 4-2-1: These specifications are theoretical values. Add margin depending on its use.

Pulse Input Conditions at Ta = -40°C to +85°C, V_{SS1} = V_{SS2} = V_{SS3} = 0V

Parameter	Symbol	Pin/Remarks	Conditions	V _{DD} [V]	Specification			
					min	typ	max	unit
High/low level pulse width	tPIH(1) tPIL(1)	INT0(P70), INT1(P71), INT2(P72), INT4(P30 to P33), INT5(P34 to P35), INT6(P30), INT7(P34)	<ul style="list-style-type: none"> • Interrupt source flag can be set. • Event inputs for timer 0 or 1 are enabled. 	2.2 to 5.5	1			tCYC
	tPIH(2) tPIL(2)	INT3(P73) when noise filter time constant is 1/1	<ul style="list-style-type: none"> • Interrupt source flag can be set. • Event inputs for timer 0 are enabled. 	2.2 to 5.5	2			
	tPIH(3) tPIL(3)	INT3(P73) when noise filter time constant is 1/32	<ul style="list-style-type: none"> • Interrupt source flag can be set. • Event inputs for timer 0 are enabled. 	2.2 to 5.5	64			
	tPIH(4) tPIL(4)	INT3(P73) when noise filter time constant is 1/128	<ul style="list-style-type: none"> • Interrupt source flag can be set. • Event inputs for timer 0 are enabled. 	2.2 to 5.5	256			
	tPIH(5) tPIL(5)	MICIN(P87)	Condition that signal is accepted to small signal detection counter.	2.2 to 5.5	1			
	tPIH(6) tPIL(6)	RMIN(P73)	Condition that signal is accepted to remote control receiver circuit.	2.2 to 5.5	4			RMCK (Note5-1)
	tPIL(7)	$\overline{\text{RES}}$	Resetting is enabled.	2.2 to 5.5	200			μs

Note 5-1: RMCK is an unit for the base clock (40tCYC/50tCYC/Sub-Clock) of remote control receiver circuit.

LC87F7DC8A

AD Converter Characteristics at $V_{SS1} = V_{SS2} = V_{SS3} = 0V$

<12bits AD Converter Mode at $T_a = -xx$ to $+xx^\circ C$ > To be determined after evaluation

Parameter	Symbol	Pin/Remarks	Conditions	Specification				
				$V_{DD}[V]$	min	typ	max	unit
Resolution	N	AN0(P80) to				12		bit
Absolute accuracy	ET	AN7(P87), AN8(P70), AN9(P71), AN10(XT1), AN11(XT2)	(Note 6-1)					LSB
			(Note 6-1) $T_a = -10$ to $+50^\circ C$					
Conversion time	tCAD		• See Conversion time calculation formulas. (Note 6-2) $T_a = -10$ to $+50^\circ C$					μs
			• See Conversion time calculation formulas. (Note 6-2)					
Analog input voltage range	VAIN				V_{SS}		V_{DD}	V
Analog port input current	IAINH		$VAIN = V_{DD}$				1	μA
	IAINL		$VAIN = V_{SS}$		-1			

<8bits AD Converter Mode at $T_a = -30$ to $+70^\circ C$ >

Parameter	Symbol	Pin/Remarks	Conditions	Specification				
				$V_{DD}[V]$	min	typ	max	unit
Resolution	N	AN0(P80) to		3.0 to 5.5		8		bit
Absolute accuracy	ET	AN7(P87), AN8(P70), AN9(P71), AN10(XT1), AN11(XT2)	(Note 6-1)	3.0 to 5.5			1.5	LSB
			• See Conversion time calculation formulas. (Note 6-2)	4.0 to 5.5				
Conversion time	TCAD			3.0 to 5.5				μs
				3.0 to 5.5				
Analog input voltage range	VAIN			3.0 to 5.5	V_{SS}		V_{DD}	V
Analog port input current	IAINH		$VAIN = V_{DD}$	3.0 to 5.5			1	μA
	IAINL		$VAIN = V_{SS}$	3.0 to 5.5		-1		

<Conversion time calculation formulas>

12bits AD Converter Mode: $TCAD(\text{Conversion time}) = ((52 / (\text{division ratio})) + 2) \times (1/3) \times tCYC$

8bits AD Converter Mode: $TCAD(\text{Conversion time}) = ((32 / (\text{division ratio})) + 2) \times (1/3) \times tCYC$

<Recommended Operating Conditions>

External oscillation FmCF [MHz]	Operating supply voltage range V_{DD} [V]	System division ratio (SYSDIV)	Cycle time tCYC [ns]	AD division ratio (ADDIV)	AD conversion time (tCAD) [μs]	
					12bit AD	8bit AD
12	4.0 to 5.5	1/1	250	1/8	TBD	21.5
	3.0 to 5.5	1/1	250	1/16	TBD	42.8

Note 6-1: The quantization error ($\pm 1/2LSB$) must be excluded from the absolute accuracy. The absolute accuracy must be measured in the microcontroller's state in which no I/O operations occur at the pins adjacent to the analog input channel.

Note 6-2: The conversion time refers to the period from the time an instruction for starting a conversion process till the time the conversion results register(s) are loaded with a complete digital conversion value corresponding to the analog input value.

The conversion time is 2 times the normal-time conversion time when:

- The first AD conversion is performed in the 12-bit AD conversion mode after a system reset.
- The first AD conversion is performed after the AD conversion mode is switched from 8-bit to 12-bit conversion mode.

LC87F7DC8A

Consumption Current Characteristics at Ta = -40°C to +85°C, VSS1 = VSS2 = VSS3 = 0V

Parameter	Symbol	Pin/ Remarks	Conditions	Specification					
				V _{DD} [V]	min	typ	max	unit	
Normal mode consumption current (Note 7-1)	IDDOP(1)	V _{DD1} =V _{DD2} =V _{DD3}	<ul style="list-style-type: none"> • FmCF=12MHz ceramic oscillation mode • FmX'tal=32.768kHz crystal oscillation mode • System clock set to 12MHz side 	4.5 to 5.5		7.4	19.9	mA	
	IDDOP(2)			3.0 to 3.6		4.8	10.9		
	IDDOP(3)		<ul style="list-style-type: none"> • FmCF=8MHz ceramic oscillation mode • FmX'tal=32.768kHz crystal oscillation mode • System clock set to 8MHz side 	4.5 to 5.5		5.9	14.9		
	IDDOP(4)			3.0 to 3.6		3.9	8.8		
	IDDOP(5)		<ul style="list-style-type: none"> • Frequency variable RC oscillation stopped. • 1/1 frequency division ratio 	2.5 to 3.0		3	6.8		
	IDDOP(6)			4.5 to 5.5		3.4	8.5		
	IDDOP(7)		<ul style="list-style-type: none"> • FmCF=4MHz ceramic oscillation mode • FmX'tal=32.768kHz crystal oscillation mode • System clock set to 4MHz side 	3.0 to 3.6		2.4	5.3		
	IDDOP(8)			2.2 to 3.0		2.0	4.4		
	IDDOP(9)		<ul style="list-style-type: none"> • FmCF=0Hz (oscillation stopped) • FmX'tal=32.768kHz crystal oscillation mode • System clock set to internal RC oscillation 	4.5 to 5.5		0.6	3.1		
	IDDOP(10)			3.0 to 3.6		0.4	1.7		
	IDDOP(11)			2.2 to 3.0		0.3	1.35		
	IDDOP(12)		<ul style="list-style-type: none"> • FmCF=0Hz (oscillation stopped) • FmX'tal=32.768kHz crystal oscillation mode • Internal RC oscillation stopped. 	4.5 to 5.5		6.5	20.0		
	IDDOP(13)			3.0 to 3.6		4.2	12.0		
	IDDOP(14)		<ul style="list-style-type: none"> • FmCF=0Hz (oscillation stopped) • FmX'tal=32.768kHz crystal oscillation mode • Internal RC oscillation stopped. 	4.5 to 5.5		3.1	11.5		
	IDDOP(15)			3.0 to 3.6		2.0	6.6		
	IDDOP(16)			2.2 to 3.0		1.6	3.5		
	IDDOP(17)		<ul style="list-style-type: none"> • System clock set to 4MHz with frequency variable RC oscillation • 1/1 frequency division ratio 	4.5 to 5.5		44.4	128.7		μA
	IDDOP(18)			3.0 to 3.6		26.1	56.9		
	IDDOP(19)			2.2 to 3.0		13.0	43.3		

Note 7-1: The consumption current value includes none of the currents that flow into the output Tr and internal pull-up resistors.

Continued on next page.

LC87F7DC8A

Continued from preceding page.

Parameter	Symbol	Pin/ Remarks	Conditions	Specification				
				V _{DD} [V]	min	typ	max	unit
HALT mode consumption current (Note 7-1)	IDDHALT(1)	V _{DD1} =V _{DD2} =V _{DD3}	<ul style="list-style-type: none"> • HALT mode • FmCF=12MHz ceramic oscillation mode • FmX'tal=32.768kHz crystal oscillation mode • System clock set to 12MHz side • Internal RC oscillation stopped. • Frequency variable RC oscillation stopped. • 1/1 frequency division ratio 	4.5 to 5.5		3.2	8.5	mA
	IDDHALT(2)		<ul style="list-style-type: none"> • HALT mode • FmCF=8MHz ceramic oscillation mode • FmX'tal=32.768kHz crystal oscillation mode • System clock set to 8MHz side • Internal RC oscillation stopped. • Frequency variable RC oscillation stopped. • 1/1 frequency division ratio 	3.0 to 3.6		1.9	4.4	
	IDDHALT(3)		<ul style="list-style-type: none"> • HALT mode • FmCF=8MHz ceramic oscillation mode • FmX'tal=32.768kHz crystal oscillation mode • System clock set to 8MHz side • Internal RC oscillation stopped. • Frequency variable RC oscillation stopped. • 1/1 frequency division ratio 	4.5 to 5.5		2.3	6.2	
	IDDHALT(4)		<ul style="list-style-type: none"> • HALT mode • FmCF=4MHz ceramic oscillation mode • FmX'tal=32.768kHz crystal oscillation mode • System clock set to 4MHz side • Internal RC oscillation stopped. • Frequency variable RC oscillation stopped. • 1/1 frequency division ratio 	3.0 to 3.6		1.4	3.1	
	IDDHALT(5)		<ul style="list-style-type: none"> • HALT mode • FmCF=4MHz ceramic oscillation mode • FmX'tal=32.768kHz crystal oscillation mode • System clock set to 4MHz side • Internal RC oscillation stopped. • Frequency variable RC oscillation stopped. • 1/2 frequency division ratio 	2.5 to 3.0		1.0	2.5	
	IDDHALT(6)		<ul style="list-style-type: none"> • HALT mode • FmCF=0Hz (oscillation stopped) • FmX'tal=32.768kHz crystal oscillation mode • System clock set to internal RC oscillation • Internal RC oscillation stopped. • Frequency variable RC oscillation stopped. • 1/2 frequency division ratio 	4.5 to 5.5		1.4	3.9	
	IDDHALT(7)		<ul style="list-style-type: none"> • HALT mode • FmCF=0Hz (oscillation stopped) • FmX'tal=32.768kHz crystal oscillation mode • System clock set to 4MHz side • Internal RC oscillation stopped. • Frequency variable RC oscillation stopped. • 1/2 frequency division ratio 	3.0 to 3.6		0.8	1.8	
	IDDHALT(8)		<ul style="list-style-type: none"> • HALT mode • FmCF=0Hz (oscillation stopped) • FmX'tal=32.768kHz crystal oscillation mode • System clock set to 4MHz side • Internal RC oscillation stopped. • Frequency variable RC oscillation stopped. • 1/2 frequency division ratio 	2.2 to 3.0		0.6	1.3	
	IDDHALT(9)		<ul style="list-style-type: none"> • HALT mode • FmCF=0Hz (oscillation stopped) • FmX'tal=32.768kHz crystal oscillation mode • System clock set to 10MHz with frequency variable RC oscillation • Internal RC oscillation stopped. • Frequency variable RC oscillation stopped. • 1/2 frequency division ratio 	4.5 to 5.5		0.3	1.3	
	IDDHALT(10)		<ul style="list-style-type: none"> • HALT mode • FmCF=0Hz (oscillation stopped) • FmX'tal=32.768kHz crystal oscillation mode • System clock set to 10MHz with frequency variable RC oscillation • Internal RC oscillation stopped. • Frequency variable RC oscillation stopped. • 1/1 frequency division ratio 	3.0 to 3.6		0.18	0.75	
	IDDHALT(11)		<ul style="list-style-type: none"> • HALT mode • FmCF=0Hz (oscillation stopped) • FmX'tal=32.768kHz crystal oscillation mode • System clock set to 10MHz with frequency variable RC oscillation • Internal RC oscillation stopped. • Frequency variable RC oscillation stopped. • 1/1 frequency division ratio 	2.2 to 3.0		0.14	0.54	
	IDDHALT(12)		<ul style="list-style-type: none"> • HALT mode • FmCF=0Hz (oscillation stopped) • FmX'tal=32.768kHz crystal oscillation mode • System clock set to 10MHz with frequency variable RC oscillation • Internal RC oscillation stopped. • Frequency variable RC oscillation stopped. • 1/1 frequency division ratio 	4.5 to 5.5		2.7	7.1	
	IDDHALT(13)		<ul style="list-style-type: none"> • HALT mode • FmCF=0Hz (oscillation stopped) • FmX'tal=32.768kHz crystal oscillation mode • System clock set to 10MHz with frequency variable RC oscillation • Internal RC oscillation stopped. • Frequency variable RC oscillation stopped. • 1/1 frequency division ratio 	3.0 to 3.6		1.7	4.6	
	IDDHALT(14)		<ul style="list-style-type: none"> • HALT mode • FmCF=0Hz (oscillation stopped) • FmX'tal=32.768kHz crystal oscillation mode • System clock set to 4MHz with frequency variable RC oscillation • Internal RC oscillation stopped. • Frequency variable RC oscillation stopped. • 1/1 frequency division ratio 	4.5 to 5.5		1.3	3.5	
	IDDHALT(15)		<ul style="list-style-type: none"> • HALT mode • FmCF=0Hz (oscillation stopped) • FmX'tal=32.768kHz crystal oscillation mode • System clock set to 4MHz with frequency variable RC oscillation • Internal RC oscillation stopped. • Frequency variable RC oscillation stopped. • 1/1 frequency division ratio 	3.0 to 3.6		0.8	1.75	
	IDDHALT(16)		<ul style="list-style-type: none"> • HALT mode • FmCF=0Hz (oscillation stopped) • FmX'tal=32.768kHz crystal oscillation mode • System clock set to 4MHz with frequency variable RC oscillation • Internal RC oscillation stopped. • Frequency variable RC oscillation stopped. • 1/1 frequency division ratio 	2.2 to 3.0		0.6	1.2	
	IDDHALT(17)		<ul style="list-style-type: none"> • HALT mode • FmCF=0Hz (oscillation stopped) • FmX'tal=32.768kHz crystal oscillation mode • System clock set to 32.768kHz side • Internal RC oscillation stopped. • Frequency variable RC oscillation stopped. • 1/2 frequency division ratio 	4.5 to 5.5		19.0	100.3	
	IDDHALT(18)		<ul style="list-style-type: none"> • HALT mode • FmCF=0Hz (oscillation stopped) • FmX'tal=32.768kHz crystal oscillation mode • System clock set to 32.768kHz side • Internal RC oscillation stopped. • Frequency variable RC oscillation stopped. • 1/2 frequency division ratio 	3.0 to 3.6		7.9	38.0	
	IDDHALT(19)		<ul style="list-style-type: none"> • HALT mode • FmCF=0Hz (oscillation stopped) • FmX'tal=32.768kHz crystal oscillation mode • System clock set to 32.768kHz side • Internal RC oscillation stopped. • Frequency variable RC oscillation stopped. • 1/2 frequency division ratio 	2.2 to 3.0		4.9	26.0	
HOLD mode consumption current	IDDHOLD(1)	V _{DD1}	<ul style="list-style-type: none"> • HOLD mode • CF1=V_{DD} or open (External clock mode) 	4.5 to 5.5		0.14	32.5	μA
	IDDHOLD(2)		<ul style="list-style-type: none"> • HOLD mode • CF1=V_{DD} or open (External clock mode) 	3.0 to 3.6		0.03	12.0	
	IDDHOLD(3)		<ul style="list-style-type: none"> • HOLD mode • CF1=V_{DD} or open (External clock mode) 	2.2 to 3.0		0.01	14.0	
Timer HOLD mode consumption current	IDDHOLD(4)		<ul style="list-style-type: none"> • Timer HOLD mode • CF1=V_{DD} or open (External clock mode) • FmX'tal=32.768kHz crystal oscillation mode 	4.5 to 5.5		15.5	58.0	
	IDDHOLD(5)		<ul style="list-style-type: none"> • Timer HOLD mode • CF1=V_{DD} or open (External clock mode) • FmX'tal=32.768kHz crystal oscillation mode 	3.0 to 3.6		6.3	32.0	
	IDDHOLD(6)		<ul style="list-style-type: none"> • Timer HOLD mode • CF1=V_{DD} or open (External clock mode) • FmX'tal=32.768kHz crystal oscillation mode 	2.2 to 3.0		3.6	20.0	

Note 7-1: The consumption current value includes none of the currents that flow into the output Tr and internal pull-up resistors.

LC87F7DC8A

F-ROM Write Characteristics at Ta = +10°C to +55°C, VSS1 = VSS2 = VSS3 = 0V

Parameter	Symbol	Pin/Remarks	Conditions	Specification				
				V _{DD} [V]	min	typ	max	unit
Onboard programming current	I _{DDFW} (1)	V _{DD} 1	<ul style="list-style-type: none"> 128-byte programming Erasing current included 	3.0 to 5.5		25	40	mA
Programming time	t _{FW} (1)		<ul style="list-style-type: none"> 128-byte programming Erasing current included Time for setting up 128-byte data is excluded. 	3.0 to 5.5		22.5	45	ms

UART (Full Duplex) Operating Conditions at Ta = -40 to +85°C, VSS1 = VSS2 = VSS3 = 0V

Parameter	Symbol	Pin/Remarks	Conditions	Specification				
				V _{DD} [V]	min	typ	max	unit
Transfer rate	UBR	UTX(P32), URX(P33)		2.2 to 5.5	16/3		8192/3	tCYC

Data length: 7/8/9 bits (LSB first)

Stop bits: 1 bit (2-bit in continuous data transmission)

Parity bits: None

Example of 8-bit Data Transmission Mode Processing (Transmit Data=55H)

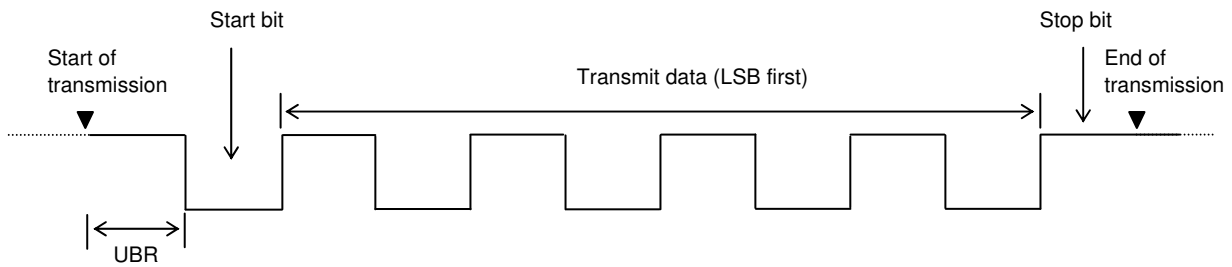

Example of 8-bit Data Reception Mode Processing (Receive Data=55H)

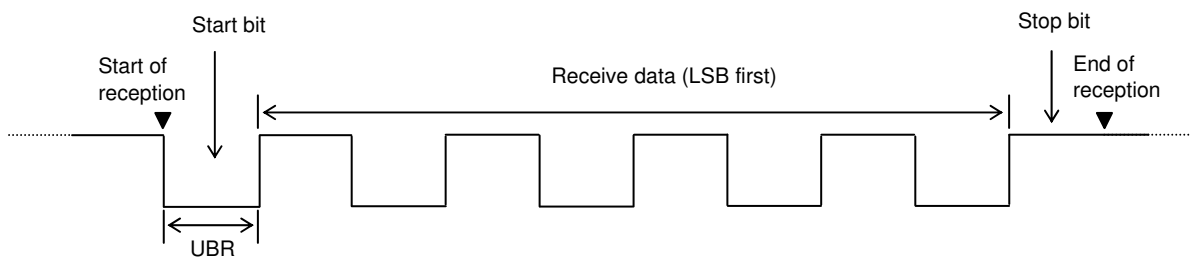

Characteristics of a Sample Main System Clock Oscillation Circuit

Given below are the characteristics of a sample main system clock oscillation circuit that are measured using a Our designated oscillation characteristics evaluation board and external components with circuit constant values with which the oscillator vendor confirmed normal and stable oscillation.

Table 1 Characteristics of a Sample Main System Clock Oscillator Circuit with a Ceramic Oscillator

Nominal Frequency	Vendor Name	Oscillator Name	Circuit Constant				Operating Voltage Range [V]	Oscillation Stabilization Time		Remarks
			C1 [pF]	C2 [pF]	Rf1 [Ω]	Rd1 [Ω]		typ [ms]	max [ms]	
12MHz	MURATA	CSTCE12M0G52-R0	(10)	(10)	Open				Values shown in parentheses are capacitance included in the oscillator	
8MHz	MURATA	CSTCE8M00G52-R0	(10)	(10)	Open				Values shown in parentheses are capacitance included in the oscillator	
		CSTLS8M00G52-R0	(15)	(15)	Open					
4MHz	MURATA	CSTCR4M00F53-R0	(15)	(15)	Open				Values shown in parentheses are capacitance included in the oscillator	
		CSTLS4M0053-B0	(15)	(15)	Open					

The oscillation stabilization time refers to the time interval that is required for the oscillation to get stabilized after VDD goes above the operating voltage lower limit (see Figure 4).

Characteristics of a Sample Subsystem Clock Oscillator Circuit

Given below are the characteristics of a sample subsystem clock oscillation circuit that are measured using a Our designated oscillation characteristics evaluation board and external components with circuit constant values with which the oscillator vendor confirmed normal and stable oscillation.

Table 2 Characteristics of a Sample Subsystem Clock Oscillator Circuit with a Crystal Oscillator

Nominal Frequency	Vendor Name	Oscillator Name	Circuit Constant				Operating Voltage Range [V]	Oscillation Stabilization Time		Remarks
			C3 [pF]	C4 [pF]	Rf2 [Ω]	Rd2 [Ω]		typ [s]	max [s]	
32.768kHz	EPSON TOYOCOM	MC-306								

The oscillation stabilization time refers to the time interval that is required for the oscillation to get stabilized after the instruction for starting the subclock oscillation circuit is executed and to the time interval that is required for the oscillation to get stabilized after the HOLD mode is reset (see Figure 4).

Note: The components that are involved in oscillation should be placed as close to the IC and to one another as possible because they are vulnerable to the influences of the circuit pattern.

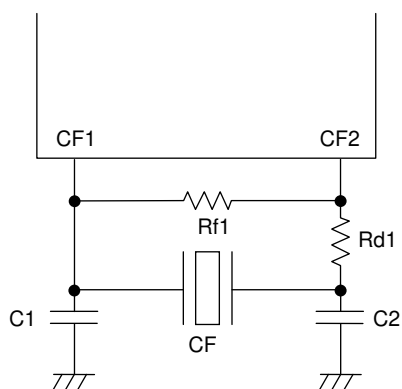

Figure 1 CF Oscillator Circuit

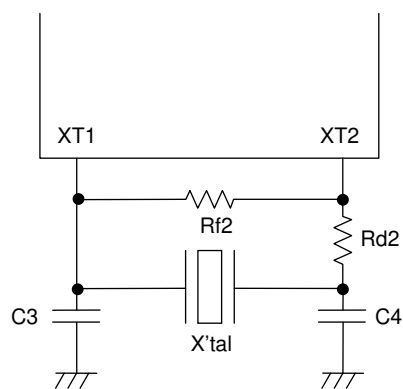

Figure 2 XT Oscillator Circuit

LC87F7DC8A

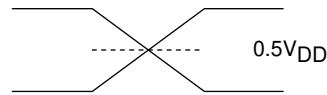
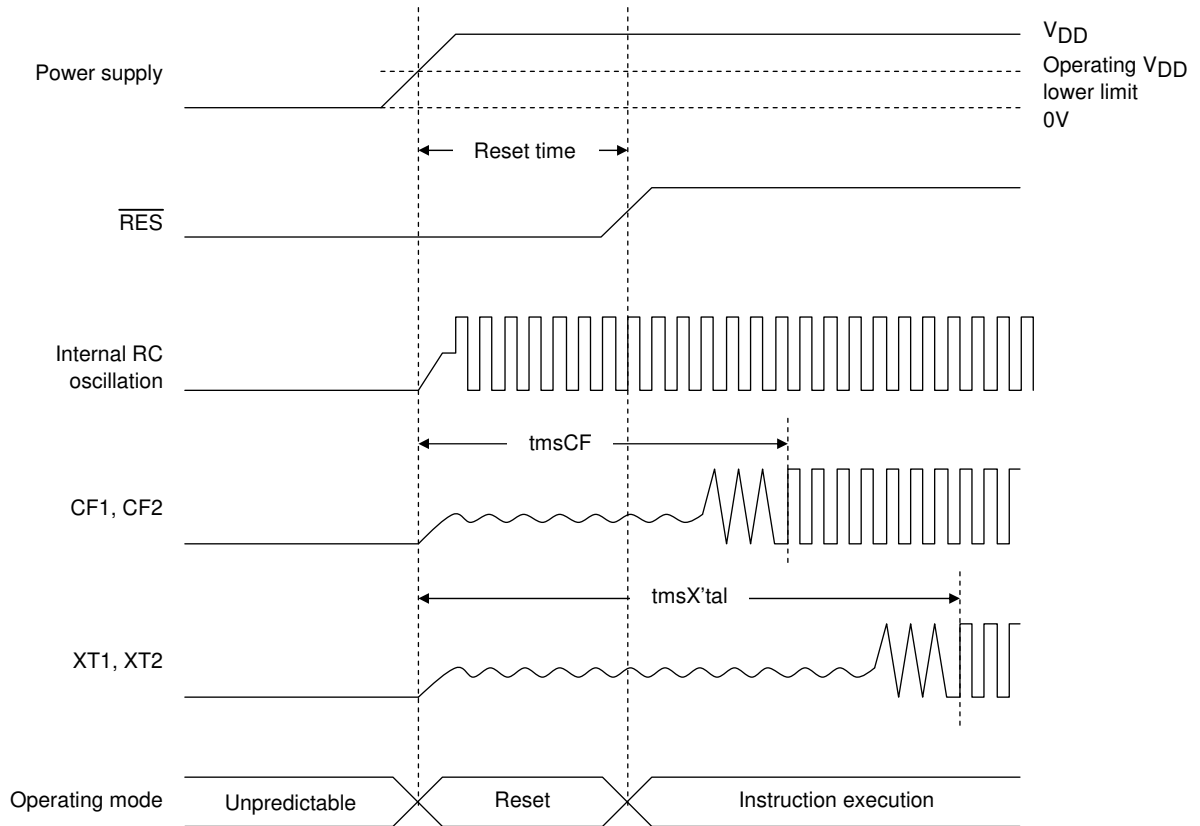
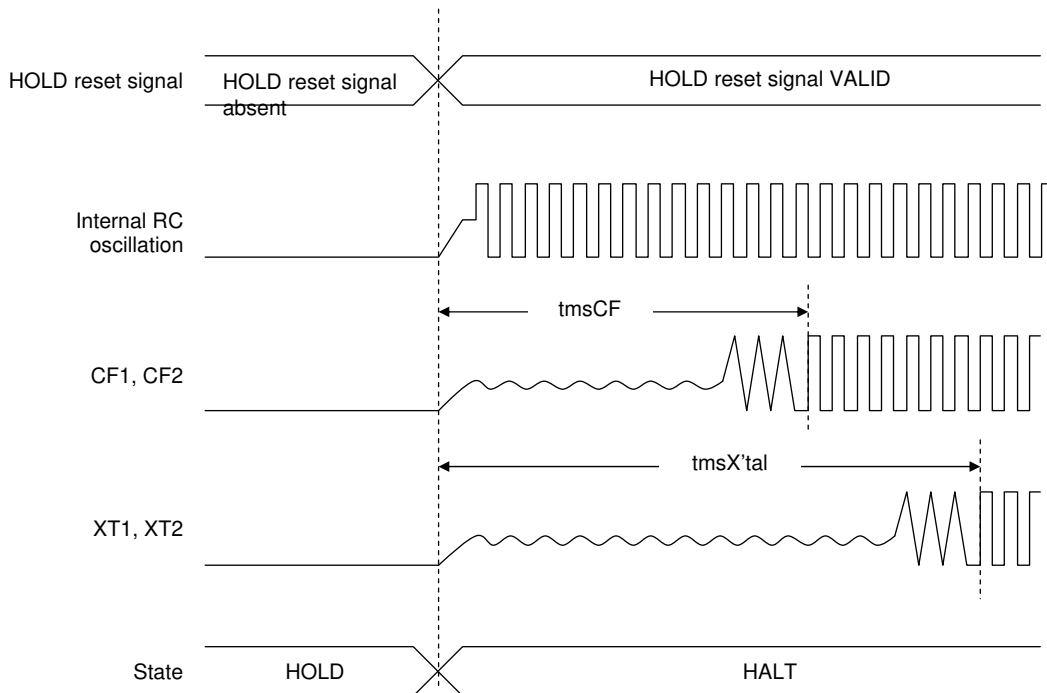

Figure 3 AC Timing Measurement Point



Reset Time and Oscillation Stabilization Time



HOLD Reset Signal and Oscillation Stabilization Time

Figure 4 Oscillation Stabilization Times

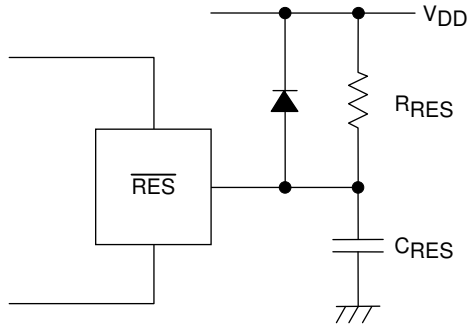

Note:
Determine the value of C_{RES} and R_{RES} so that the reset signal is present for a period of $200\mu s$ after the supply voltage goes beyond the lower limit of the IC's operating voltage.

Figure 5 Reset Circuit

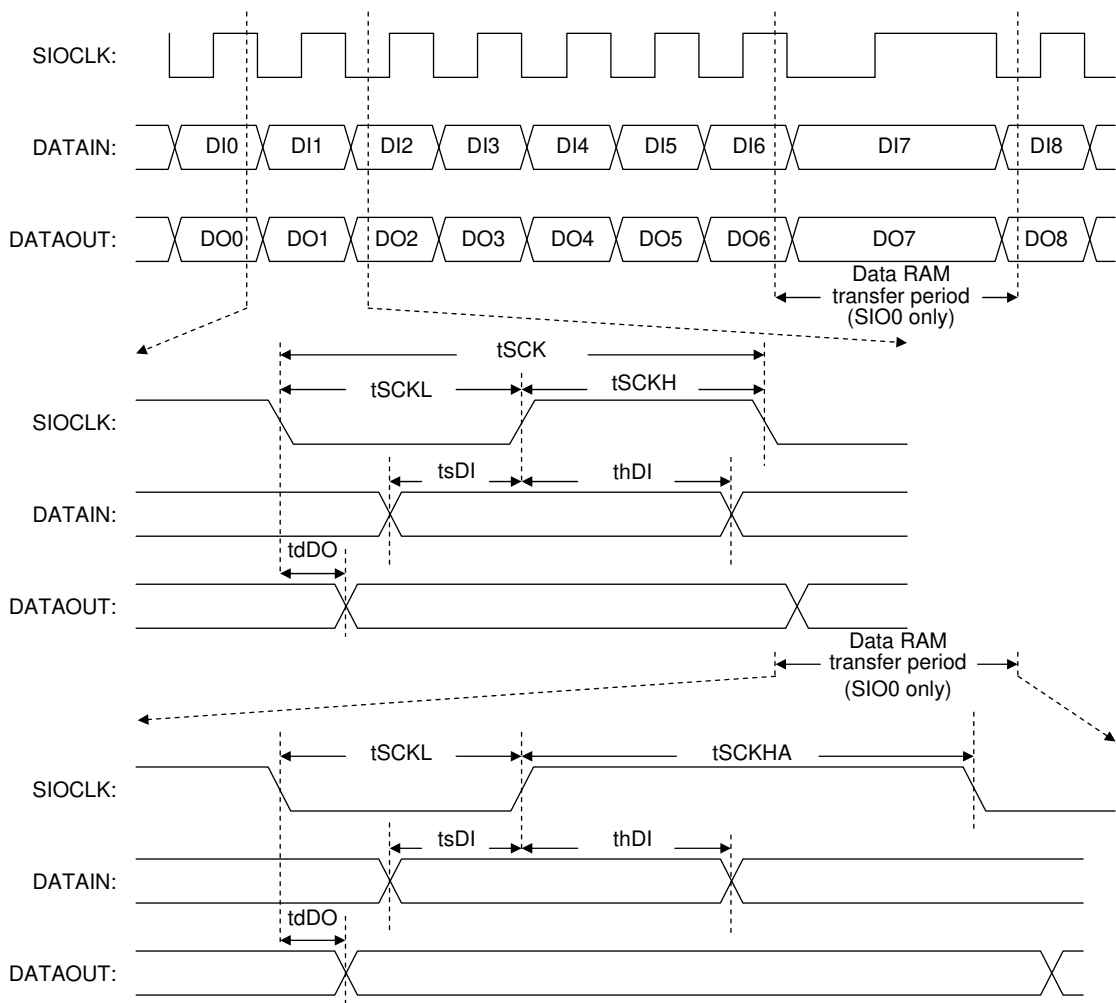

Figure 6 Serial I/O Waveforms

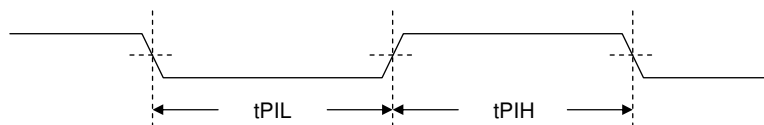

Figure 7 Pulse Input Timing Signal Waveform

LC87F7DC8A

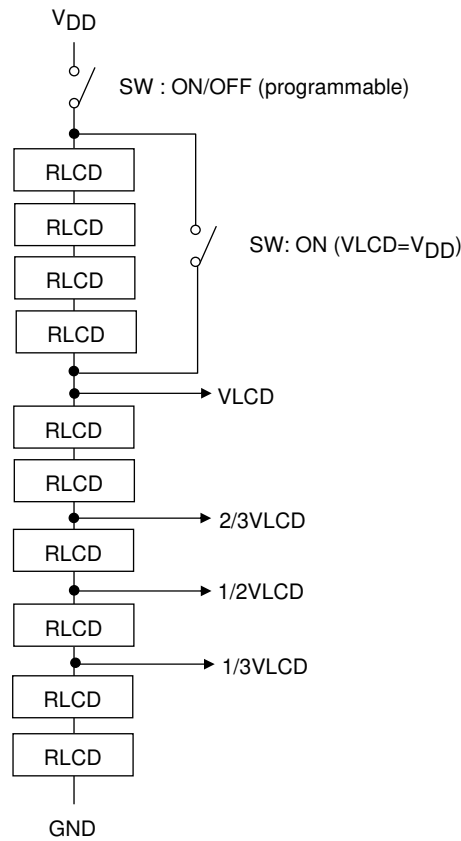

Figure 8 LCD Bias Resistor

ON Semiconductor and the ON logo are registered trademarks of Semiconductor Components Industries, LLC (SCILLC). SCILLC owns the rights to a number of patents, trademarks, copyrights, trade secrets, and other intellectual property. A listing of SCILLC's product/patent coverage may be accessed at www.onsemi.com/site/pdf/Patent-Marking.pdf. SCILLC reserves the right to make changes without further notice to any products herein. SCILLC makes no warranty, representation or guarantee regarding the suitability of its products for any particular purpose, nor does SCILLC assume any liability arising out of the application or use of any product or circuit, and specifically disclaims any and all liability, including without limitation special, consequential or incidental damages. "Typical" parameters which may be provided in SCILLC data sheets and/or specifications can and do vary in different applications and actual performance may vary over time. All operating parameters, including "Typicals" must be validated for each customer application by customer's technical experts. SCILLC does not convey any license under its patent rights nor the rights of others. SCILLC products are not designed, intended, or authorized for use as components in systems intended for surgical implant into the body, or other applications intended to support or sustain life, or for any other application in which the failure of the SCILLC product could create a situation where personal injury or death may occur. Should Buyer purchase or use SCILLC products for any such unintended or unauthorized application, Buyer shall indemnify and hold SCILLC and its officers, employees, subsidiaries, affiliates, and distributors harmless against all claims, costs, damages, and expenses, and reasonable attorney fees arising out of, directly or indirectly, any claim of personal injury or death associated with such unintended or unauthorized use, even if such claim alleges that SCILLC was negligent regarding the design or manufacture of the part. SCILLC is an Equal Opportunity/Affirmative Action Employer. This literature is subject to all applicable copyright laws and is not for resale in any manner.