

LOC	DIST	REVISIONS					
GP	00	P	LTN	DESCRIPTION	DATE	DWN	APVD
		A		RELEASED FOR PRODUCTION	07MAR2016	TX	SH

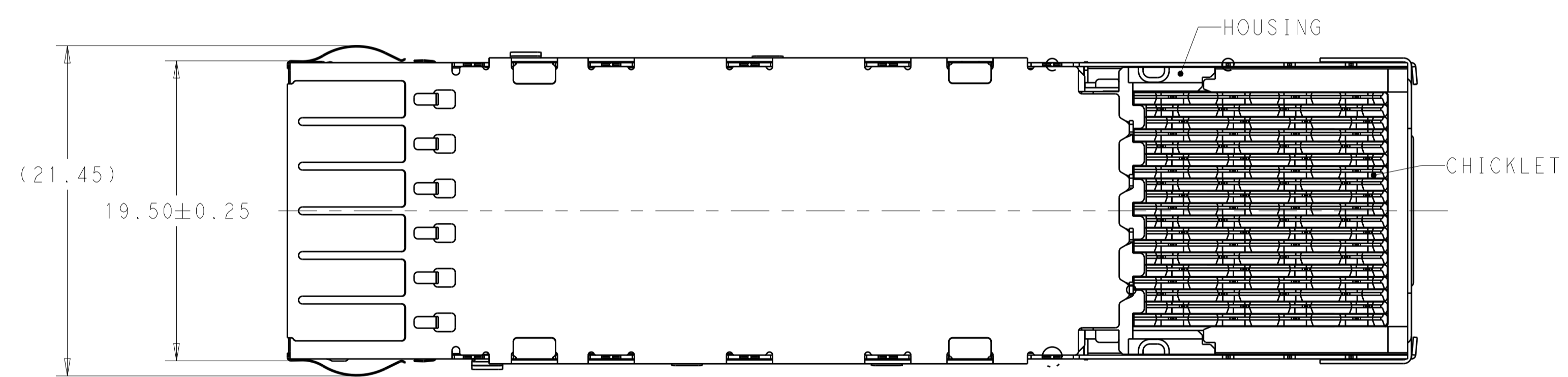
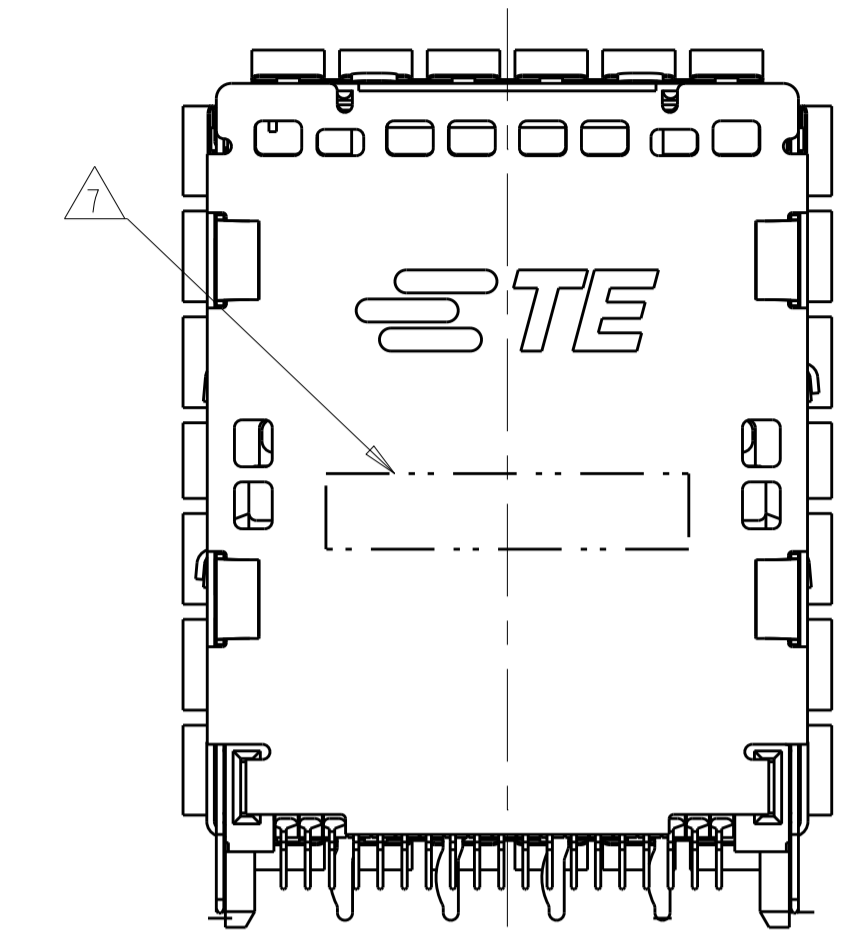
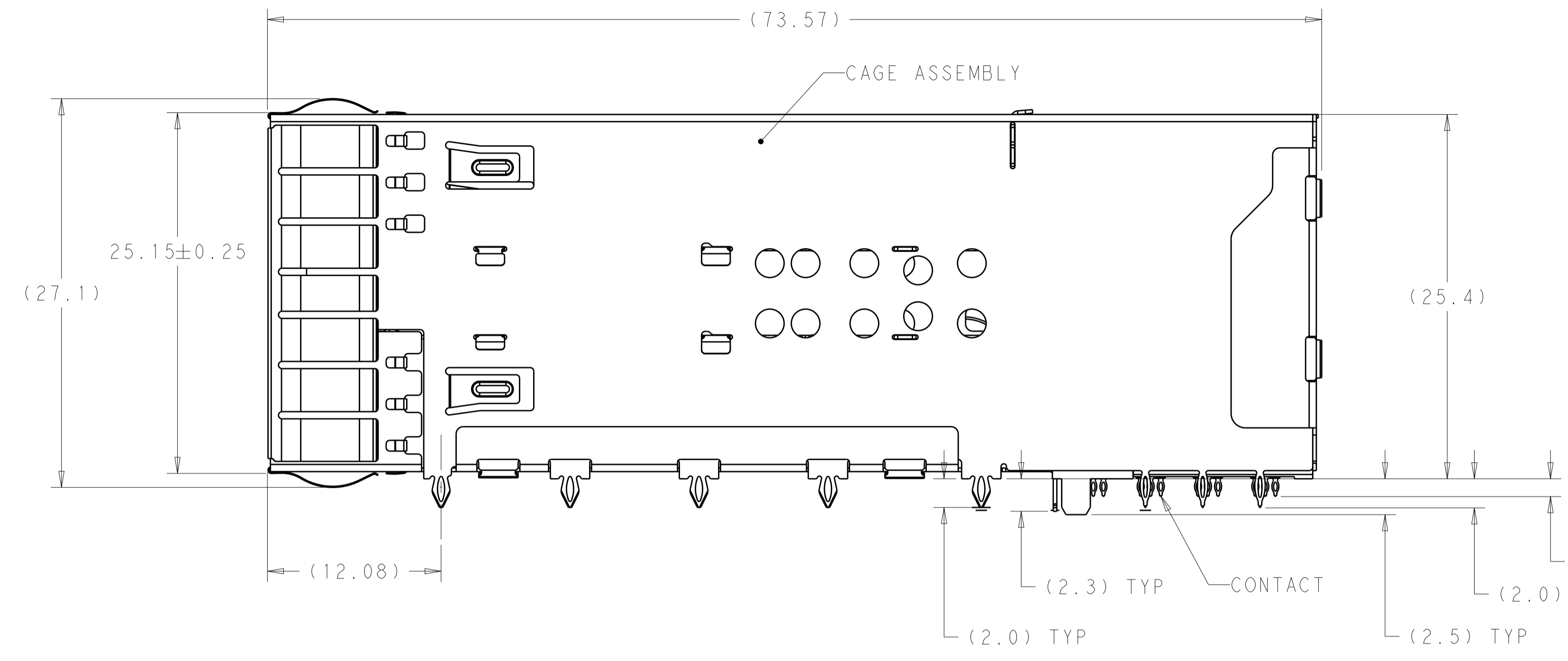
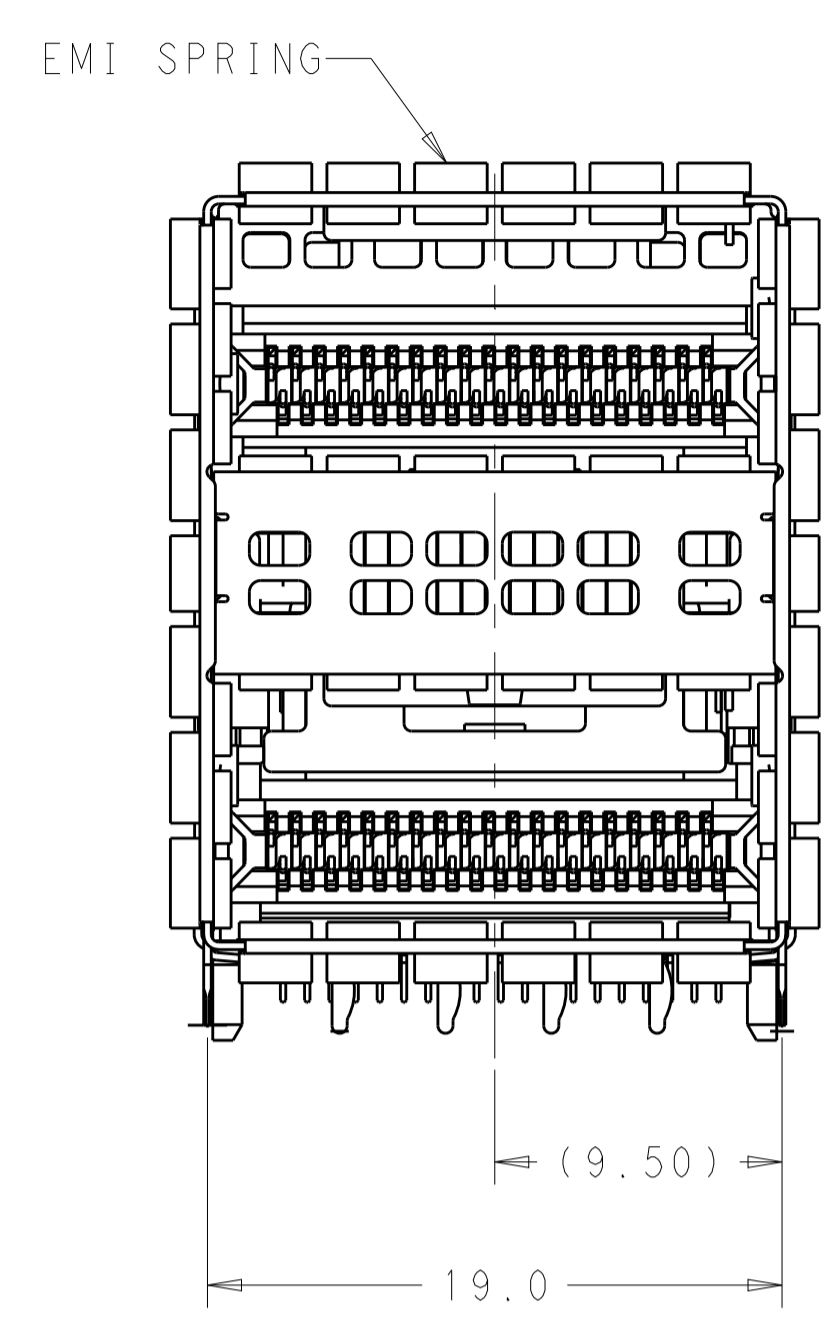

1. MATERIALS:
 CAGE ASSEMBLY- NICKEL SILVER ALLOY PER ASTM B 122.
 EMI SPRING- COPPER ALLOY, NICKEL PLATED.
 HOUSING- POLYESTER LCP WITH 94V-0.
 CHICKLET- POLYESTER LCP WITH 94V-0.
 CONTACT- COPPER ALLOY.
 LIGHTPIPE- POLYCARBONATE WITH 94V-0.

- ② CONTACT FINISH: 0.76µm GOLD ON MATING END, 1.25µm MATT TIN ON SOLDER TAIL, ALL OVER 1.27µm NICKEL.
 ③ DATUM AND BASIC DIMENSION ESTABLISHED BY CUSTOMER.
 4. MINIMUM PCB THICKNESS OF 1.57.
 ⑤ THE ENTIRE AREA OF THE CONNECTOR FOOTPRINT, INDICATED BY THE DASHED LINE, TO BE CONSIDERED THE KEEPOUT AREA FOR COMPONENTS.
 ⑥ CROSS-HATCHED AREAS REPRESENT ZONES ON THE PCB THAT COME IN CONTACT WITH OR BE IN CLOSE PROXIMITY TO THE PLASTIC HOUSING OR THE CONNECTOR CAGE. INDICATED AREAS TO BE CONSIDERED TRACE FREE.
 ⑦ PART NUMBER AND DATE CODE MADE IN APPROXIMATE AREA SHOWN.
 ⑧ THESE HOLES ARE OPTIONAL WHEN PINS ON BACK OF GAGE ARE REMOVED.
 ⑨ CONTACT FINISH: 0.08µm MINIMUM GOLD OVER 0.68µm PALLADIUM-NICKEL ON MATING END, 1.25µm MATT TIN ON SOLDER TAIL, ALL OVER 1.27µm NICKEL.
 ⑩ HATCHED ARE IS PLACEMENT ZONE FOR LED. LED SHOULD BE CENTERED WITHIN ZONE. RECOMMEND 0805 PACKAGE.

CONTACT FINISH	DESCRIPTION	PART NUMBER
⑨	LEFT INDICATOR DOWN	2227666-6
⑨	LEFT INDICATOR UP	2227666-5
⑨	NO LIGHTPIPE	2227666-4
②	LEFT INDICATOR DOWN	2227666-3
②	LEFT INDICATOR UP	2227666-2
②	NO LIGHTPIPE	2227666-1

THIS DRAWING IS A CONTROLLED DOCUMENT.

DIMENSIONS:	TOLERANCES UNLESS OTHERWISE SPECIFIED:	DWN: M. SHIRK 16JAN2013	NAME: STE TE Connectivity
mm	0 PLC ±0.25 1 PLC ±0.15 2 PLC ±0.15 3 PLC ±0.15 4 PLC ±0.15	CHK: D. SZCZESNY 16JAN2013	PRODUCT SPEC: 108-60102
ANGLES	FINISH	APVD: -	APPLICATION SPEC: 114-60015
MATERIAL: SEE NOTE 1		SIZE: 114-60015	RESTRICTED TO: A100779C=2227666
		WEIGHT: -	CUSTOMER DRAWING
		SCALE: 4:1	SHEET 1 OF 4 REV A

LOC		DIST		REVISIONS			
P	LTN	DESCRIPTION	DATE	DWN	APVD		
-	-	SEE SHEET 1	-	-	-		

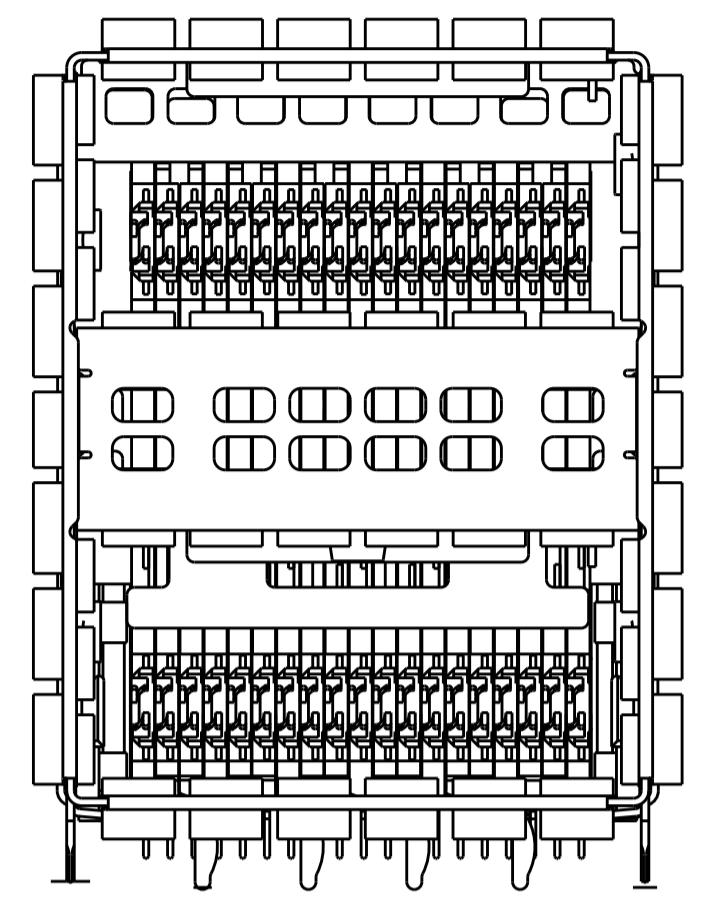

2227666-1 / 2227666-4
NO LIGHTPIPE IN ASSEMBLY

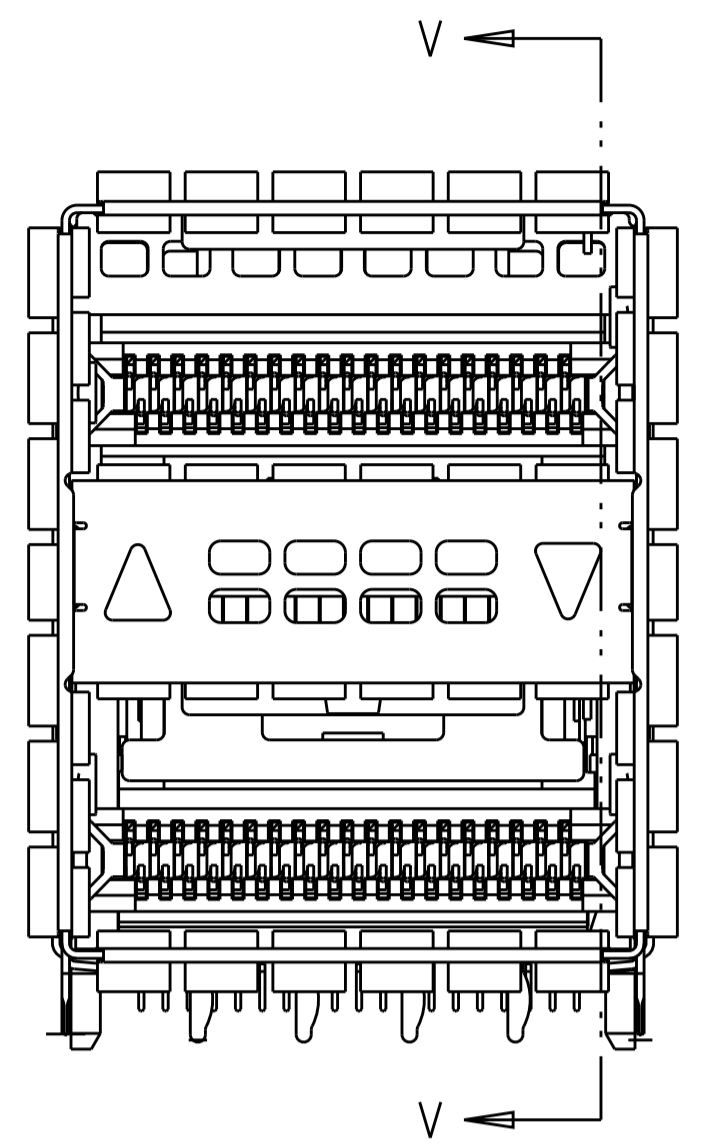

2227666-2 / 2227666-5
LEFT LIGHTPIPE INDICATOR
POINTING TO UPPER PORT

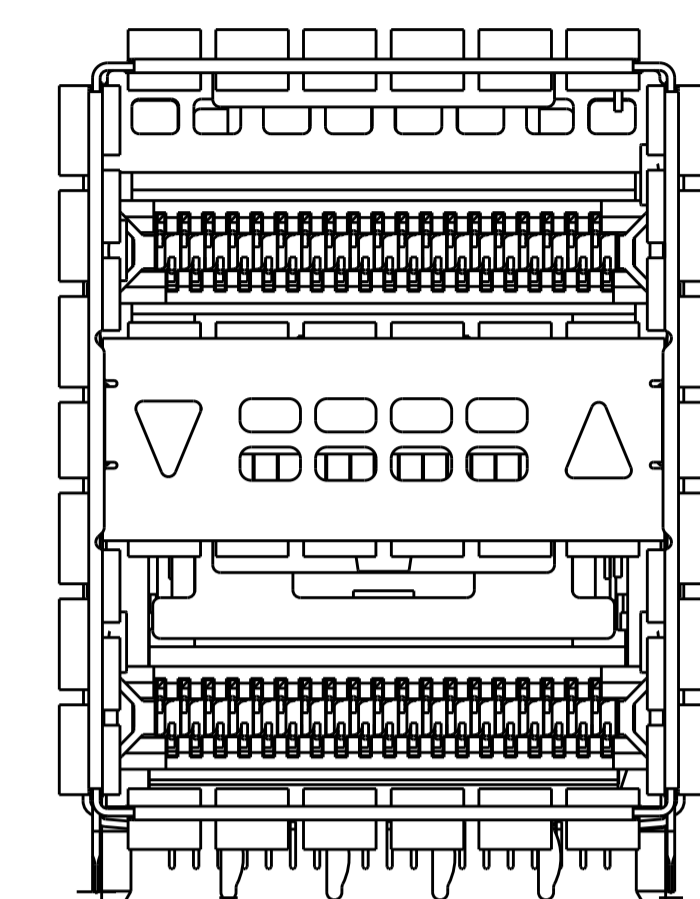

2227666-3 / 2227666-6
LEFT LIGHTPIPE INDICATOR
POINTING TO LOWER PORT

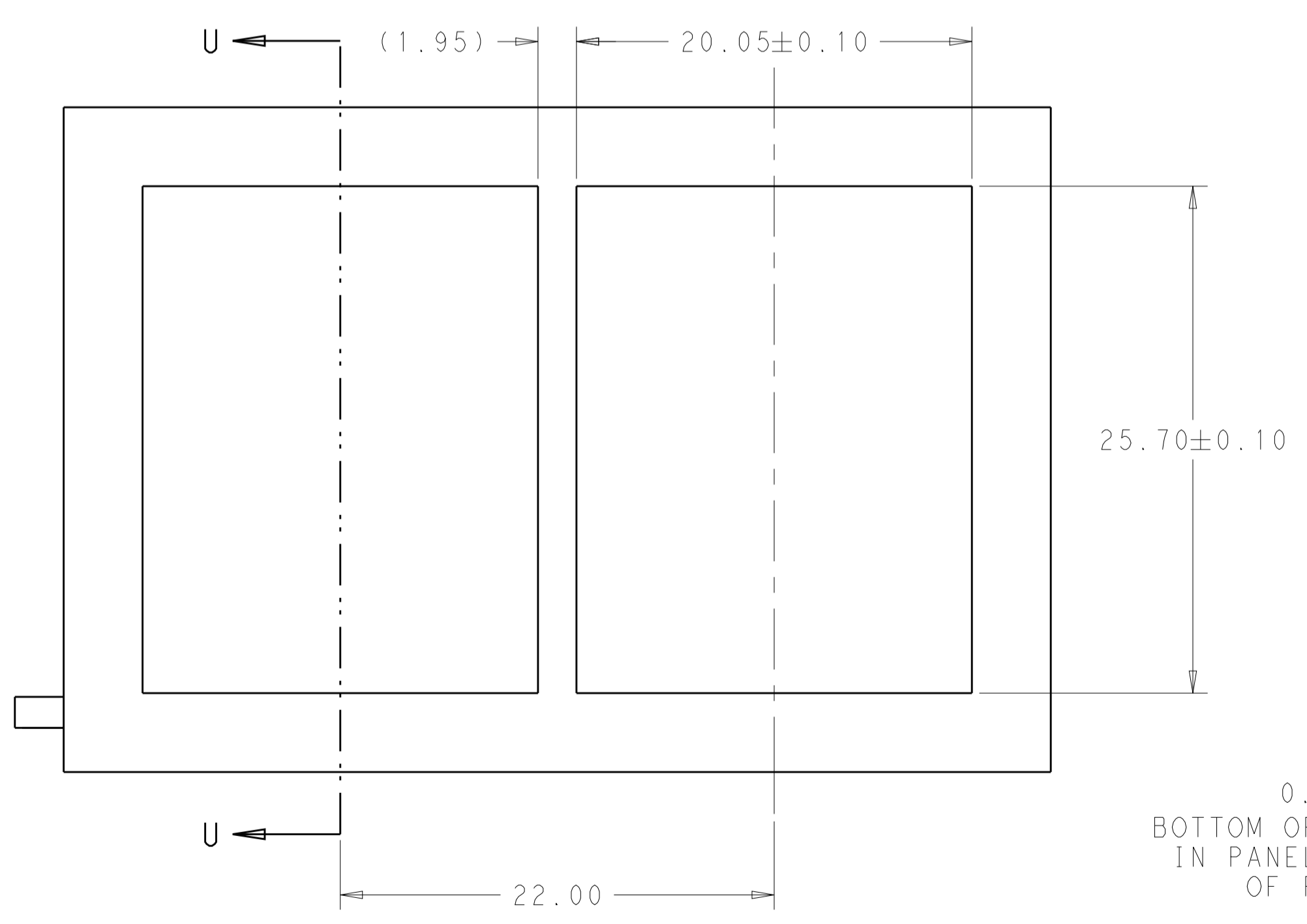

RECOMMENDED PANEL CUTOUT
AND PC BOARD, PANEL POSITION

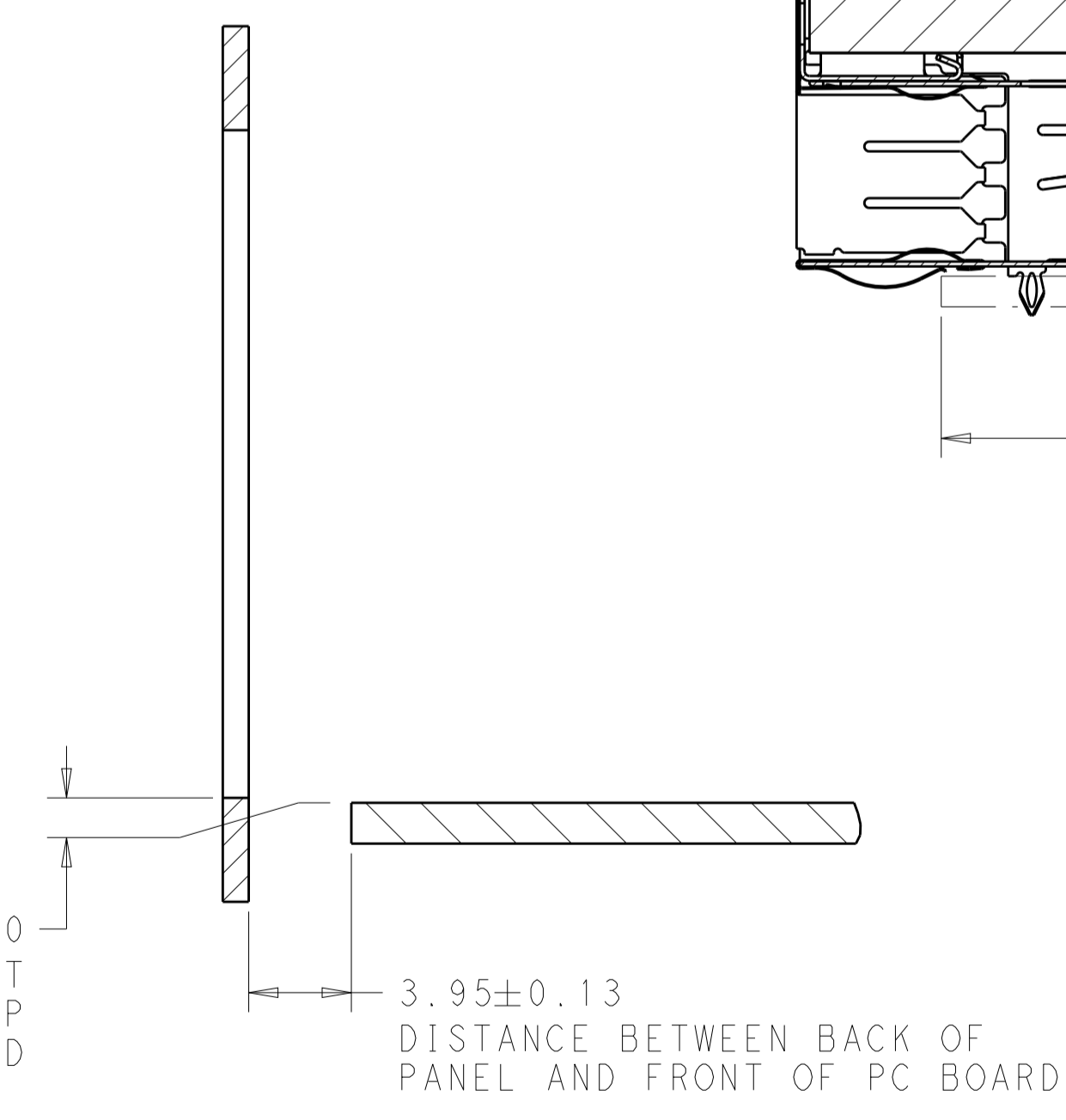

SECTION U-U

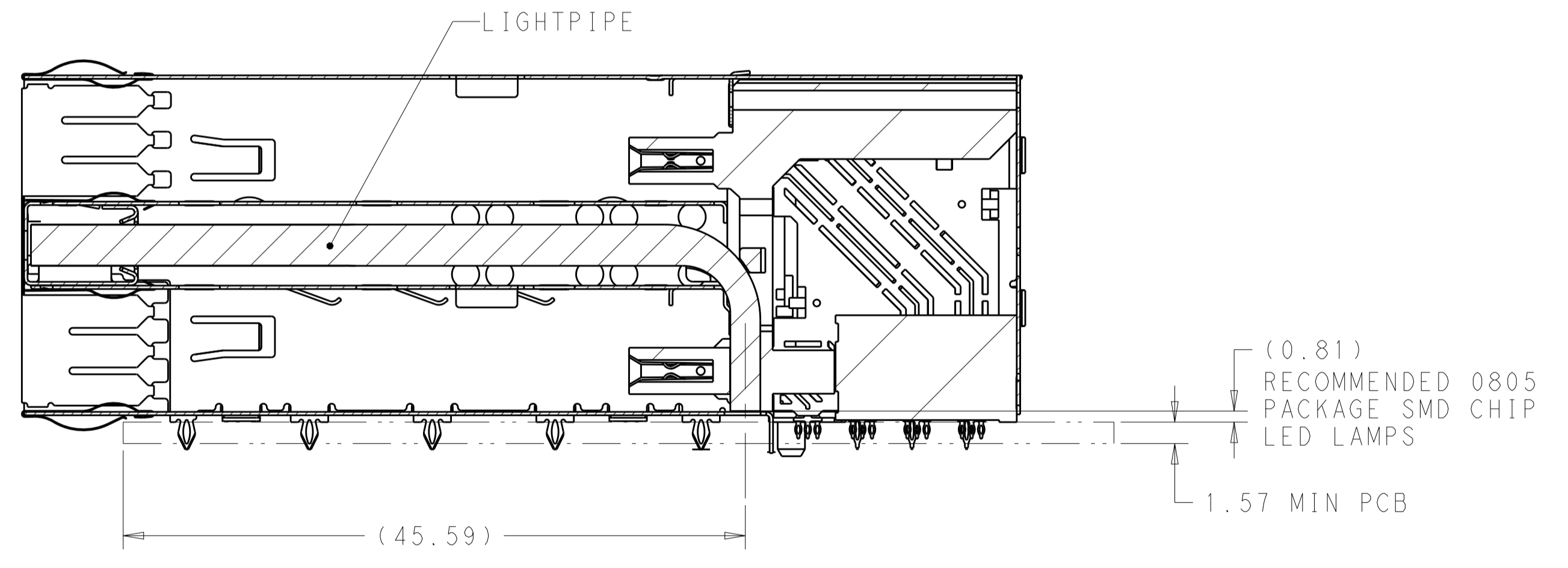

SECTION V-V
SCALE 3:1

THIS DRAWING IS A CONTROLLED DOCUMENT.		DWN: M. SHIRK 16JAN2013	TE Connectivity
DIMENSIONS: mm		CHK: D. SZCZESNY 16JAN2013	
TOLERANCES UNLESS OTHERWISE SPECIFIED:		APVD: -	NAME: CAGE AND CONNECTOR ASSEMBLY, WITH EMI SPRING FINGERS, THRU BEZEL, 2X1, ZQSFP+ STACKED
0 PLC ±	1 PLC ±0.25	PRODUCT SPEC: 108-60102	SIZE: 114-60015
2 PLC ±	3 PLC ±0.15	APPLICATION SPEC: -	WEIGHT: -
4 PLC ±	ANGLES ±	RESTRICTED TO: -	SCALE: 4:1
MATERIAL: -	FINISH: -	Customer Drawing	SHEET 2 OF 4
SEE NOTE 1		A100779C=2227666	REV A

LOC	DIST	REVISIONS			
P	LTH	DESCRIPTION	DATE	DWN	APVD
-	-	SEE SHEET 1	-	-	-

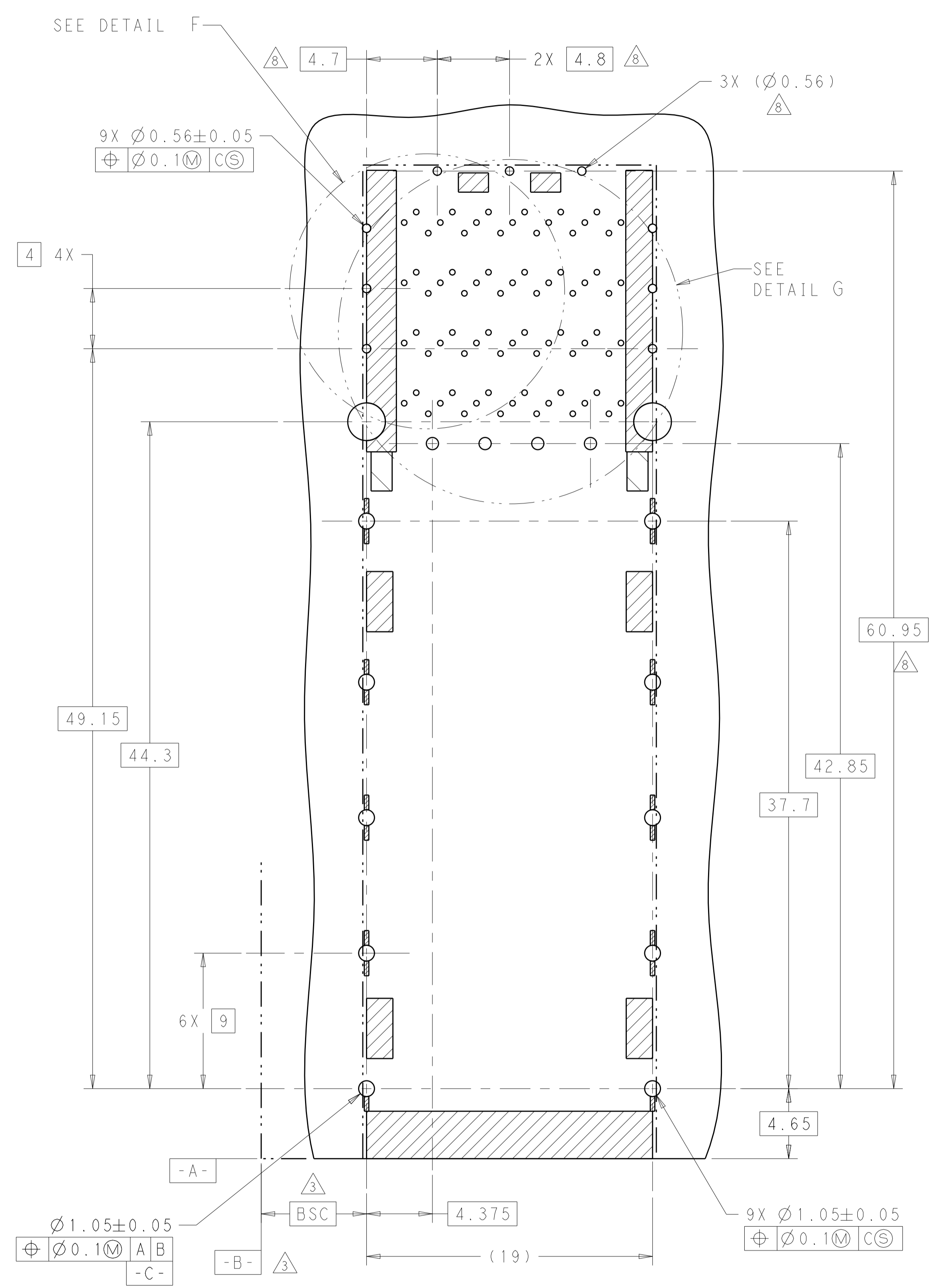

RECOMMENDED PC BOARD LAYOUT
 COMPONENT SIDE OF BOARD
 SCALE 5:1
 (PCB TOLERANCE: ±0.05)

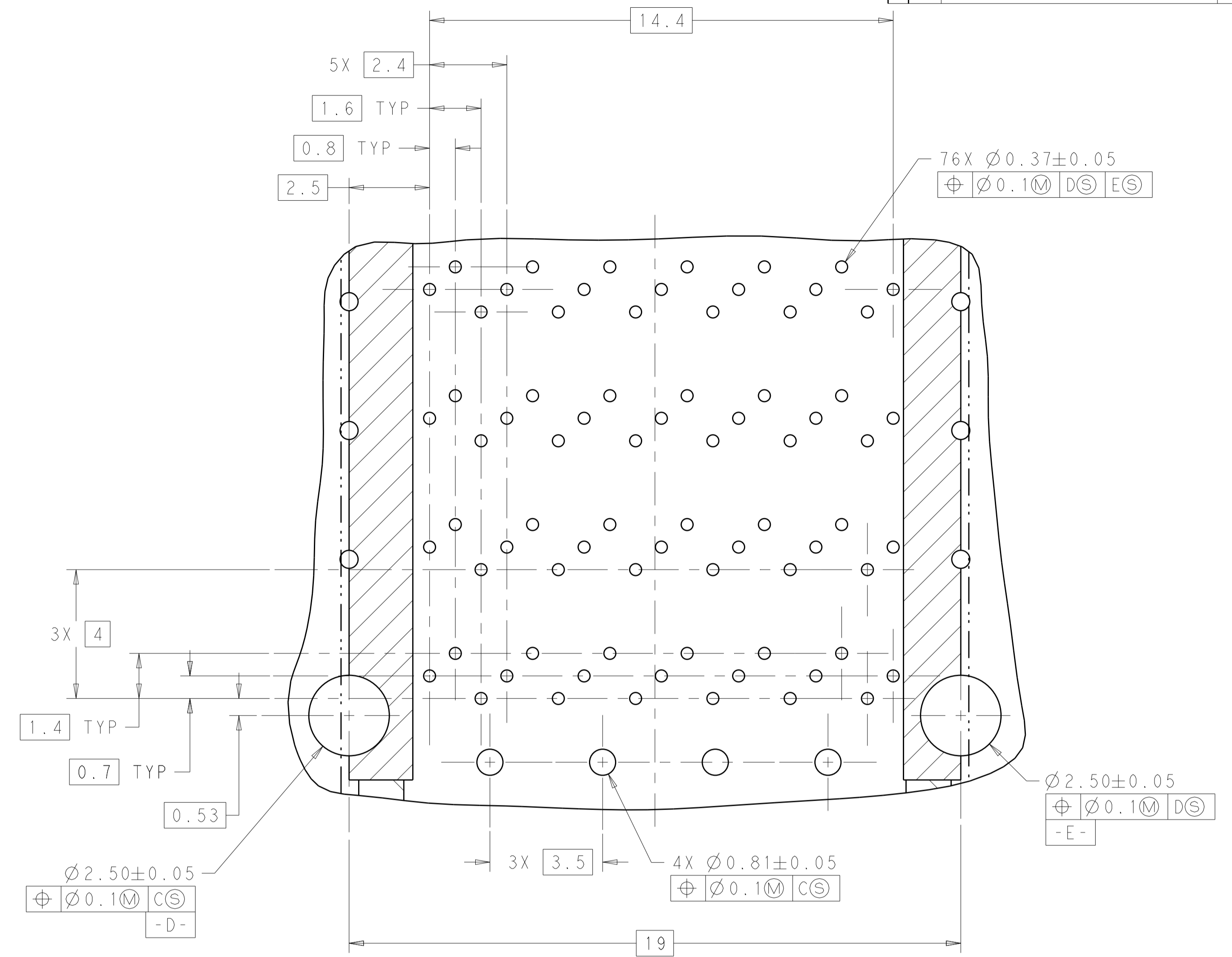

DETAIL G
 SCALE 10:1

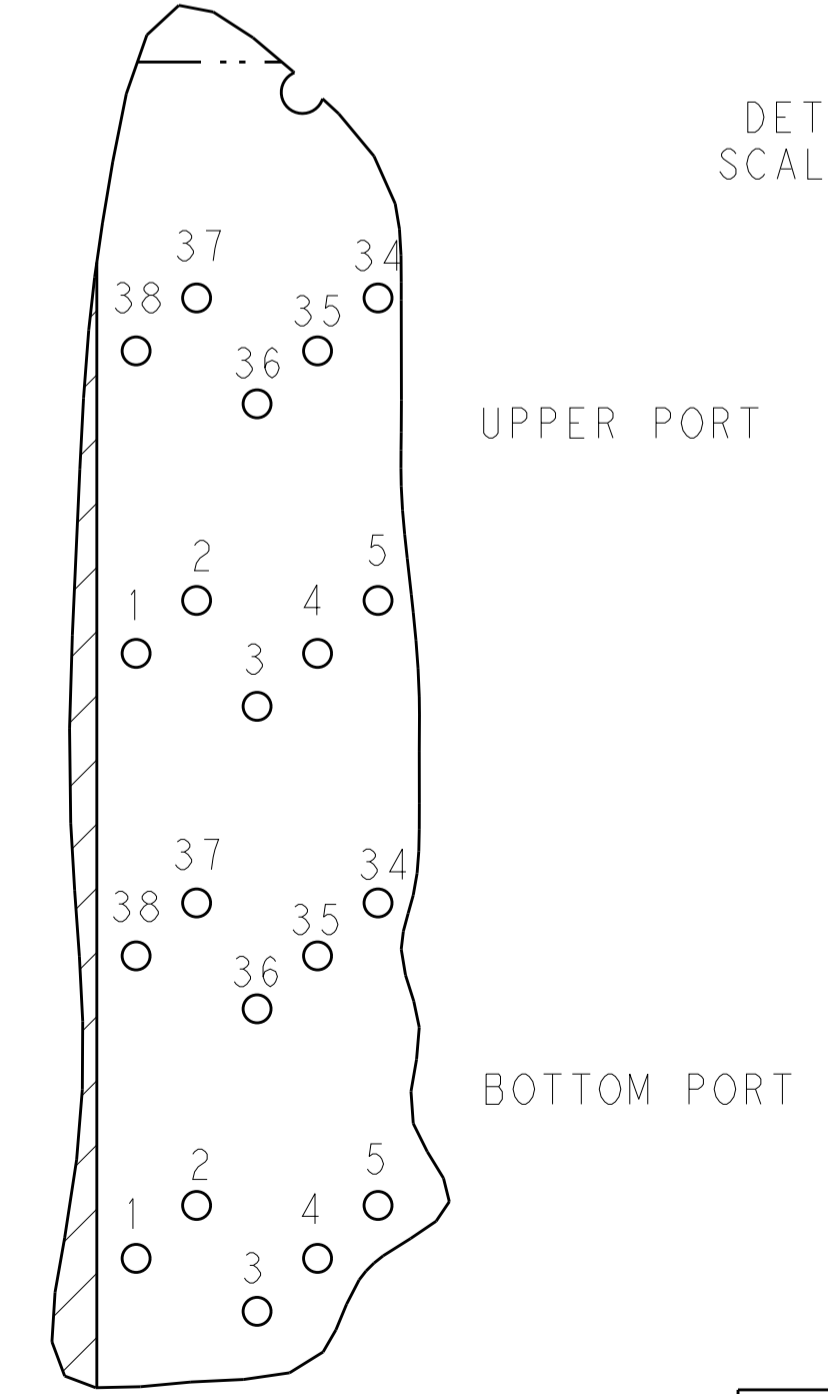

DETAIL F
 SCALE 10:1
 PIN ASSIGNMENTS

THIS DRAWING IS A CONTROLLED DOCUMENT.		DWN: M. SHIRK 16JAN2013	TE Connectivity
DIMENSIONS: mm		CHK: D. SZCZESNY 16JAN2013	
TOLERANCES UNLESS OTHERWISE SPECIFIED:		APVD: -	NAME: CAGE AND CONNECTOR ASSEMBLY, WITH EMI SPRING FINGERS, THRU BEZEL, 2X1, ZQSFP+ STACKED
0 PLC ±0.25		PRODUCT SPEC: 108-60102	SIZE: A1
1 PLC ±0.15		APPLICATION SPEC: 114-60015	CAGE CODE: C=2227666
2 PLC ±0.15		WEIGHT: -	RESTRICTED TO: -
3 PLC ±0.15		CUSTOMER DRAWING	SCALE: 4:1 SHEET: 3 OF 4 REV: A
4 PLC ±0.15			
ANGLES ±0.15			
MATERIAL: -			
FINISH: -			
SEE NOTE 1			

LOC		DIST		REVISIONS			
P	LTN	DESCRIPTION	DATE	DWN	APVD		
-	-	SEE SHEET 1	-	-	-		

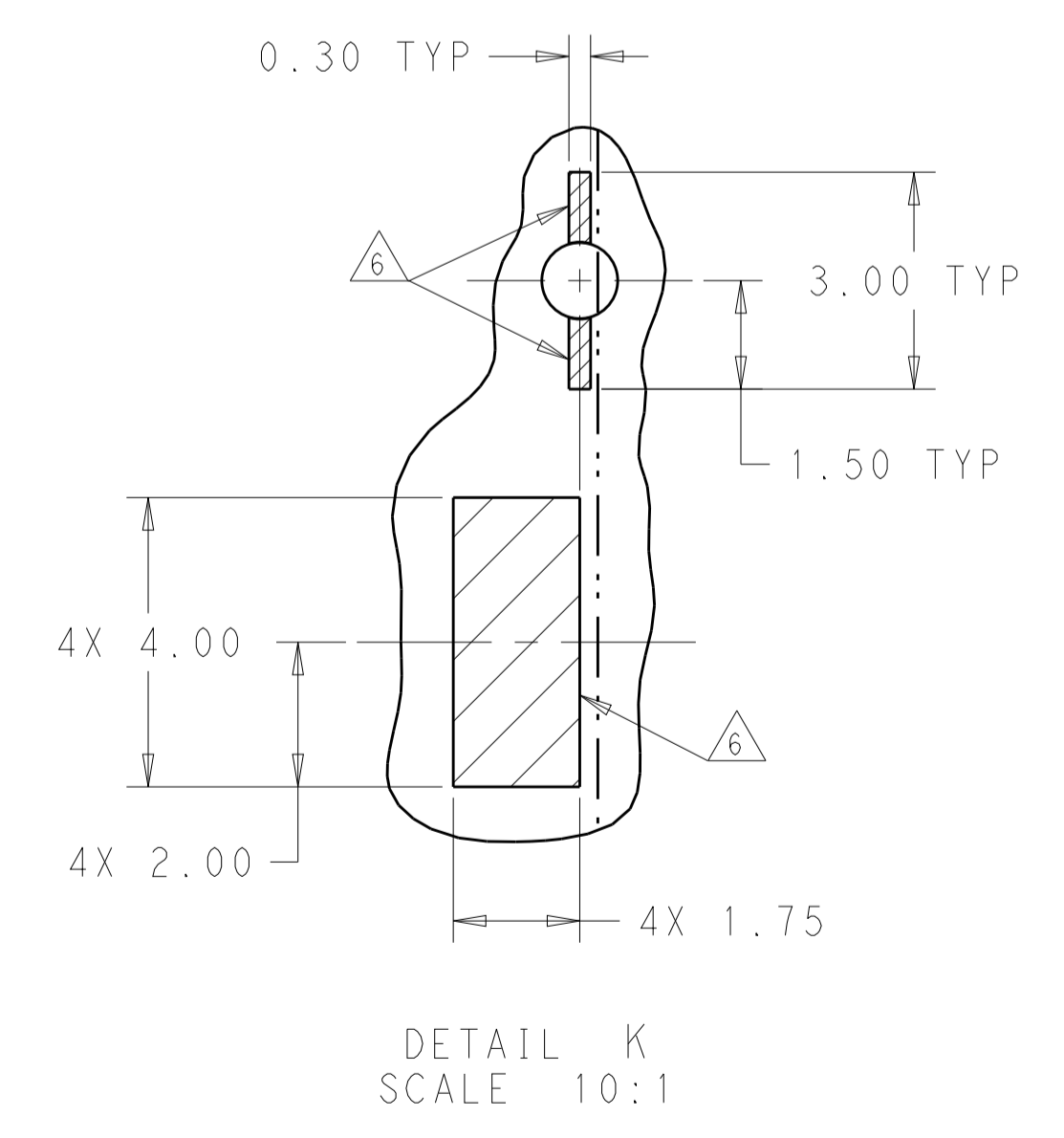
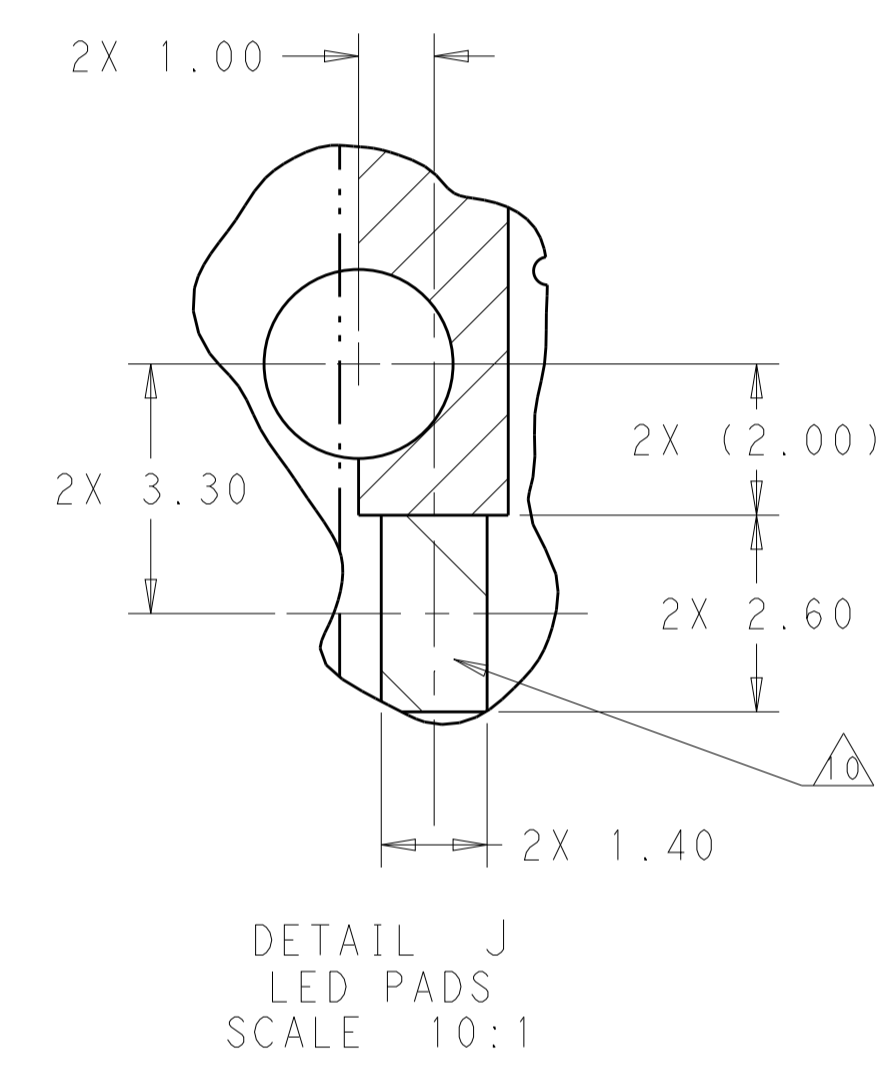
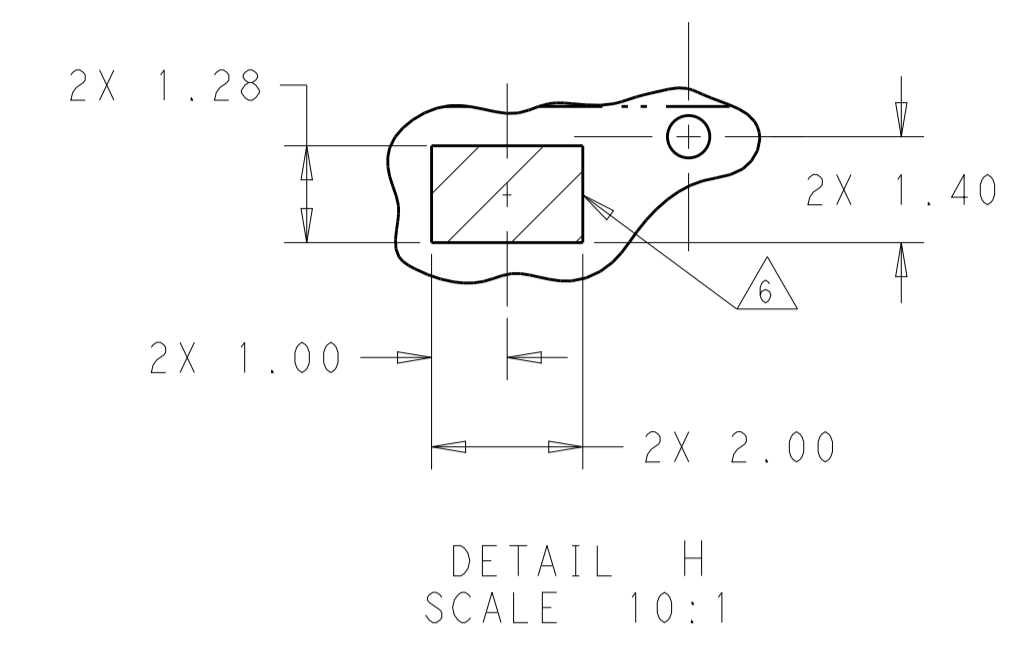
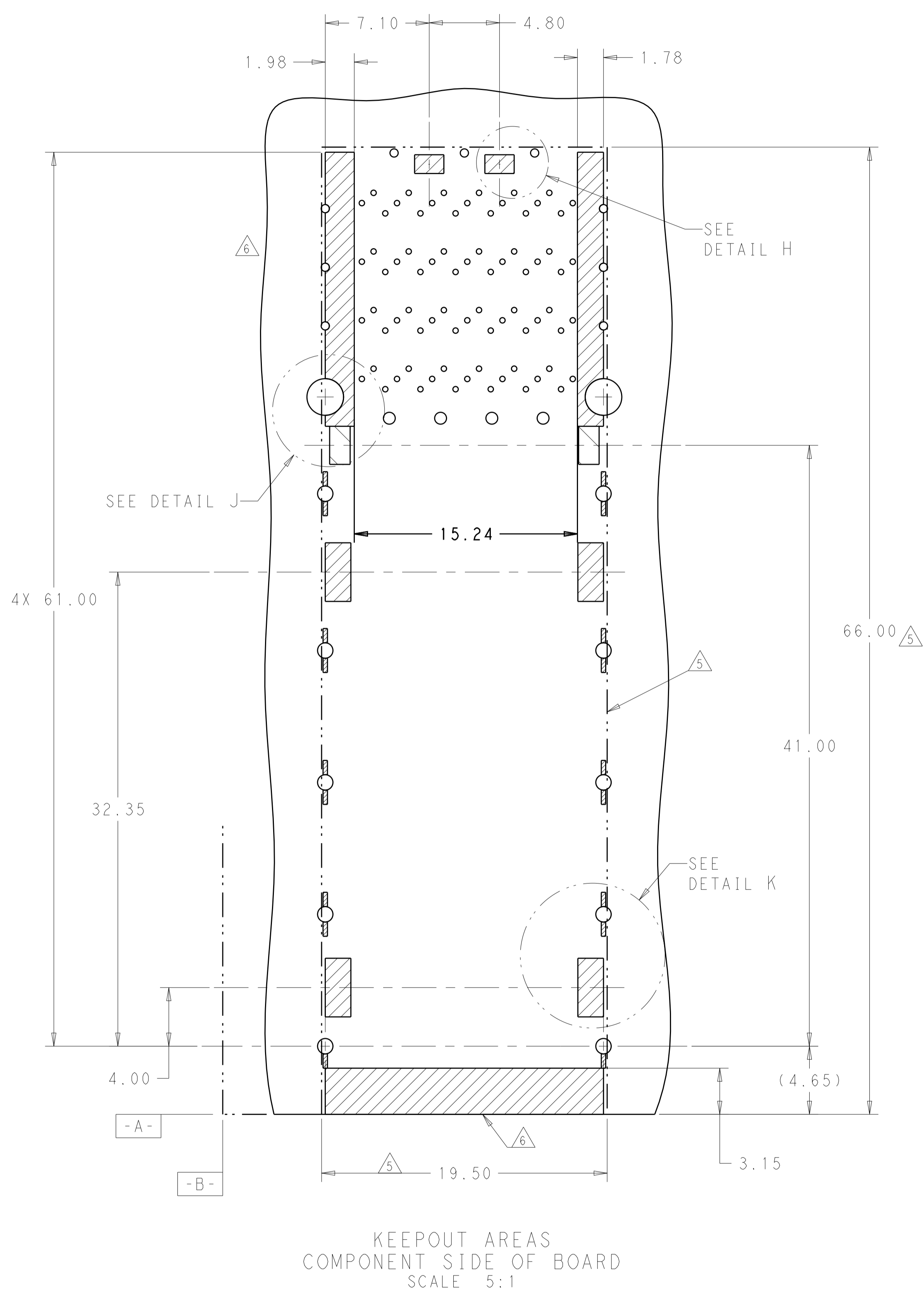

THIS DRAWING IS A CONTROLLED DOCUMENT.		DWN: M. SHIRK 16JAN2013	TE Connectivity
DIMENSIONS: mm		CHK: D. SZCZESNY 16JAN2013	
TOLERANCES UNLESS OTHERWISE SPECIFIED:		APVD: -	NAME: CAGE AND CONNECTOR ASSEMBLY, WITH EMI SPRING FINGERS, THRU BEZEL, 2X1, ZQSFP+ STACKED
0 PLC ±	1 PLC ±0.25	PRODUCT SPEC: 108-60102	SIZE: 114-60015
2 PLC ±0.15	3 PLC ±	APPLICATION SPEC: -	RESTRICTED TO: -
4 PLC ±	ANGLES ±	WEIGHT: -	SCALE: 4:1
MATERIAL: -	FINISH: -	CUSTOMER DRAWING	SHEET 4 OF 4
SEE NOTE 1			REV A