

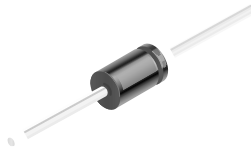

ON Semiconductor®

BZX85C3V3 - BZX85C56 Zener Diodes

Tolerance = 5%



DO-41 Glass Case

COLOR BAND DENOTES CATHODE

Absolute Maximum Ratings

Stresses exceeding the absolute maximum ratings may damage the device. The device may not function or be operable above the recommended operating conditions and stressing the parts to these levels is not recommended. In addition, extended exposure to stresses above the recommended operating conditions may affect device reliability. The absolute maximum ratings are stress ratings only. Values are at $T_A = 25^\circ\text{C}$ unless otherwise noted.

Symbol	Parameter	Value	Units
P_D	Power Dissipation @ $T_A = 25^\circ\text{C}$	1.0	W
	Power Dissipation @ $T_L = 25^\circ\text{C}$ at 4 mm distance from the glass package	1.3	
	Derate above 50°C	6.67	mW/ $^\circ\text{C}$
T_J, T_{STG}	Operating and Storage Temperature Range	-65 to +200	$^\circ\text{C}$

Electrical Characteristics

Values are at $T_A = 25^\circ\text{C}$ unless otherwise noted.

Device	Zener Voltage ⁽¹⁾		Zener Impedance			Leakage Current		
	V_Z (V)		I_Z	$Z_Z @ I_Z$	$Z_{ZK} @ I_{ZK}$		$I_R @ V_R$	
	Min.	Max.	mA	(Ω)	(Ω)	(mA)	$\mu\text{A Max.}$ Volts	
BZX85C3V3	3.1	3.5	80	20	400	1	60	1
BZX85C3V6	3.4	3.8	60	15	500	1	30	1
BZX85C3V9	3.7	4.1	60	15	500	1	5	1
BZX85C4V3	4.0	4.6	50	13	500	1	3	1
BZX85C4V7	4.4	5	45	13	600	1	3	1.5
BZX85C5V1	4.8	5.4	45	10	500	1	1	2
BZX85C5V6	5.2	6	45	7	400	1	1	2
BZX85C6V2	5.8	6.6	35	4	300	1	1	3
BZX85C6V8	6.4	7.2	35	3.5	300	1	1	4
BZX85C7V5	7.0	7.9	35	3	200	0.5	1	4.5
BZX85C8V2	7.7	8.7	25	5	200	0.5	1	5
BZX85C9V1	8.5	9.6	25	5	200	0.5	1	6.5
BZX85C10	9.4	10.6	25	7	200	0.5	0.5	7
BZX85C11	10.4	11.6	20	8	300	0.5	0.5	7.7
BZX85C12	11.4	12.7	20	9	350	0.5	0.5	8.4
BZX85C13	12.4	14.1	20	10	400	0.5	0.5	9.1
BZX85C15	13.8	15.6	15	15	500	0.5	0.5	10.5
BZX85C16	15.3	17.1	15	15	500	0.5	0.5	11
BZX85C18	16.8	19.1	15	20	500	0.5	0.5	12.5
BZX85C20	18.8	21.2	10	24	600	0.5	0.5	14
BZX85C22	20.8	23.3	10	25	600	0.5	0.5	15.5
BZX85C24	22.8	25.6	10	25	600	0.5	0.5	17
BZX85C27	25.1	28.9	8	30	750	0.25	0.5	19
BZX85C30	28	32	8	30	1000	0.25	0.5	21
BZX85C33	31	35	8	35	1000	0.25	0.5	23
BZX85C36	34	38	8	40	1000	0.25	0.5	25
BZX85C39	37	41	6	45	1000	0.25	0.5	27
BZX85C43	40	46	6	50	1000	0.25	0.5	30
BZX85C47	44	50	4	90	1500	0.25	0.5	33
BZX85C51	48	54	4	115	1500	0.25	0.5	36
BZX85C56	52	60	4	120	2000	0.25	0.5	39

V_F Forward Voltage = 1.2 V Max @ $I_F = 200$ mA

Note:

1. Zener Voltage (V_Z): The zener voltage is measured with the device junction in the thermal equilibrium at the lead temperature (T_L) at $30^\circ\text{C} \pm 1^\circ\text{C}$ and 3/8" lead length.

Top Mark Information

Device	Line 1	Line 2	Line 3	Line 4	Line 5
BZX85C3V3	LOGO	85C	3V3		XY
BZX85C3V6	LOGO	85C	3V6		XY
BZX85C3V9	LOGO	85C	3V9		XY
BZX85C4V3	LOGO	85C	4V3		XY
BZX85C4V7	LOGO	85C	4V7		XY
BZX85C5V1	LOGO	85C	5V1		XY
BZX85C5V6	LOGO	85C	5V6		XY
BZX85C6V2	LOGO	85C	6V2		XY
BZX85C6V8	LOGO	85C	6V8		XY
BZX85C7V5	LOGO	85C	7V5		XY
BZX85C8V2	LOGO	85C	8V2		XY
BZX85C9V1	LOGO	85C	9V1		XY
BZX85C10	LOGO	85C	10		XY
BZX85C11	LOGO	85C	11		XY
BZX85C12	LOGO	85C	12		XY
BZX85C13	LOGO	85C	13		XY
BZX85C15	LOGO	85C	15		XY
BZX85C16	LOGO	85C	16		XY
BZX85C18	LOGO	85C	18		XY
BZX85C20	LOGO	85C	20		XY
BZX85C22	LOGO	85C	22		XY
BZX85C24	LOGO	85C	24		XY
BZX85C27	LOGO	85C	27		XY
BZX85C30	LOGO	85C	30		XY
BZX85C33	LOGO	85C	33		XY
BZX85C36	LOGO	85C	36		XY
BZX85C39	LOGO	85C	39		XY
BZX85C43	LOGO	85C	43		XY
BZX85C47	LOGO	85C	47		XY
BZX85C51	LOGO	85C	51		XY
BZX85C56	LOGO	85C	56		XY

Top Mark Information (Continued)

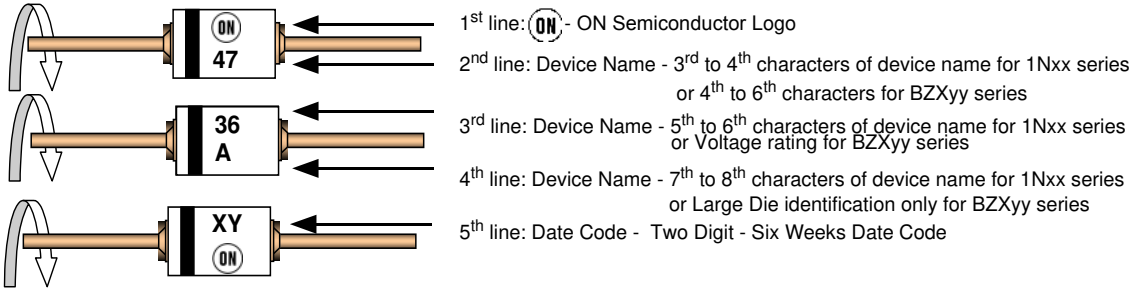

General Requirements:

1.0 Cathode Band

2.0 First Line: - ON Semiconductor Logo

3.0 Second Line: Device name - For 1Nxx series: 3rd to 4th characters of the device name.
For BZxx series: 4th to 6th characters of the device name.

4.0 Third Line: Device name - For 1Nxx series: 5th to 6th characters of the device name.
For BZXyy series: Voltage rating

5.0 Third Line: Device name - For 1Nxx series: 7th to 8th characters of the device name.
(the 8th character is the large die identification)
For BZXyy series: Large Die Identification character

6.0 Fourth Line: Date Code - Two Digit - Six Weeks Date Code
Where: X represents the last digit of the calendar year
Y represents the Six weeks numeric code

7.0 Devices shall be marked as required in the device specification (PID or OSPI Test Spec).

8.0 Maximum no. of marking lines: 5

9.0 Maximum no. of digits per line: 3

10.0 OSPI logo must be 20% taller than the alphanumeric marking and should occupy the 2 characters of the specified line.

11.0 Marking Font: Arial (Except OSPI Logo)

12.0 First character of each marking line must be aligned vertically

13.0 All device markings must be based on ON Semiconductor device specification.

Physical Dimensions

DO-204AL (DO-41)

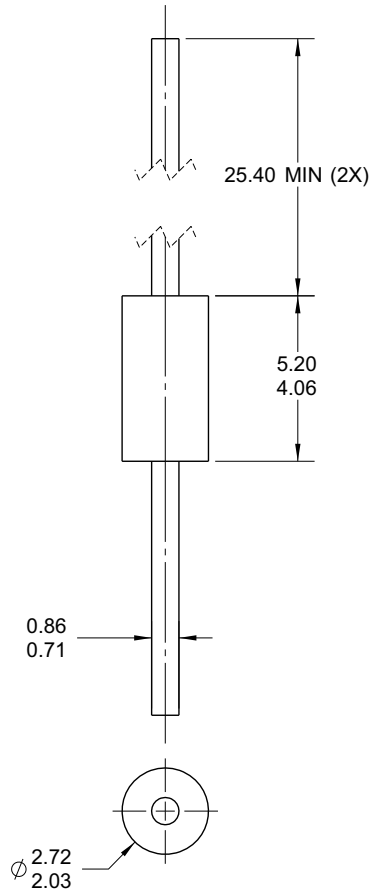

NOTES: UNLESS OTHERWISE SPECIFIED

- A) PACKAGE STANDARD REFERENCE:
JEDEC DO-204 VARIATION AL.
- B) PACKAGE BODY CAN BE PLASTIC OR
HERMETICALLY SEALED GLASS.
- D) ALL DIMENSIONS ARE IN MILLIMETERS.
- E) DRAWING FILE NAME: DO41AREV2

Figure 7. AXIAL LEADED, GLASS, JEDEC DO204, VARIATION AL

Package drawings are provided as a service to customers considering ON Semiconductor components. Drawings may change in any manner without notice. Please note the revision and/or date on the drawing and contact a ON Semiconductor representative to verify or obtain the most recent revision. Package specifications do not expand the terms of ON Semiconductor's worldwide terms and conditions, specifically the warranty therein, which covers ON Semiconductor products.

ON Semiconductor and  are trademarks of Semiconductor Components Industries, LLC dba ON Semiconductor or its subsidiaries in the United States and/or other countries. ON Semiconductor owns the rights to a number of patents, trademarks, copyrights, trade secrets, and other intellectual property. A listing of ON Semiconductor's product/patent coverage may be accessed at www.onsemi.com/site/pdf/Patent-Marking.pdf. ON Semiconductor reserves the right to make changes without further notice to any products herein. ON Semiconductor makes no warranty, representation or guarantee regarding the suitability of its products for any particular purpose, nor does ON Semiconductor assume any liability arising out of the application or use of any product or circuit, and specifically disclaims any and all liability, including without limitation special, consequential or incidental damages. Buyer is responsible for its products and applications using ON Semiconductor products, including compliance with all laws, regulations and safety requirements or standards, regardless of any support or applications information provided by ON Semiconductor. "Typical" parameters which may be provided in ON Semiconductor data sheets and/or specifications can and do vary in different applications and actual performance may vary over time. All operating parameters, including "Typicals" must be validated for each customer application by customer's technical experts. ON Semiconductor does not convey any license under its patent rights nor the rights of others. ON Semiconductor products are not designed, intended, or authorized for use as a critical component in life support systems or any FDA Class 3 medical devices or medical devices with a same or similar classification in a foreign jurisdiction or any devices intended for implantation in the human body. Should Buyer purchase or use ON Semiconductor products for any such unintended or unauthorized application, Buyer shall indemnify and hold ON Semiconductor and its officers, employees, subsidiaries, affiliates, and distributors harmless against all claims, costs, damages, and expenses, and reasonable attorney fees arising out of, directly or indirectly, any claim of personal injury or death associated with such unintended or unauthorized use, even if such claim alleges that ON Semiconductor was negligent regarding the design or manufacture of the part. ON Semiconductor is an Equal Opportunity/Affirmative Action Employer. This literature is subject to all applicable copyright laws and is not for resale in any manner.

PUBLICATION ORDERING INFORMATION

LITERATURE FULFILLMENT:

Literature Distribution Center for ON Semiconductor
19521 E. 32nd Pkwy, Aurora, Colorado 80011 USA
Phone: 303-675-2175 or 800-344-3860 Toll Free USA/Canada
Fax: 303-675-2176 or 800-344-3867 Toll Free USA/Canada
Email: orderlit@onsemi.com

N. American Technical Support: 800-282-9855 Toll Free
USA/Canada
Europe, Middle East and Africa Technical Support:
Phone: 421 33 790 2910
Japan Customer Focus Center
Phone: 81-3-5817-1050

ON Semiconductor Website: www.onsemi.com
Order Literature: <http://www.onsemi.com/orderlit>
For additional information, please contact your local
Sales Representative