

Datasheet

Vehicle Detection Sensor



- 3-axis magnetoresistive-based technology; senses 3-dimensional changes to the Earth's magnetic field caused by the presence of ferrous objects
- Easy sensor installation (see [Installation](#) on p. 5); above- or below-ground mounting options
- Compact, robust one-piece, self-contained sensor package replaces inductive-loop sensing technology; no external controller needed
- Designed to minimize the effects of temperature swings and destabilizing magnetic fields
- Sensor learns ambient background and stores settings in non-volatile memory
- Patented technologies



WARNING:

- **Appropriate use for vehicle detection**— The mechanical opening, braking, and reversing systems of the door will not respond in sufficient time to prevent moving trucks, cars, or material handling vehicles, even those traveling at low speeds, from coming in contact with the door. In addition, the detection zone of the device may fluctuate due to changes in the local magnetic environment.
- Failure to follow these procedures may result in serious injury or death.
- All vehicles should approach doors at speeds that allow the operator to ensure the door is operating properly and in an open position.



WARNING:

- **Do not use this device for personnel protection**
- Using this device for personnel protection could result in serious injury or death.
- This device does not include the self-checking redundant circuitry necessary to allow its use in personnel safety applications. A device failure or malfunction can cause either an energized (on) or de-energized (off) output condition.

Models

Model	Cable ¹	Supply Voltage	Output Type	Range
S18MB	2 m (6.5 ft) 5-conductor cable	10 to 30 V DC	Bipolar NPN/PNP ²	Range varies, depending on application and target being sensed. See Figure 8 and Figure 9 in Typical Target Excess Gain Curves on p. 6.
S18MBQ	5-pin Euro-style QD fitting			

Approved Applications

See [Approved Applications - Extended](#) on p. 2 for more details on factory-approved applications.

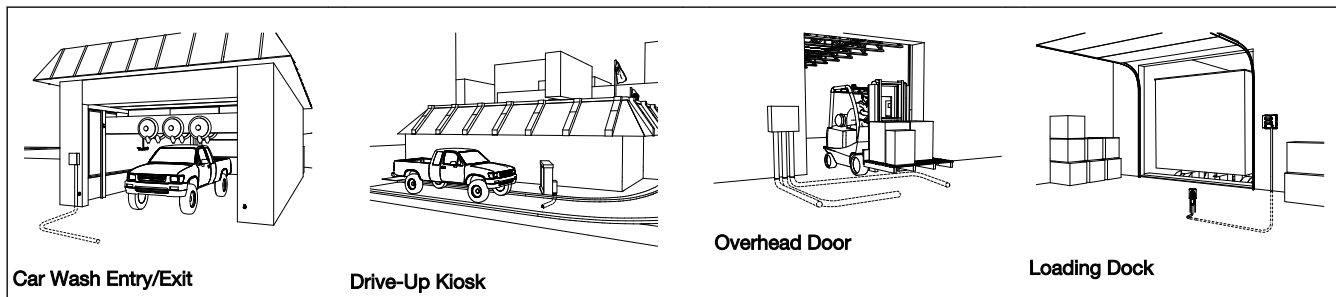

¹ 9 m (29.5 ft) cables are available by adding suffix "W/30" to the model number of any cabled sensor (for example, S18MB W/30). A model with a QD connector requires a mating cable; see [Cordsets](#) on p. 8.
² Consult factory for other output options.



Overview

The M-GAGE S18M sensors implement a passive sensing technology to detect large ferrous objects. The sensor measures the change in the Earth's natural magnetic field (the ambient magnetic field) caused by the introduction of a ferromagnetic object.

This easy-to-use sensor is extremely robust and is unaffected by dirt and moisture, making it ideal for demanding outdoor environments. Simple programming procedures provide flexibility for a variety of applications (see page 5).

Theory of Operation

The sensor uses three mutually perpendicular magnetoresistive transducers. Each transducer detects magnetic field changes along one axis. By incorporating three sensing elements, maximum sensor sensitivity is achieved.

A ferrous object will alter the local (ambient) magnetic field surrounding the object. The magnitude of this magnetic field change is dependent both on the object (size, shape, orientation, and composition) and on the ambient magnetic field (strength and orientation).

During a simple programming procedure, the S18M measures the ambient magnetic field. When a large ferrous object (for example, a truck, automobile, or rail car) alters that magnetic field, the sensor detects the magnetic field changes (anomalies). When the degree of magnetic field change reaches the sensor's threshold, the sensor's discrete outputs switch.

Sensor Field of View and Range

The sensor range depends on three variables:

1. The local magnetic environment (including nearby ferrous material)
2. The magnetic properties of the object to be sensed
3. Sensor settings

The S18M can detect changes in the ambient magnetic field in all directions. As with other sensors, the range will depend on the target. The strong disturbance of a large ferrous object decreases as the distance from the sensor increases, and the magnitude and shape of the disturbance is dependent on the object's shape and content.

The sensor can be programmed to react to magnetic field disturbances of greater or lesser intensity using two adjustments: background condition and sensitivity level.

Once background condition and sensitivity level are set, the sensor is ready to detect the target object. Both settings are stored in non-volatile memory.

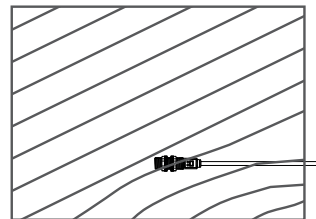

Figure 1. Baseline Magnetic Field

A. Baseline magnetic field, with slight disturbances caused by permanent ferrous-metal objects within or near the sensor.

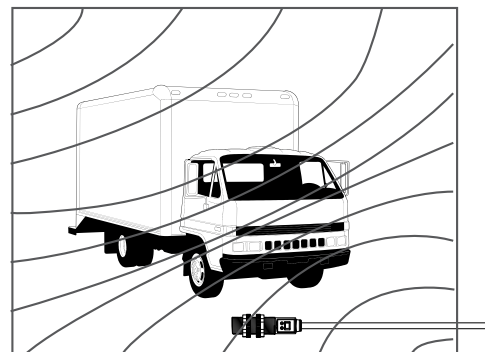

Figure 2. Introduction of Large Steel Object

B. After a large steel target object is introduced, the sensor detects the differential (magnetic strength and orientation) between fields A and B. If the differential is greater than the sensitivity threshold, the sensor's outputs conduct.



Tip: Sensor may be mounted inside a non-ferrous architectural detail for cosmetic or security reasons. It is important that, wherever it is mounted, the sensor is securely attached during configuration and all later use. If the sensor moves after being taught, detection errors may occur and sensor must be re-taught. If a sensor appears to lose its taught settings, it may be a result of having shifted position after setup.

Approved Applications - Extended

The M-GAGE sensor provides a direct replacement for inductive-loop systems, and needs no external frequency controller box. Unique mounting solutions allow an M-GAGE sensor to be replaced easily without disrupting or re-cutting the pavement.

Car Wash Entry/Exit

The Banner M-GAGE vehicle detection sensor will reliably detect vehicles in and around car wash bays. It will reliably detect the presence or absence of a vehicle to provide collision avoidance at the exit of a conveyORIZED tunnel, provide an entry or exit-door trigger, or trigger an undercarriage wash.

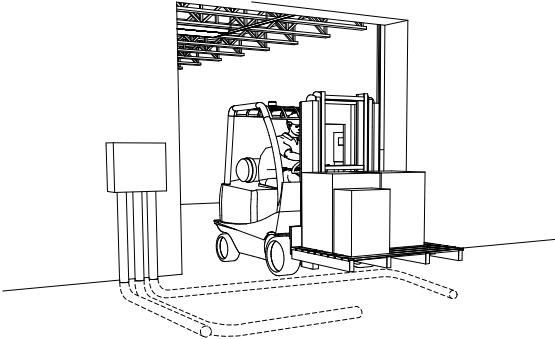
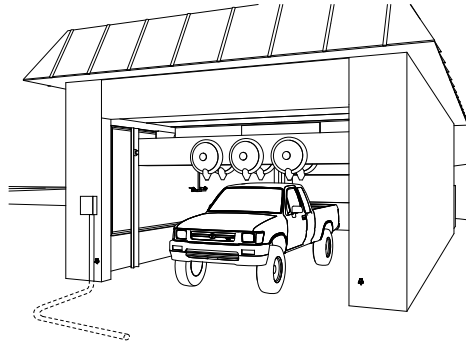

Overhead Door

The Banner M-GAGE sensor can be used to trigger the opening and closing of high-traffic internal overhead doors. Mounted in the floor, it will reliably detect forklifts or trucks as they approach the doors. Banner's applications engineers are available to help determine proper sensor placement for specific door-trigger applications.

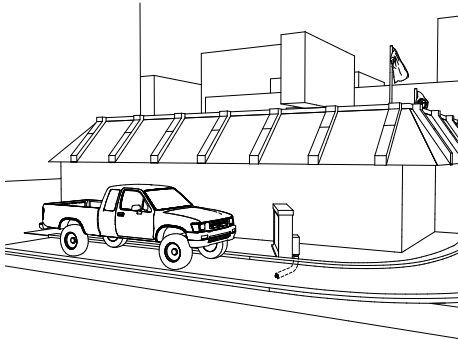

Drive-Up Kiosk

The Banner M-GAGE sensor reliably detects vehicles at drive-through systems or other drive-up kiosks. It will reliably detect a vehicle to trigger personnel that a vehicle is present, and to initiate a timing system.

Loading Dock

The Banner M-GAGE sensor provides multiple advantages for loading docks. It will reliably detect the presence of a vehicle as it backs into a dock, triggering a light on the interior of the building to notify the dock attendant that a vehicle is in position for loading/unloading. The M-GAGE can also be used to trigger dock/ramp leveling systems.

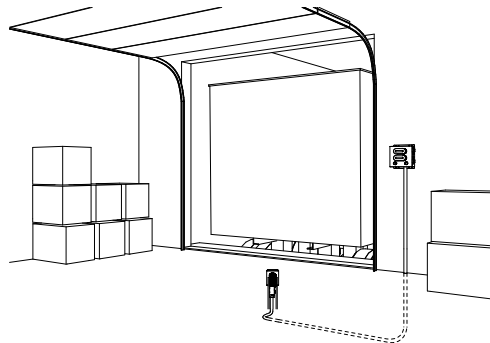

Sensor Configuration

For most applications, configure the M-GAGE sensor remotely, via the DPB2 Portable Programming Box, which provides programming access to an underground or otherwise inaccessible sensor. For optimum performance, the sensor must be secured so that it will not move either during or following configuration.

Configuration using the sensor's built-in push button is useful primarily for demonstration and troubleshooting purposes.

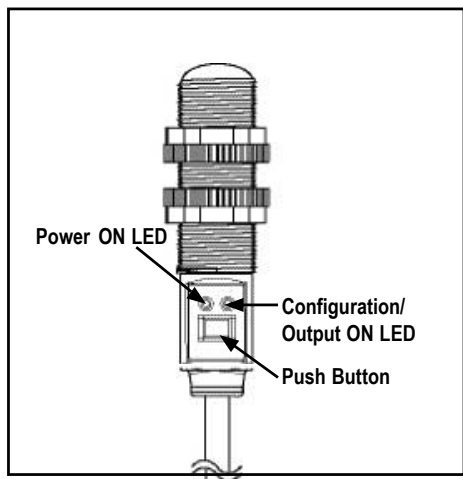

Figure 3. Sensor Features

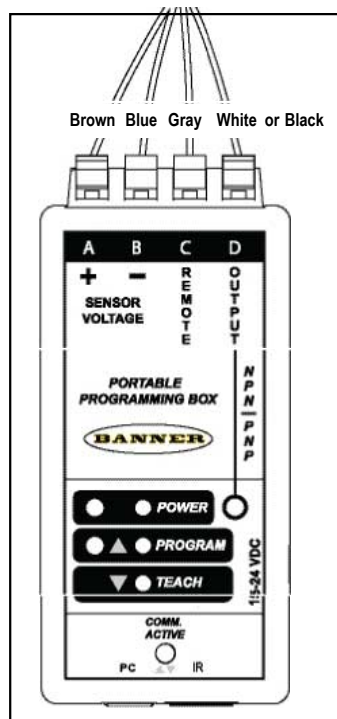

Figure 4. Connecting to the model DPB2 Portable Programming Box

Configuration via the DPB2 Portable Programming Box

Set Background Condition (No Vehicle Present)

Wire the M-GAGE™ sensor as directed. Remove all vehicles and all other metal objects that are temporarily in the sensing area before setting the background condition.

Configuration (0.04 ≤ T ≤ 0.8 seconds)		Result
Set Background	<ul style="list-style-type: none"> Click the DPB2 TEACH push button once. 	<ul style="list-style-type: none"> Sensor learns background. Sensor returns to Run mode.

Set Sensitivity Level

Level 1 = least sensitive, Level 6 = most sensitive.

Configuration (0.04 ≤ T ≤ seconds)		Result
Access Sensitivity Mode	<ul style="list-style-type: none"> Double-click the DPB2 TEACH push button once. 	<ul style="list-style-type: none"> Output LED flashes every 2 seconds; the sensor always begins at sensitivity level 1.
Adjust Sensitivity	<ul style="list-style-type: none"> To increase the sensitivity incrementally, click the push button again; continue until the desired sensitivity level is reached. 	<ul style="list-style-type: none"> Output LED will flash from 1 to 6 times every 2 seconds to indicate sensor's sensitivity level (for example, twice to indicate level 2).
	<ul style="list-style-type: none"> Double-click the push button to save the setting. 	<ul style="list-style-type: none"> Sensor returns to Run mode.
Test Operation	<ul style="list-style-type: none"> Drive a vehicle past/over the sensor to trip the output. Use a small/light vehicle to ensure larger vehicles will be detected later. Adjust the sensitivity as needed. 	
Prepare for Operation	<ul style="list-style-type: none"> Disconnect DPB2 and hard-wire sensor to a permanent power supply or output device (user-supplied). See Wiring on p. 5. 	

Set Push Button Enable/Disable

Configuration		Result
Push Button Enable/Disable	<ul style="list-style-type: none"> Four-click the DPB2 TEACH button to enable or disable the push button. 	<ul style="list-style-type: none"> Sensor toggles between enable/disable settings and returns to Run mode.

Configuration via the Sensor Push Button

Follow the instructions in [Configuration via the DPB2 Portable Programming Box](#) on p. 4, with the following exceptions.

Set Background Condition (No Vehicle Present):

- Press and hold the push button for 2 seconds, until the Output LED turns red.
- Release and then click the push button once.

Set Sensitivity Level:

- Press and hold the push button for 2 seconds, until the Output LED turns red.
- Release and then quickly double-click the push button. Increase the sensitivity by increments as described in [Configuration via the DPB2 Portable Programming Box](#) on p. 4.
- When the sensor is set to the desired sensitivity level, double-click the push button to return the sensor to RUN mode.

Wiring

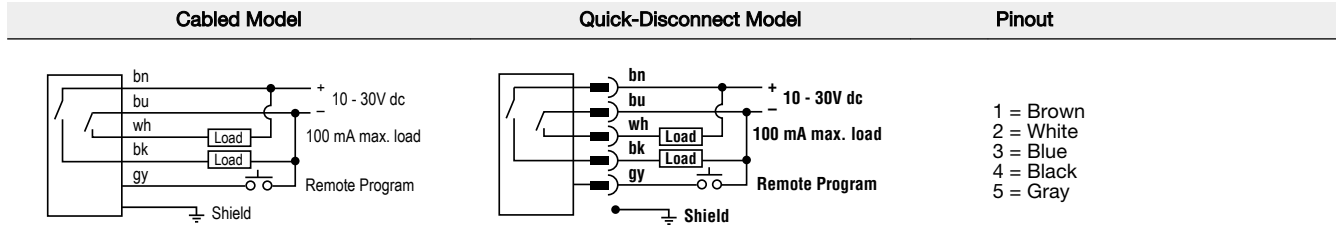

Installation

Below-Grade Installation

Materials

- M-GAGE S18M Sensor
- SMP1 Conduit Plug
- 2" Schedule 80 rigid PVC conduit (1.5" may be used if there is only one 90° bend); total length and number of elbows depend on installation layout
- 2" (or 1.5") rigid PVC end cap (1 per installation)
- 3/4" I.D. flexible, liquid-tight, non-metallic conduit (same length as PVC conduit used for application)
- DPB2 Portable Programming Box

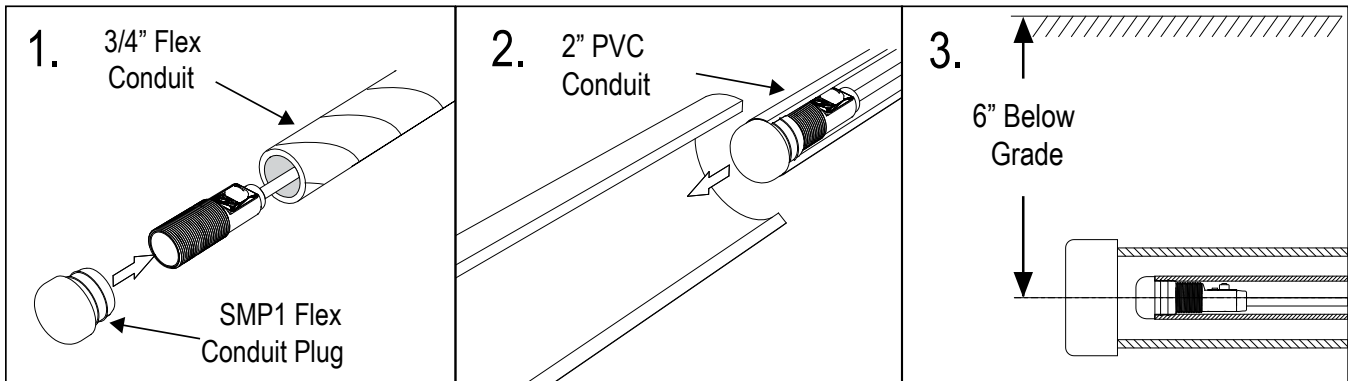

Figure 5. Below-grade installation

Procedure

1. Lay out 2" (or 1.5") PVC in the desired configuration. For the best sensor performance, the sensing location (located at the end of the conduit run) should be 6" below the final surface. Provide an access point where the PVC comes above grade (where the sensor and flex conduit can be fed in or pulled out, as required).
2. Secure the end cap to the PVC, at the sensing location.
3. Measure the overall length of the PVC run, from the sensing location to the control panel.
4. Cut a section of 3/4" flex conduit to span the total distance from the control panel to the sensing location.
5. Thread the sensor into the SMP1 conduit plug. Feed the sensor cable into the flex conduit, until the sensor and plug are snugly seated in the end of the flex conduit.
6. Feed the flex conduit by hand, sensor-end first, into the PVC access point until the sensor reaches the PVC end cap.
7. Secure the remaining flex conduit from the access point to the control cabinet.
8. After the sensor is configured (see following section), wire the sensor into the control device and power supply per the wiring diagram on page 8.

Above-Grade Installation

- M-GAGE S18M Sensor
- SMP2 Conduit Plug
- 3/4" Schedule 40 PVC electrical conduit; total length and number of elbows depend on installation layout
- Electrician's fishtape
- Silicone adhesive
- DPB2 Portable Programming Box

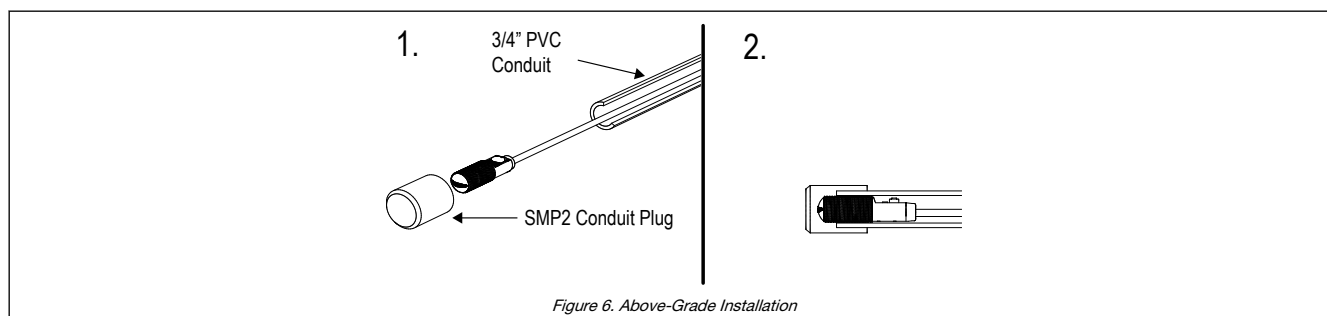

Figure 6. Above-Grade Installation

1. Mount the PVC electrical conduit from the sensing point to the control panel. Plastic conduit should be used for at least the first 6.1 m (20') from the sensing point; metal or flexible conduit may be used the remainder of the distance.
2. Thread the S18M sensor into the threads of the SMP2 conduit plug.
3. Feed the fishtape into the conduit, from the control panel towards the sensing point.
4. Pull the sensor cable back through the conduit, until the sensor almost reaches the end of the plastic conduit. Do NOT pull sensor into conduit.
5. Apply a small amount of silicone adhesive to the outside of the conduit at the sensing point end.
6. Press the conduit plug into the end of the conduit.
7. After the sensor is configured (see following section), wire the sensor into the control device and power supply per the wiring diagram on page 8.

Typical Target Excess Gain Curves

After the sensor has been securely mounted and configured, it is ready to operate. The following two example applications shows typical responses for the M-GAGE™ sensor.

Figure 7 on p. 6 describes mounting the M-GAGE™ 1 meter (3.3 ft) above the ground to sense an automobile. The graph shows the excess gain for a typical car. Excess gain is a measure of the amount of extra signal detected by the sensor over and above the Level needed to detect the target. This example assumes a Level 5 sensitivity threshold.

The table at right compares the change in excess gain if the sensitivity Level changes. If the sensitivity is at Level 6, then the excess gain at a given distance would be 1.3 times larger than for a Level 5 sensitivity. Conversely, if the sensitivity threshold is Level 1, then the excess gain would be one third as big as for Level 5.

Excess Gain vs Sensitivity Level
(Assumes Level 5³)

Level	Excess Gain Multiplier
1	0.33
2	0.4
3	0.5
4	0.66
5	1.0
6	1.3

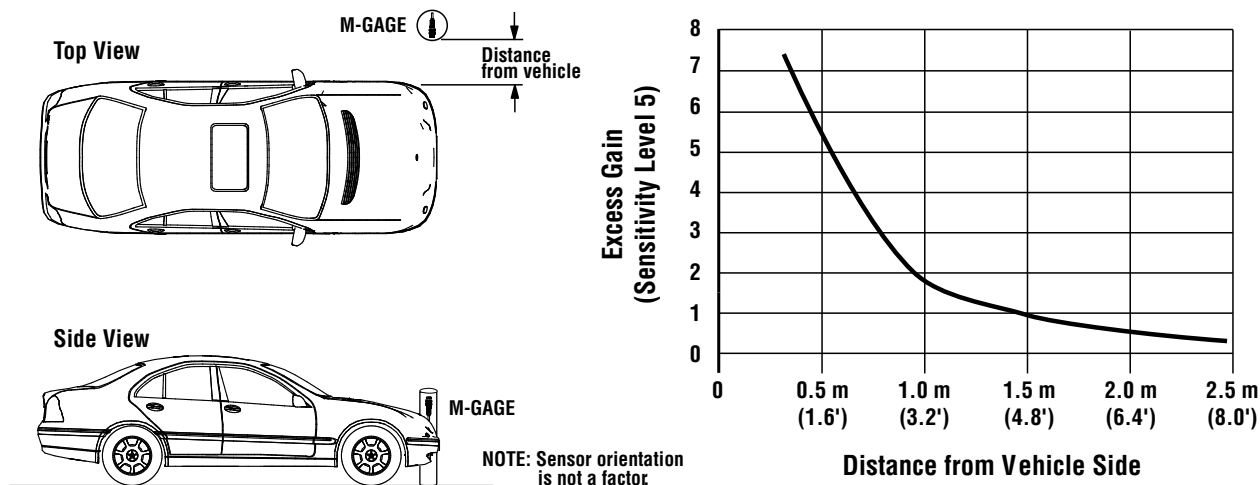

Figure 7. Application example 1: sensor mounted 1 meter (3.3 ft) above ground

Figure 8 on p. 7 illustrates a typical vehicle passing over a sensor mounted underground. Note that excess gain is greatest when the bulk of the vehicle (the rear axle) is positioned directly over the sensor.

³ Factory default setting

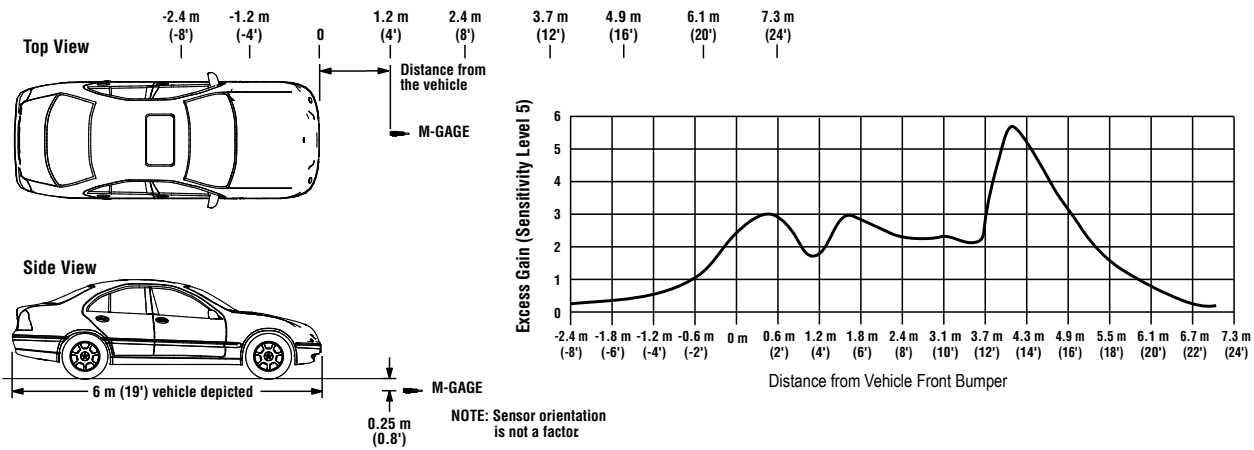

Figure 8. Application example 2: sensor mounted 0.25 meters (0.8 ft) below ground

Specifications

Supply Voltage

10 to 30V dc (10% max. ripple) at 43 mA, exclusive of load
Above +50° C (+122° F), supply voltage is 10 to 24V dc (10% max. ripple)

Sensing Range

See Figure 7 on p. 6 and Figure 8 on p. 7

Sensing Technology

Passive 3-axis magnetoresistive transducer

Supply Protection Circuitry

Protected against reverse polarity and transient voltages

Output Configuration

Two SPST solid-state outputs conduct when object is sensed; one NPN (current sinking) and one PNP (current sourcing)

Output Protection

Protected against short-circuit conditions

Output Ratings

100 mA maximum (each output)
NPN saturation: < 200 mV at 10 mA and < 600 mV at 100 mA
NPN OFF-state leakage current: < 200 microamps
PNP saturation: < 1.2V at 10 mA and < 1.6V at 100 mA
PNP OFF-state leakage current: < 5 microamps

Output Response Time

20 milliseconds

Delay at Power-Up

0.5 seconds

Temperature Effect

< 0.5 milligauss / °C

Adjustments

Configuration of Background Condition and Sensitivity Level may be set using the sensor's push button or remotely via the portable programming box

Indicators

Two indicators

Power Indicator: Green

Configuration/Output Indicator: Red/Yellow

Construction

Threaded Barrel: Thermoplastic polyester

Push Button Housing: ABS/PC

Push Button: Santoprene

Lightpipes: Acrylic

Remote TEACH Input

Impedance 12K ohms

Operating Conditions

-40 °C to +70 °C (-40 °F to +158 °F)

100% maximum relative humidity

Connections

2 m or 9 m shielded 5-conductor (with drain) PVC jacketed attached cable or 5-pin Euro-style quick-disconnect

Environmental Rating

Leak proof design is rated IEC IP69K; NEMA 6P

Vibration and Mechanical Shock

All models meet Mil. Std. 202F requirements method 201A (vibration: 10 to 60Hz max., double amplitude 0.06 in, maximum acceleration 10G). Also meets IEC 947-5-2: 30G 11 ms duration, half sine wave.

Certifications



Dimensions

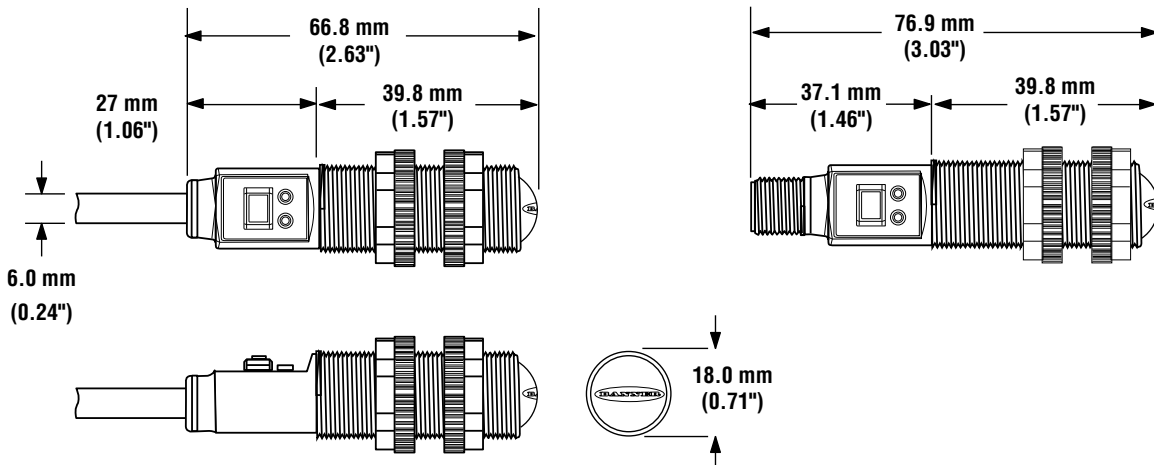

Accessories

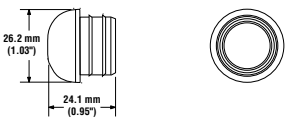
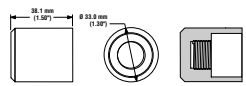
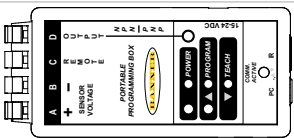
Model	Description	
SMP1	Conduit Plug for 3/4" flexible conduit, used for below-grade installations	
SMP2	Conduit Plug for 3/4" rigid conduit, used for above-grade installations	
DPB2	Handheld Portable Programming Box, used for configuring sensor when push button is not accessible	

Cordsets

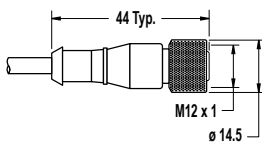
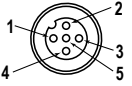
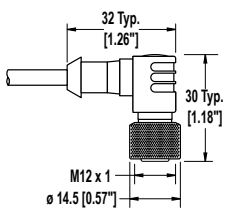
5-Pin Threaded M12/Euro-Style Cordsets with Shield—Single Ended				
Model	Length	Style	Dimensions	Pinout (Female)
MQDEC2-506	2 m (6.56 ft)	Straight		 1 = Brown 2 = White 3 = Blue 4 = Black 5 = Gray
MQDEC2-515	5 m (16.4 ft)			
MQDEC2-530	9 m (29.5 ft)			
MQDEC2-550	15 m (49.2 ft)	Right-Angle		
MQDEC2-506RA	2 m (6.56 ft)			
MQDEC2-515RA	5 m (16.4 ft)			
MQDEC2-530RA	9 m (29.5 ft)			
MQDEC2-550RA	15 m (49.2 ft)			

Banner Engineering Corp Limited Warranty

Banner Engineering Corp. warrants its products to be free from defects in material and workmanship for one year following the date of shipment. Banner Engineering Corp. will repair or replace, free of charge, any product of its manufacture which, at the time it is returned to the factory, is found to have been defective during the warranty period. This warranty does not cover damage or liability for misuse, abuse, or the improper application or installation of the Banner product.

THIS LIMITED WARRANTY IS EXCLUSIVE AND IN LIEU OF ALL OTHER WARRANTIES WHETHER EXPRESS OR IMPLIED (INCLUDING, WITHOUT LIMITATION, ANY WARRANTY OF MERCHANTABILITY OR FITNESS FOR A PARTICULAR PURPOSE), AND WHETHER ARISING UNDER COURSE OF PERFORMANCE, COURSE OF DEALING OR TRADE USAGE.

This Warranty is exclusive and limited to repair or, at the discretion of Banner Engineering Corp., replacement. **IN NO EVENT SHALL BANNER ENGINEERING CORP. BE LIABLE TO BUYER OR ANY OTHER PERSON OR ENTITY FOR ANY EXTRA COSTS, EXPENSES, LOSSES, LOSS OF PROFITS, OR ANY INCIDENTAL, CONSEQUENTIAL OR SPECIAL DAMAGES RESULTING FROM ANY PRODUCT DEFECT OR FROM THE USE OR INABILITY TO USE THE PRODUCT, WHETHER ARISING IN CONTRACT OR WARRANTY, STATUTE, TORT, STRICT LIABILITY, NEGLIGENCE, OR OTHERWISE.**

Banner Engineering Corp. reserves the right to change, modify or improve the design of the product without assuming any obligations or liabilities relating to any product previously manufactured by Banner Engineering Corp. Any misuse, abuse, or improper application or installation of this product or use of the product for personal protection applications when the product is identified as not intended for such purposes will void the product warranty. Any modifications to this product without prior express approval by Banner Engineering Corp will void the product warranties. All specifications published in this document are subject to change; Banner reserves the right to modify product specifications or update documentation at any time. Specifications and product information in English supersede that which is provided in any other language. For the most recent version of any documentation, refer to: www.bannerengineering.com.

For patent information, see www.bannerengineering.com/patents.