

| REVISIONS |     |               |           |     |      |
|-----------|-----|---------------|-----------|-----|------|
| P         | LTR | DESCRIPTION   | DATE      | DWN | APVD |
|           | AG  | ECO-21-006909 | 17SEP2021 | RK  | ZM   |

WHEN ORDERING CONTACT ASSEMBLY ON TAPE, ORDER BY THE TAPE NUMBER PLUS THE PACKAGING CODE AS FOLLOWS:

1. FOR USE WITH AMP TAPETRONIC, PNEUMATIC TOOL-  
A. 1000 PARTS TO A BOX ADD PACKAGING CODE: 1MBOX
2. FOR USE WITH 4/8 INDENT STRIPPER CRIMPER-  
A. 1000 PARTS TO A REEL ADD PACKAGING CODE: 1MREEL  
B. 5000 PARTS TO A REEL ADD PACKAGING CODE: 5MREEL

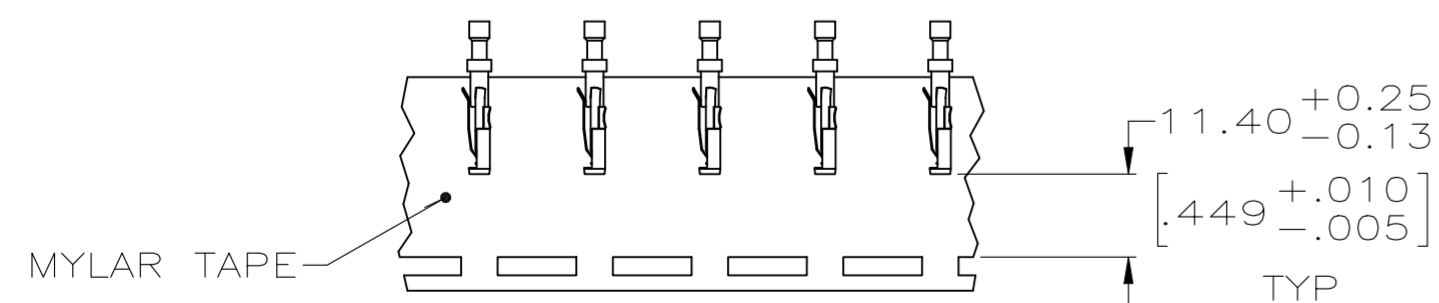
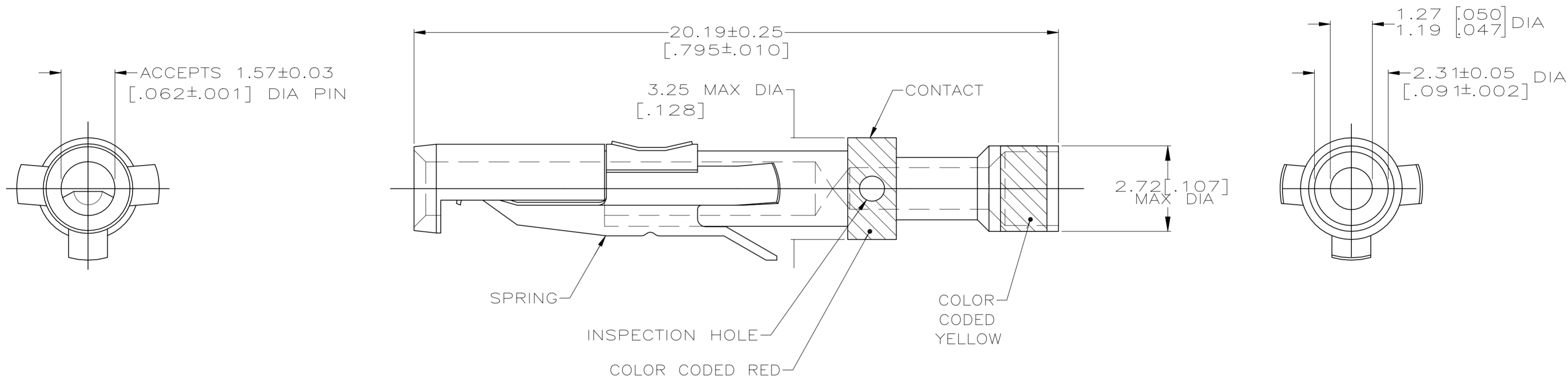

TAPE MTG DETAIL  
SCALE 1:1

|          |                     |                          |
|----------|---------------------|--------------------------|
| OBSOLETE | SMALL PACK KIT      | 1-201328-5<br>1-201328-4 |
| OBSOLETE | TAPE MTG SEE DETAIL | 201328-9                 |
|          | BULK PACKAGING      | 201328-1<br>PART NO      |

|   |  |                             |  |                        |
|---|--|-----------------------------|--|------------------------|
| THIS DRAWING IS A CONTROLLED DOCUMENT.                                      |  | DWN<br>W.G.LENKER<br>5-9-91 | <b>TE</b> TE Connectivity                |                        |
| DIMENSIONS:<br>mm [INCHES]  |  | CHK<br>R.STONE<br>5-14-91   |  |                        |
| TOLERANCES UNLESS OTHERWISE SPECIFIED:                                      |  | APVD<br>R.WALTER<br>5-14-91 | NAME<br>SOCKET CONTACT ASSEMBLY, TYPE II |                        |
| 0 PLC ± -<br>1 PLC ± -<br>2 PLC ± -<br>3 PLC ± -<br>4 PLC ± -<br>ANGLES ± - |  | PRODUCT SPEC<br>-           | SIZE<br>A2                               |                        |
| MATERIAL<br>-   |  | FINISH<br>-                 | CAGE CODE<br>00779                       | DRAWING NO<br>C=201328 |
|   |  | WEIGHT<br>-                 | RESTRICTED TO<br>-                       |                        |
| CUSTOMER DRAWING  |  |                             | SCALE<br>10:1                            | SHEET<br>1 of 1        |
|   |  |                             | REV<br>AG                                |                        |