

8ZJ9E0RS  
( 'ON ONIWAHD)台譽圖

版数 REV.	年月日 DATE	DCN NO.	変更内容 DESCRIPTION	製図 DR.	担当 CHK.	査閲 APPD.	承認 APPD.

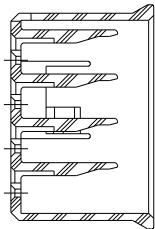

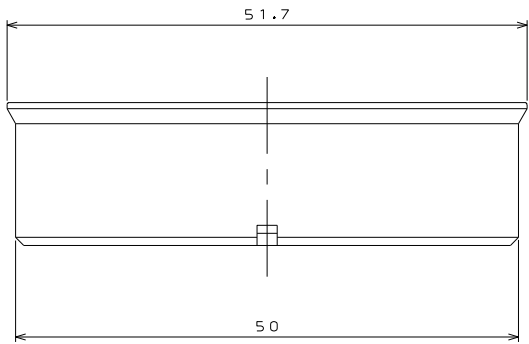
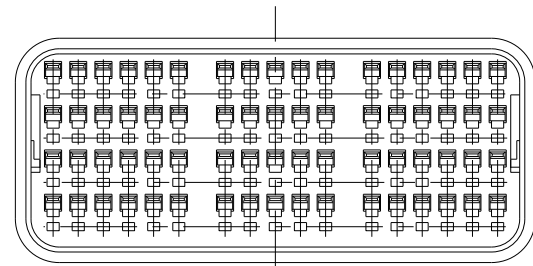
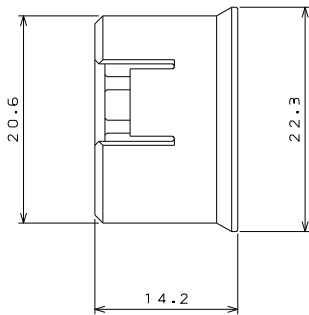
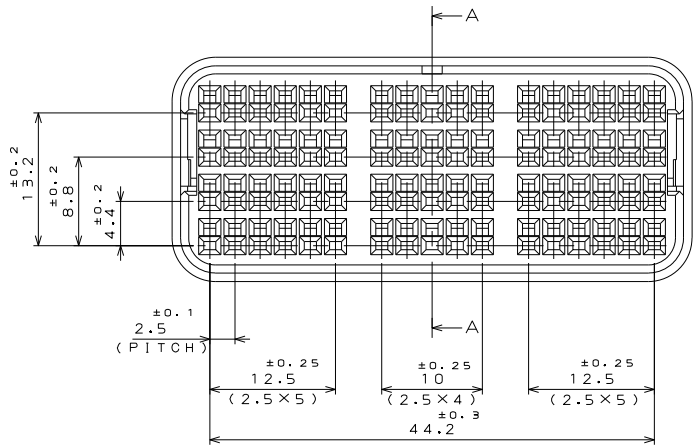

SECT. A-A

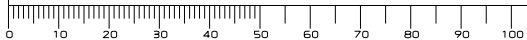

DCF-C-212D(98.02)



— M120-56048		1	30%GF PBT		COLOR: LIGHT BLUE	
符号 NO.	名称 DESCRIPTION	個数 QTY.	材 料 MATERIAL	仕 上 FINISH		備 考 REMARKS
仕様書 (SPECIFICATION) JACS-1686 JAHL-1686		第1版 (ORIGINAL DATE) 29.Oct.2001		尺度 (SCALE) 2:1	シリーズ (SERIES) MX23	日本航空電子工業株式会社 JAPAN AVIATION ELECTRONICS INDUSTRY, LTD.  図面番号 (DRAWING NO.) SJ036378
一般公差 (GENERAL TOLERANCE)		製図 DR.	名称 (TITLE) M120-56048		FRONT CAP (MX23-68S)	
寸法 (DIMENSION)		担当 CHK.	M.WATANABE			
角度 (ANGLES)		査閲 APPD.				
. ±0.8		承認 APPD.	Y. ICHIYAMA			
.X ±0.4					重量 (WEIGHT)	
.XX ±0.1						
.XXX ±						

本図面は日本航空電子工業(株)の所有する情報を含むもので当社の許可なく複製を禁止する。  
THIS DRAWING CONTAINS INFORMATION THAT IS PROPRIETARY TO JAE AND CAN NOT BE REPRODUCED WITHOUT WRITTEN CONSENT OF JAE.

CDS-01-110-10454

SIZE A3

版数 (REV.) 1