

CS-023E 3.2x2.5mm Crystal Resonator



2111 Comprehensive Drive
Aurora, Illinois 60505
Phone: 630-851-4722
Fax: 630-851-5040
www.conwin.com

Description:

The Connor-Winfield CS-023E is a 3.2x2.5mm surface mount AT-cut 3rd Overtone crystal. The CS-023E is used as the reference crystal in many frequency synthesizer and PLL applications.

Features:

- Frequency: 114.285 MHz
- Frequency Calibration: ± 20 ppm
- Frequency Stability: ± 20 ppm
- Temperature Range: -40 to 85°C
- Surface Mount Package
- Tape and Reel Packaging
- RoHS Compliant / Lead Free

Electrical Specifications

Parameter	Minimum	Nominal	Maximum	Units	Notes
Output Frequency (Fo)	-	114.285	-	MHz	
Frequency Calibration (@25°C)	-20	-	20	ppm	
Frequency Stability vs. Change in Temperature	-20	-	20	ppm	
Operating Temperature Range:	-40	-	85	°C	
Operation Mode	3rd Overtone				
Cut	AT Cut				
Aging	-3	-	3	ppm/Year	
Shunt Capacitance: (Co)	-	-	2.5	pF	
Load Capacitance: (CL)	-	18	-	pF	
Equivalent Series Resistance @ 25 °C	-	-	50	Ohms	
Drive Level	-	100	200	uW	
Insulation Resistance	-	500	-	Mohm	@ 100 Vdc
Storage Temperature:	-55	-	125	°C	

Package Characteristics

Package	Hermetically sealed ceramic 3.2x2.5mm SMD Package.
Leakage	0.01ppm atm, cc/sec. maximum

Ordering Information

CS-023E-114.285M

Package Outline

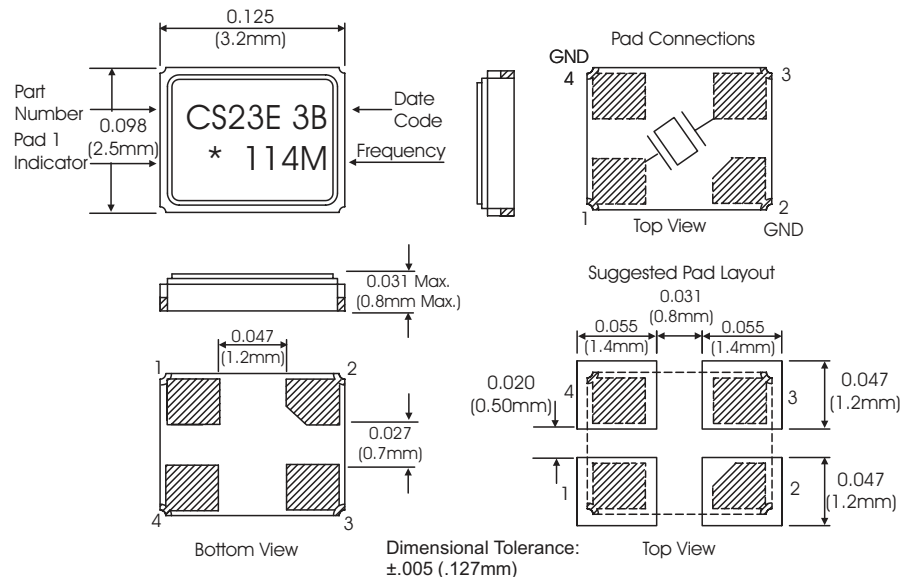



Tape and Reel Information

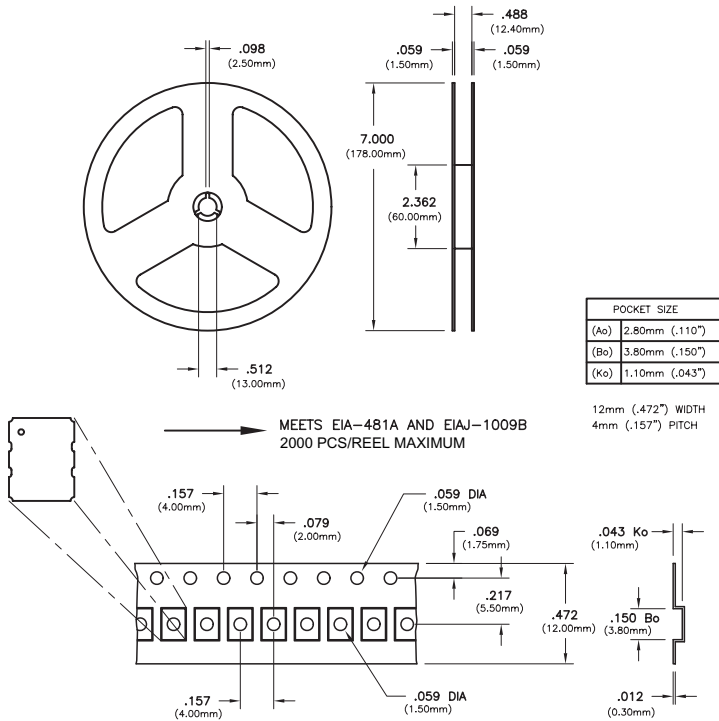

Date Code Information

2 Character Date Code

Year Code	Month Code
3 = 2013	A = January
4 = 2014	B = February
5 = 2015	C = March
6 = 2016	D = April
7 = 2017	E = May
8 = 2018	F = June
9 = 2019	G = July
0 = 2020	H = August
1 = 2021	J = September
2 = 2022	K = October
	M = November
	N = December

Date Code Example: 9G

9 = 2019, G = July

Marking Information

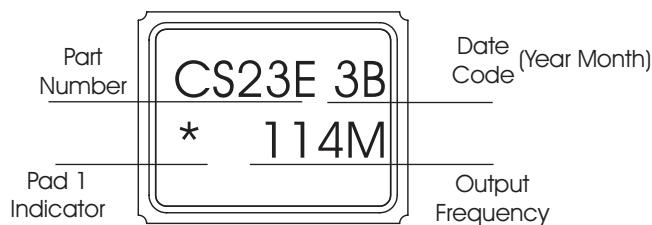

Solder Profile

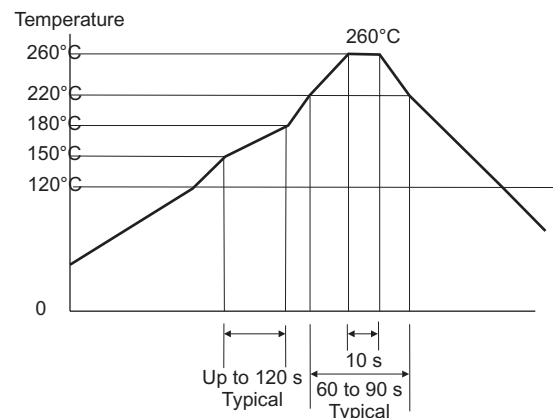

Meets IPC/JEDEC J-STD-020C

DLD Testing Information

100% of the crystals are measured at the following drive levels in the order listed:

10nw
25nw
50nw
100nw
500nw
1uw
5uw
10uw
50uw
100uw

The reference value is the ESR and FL at 50uw

The Frequency and resistance measurements are then compared to the reference value and P/F limits are as follows:
10/25/50 nw levels 2.0 ppm max, 10% ESR max Remaining drive levels 1.0 ppm max, 10% ESR max.

All devices are tested once and no retesting allowed.

CS-023E is tested -40 to 85 °C every 2°C with no discontinuities > 1 ppm and the change in R - effective < 10%

Revision History

Revision	Date	Changes
00	02/11/13	New Issue
01	04/02/14	Revision to Shunt Capacitance
02	10/05/16	Update to Description, Drive Level and Date Code Information
03	07/24/19	Updated tape and reel information and date code table.

Bulletin	Xt361
Page	3 of 3
Revision	03
Date	24 July 2019