

Drivers for DC Brush Motors

Dual H-Bridge Driver High-Speed Switching Type

BD63572MUV

General Description

The BD63572MUV provides a dual H-Bridge motor driver which features wide range of motor power supply voltage from 2.0 V to 9.0 V and low power consumption to switch low ON-Resistance DMOS transistors at high speed. This small surface mounting package is most suitable for mobile system, home appliance and various applications.

Features

- Low ON-Resistance Power DMOS Output
- Charge Pump-less with PDMOS High-Side Driver
- Drive Mode Switch Function
- Under Voltage Locked Out Protection and Thermal Shutdown Function

Applications

- Mobile System
- Home Appliance
- Amusement System, etc.

Key Specifications

- Power Supply Voltage Range: 2.5 V to 3.6 V
- Motor Power Supply Voltage Range: 2.0 V to 9.0 V
- Circuit Current (Open Mode): 740 μ A(Typ)
- Stand-by Current: 1 μ A (Max)
- Control Input Voltage Range: 0 V to V_{CC}
- Logic Input Frequency: 1000 kHz(Max)
- Minimum Logic Input Pulse Width: 100 ns(Min)
- Turn On Time: 45 ns(Typ)
- Turn Off Time: 45 ns(Typ)
- H-Bridge Output Current (DC): -1.0 A to +1.0 A
- H-Bridge Output Current (Peak): -2.5 A to +2.5 A
- Output ON-Resistance (Total): 0.40 Ω (Typ)
- Operating Temperature Range: -30 $^{\circ}$ C to +85 $^{\circ}$ C

Package

VQFN20PV3535

W(Typ) x D(Typ) x H(Max)

3.50 mm x 3.50 mm x 1.00 mm

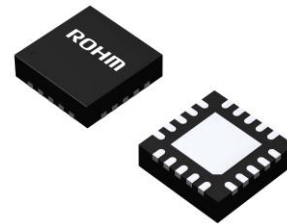

VQFN20PV3535

Typical Application Circuit

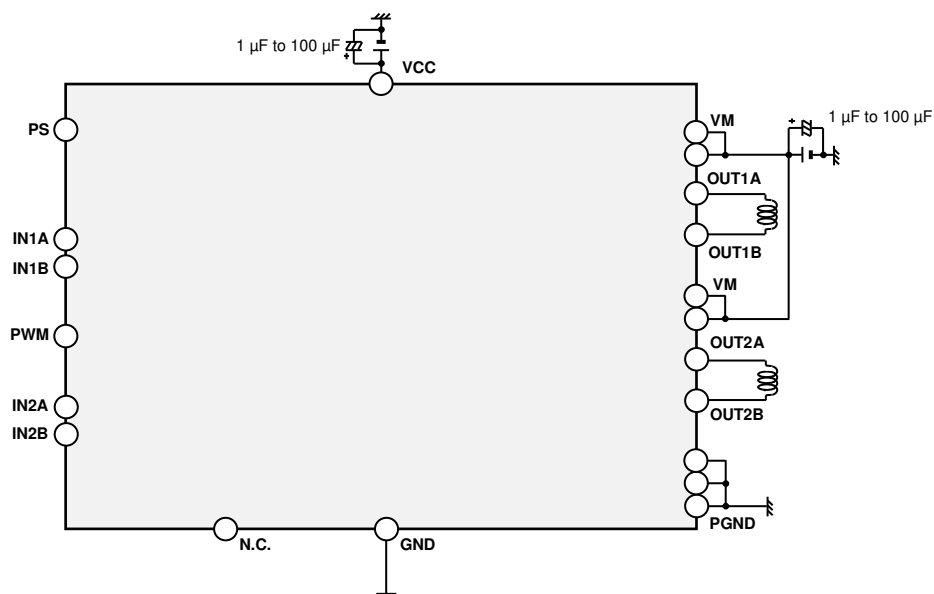

○Product structure : Silicon integrated circuit ○This product has no designed protection against radioactive rays

Pin Configuration

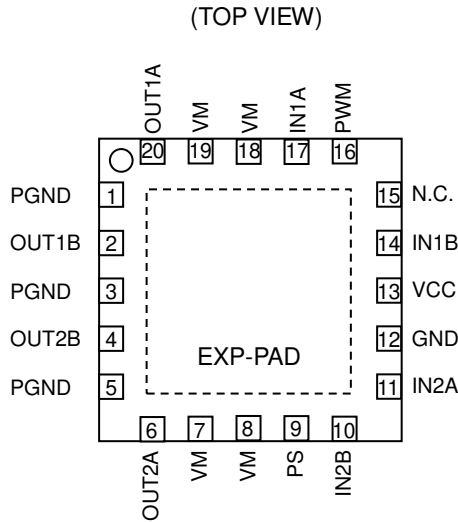

Pin Description

Pin No.	Pin Name	Function	Pin No.	Pin Name	Function
1	PGND	Motor ground	12	GND	Small signal ground
2	OUT1B	H-Bridge output 1B	13	VCC	Power supply
3	PGND	Motor ground	14	IN1B	Control logic input 1B
4	OUT2B	H-Bridge output 2B	15	N.C.	Always keep open.
5	PGND	Motor ground	16	PWM	Drive mode logic input
6	OUT2A	H-Bridge output 2A	17	IN1A	Control logic input 1A
7	VM	Motor power supply	18	VM	Motor power supply
8	VM	Motor power supply	19	VM	Motor power supply
9	PS	Power-Saving function	20	OUT1A	H-Bridge output 1A
10	IN2B	Control logic input 2B	-	EXP-PAD	The EXP-PAD of the center connect to GND Pin.
11	IN2A	Control logic input 2A			

Block Diagram

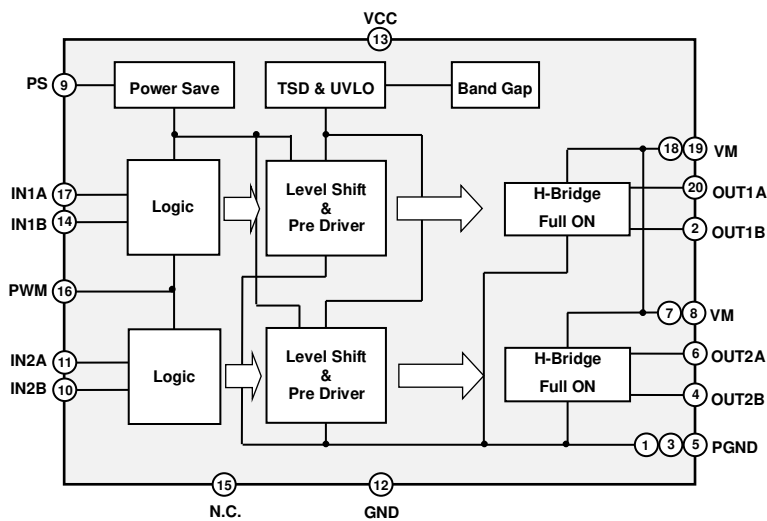

Description of Functions

1. Power-Saving Function
A Power-Saving Function is included, which allows the system to save power when not driving the motor. The voltage level on the PS Pin should be set high so as to keep the Active Mode. (See the Electrical Characteristics)
2. Motor Control Input
 - (a) IN1A, IN1B, IN2A and IN2B Pins
Logic level controls the output logic of H-Bridge.
(See the Electrical Characteristics, and I/O Truth Table)
 - (b) PWM Pin
Logic level sets the IN/IN or EN/IN drive mode.
(See the Electrical Characteristics and I/O Truth Table)
3. VM Pin
Each H-Bridge can be controlled independently. Take into consideration that each VM Pin (Pin No.7, 8, 18 and 19 pins) are short-circuited internally. (See the Block Diagram) Each VM Pins must be shorted on printed circuit board.
4. PGND Pin
Each PGND Pins must be shorted on printed circuit board.

Absolute Maximum Ratings (Ta=25 °C)

Parameter	Symbol	Rating	Unit
Power Supply Voltage	V _{CC}	-0.3 to +4.5	V
Motor Power Supply Voltage	V _M	-0.3 to +10.0	V
Control Input Voltage	V _{IN}	-0.3 to V _{CC} +0.3	V
H-Bridge Output Current (DC)	I _{OUT}	-1.0 to +1.0 ^(Note 1)	A
H-Bridge Output Current (PEAK)	I _{OUT(PEAK)}	-2.5 to +2.5 ^(Note 2)	A
Maximum Junction Temperature	T _{jmax}	150	°C
Storage Temperature Range	T _{stg}	-55 to +150	°C

Caution 1: Operating the IC over the absolute maximum ratings may damage the IC. The damage can either be a short circuit between pins or an open circuit between pins and the internal circuitry. Therefore, it is important to consider circuit protection measures, such as adding a fuse, in case the IC is operated over the absolute maximum ratings.

Caution 2: Should by any chance the maximum junction temperature rating be exceeded the rise in temperature of the chip may result in deterioration of the properties of the chip. In case of exceeding this absolute maximum rating, design PCB boards with thermal resistance taken into consideration by increasing board size and copper area so as not to exceed the maximum junction temperature rating.

(Note 1) ASO and T_j=150 °C should not be exceeded.

(Note 2) PEAK=100 ms (Duty≤10 %). ASO and T_j=150 °C should not be exceeded.

Thermal Resistance ^(Note 3)

Parameter	Symbol	Thermal Resistance (Typ)		Unit
		1s ^(Note 5)	2s2p ^(Note 6)	
VQFN20PV3535				
Junction to Ambient	θ _{JA}	181.9	50.5	°C/W
Junction to Top Characterization Parameter ^(Note 4)	Ψ _{JT}	19	7	°C/W

(Note 3) Based on JE51-2A (Still-Air)

(Note 4) The thermal characterization parameter to report the difference between junction temperature and the temperature at the top center of the outside surface of the component package.

(Note 5) Using a PCB board based on JE51-3.

Layer Number of Measurement Board	Material	Board Size
Single	FR-4	114.3 mm x 76.2 mm x 1.57 mmt

Top	
Copper Pattern	Thickness
Footprints and Traces	70 μm

(Note 6) Using a PCB board based to JE51-5, 7.

Layer Number of Measurement Board	Material	Board Size	Thermal Via ^(Note 7)		
			Pitch	Diameter	
4 Layers	FR-4	114.3 mm x 76.2 mm x 1.6 mmt	1.20 mm	Φ0.30 mm	
Top		2 Internal Layers		Bottom	
Copper Pattern	Thickness	Copper Pattern	Thickness	Copper Pattern	Thickness
Footprints and Traces	70 μm	74.2 mm x 74.2 mm	35 μm	74.2 mm x 74.2 mm	70 μm

(Note 7) This thermal via connects with the copper pattern of all layers.

Recommended Operation Conditions

Parameter	Symbol	Min	Typ	Max	Unit
Power Supply Voltage	V _{CC}	2.5	-	3.6	V
Motor Power Supply Voltage	V _M	2.0	-	9.0	V
Control Input Voltage	V _{IN}	0	-	V _{CC}	V
Logic Input Frequency	f _{IN}	0	-	1000	kHz
Minimum Logic Input Pulse Width	t _{IN}	100	-	-	ns
Operation Temperature	T _{opr}	-30	-	+85	°C

Electrical Characteristics (Unless otherwise specified, $V_{CC}=3.0\text{ V}$, $V_M=5.0\text{ V}$, $T_a=25\text{ }^\circ\text{C}$)

Parameter	Symbol	Min	Typ	Max	Unit	Conditions
All Circuits						
Stand-by Current	I_{CCST}	-	0	1	μA	$V_{PS}=0\text{ V}$
Circuit Current 1	I_{CC1}	200	740	1150	μA	$V_{PS}=3\text{ V}$, Open Mode ^(Note 8)
Circuit Current 2	I_{CC2}	200	750	1150	μA	$V_{PS}=3\text{ V}$, CW & CCW Mode ^(Note 8)
Circuit Current 3	I_{CC3}	300	770	1200	μA	$V_{PS}=3\text{ V}$, Short Brake Mode ^(Note 8)
PS Input (PS)						
High-Level Input Voltage	V_{PSH}	1.85	-	V_{CC}	V	
Low-Level Input Voltage	V_{PSL}	0	-	0.9	V	
High-Level Input Current	I_{PSH}	15	30	60	μA	$V_{PS}=3\text{ V}$
Low-Level Input Current	I_{PSL}	-1	0	+1	μA	$V_{PS}=0\text{ V}$
Control Input (IN=IN1A, IN1B, IN2A, IN2B, PWM)						
High-Level Input Voltage	V_{INH}	1.85	-	V_{CC}	V	
Low-Level Input Voltage	V_{INL}	0	-	0.9	V	
High-Level Input Current	I_{INH}	15	30	60	μA	$V_{IN}=3\text{ V}$
Low-Level Input Current	I_{INL}	-1	0	+1	μA	$V_{IN}=0\text{ V}$
Under Voltage Locked Out (UVLO)						
UVLO Voltage	V_{UVLO}	2.0	-	2.4	V	
FULL ON Type H-Bridge Driver						
Output ON-Resistance	R_{ON}	-	0.40	0.60	Ω	$I_{OUT}=\pm 500\text{ mA}$, High & Low-side total Resistance
Turn On Time	t_{ON}	-	45	200	ns	20 Ω Loading
Turn Off Time	t_{OFF}	-	45	200	ns	20 Ω Loading

(Note 8) Refer to Table 1.

Typical Performance Curves (Reference Data)

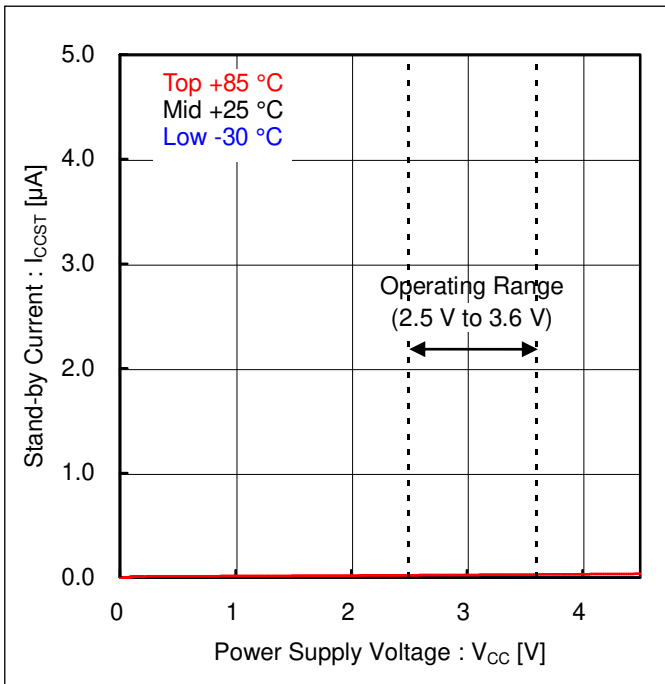

Figure 1. Stand-by Current vs Power Supply Voltage (Stand-by Mode)

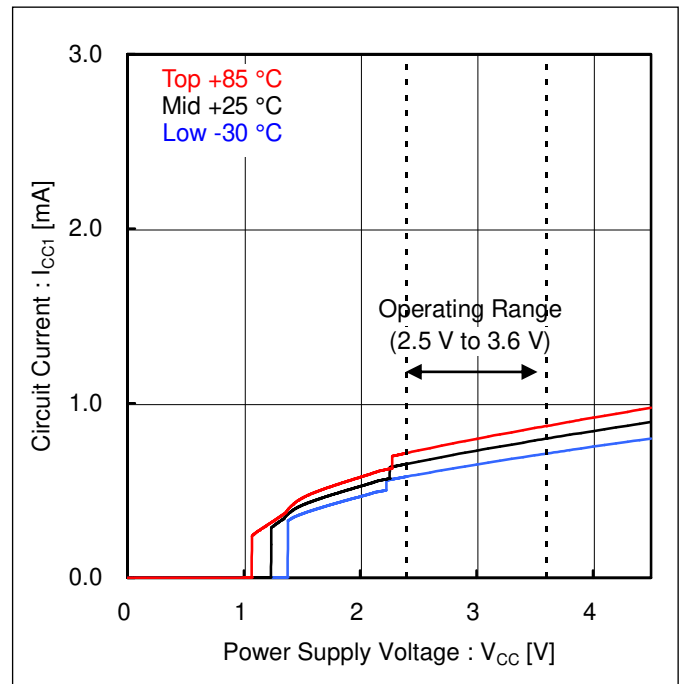

Figure 2. Circuit Current vs Power Supply Voltage (Open Mode)

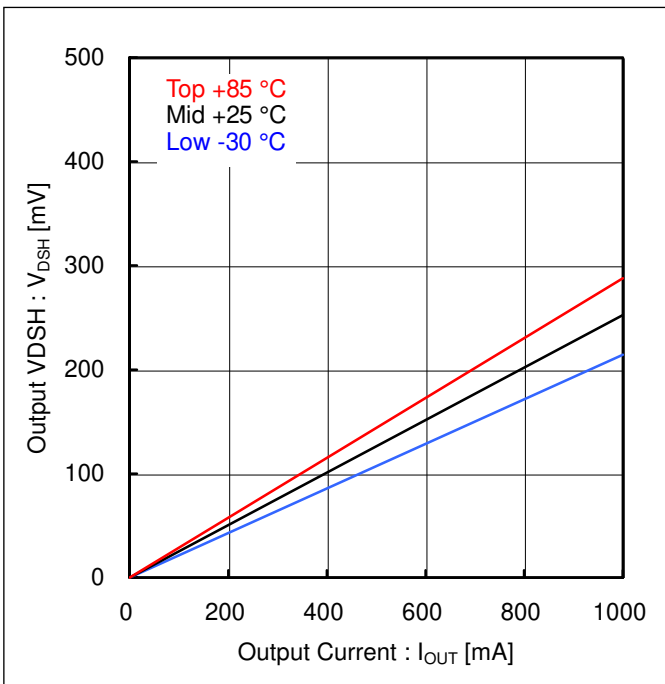

Figure 3. Output VDSH vs Output Current (Output ON-Resistance on high-side, $V_M=5\text{ V}$, $V_{CC}=3\text{ V}$)

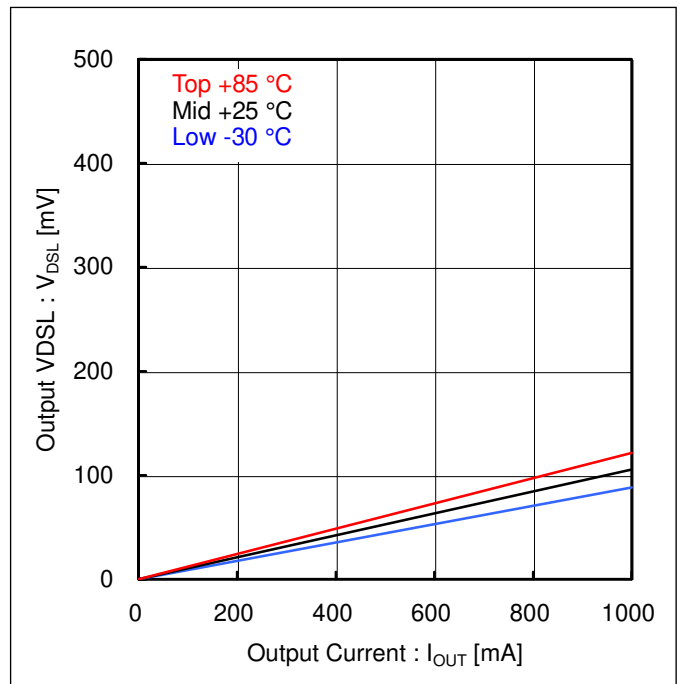

Figure 4. Output VDSL vs Output Current (Output ON-Resistance on low-side, $V_M=5\text{ V}$, $V_{CC}=3\text{ V}$)

Typical Performance Curves (Reference Data) - continued

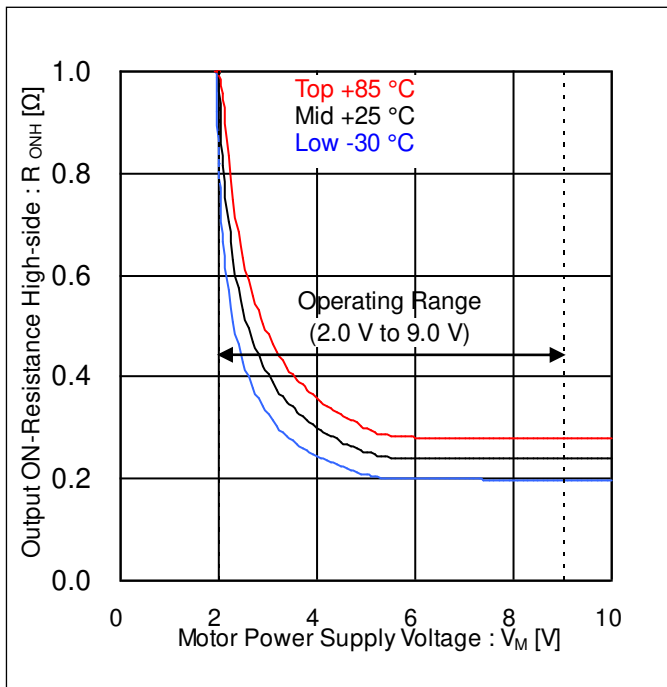

Figure 5. Output ON-Resistance High-side vs Motor Power Supply Voltage
 (Output ON-Resistance on High-side V_M Dependency, $V_{CC}=3$ V)

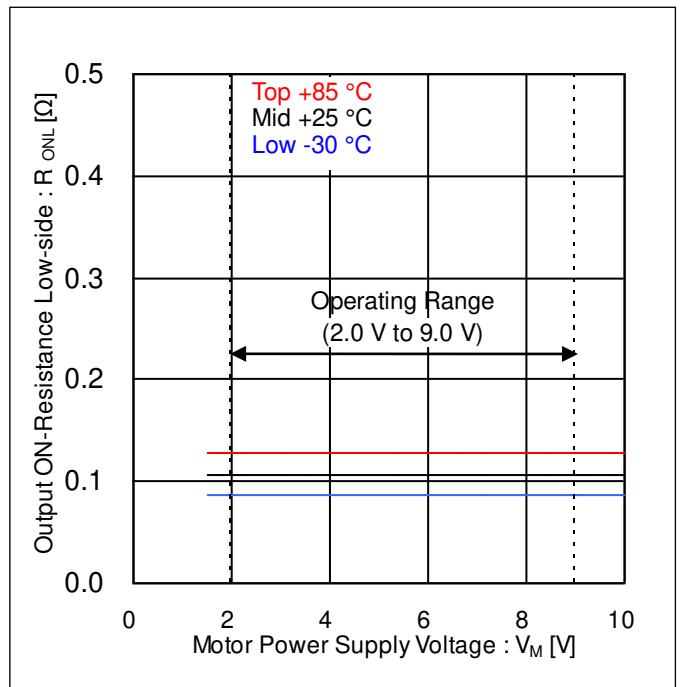

Figure 6. Output ON-Resistance Low-side vs Motor Power Supply Voltage
 (Output ON-Resistance on Low-side V_M Dependency, $V_{CC}=3$ V)

Timing Chart

Table 1. I/O Truth Table

Input Mode	INPUT				OUTPUT			
	PS ^(Note 9)	PWM	IN1A / IN2A	IN1B / IN2B	OUT1A / OUT2A	OUT1B / OUT2B	Output Mode ^(Note 10)	
EN/IN	H	H	L	X	L	L	Short Brake	
			H	L	H	L	CW	
			H	H	L	H	CCW	
IN/IN		L	L	L	L	Z	Z	Open
				H	L	H	L	CW
				L	H	L	H	CCW
				H	H	L	L	Short Brake
-	L	X	X	X	Z	Z	Open	

L: Low, H: High, X: Don't care, Z: Hi impedance

(Note 9) PS=High: Active Mode, PS=Low: Stand-by Mode

(Note 10) CW: Current flows from OUTxA to OUTxB, CCW: Current flows from OUTxB to OUTxA (x=1,2)

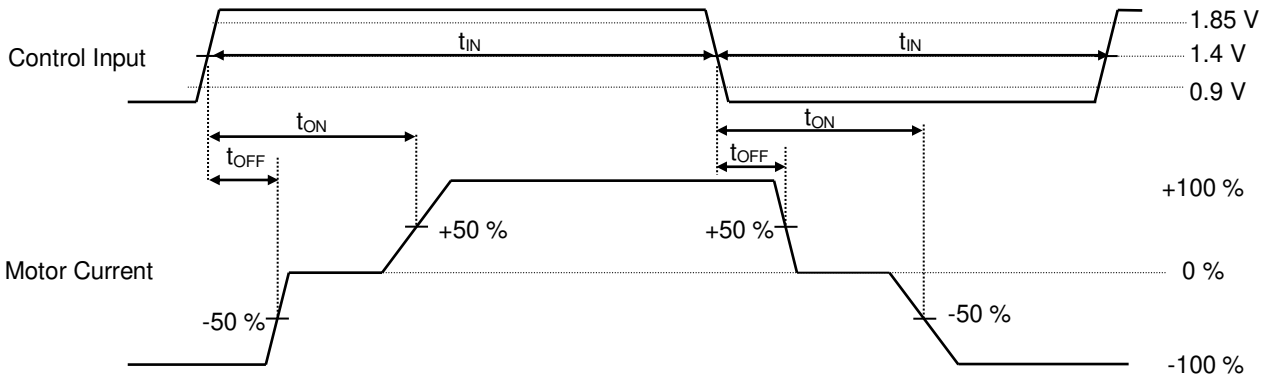

Figure 7. Input-Output AC Characteristic 1

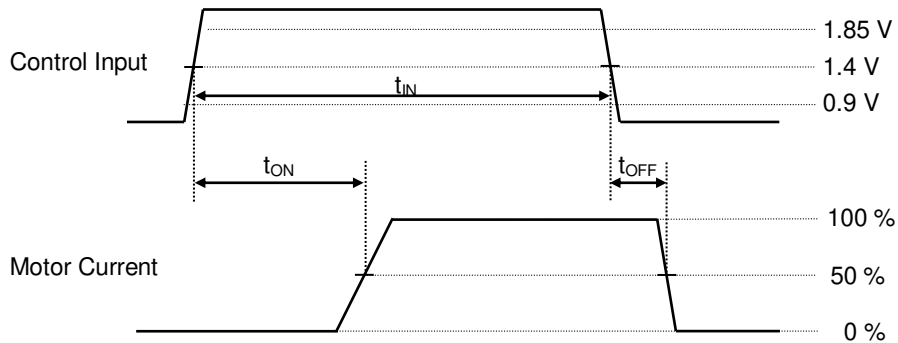
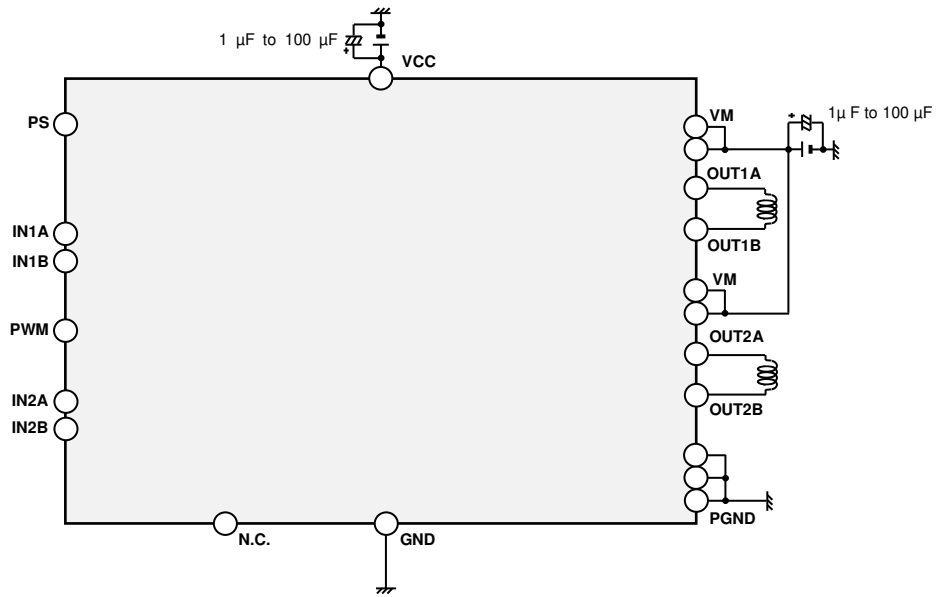

Figure 8. Input-Output AC Characteristic 2

Application Example



Selection of Components Externally Connected

When using the circuit with changes to the external circuit constants, make sure to leave an adequate margin for external components including static and transitional characteristics as well as dispersion of the IC.

I/O Equivalence Circuits

PS	IN1A, IN1B, IN2A, IN2B, PWM	VM, PGND, OUTxA, OUTxB (x=1,2)

Operational Notes

1. Reverse Connection of Power Supply

Connecting the power supply in reverse polarity can damage the IC. Take precautions against reverse polarity when connecting the power supply, such as mounting an external diode between the power supply and the IC's power supply pins.

2. Power Supply Lines

Design the PCB layout pattern to provide low impedance supply lines. Separate the ground and supply lines of the digital and analog blocks to prevent noise in the ground and supply lines of the digital block from affecting the analog block. Furthermore, connect a capacitor to ground at all power supply pins. Consider the effect of temperature and aging on the capacitance value when using electrolytic capacitors.

3. Ground Voltage

Ensure that no pins are at a voltage below that of the ground pin at any time, even during transient condition.

4. Ground Wiring Pattern

When using both small-signal(GND) and large-current ground(PGND) traces, the two ground traces should be routed separately but connected to a single ground at the reference point of the application board to avoid fluctuations in the small-signal ground caused by large currents. Also ensure that the ground traces of external components do not cause variations on the ground voltage. The ground lines must be as short and thick as possible to reduce line impedance.

5. Recommended Operating Conditions

The function and operation of the IC are guaranteed within the range specified by the recommended operating conditions. The characteristic values are guaranteed only under the conditions of each item specified by the electrical characteristics.

6. Inrush Current

When power is first supplied to the IC, it is possible that the internal logic may be unstable and inrush current may flow instantaneously due to the internal powering sequence and delays, especially if the IC has more than one power supply. Therefore, give special consideration to power coupling capacitance, power wiring, width of ground wiring, and routing of connections.

7. Operation Under Strong Electromagnetic Field

Operating the IC in the presence of a strong electromagnetic field may cause the IC to malfunction.

8. Testing on Application Boards

When testing the IC on an application board, connecting a capacitor directly to a low-impedance output pin may subject the IC to stress. Always discharge capacitors completely after each process or step. The IC's power supply should always be turned off completely before connecting or removing it from the test setup during the inspection process. To prevent damage from static discharge, ground the IC during assembly and use similar precautions during transport and storage.

9. Inter-pin Short and Mounting Errors

Ensure that the direction and position are correct when mounting the IC on the PCB. Incorrect mounting may result in damaging the IC. Avoid nearby pins being shorted to each other especially to ground, power supply and output pin. Inter-pin shorts could be due to many reasons such as metal particles, water droplets (in very humid environment) and unintentional solder bridge deposited in between pins during assembly to name a few.

10. Unused Input Pins

Input pins of an IC are often connected to the gate of a MOS transistor. The gate has extremely high impedance and extremely low capacitance. If left unconnected, the electric field from the outside can easily charge it. The small charge acquired in this way is enough to produce a significant effect on the conduction through the transistor and cause unexpected operation of the IC. So, unless otherwise specified, unused input pins should be connected to the power supply or ground line.

Operational Notes – continued

11. Regarding the Input Pin of the IC

This monolithic IC contains P+ isolation and P substrate layers between adjacent elements in order to keep them isolated. P-N junctions are formed at the intersection of the P layers with the N layers of other elements, creating a parasitic diode or transistor. For example (refer to figure below):

When $GND > Pin A$ and $GND > Pin B$, the P-N junction operates as a parasitic diode.

When $GND > Pin B$, the P-N junction operates as a parasitic transistor.

Parasitic diodes inevitably occur in the structure of the IC. The operation of parasitic diodes can result in mutual interference among circuits, operational faults, or physical damage. Therefore, conditions that cause these diodes to operate, such as applying a voltage lower than the GND voltage to an input pin (and thus to the P substrate) should be avoided.

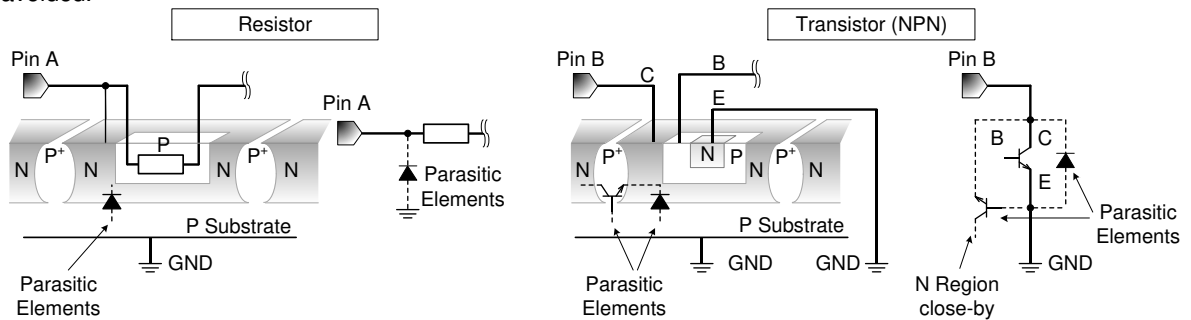

Figure 9. Example of monolithic IC structure

12. Ceramic Capacitor

When using a ceramic capacitor, determine a capacitance value considering the change of capacitance with temperature and the decrease in nominal capacitance due to DC bias and others.

13. Area of Safe Operation (ASO)

Operate the IC such that the output voltage, output current, and the maximum junction temperature rating are all within the Area of Safe Operation (ASO).

14. Thermal Shutdown Circuit(TSD)

This IC has a built-in thermal shutdown circuit that prevents heat damage to the IC. Normal operation should always be within the IC's maximum junction temperature rating. If however the rating is exceeded for a continued period, the junction temperature (T_j) will rise which will activate the TSD circuit that will turn OFF power output pins. When the T_j falls below the TSD threshold, the circuits are automatically restored to normal operation.

Note that the TSD circuit operates in a situation that exceeds the absolute maximum ratings and therefore, under no circumstances, should the TSD circuit be used in a set design or for any purpose other than protecting the IC from heat damage.

Ordering Information

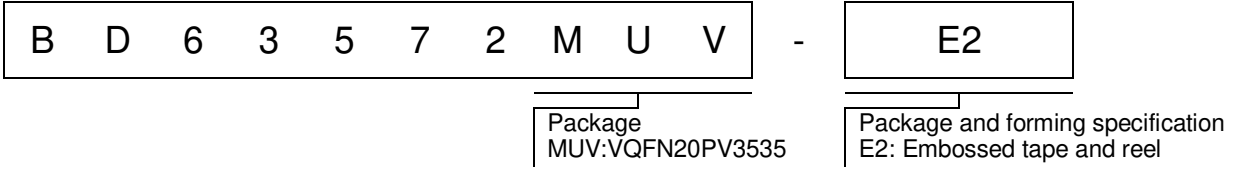

Marking Diagram

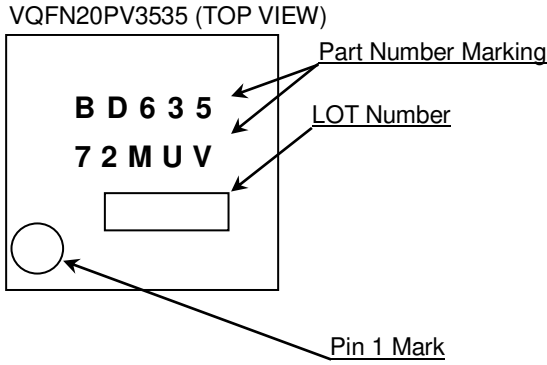

Revision History

Date	Revision	Changes
07.Dec.2017	001	New Release
25.Jan.2019	002	Change Physical Dimension and Packing Information

Notice

Precaution on using ROHM Products

- Our Products are designed and manufactured for application in ordinary electronic equipment (such as AV equipment, OA equipment, telecommunication equipment, home electronic appliances, amusement equipment, etc.). If you intend to use our Products in devices requiring extremely high reliability (such as medical equipment ^(Note 1), transport equipment, traffic equipment, aircraft/spacecraft, nuclear power controllers, fuel controllers, car equipment including car accessories, safety devices, etc.) and whose malfunction or failure may cause loss of human life, bodily injury or serious damage to property ("Specific Applications"), please consult with the ROHM sales representative in advance. Unless otherwise agreed in writing by ROHM in advance, ROHM shall not be in any way responsible or liable for any damages, expenses or losses incurred by you or third parties arising from the use of any ROHM's Products for Specific Applications.

(Note1) Medical Equipment Classification of the Specific Applications

JAPAN	USA	EU	CHINA
CLASS III	CLASS III	CLASS II b	CLASS III
CLASS IV		CLASS III	

- ROHM designs and manufactures its Products subject to strict quality control system. However, semiconductor products can fail or malfunction at a certain rate. Please be sure to implement, at your own responsibilities, adequate safety measures including but not limited to fail-safe design against the physical injury, damage to any property, which a failure or malfunction of our Products may cause. The following are examples of safety measures:
 - Installation of protection circuits or other protective devices to improve system safety
 - Installation of redundant circuits to reduce the impact of single or multiple circuit failure
- Our Products are designed and manufactured for use under standard conditions and not under any special or extraordinary environments or conditions, as exemplified below. Accordingly, ROHM shall not be in any way responsible or liable for any damages, expenses or losses arising from the use of any ROHM's Products under any special or extraordinary environments or conditions. If you intend to use our Products under any special or extraordinary environments or conditions (as exemplified below), your independent verification and confirmation of product performance, reliability, etc. prior to use, must be necessary:
 - Use of our Products in any types of liquid, including water, oils, chemicals, and organic solvents
 - Use of our Products outdoors or in places where the Products are exposed to direct sunlight or dust
 - Use of our Products in places where the Products are exposed to sea wind or corrosive gases, including Cl₂, H₂S, NH₃, SO₂, and NO₂
 - Use of our Products in places where the Products are exposed to static electricity or electromagnetic waves
 - Use of our Products in proximity to heat-producing components, plastic cords, or other flammable items
 - Sealing or coating our Products with resin or other coating materials
 - Use of our Products without cleaning residue of flux (Exclude cases where no-clean type fluxes is used. However, recommend sufficiently about the residue.) ; or Washing our Products by using water or water-soluble cleaning agents for cleaning residue after soldering
 - Use of the Products in places subject to dew condensation
- The Products are not subject to radiation-proof design.
- Please verify and confirm characteristics of the final or mounted products in using the Products.
- In particular, if a transient load (a large amount of load applied in a short period of time, such as pulse, is applied, confirmation of performance characteristics after on-board mounting is strongly recommended. Avoid applying power exceeding normal rated power; exceeding the power rating under steady-state loading condition may negatively affect product performance and reliability.
- De-rate Power Dissipation depending on ambient temperature. When used in sealed area, confirm that it is the use in the range that does not exceed the maximum junction temperature.
- Confirm that operation temperature is within the specified range described in the product specification.
- ROHM shall not be in any way responsible or liable for failure induced under deviant condition from what is defined in this document.

Precaution for Mounting / Circuit board design

- When a highly active halogenous (chlorine, bromine, etc.) flux is used, the residue of flux may negatively affect product performance and reliability.
- In principle, the reflow soldering method must be used on a surface-mount products, the flow soldering method must be used on a through hole mount products. If the flow soldering method is preferred on a surface-mount products, please consult with the ROHM representative in advance.

For details, please refer to ROHM Mounting specification

Precautions Regarding Application Examples and External Circuits

1. If change is made to the constant of an external circuit, please allow a sufficient margin considering variations of the characteristics of the Products and external components, including transient characteristics, as well as static characteristics.
2. You agree that application notes, reference designs, and associated data and information contained in this document are presented only as guidance for Products use. Therefore, in case you use such information, you are solely responsible for it and you must exercise your own independent verification and judgment in the use of such information contained in this document. ROHM shall not be in any way responsible or liable for any damages, expenses or losses incurred by you or third parties arising from the use of such information.

Precaution for Electrostatic

This Product is electrostatic sensitive product, which may be damaged due to electrostatic discharge. Please take proper caution in your manufacturing process and storage so that voltage exceeding the Products maximum rating will not be applied to Products. Please take special care under dry condition (e.g. Grounding of human body / equipment / solder iron, isolation from charged objects, setting of ionizer, friction prevention and temperature / humidity control).

Precaution for Storage / Transportation

1. Product performance and soldered connections may deteriorate if the Products are stored in the places where:
 - [a] the Products are exposed to sea winds or corrosive gases, including Cl₂, H₂S, NH₃, SO₂, and NO₂
 - [b] the temperature or humidity exceeds those recommended by ROHM
 - [c] the Products are exposed to direct sunshine or condensation
 - [d] the Products are exposed to high Electrostatic
2. Even under ROHM recommended storage condition, solderability of products out of recommended storage time period may be degraded. It is strongly recommended to confirm solderability before using Products of which storage time is exceeding the recommended storage time period.
3. Store / transport cartons in the correct direction, which is indicated on a carton with a symbol. Otherwise bent leads may occur due to excessive stress applied when dropping of a carton.
4. Use Products within the specified time after opening a humidity barrier bag. Baking is required before using Products of which storage time is exceeding the recommended storage time period.

Precaution for Product Label

A two-dimensional barcode printed on ROHM Products label is for ROHM's internal use only.

Precaution for Disposition

When disposing Products please dispose them properly using an authorized industry waste company.

Precaution for Foreign Exchange and Foreign Trade act

Since concerned goods might be fallen under listed items of export control prescribed by Foreign exchange and Foreign trade act, please consult with ROHM in case of export.

Precaution Regarding Intellectual Property Rights

1. All information and data including but not limited to application example contained in this document is for reference only. ROHM does not warrant that foregoing information or data will not infringe any intellectual property rights or any other rights of any third party regarding such information or data.
2. ROHM shall not have any obligations where the claims, actions or demands arising from the combination of the Products with other articles such as components, circuits, systems or external equipment (including software).
3. No license, expressly or implied, is granted hereby under any intellectual property rights or other rights of ROHM or any third parties with respect to the Products or the information contained in this document. Provided, however, that ROHM will not assert its intellectual property rights or other rights against you or your customers to the extent necessary to manufacture or sell products containing the Products, subject to the terms and conditions herein.

Other Precaution

1. This document may not be reprinted or reproduced, in whole or in part, without prior written consent of ROHM.
2. The Products may not be disassembled, converted, modified, reproduced or otherwise changed without prior written consent of ROHM.
3. In no event shall you use in any way whatsoever the Products and the related technical information contained in the Products or this document for any military purposes, including but not limited to, the development of mass-destruction weapons.
4. The proper names of companies or products described in this document are trademarks or registered trademarks of ROHM, its affiliated companies or third parties.

General Precaution

1. Before you use our Products, you are requested to carefully read this document and fully understand its contents. ROHM shall not be in any way responsible or liable for failure, malfunction or accident arising from the use of any ROHM's Products against warning, caution or note contained in this document.
2. All information contained in this document is current as of the issuing date and subject to change without any prior notice. Before purchasing or using ROHM's Products, please confirm the latest information with a ROHM sales representative.
3. The information contained in this document is provided on an "as is" basis and ROHM does not warrant that all information contained in this document is accurate and/or error-free. ROHM shall not be in any way responsible or liable for any damages, expenses or losses incurred by you or third parties resulting from inaccuracy or errors of or concerning such information.