

## GENERAL DESCRIPTION

The SP2525A device is an integrated high-side power switch ideal for self-powered and bus-powered Universal Serial Bus (USB) applications.

The high-side switches are MOSFETs with  $70\text{m}\Omega$   $R_{DS(ON)}$ , which meets USB voltage drop requirements for maximum transmission wire length. Multi-purpose open-drain fault flag output indicates over-current limiting, thermal shutdown, or under voltage lockout. Output current is typically limited to 0.85A below the 5A safety requirement, and the thermal shutdown function shuts the switch off to prevent damage under overcurrent conditions. Guaranteed minimum output rise time limits inrush current during hot plug-in, minimizing EMI and preventing the voltage at the upstream port from dropping excessively.

The SP2525A is offered in a RoHS compliant "green"/halogen free 8-pin NSOIC package.

## APPLICATIONS

- Self Powered USB 2.0 and 3.0 Hubs
- USB Compliant V<sub>Bus</sub> Power Distribution
- Audio-Video Equipments
- Generic Power Switching

## FEATURES

- +3.0V to +5.5V Input Voltage Range
- 500mA Continuous Load Current per Channel
- 2.6V Undervoltage Lockout
- 1.25A Short Circuit Current Limit
- 100m $\Omega$  Maximum On-Resistance
- 75 $\mu$ A On-State Supply Current
- 1 $\mu$ A Shutdown Current
- Output can be Forced Higher than Input (Off-State)
- Thermal Shutdown
- Slow Turn On and Fast Turn Off
- Active-high Version: SP2525A-1
- Active-low Version: SP2525A-2
- RoHS Compliant, Green/Halogen Free 8-Pin NSOIC Package

## TYPICAL APPLICATION DIAGRAM

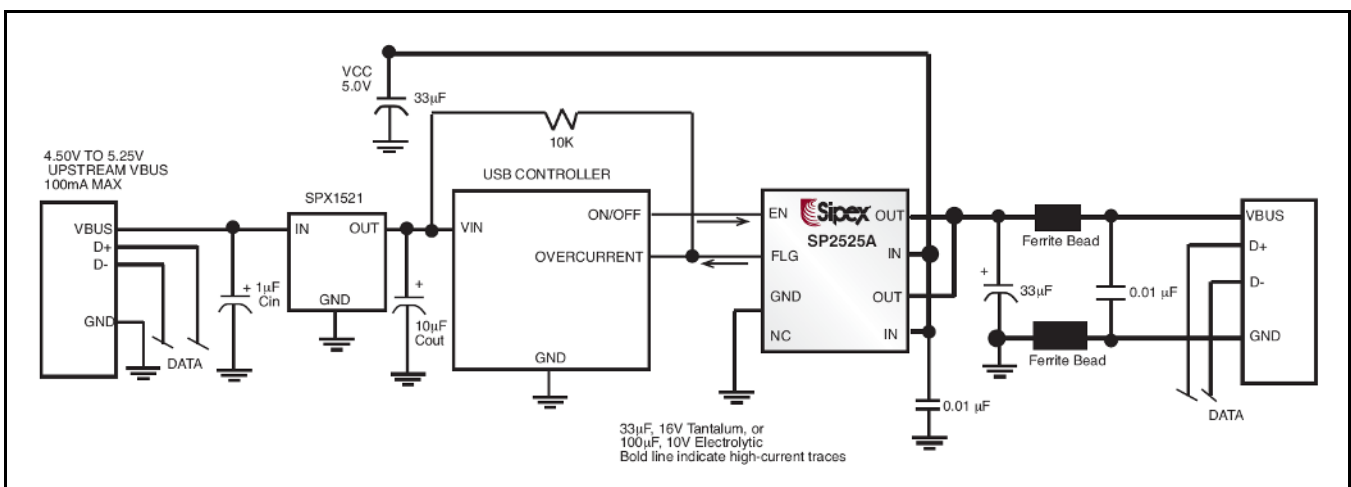

Fig. 1: SP2525A Application Diagram – Single Port Self Powered Hub



**Single Channel USB Power Distribution Switch**

**ABSOLUTE MAXIMUM RATINGS**

These are stress ratings only and functional operation of the device at these ratings or any other above those indicated in the operation sections of the specifications below is not implied. Exposure to absolute maximum rating conditions for extended periods of time may affect reliability.

Supply Voltage  $V_{IN}$ ..... 7.0V  
 Fault Flag Voltage  $V_{FLG}$  ..... 7.0V  
 Fault Flag Current  $I_{FLG}$  .....50mA  
 Enable Input  $V_{EN}$ ..... -0.3V to 15V  
 Storage Temperature..... -65°C to 150°C  
 Power Dissipation (NSOIC-8) .....  
 (derate 6.14mW/°C above 70°C)..... 500mW

**OPERATING RATINGS**

Ambient Temperature Range..... -40°C to 85°C

**ELECTRICAL SPECIFICATIONS**

Specifications with standard type are for an Operating Ambient Temperature of  $T_A = 25^\circ\text{C}$  only; limits applying over the full Operating Junction Temperature range are denoted by a "•". Minimum and Maximum limits are guaranteed through test, design, or statistical correlation. Typical values represent the most likely parametric norm at  $T_A = 25^\circ\text{C}$ , and are provided for reference purposes only. Unless otherwise indicated,  $V_{IN} = 5.0\text{V}$ ,  $T_A = 25^\circ\text{C}$ .

| Parameter                           | Min. | Typ. | Max. | Units            | Conditions                                   |
|-------------------------------------|------|------|------|------------------|--|
| Supply Current                      |      | 0.75 | 5.0  | $\mu\text{A}$    | $V_{EN} = \text{Logic "0"}$ OUT =open        |
|                                     |      | 75   | 100  |                  | $V_{EN} = \text{Logic "1"}$ OUT =open        |
| Enable Input Voltage                | 0.8  | 1.7  |      | V                | $V_{EN} = \text{Logic "0"}$                  |
|                                     |      | 2.0  | 2.4  |                  | $V_{EN} = \text{Logic "1"}$                  |
| Enable Input Current                |      | 0.01 | 1    | $\mu\text{A}$    | $V_{EN} = \text{Logic "0"}$                  |
|                                     |      | 0.01 | 1    |                  | $V_{EN} = \text{Logic "1"}$                  |
| Enable Input Capacitance            |      | 1    |      | pF               |  |
| Output MOSFET Resistance            |      | 70   | 100  | m $\Omega$       |  |
| Output turn-on delay                |      | 100  |      | $\mu\text{s}$    | $R_L = 10\Omega$ , each output               |
| Output turn-on rise time            |      | 1000 | 4000 | $\mu\text{s}$    | $R_L = 10\Omega$ , each output               |
| Output turn-off delay               |      | 0.8  | 20   | $\mu\text{s}$    | $R_L = 10\Omega$ , each output               |
| Output turn-off fall time           |      | 0.7  | 20   | $\mu\text{s}$    | $R_L = 10\Omega$ , each output               |
| Output Leakage Current              |      |      | 10   | $\mu\text{A}$    |  |
| Current limit threshold             | 0.6  | 1.0  | 1.25 | A                |  |
| Over temperature shutdown threshold |      | 135  |      | $^\circ\text{C}$ | Temperature $T_J$ raising                    |
|                                     |      | 125  |      |                  | Temperature $T_J$ decreasing                 |
| Error Flag Output Resistance        |      | 10   | 25   | $\Omega$         | $V_{IN} = 5\text{V}$ , $I_L = 10\text{mA}$   |
|                                     |      | 15   | 40   |                  | $V_{IN} = 3.3\text{V}$ , $I_L = 10\text{mA}$ |
| Error Flag Current                  |      | 0.01 | 1    | $\mu\text{A}$    |  |
| UVLO threshold                      |      | 2.6  |      | V                | $V_{IN}$ increasing                          |
|                                     |      | 2.4  |      |                  | $V_{IN}$ decreasing                          |

**BLOCK DIAGRAM**

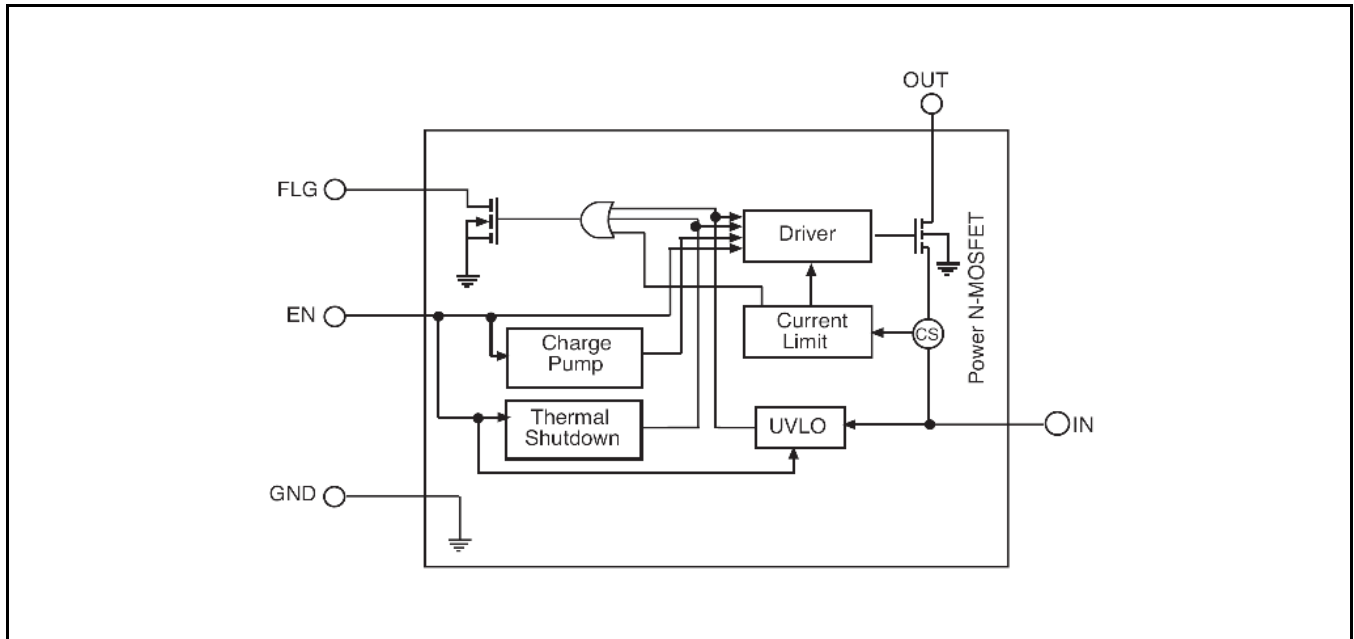

Fig. 2: SP2525A Block Diagram

**PIN ASSIGNMENT**

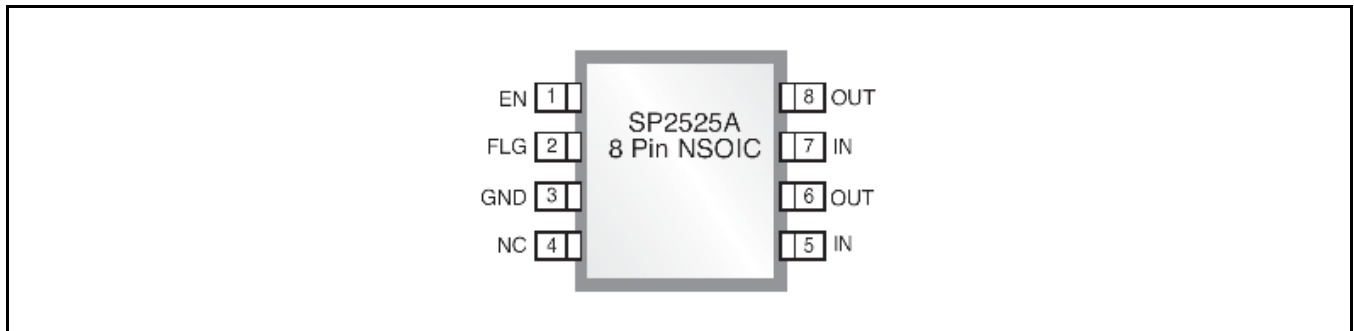

Fig. 3: SP2525A Pin Assignment

**PIN DESCRIPTION**

| Name | Pin Number | Description   |
|------|------------|---|
| EN   | 1          | Enable Input Active High for SP2525A-1 and Active Low for SP2525A-2   |
| FLG  | 2          | An active-low and open-drained fault flag output for power switch. It can indicate current limit if CTL is active. In normal mode operation, it also can indicate thermal shutdown or under voltage |
| GND  | 3          | Chip Power Ground   |
| NC   | 4          | Not Internally Connected  |
| IN   | 5, 7       | Power Supply Input  |
| OUT  | 6, 8       | MOSFET Switch Output  |



**ORDERING INFORMATION<sup>(1)</sup>**

| <b>Part Number</b> | <b>Temperature Range</b>       | <b>Package</b> | <b>Packing Method</b> | <b>Lead-Free<sup>(2)</sup></b> | <b>Note 1</b>      |
|--------------------|--------------------------------|----------------|-----------------------|--------------------------------|--------------------|
| SP2525A-1EN-L/TR   | -40°C ≤ T <sub>A</sub> ≤ +85°C | NSOIC8         | Tape & Reel           | Yes                            | Enable Active High |
| SP2525A-2EN-L/TR   | -40°C ≤ T <sub>A</sub> ≤ +85°C | NSOIC8         | Tape & Reel           | Yes                            | Enable Active Low  |

Notes:

1. Refer to [www.maxlinear.com/SP2525A](http://www.maxlinear.com/SP2525A) for most up-to-date Ordering Information.
2. Visit [www.maxlinear.com](http://www.maxlinear.com) for additional information on Environmental Rating.

**TYPICAL PERFORMANCE CHARACTERISTICS**

All data taken at  $V_{IN} = 5.0V$ ,  $T_A = 25^\circ C$ , unless otherwise specified - Schematic and BOM from Application Information section of this datasheet.

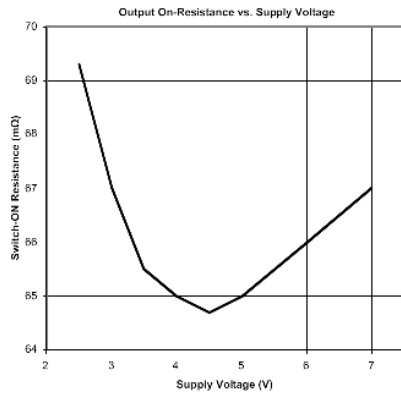

Fig. 4: Output On-Resistance vs Supply Voltage

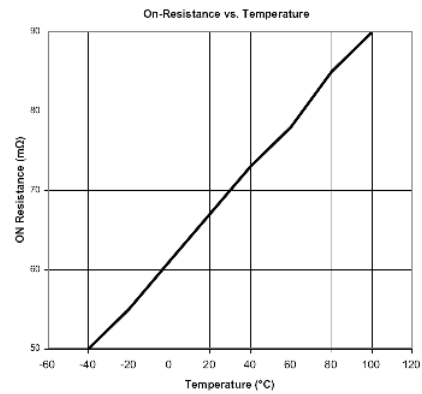

Fig. 5: Output On-Resistance vs Temperature

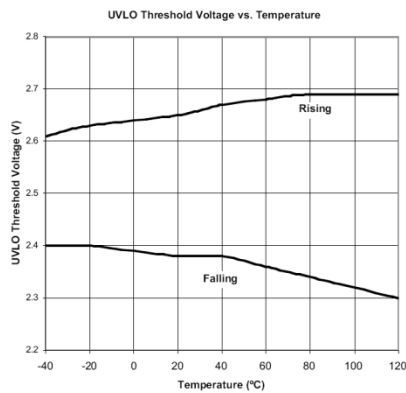

Fig. 6: UVLO Threshold vs Temperature

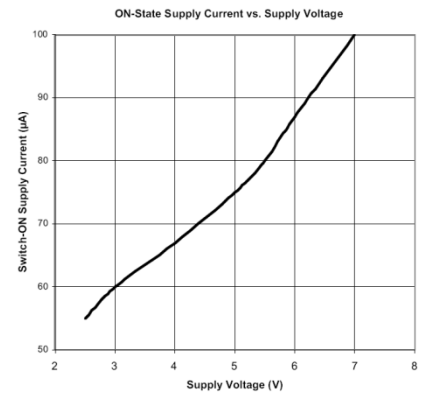

Fig. 7: On-state Supply Current vs Supply Voltage

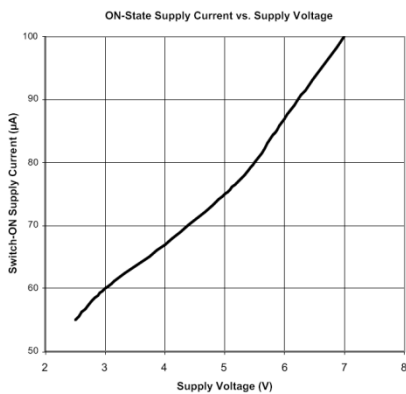

Fig. 8: On-state Supply Current vs Temperature

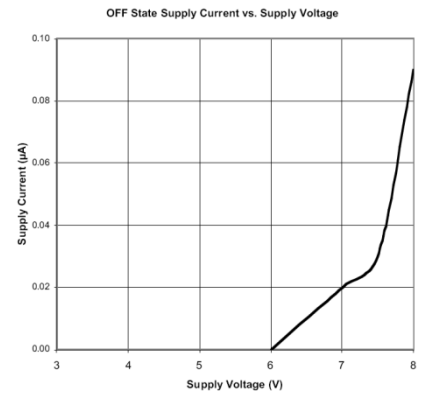

Fig. 9: Off-state Supply Current vs Supply Voltage

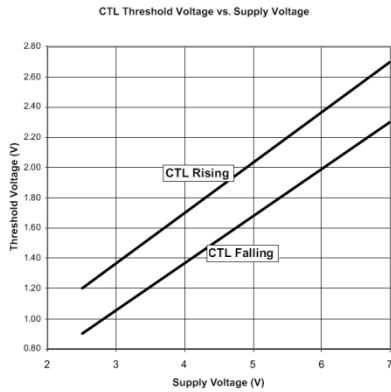

Fig. 10: CTL Threshold vs Supply Voltage

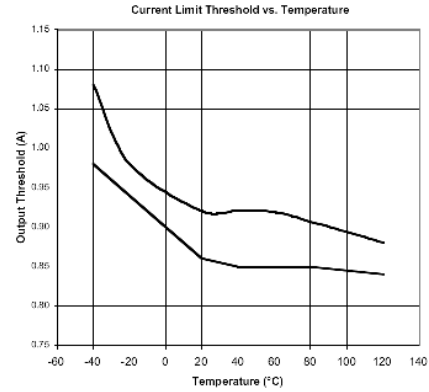

Fig. 11: Current Limit Threshold vs Temperature

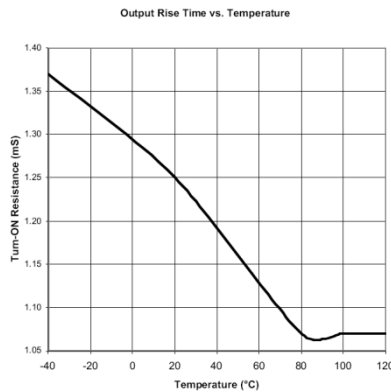

Fig. 12: Output Rise Time vs Temperature

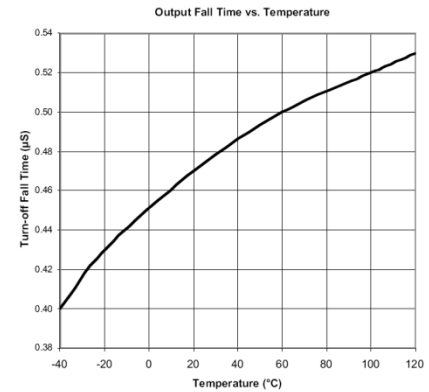

Fig. 13: Output Fall Time vs Temperature

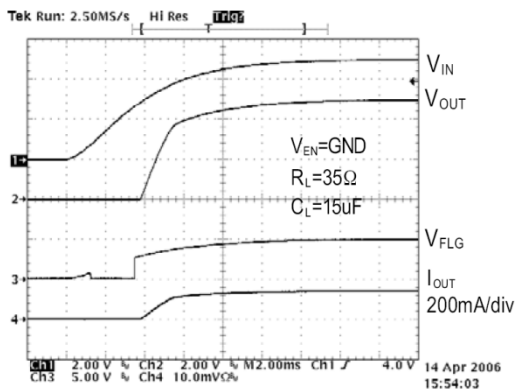

Fig. 14: Input Voltage Response

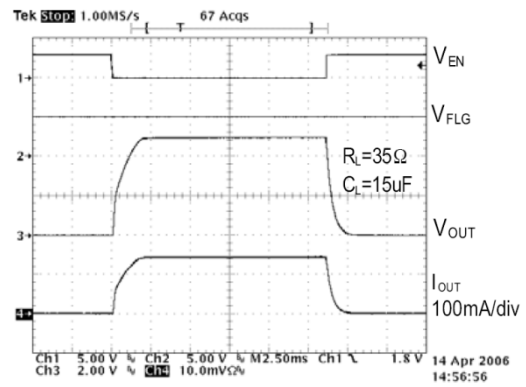

Fig. 15: Turn-On, Turn-Off Characteristics

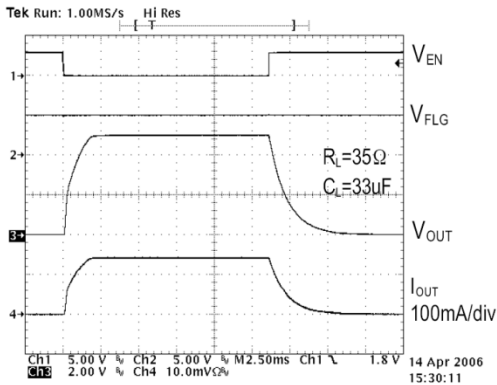

Fig. 16: Turn-On, Turn-Off Characteristics

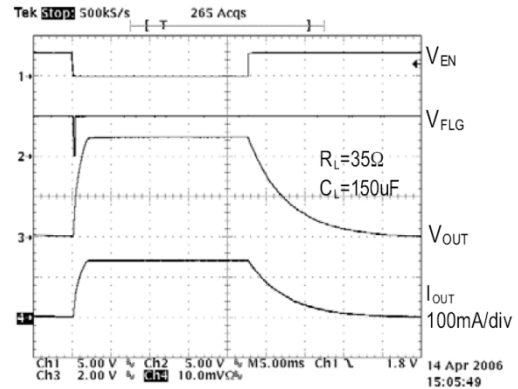

Fig. 17: Turn-On, Turn-Off Characteristics

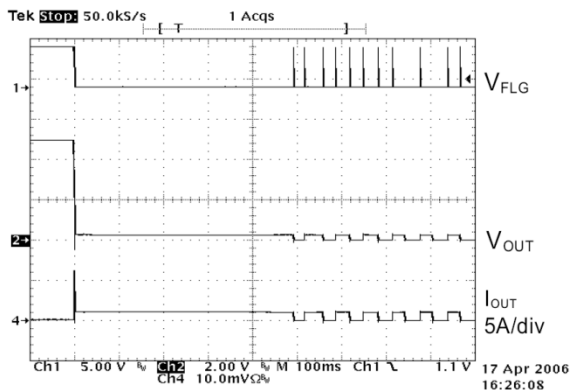

Fig. 18: Short Circuit Response (Short applied to Output)

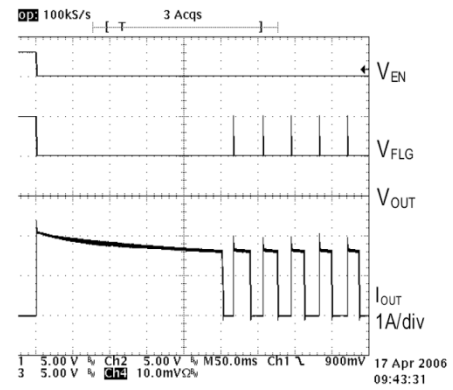

Fig. 19: Short Circuit Response (Enable to Short Circuit)

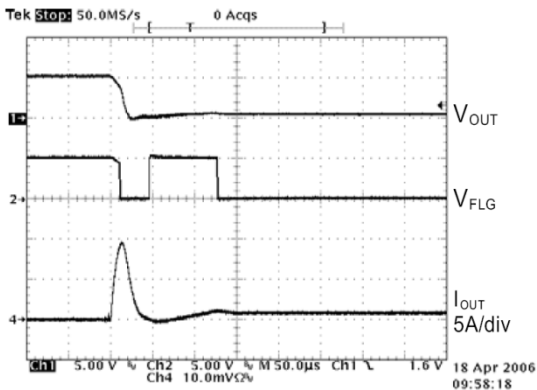

Fig. 20: Short Circuit Transient Response (Short applied to Output)

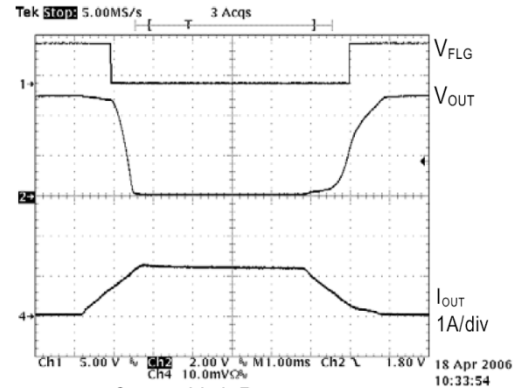

Fig. 21: Current Limit Response (Ramped Load)

## APPLICATION INFORMATION

### ERROR FLAG

The Error Flag is an open-drained output of an N-channel MOSFET, the FLG output is pulled low to signal the following fault conditions: input undervoltage, output current limit, and thermal shutdown.

### CURRENT LIMIT

The current limit threshold is preset internally. It protects the output MOSFET switches from damage resulting from undesirable short circuit conditions or excess inrush current, which is often encountered during hot plug-in. The low limit of the current limit threshold of the SP2525A allows a minimum current of 0.5A through the MOSFET switches. A current limit condition will signal the Error Flag.

### THERMAL SHUTDOWN

When the temperature of the SP2525A exceeds 135°C for any reasons, the thermal shutdown function turns off the MOSFET switch and signals the Error Flag. A hysteresis of 10°C prevents the MOSFETs from turning back on until the chip temperature drops below 125°C.

### SUPPLY FILTERING

A 0.1µF to 1µF bypass capacitor from IN to GND, located near the device, is strongly recommended to control supply transients. Without a bypass capacitor, an output short may cause ringing on the input (from supply lead inductance) which can damage internal control circuitry.

### TRANSIENT REQUIREMENTS

USB supports dynamic attachment (hot plugin) of peripherals. A current surge is caused by the input capacitance of a downstream device. Ferrite beads are recommended in series with all power and ground connector pins. Ferrite beads reduce EMI and limit the inrush current during hot-attachment by filtering high-frequency signals.

### SHORT CIRCUIT TRANSIENT

Bulk capacitance provides the short-term transient current needed during a hot-attachment event. A 33µF/16V tantalum or a 100µF/ 10V electrolytic capacitor mounted close to the downstream connector at each port should provide sufficient transient drop protection.

### PRINTED CIRCUIT LAYOUT

The Power circuitry of USB printed circuit boards requires a customized layout to maximize thermal dissipation and to minimize voltage drop and EMI.

### INPUT AND OUTPUT

The independent solid state switch connects the IN pin to the OUT pin when enabled by a logic signal at EN. The IN pin is the power supply connection to the internal circuitry and the drain of the output MOSFET. The OUT pin is the source for the MOSFET. Typically, the current in USB application will flow through the switch from IN to OUT towards the load. If VOUT is greater than VIN when a switch is enabled, the current will flow from OUT to the IN pin because the MOSFET channels are bidirectional when switched on. The output source is allowed to be externally forced to a higher voltage than its input without causing unwanted current flow when the output is disabled.

### TEST CIRCUIT

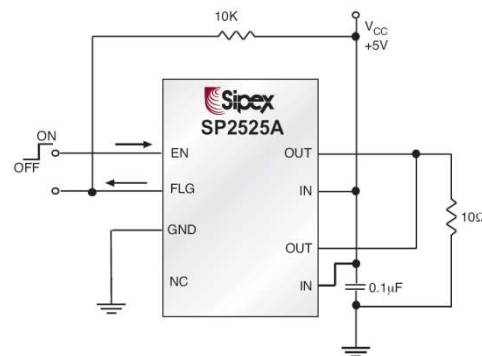



**PACKAGE SPECIFICATION**

**8-PIN NSOIC**

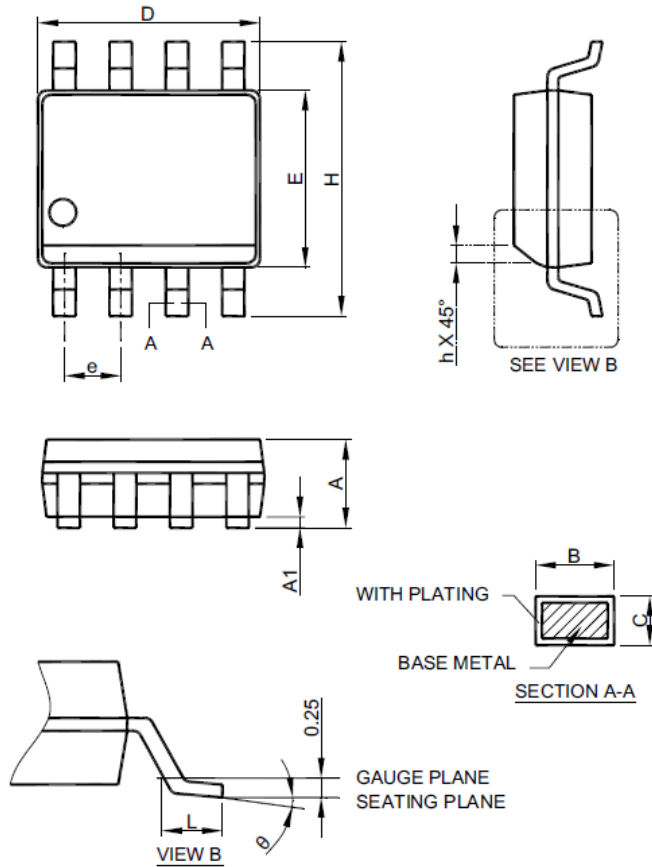

- Note: 1. Refer to JEDEC MS-012AA.  
 2. Dimension "D" does not include mold flash, protrusions or gate burrs. Mold flash, protrusion or gate burrs shall not exceed 6 mil per side.  
 3. Dimension "E" does not include inter-lead flash or protrusions.  
 4. Controlling dimension is millimeter, converted inch dimensions are not necessarily exact.

| SYMBOL   | 8 PIN SOICN |      |
|----------|-------------|------|
|          | MILLIMETERS |      |
|          | MIN.        | MAX. |
| A        | 1.35        | 1.75 |
| A1       | 0.10        | 0.25 |
| B        | 0.33        | 0.51 |
| C        | 0.19        | 0.25 |
| D        | 4.80        | 5.00 |
| E        | 3.80        | 4.00 |
| e        | 1.27 BSC    |      |
| H        | 5.80        | 6.20 |
| h        | 0.25        | 0.50 |
| L        | 0.40        | 1.27 |
| $\theta$ | 0°          | 8°   |



**REVISION HISTORY**

| Revision | Date       | Description  |
|----------|------------|--|
| 2.0.0    | 11/10/2010 | Reformat of datasheet                                    |
| 2.1.0    | 11/04/2011 | Updated package specification                            |
| 2.1.1    | 1/22/2020  | Updated to MaxLinear logo. Updated Ordering Information. |



**CORPORATE HEADQUARTERS:**

5966 La Place Court  
Suite 100  
Carlsbad, CA 92008  
Tel.: +1 (760) 692-0711  
Fax: +1 (760) 444-8598  
[www.maxlinear.com](http://www.maxlinear.com)

The content of this document is furnished for informational use only, is subject to change without notice, and should not be construed as a commitment by Maxlinear, Inc. Maxlinear, Inc. Assumes no responsibility or liability for any errors or inaccuracies that may appear in the informational content contained in this guide. Complying with all applicable copyright laws is the responsibility of the user. Without limiting the rights under copyright, no part of this document may be reproduced into, stored in, or introduced into a retrieval system, or transmitted in any form or by any means (electronic, mechanical, photocopying, recording, or otherwise), or for any purpose, without the express written permission of Maxlinear, Inc.

Maxlinear, Inc. Does not recommend the use of any of its products in life support applications where the failure or malfunction of the product can reasonably be expected to cause failure of the life support system or to significantly affect its safety or effectiveness. Products are not authorized for use in such applications unless Maxlinear, Inc. Receives, in writing, assurances to its satisfaction that: (a) the risk of injury or damage has been minimized; (b) the user assumes all such risks; (c) potential liability of Maxlinear, Inc. Is adequately protected under the circumstances.

Maxlinear, Inc. May have patents, patent applications, trademarks, copyrights, or other intellectual property rights covering subject matter in this document. Except as expressly provided in any written license agreement from Maxlinear, Inc., the furnishing of this document does not give you any license to these patents, trademarks, copyrights, or other intellectual property.

Maxlinear, the Maxlinear logo, and any Maxlinear trademarks, MxL, Full-Spectrum Capture, FSC, G.now, AirPHY and the Maxlinear logo are all on the products sold, are all trademarks of Maxlinear, Inc. or one of Maxlinear's subsidiaries in the U.S.A. and other countries. All rights reserved. Other company trademarks and product names appearing herein are the property of their respective owners.

© 2011 - 2020 Maxlinear, Inc. All rights reserved.