

THIS DRAWING IS UNPUBLISHED. RELEASED FOR PUBLICATION ,1988 .
 © COPYRIGHT 19 BY AMP INCORPORATED. ALL INTERNATIONAL RIGHTS RESERVED.

LOC		DIST		P		F		ZONE		LTR		REVISIONS		DATE	APPD
DF	50											D	REV PER 0600-8279-99	1-00	CT

1. THIS RECEPTACLE IS HERMETICALLY SEALED.
2. SCREW THREAD MEASUREMENTS IN ACCORDANCE WITH H28 HANDBOOK. (3 WIRE METHOD). USING WIRE .01804 DIAMEASUREMENT OVER WIRE SHALL BE .318/.307.

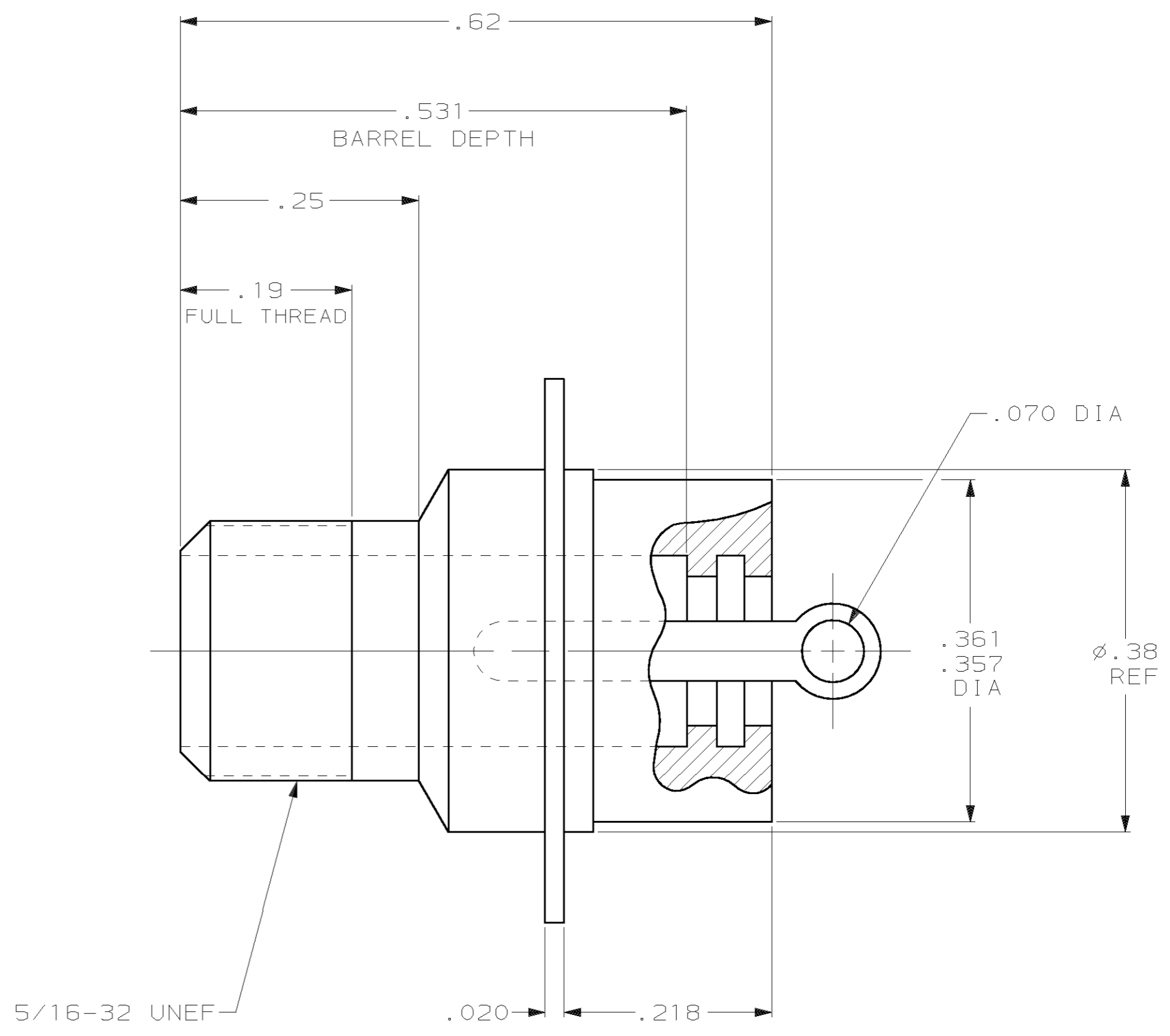
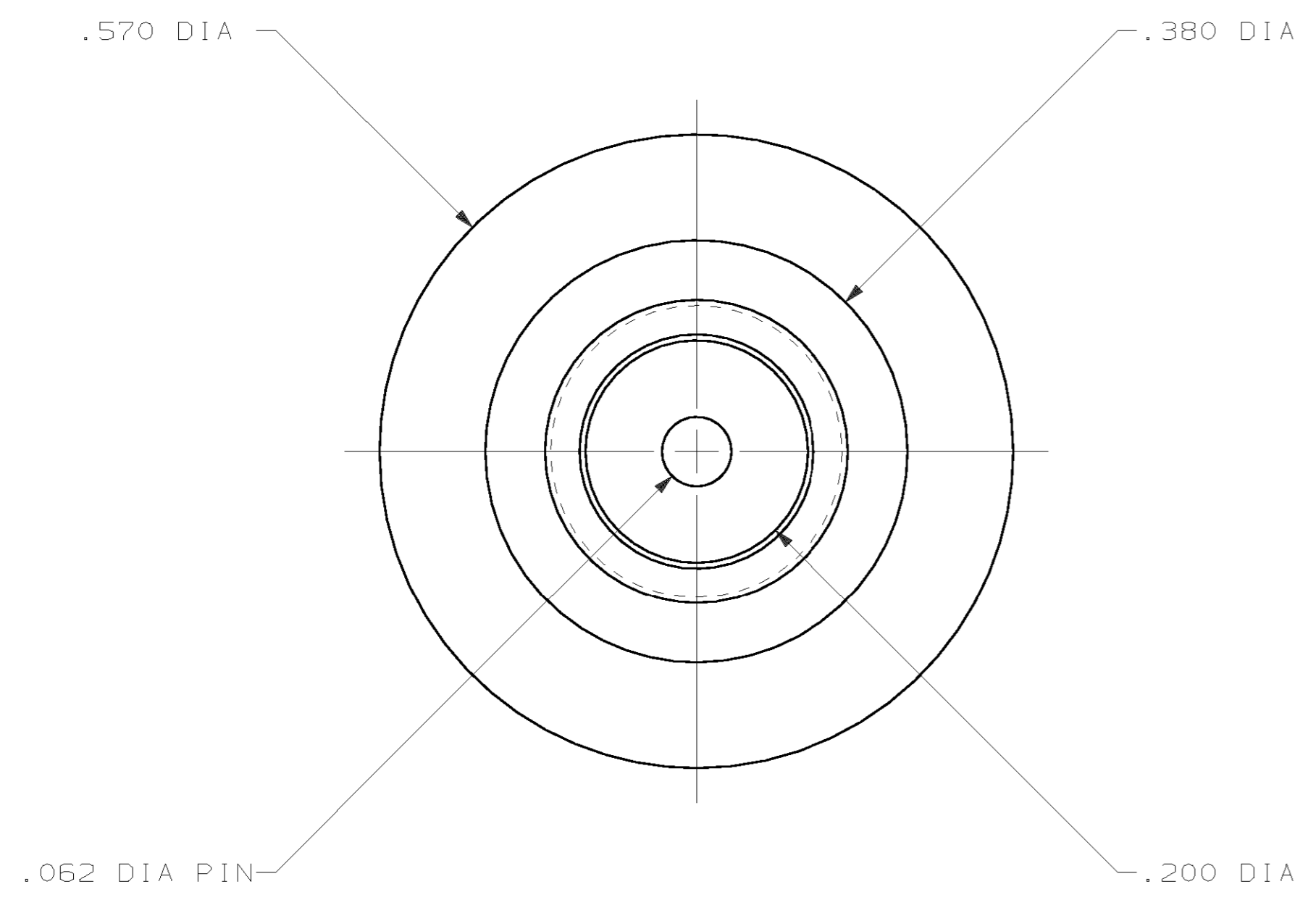

FINISH	PART NO
GOLD, .000050 IN. THICK	865909-3
GOLD, .000030 IN. THICK	865909-1

DO NOT SCALE PRINT. UNLESS SPECIFIED DIMENSIONS IN INCHES TOLERANCES ON : 2 PLC DEC ± .01 3 PLC DEC ± .005 ANGLES ± _____ MATERIAL MOLDED GLASS EPOXY FINISH SEE TABLE	DR <i>J. Shuy</i> 2-17-88 CHK 2-18-88 M. GARDNER APPD 2-18-88 M. GARDNER APPD 2-18-88 M. GARDNER PRODUCT SPEC - APPLICATION SPEC - WEIGHT -	AMP INCORPORATED Harrisburg, Pa. 17105		
	NAME RECEPTACLE, FLANGED, LGH-1/2		DRAWING NO 865909	
	SIZE C	FSCM NO 00779	SHEET 1 OF 1	
	SCALE 8:1	SHEET 1 OF 1		

865909