

CONSTANT VOLTAGE AND CONSTANT CURRENT CONTROLLER

NEW PRODUCT

Description

AP4312Q is an Automotive Grade product that is AEC-Q100 grade 1 qualified. It is a highly integrated solution for the constant voltage/constant current mode SMPS application and linear DC/DC regulator (used in Automotive application).

The AP4312Q contains one 1.21V voltage reference, one low voltage reference used in current sensing circuit and two operational amplifiers. The 1.21V voltage reference, combined with one operational amplifier, makes of an ideal voltage controller for use in adapters and battery chargers. The low voltage reference, combined with another operational amplifier, makes of an ideal current limiter for output low side current sensing.

The AP4312Q is fully compatible with AP4306 in functionality and electrical characteristics except its lower reference voltage for current control loop, thus higher power efficiency in SMPS applications such as low power charger can be realized with AP4312Q compared to AP4306.

The AP4312Q is available in SOT26 package.

Features

- Constant Voltage and Constant Current Control
- Precision Internal Voltage Reference
- Low External Component Count
- Easy Compensation
- Low Supply Current: 180µA
- Current Control Loop Reference: 70mV
- Operating Supply Voltage: 1.7V to 18V
- **Totally Lead-free & Fully RoHS Compliant (Notes 1 & 2)**
- **Halogen and Antimony Free. "Green" Device (Note 3)**

Notes: 1. No purposely added lead. Fully EU Directive 2002/95/EC (RoHS) & 2011/65/EU (RoHS 2) compliant.
 2. See http://www.diodes.com/quality/lead_free.html for more information about Diodes Incorporated's definitions of Halogen- and Antimony-free, "Green" and Lead-free.
 3. Halogen- and Antimony-free "Green" products are defined as those which contain <900ppm bromine, <900ppm chlorine (<1500ppm total Br + Cl) and <1000ppm antimony compounds.

Pin Assignments

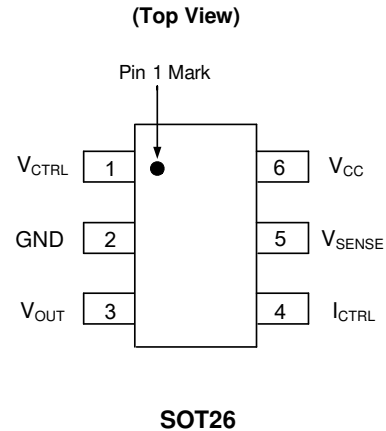

Applications

- Adapters
- Battery Chargers
- Automotive

Typical Applications Circuit

NEW PRODUCT

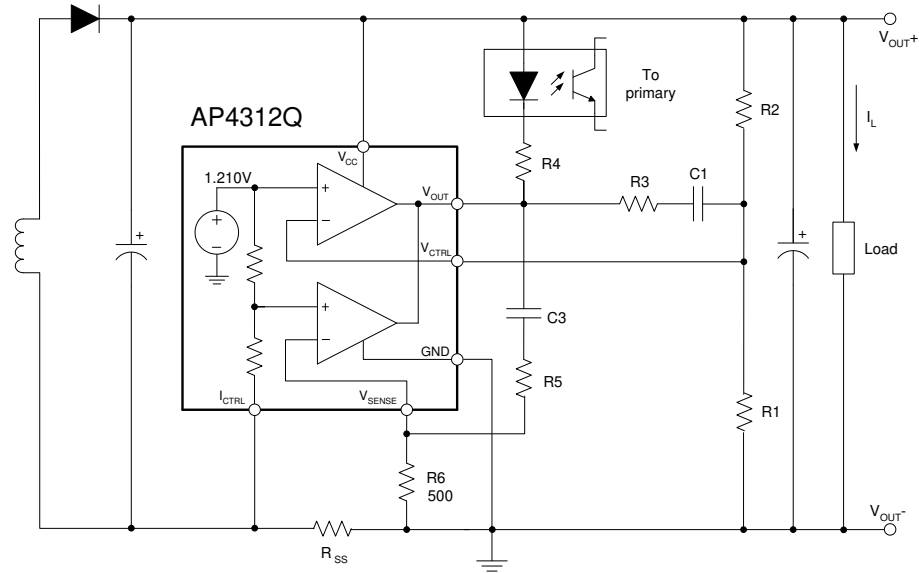

$$V_{OUT} = V_{REF} \times \frac{R1 + R2}{R1}$$

$$CurrentLimit = \frac{V_{SENSE}}{R_{SS}}$$

Typical Application 1

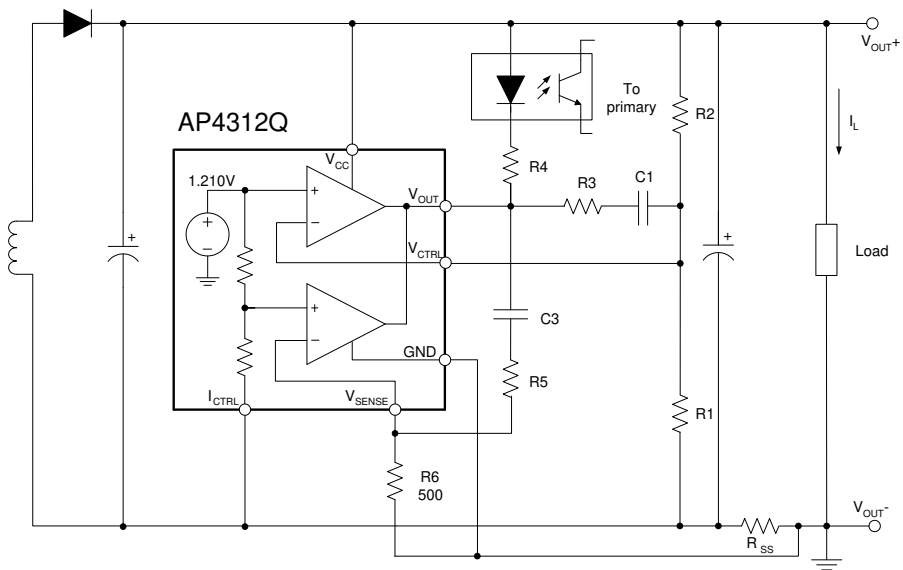

$$V_{OUT} = [V_{REF} + (I_L \times R_{SS})] \times \frac{R1 + R2}{R1} - (I_L \times R_{SS})$$

$$CurrentLimit = \frac{V_{SENSE}}{R_{SS}}$$

Typical Application 2

Typical Applications Circuit (Cont.)

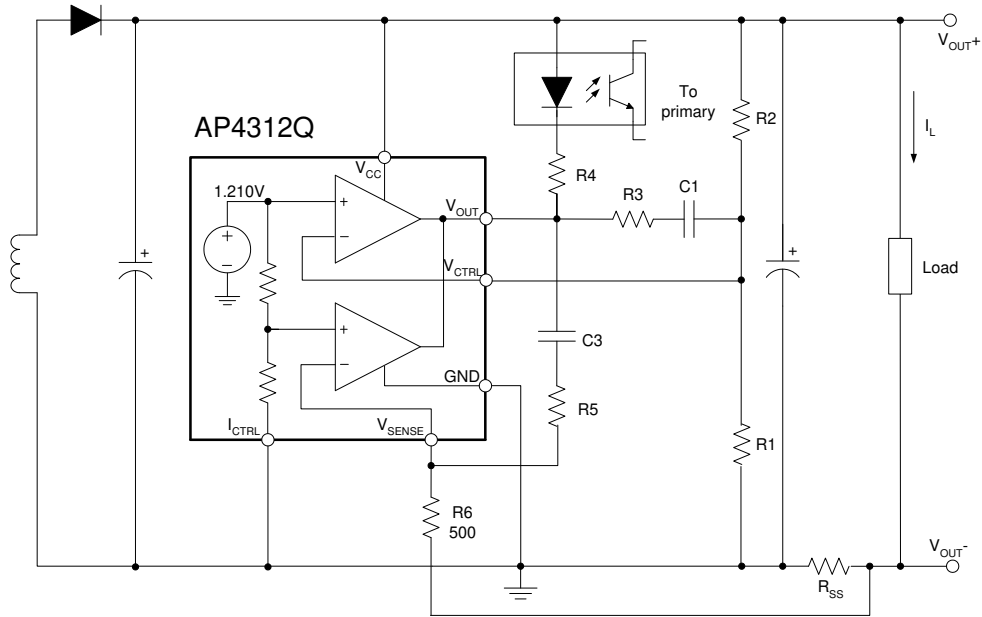

$$V_{OUT} = V_{REF} \times \frac{R1 + R2}{R1} - (I_L \times R_{SS})$$

$$CurrentLimit = \frac{V_{SENSE} \times V_{REF}}{(V_{SENSE} + V_{REF}) \times R_{SS}}$$

Typical Application 3

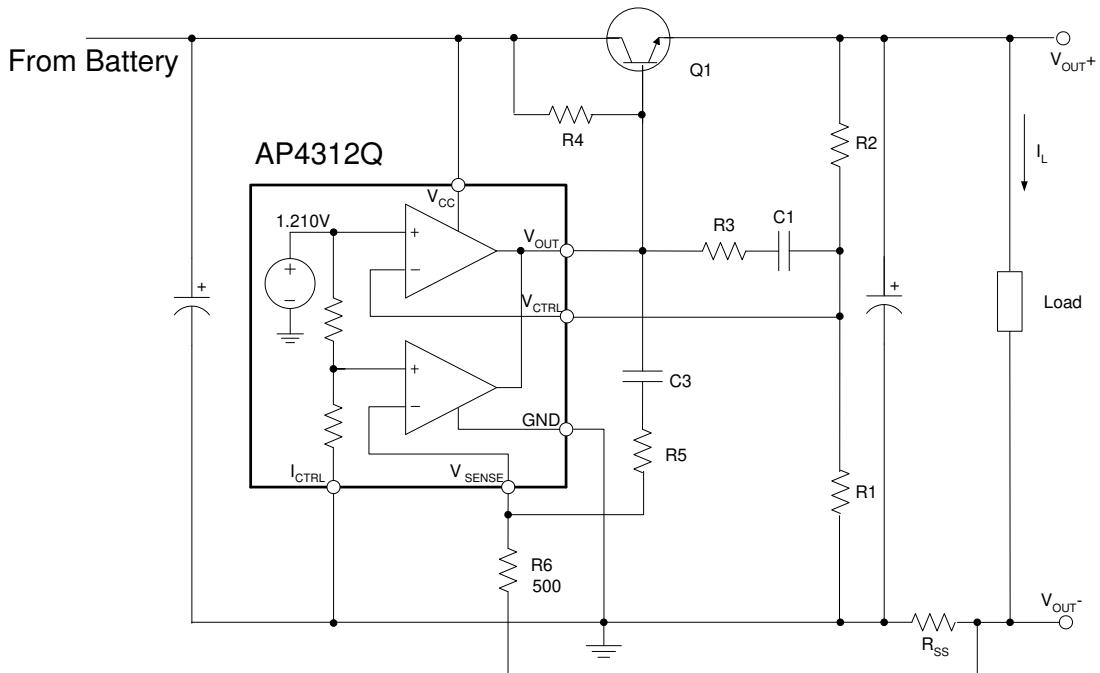

Typical Application 4

$$V_{OUT} = V_{REF} \times \frac{R1 + R2}{R1} - (I_L \times R_{SS})$$

$$CurrentLimit = \frac{V_{SENSE} \times V_{REF}}{(V_{SENSE} + V_{REF}) \times R_{SS}}$$

NEW PRODUCT

Pin Descriptions

Pin Number	Pin Name	Function
1	V _{CTRL}	Input pin of the voltage control loop
2	GND	Ground
3	V _{OUT}	Output pin. Sinking current only
4	I _{CTRL}	Input pin of the current control loop
5	V _{SENSE}	Input pin of the current control loop
6	V _{CC}	Power Supply

Functional Block Diagram

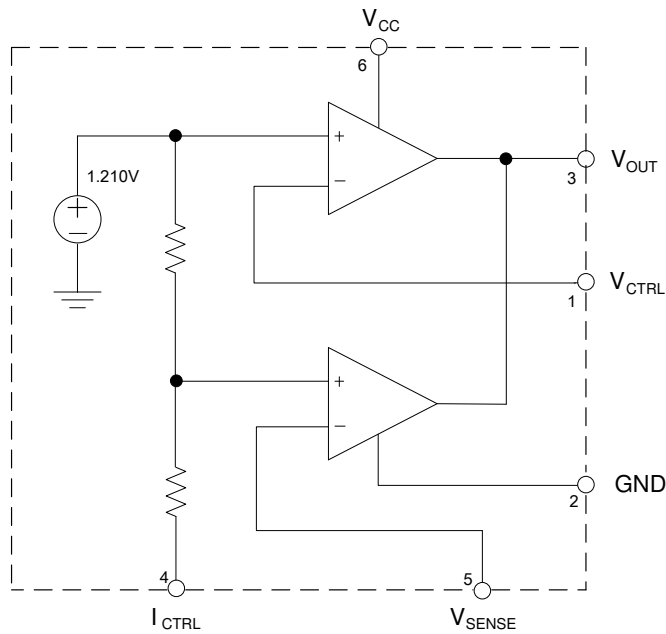

Absolute Maximum Ratings (Note 4)

Symbol	Parameter	Rating	Unit
V _{CC}	Power Supply Voltage	20	V
V _{IN}	Input Voltage	-0.3 to V _{CC}	V
T _J	Junction Temperature	+150	°C
T _{STG}	Storage Temperature	-65 to +150	°C
T _{LEAD}	Lead Temperature (Soldering, 5sec)	+260	°C
θ _{JA}	Thermal Resistance (Junction to Ambient)	250	°C/W

Note 4: Stresses greater than those listed under "Absolute Maximum Ratings" may cause permanent damage to the device. These are stress ratings only, and functional operation of the device at these or any other conditions beyond those indicated under "Recommended Operating Conditions" is not implied. Exposure to "Absolute Maximum Ratings" for extended periods may affect device reliability.

Recommended Operating Conditions

Symbol	Parameter	Min	Max	Unit
V _{CC}	Power Supply Voltage	1.7	18	V

Electrical Characteristics (@V_{CC}=5V, T_A=+25°C, unless otherwise specified.)

Symbol	Parameters	Conditions	Min	Typ	Max	Unit
TOTAL CURRENT CONSUMPTION						
I _{CC}	Total Supply Current Not Including the Output Sinking Current	T _A =+25°C	-	180	-	μA
		-40°C < T _A < +105°C	-	-	300	
VOLTAGE CONTROL LOOP						
G _{mv}	Transconductance of Voltage Control Loop Op-Amp (Sink Current Only)	T _A =+25°C	1	3.5	-	mA/mV
		-40°C < T _A < +105°C	-	2.5	-	
V _{REF}	Voltage Control Loop Reference	T _A =+25°C	1.204	1.21	1.216	V
		-40°C < T _A < +105°C	1.186		1.234	
I _{IBV}	Input Bias Current (V _{CTRL})	T _A =+25°C	-	50	-	nA
		-40°C < T _A < +105°C	-	100	-	
CURRENT CONTROL LOOP						
G _{mi}	Transconductance of Current Control Loop Op-Amp (Sink Current Only)	T _A =+25°C	1.5	7	-	mA/mV
		-40°C < T _A < +105°C	1.5	7	-	
V _{SENSE}	Current Control Loop Reference	T _A =+25°C	67.9	70	72.1	mV
		-40°C < T _A < +105°C	66		74	
I _{IBI}	Current Out of Pin I _{CTRL} at V _{SENSE}	T _A =+25°C	-	18	-	μA
		-40°C < T _A < +105°C	-	35	-	
OUTPUT STAGE						
V _{OL}	Low Output Voltage Level	T _A =+25°C, I _{SINK} =2mA	-	100	-	mV
		-40°C < T _A < +105°C, I _{SINK} =2mA	-	100	-	
I _{OS}	Output Short Circuit Current. Output to V _{CC} . Sink Current Only	T _A =+25°C	-	27	50	mA
		-40°C < T _A < +105°C	-	35	-	

Thermal Impedance

Symbol	Parameter	Value	Unit
θ _{JC}	Thermal Resistance (Junction to Case)	84	°C/W

Performance Characteristics

NEW PRODUCT

Voltage Control Loop Reference vs. Ambient Temperature

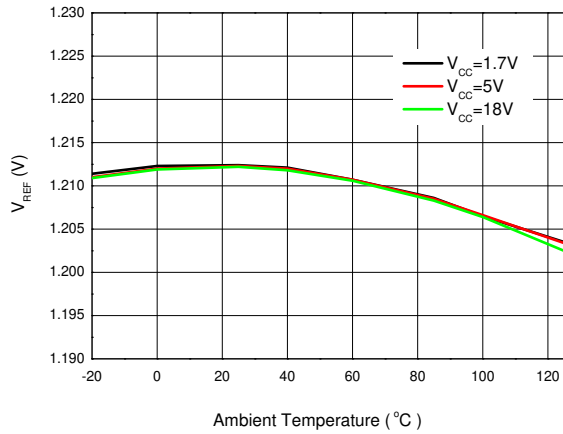

Current Control Loop Reference vs. Ambient Temperature

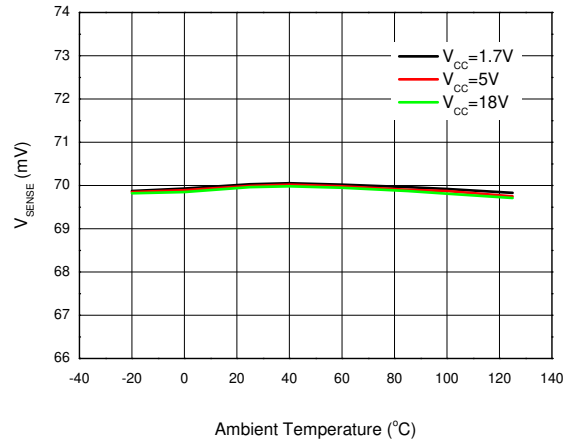

Input Bias Current (V_{CTRL}) vs. Ambient Temperature

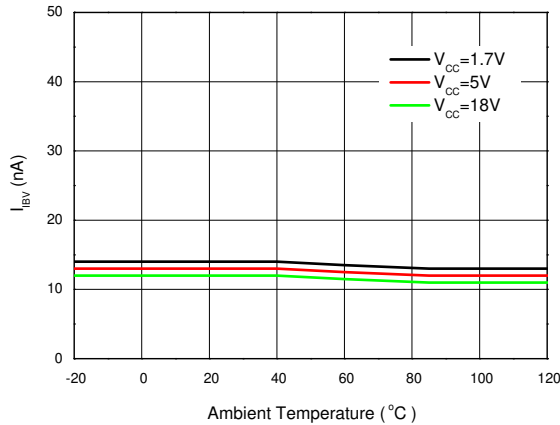

Current Out of Pin I_{CTRL} at V_{SENSE} vs. Ambient Temperature

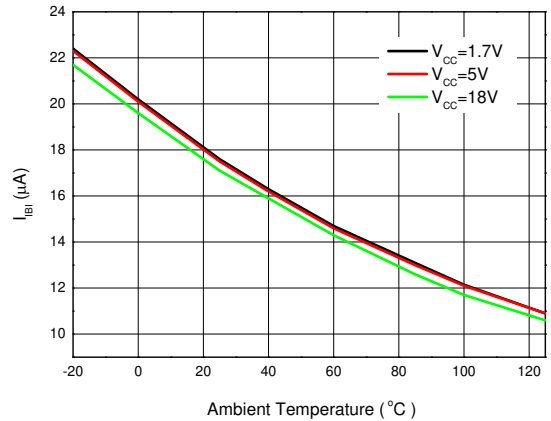

Transconductance of Voltage Control Loop Op-Amp vs. Ambient Temperature

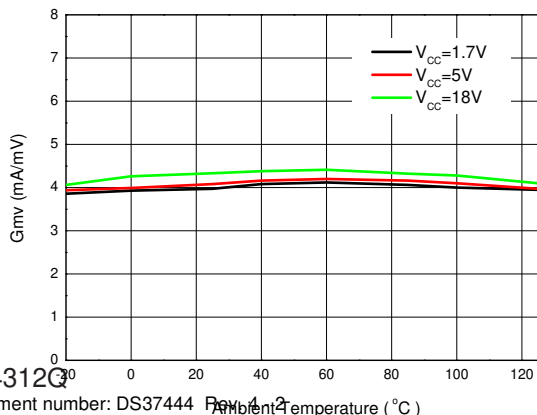

Transconductance of Current Control Loop Op-Amp vs. Ambient Temperature

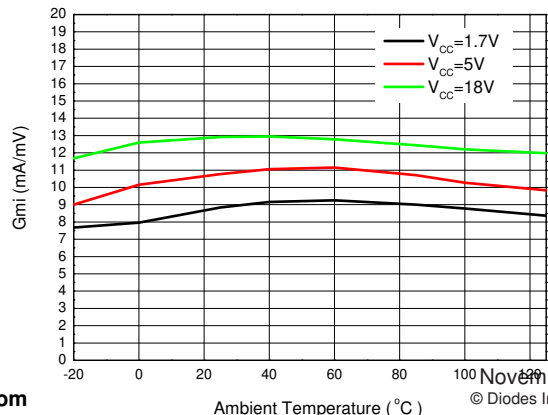

Performance Characteristics (Cont.)

Low Output Level of Voltage Control Loop Op-Amp vs. Ambient Temperature

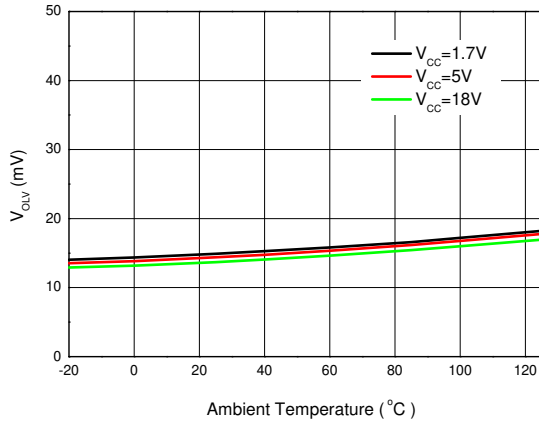

Low Output Level of Current Control Loop Op-Amp vs. Ambient Temperature

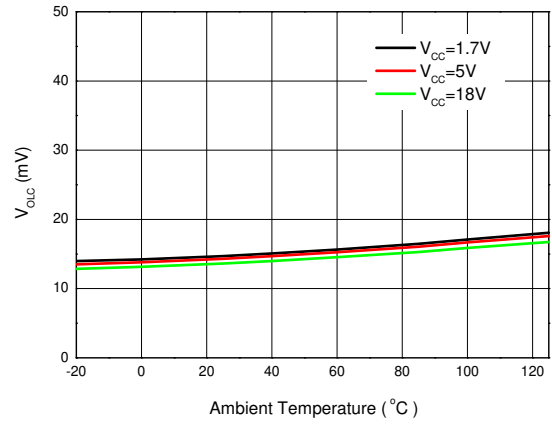

Output Short Circuit Current of Voltage Control Loop Op-Amp vs. Ambient Temperature

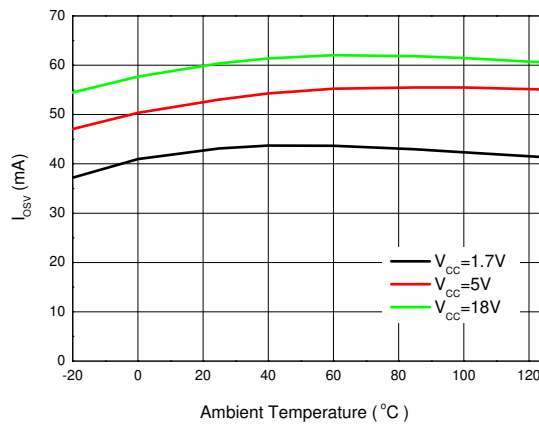

Output Short Circuit Current of Current Control Loop Op-Amp vs. Ambient Temperature

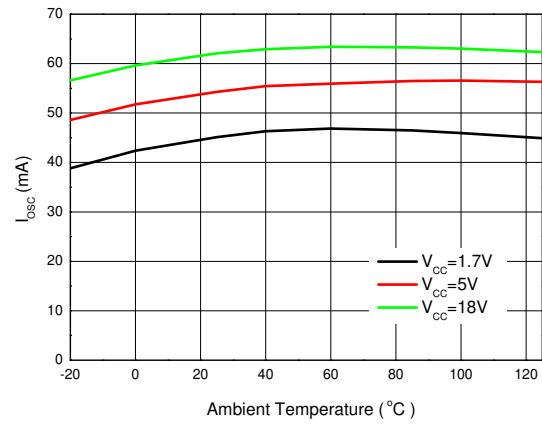

Total Supply Current Not Including the Output Sinking Current vs. Ambient Temperature

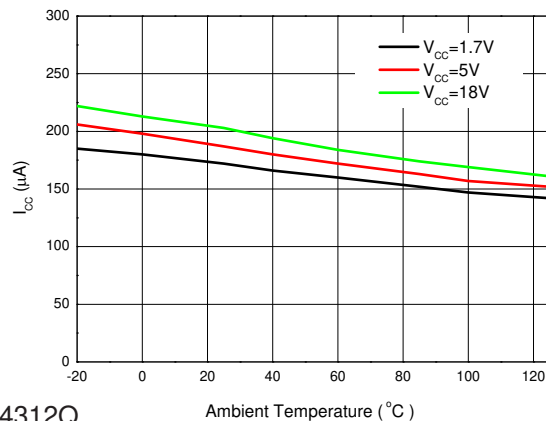

Low Output Voltage Level vs. Sink Current

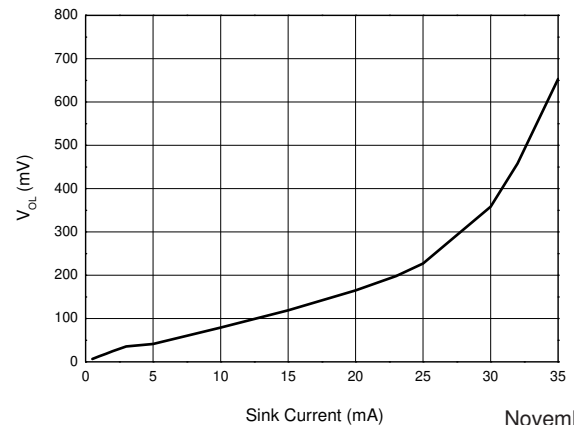

Ordering Information

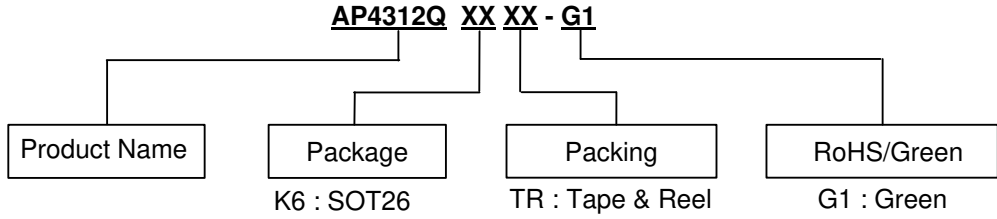

Package	Part Number	Marking ID	Packing
SOT26	AP4312QK6TR-G1	GKD	3000/Tape & Reel

Marking Information

(Top View)

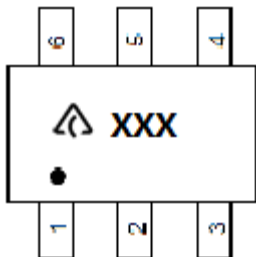

 : Logo
 XXX: Marking ID (See Ordering Information)

Package Outline Dimensions (All dimensions in mm(inch).)

(1) Package Type: SOT26

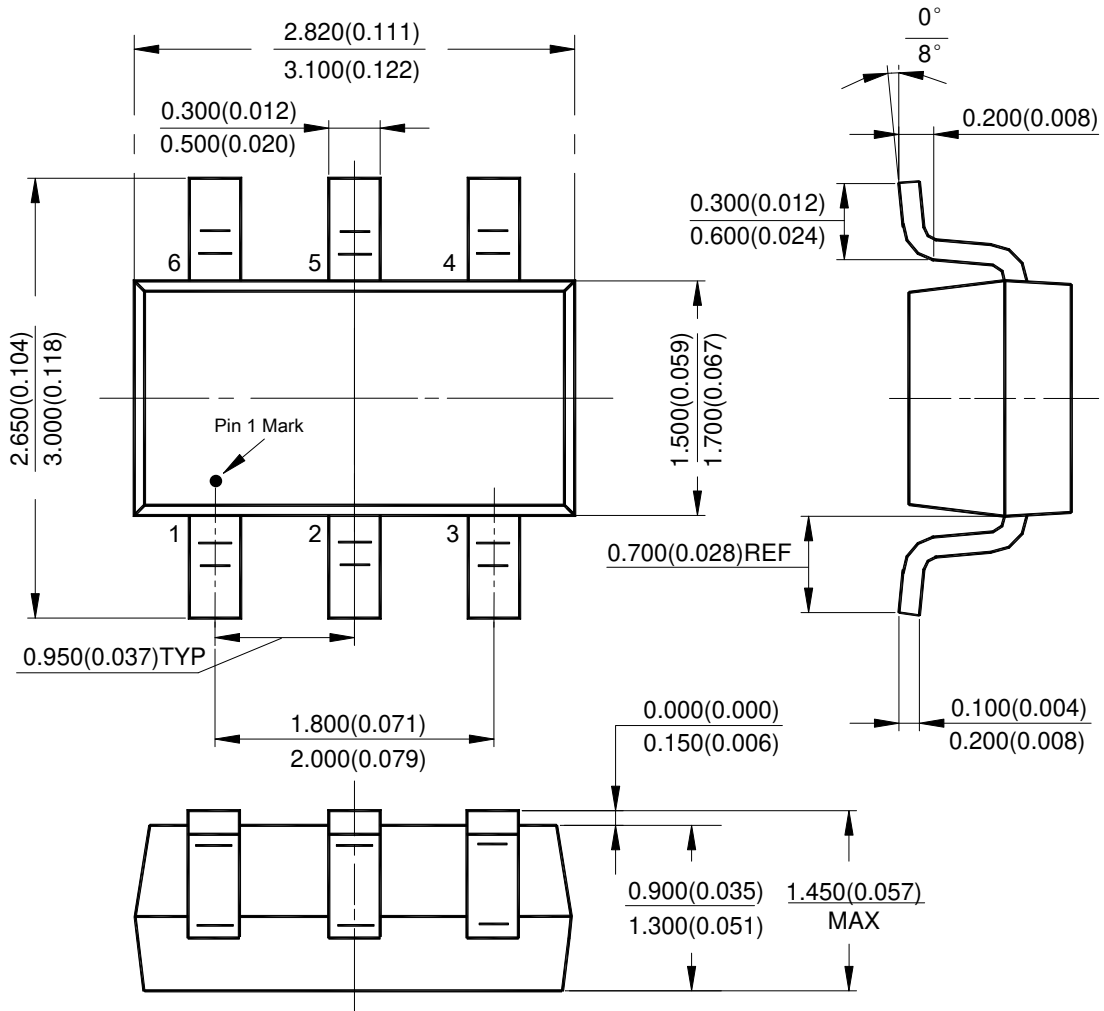

NEW PRODUCT

Suggested Pad Layout

(1) Package Type: SOT26

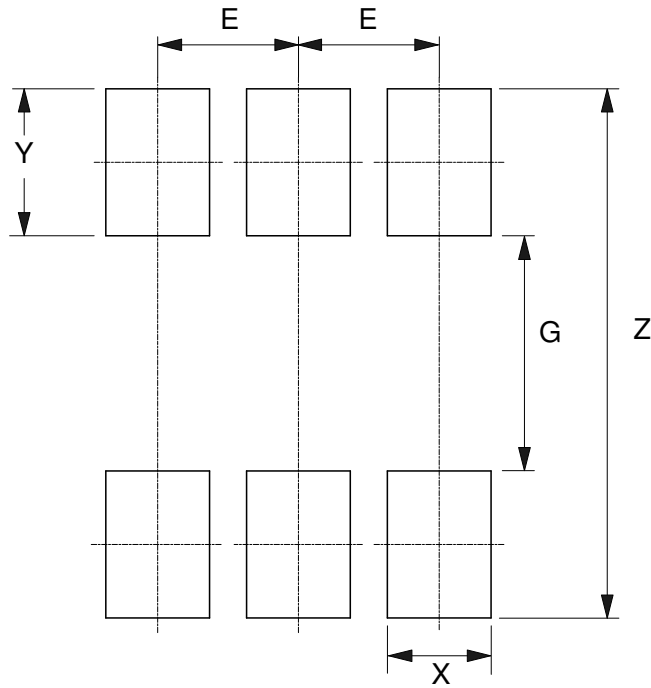

Dimensions	Z (mm)/(inch)	G (mm)/(inch)	X (mm)/(inch)	Y (mm)/(inch)	E (mm)/(inch)
Value	3.600/0.142	1.600/0.063	0.700/0.028	1.000/0.039	0.950/0.037

NEW PRODUCT

IMPORTANT NOTICE

DIODES INCORPORATED MAKES NO WARRANTY OF ANY KIND, EXPRESS OR IMPLIED, WITH REGARDS TO THIS DOCUMENT, INCLUDING, BUT NOT LIMITED TO, THE IMPLIED WARRANTIES OF MERCHANTABILITY AND FITNESS FOR A PARTICULAR PURPOSE (AND THEIR EQUIVALENTS UNDER THE LAWS OF ANY JURISDICTION).

Diodes Incorporated and its subsidiaries reserve the right to make modifications, enhancements, improvements, corrections or other changes without further notice to this document and any product described herein. Diodes Incorporated does not assume any liability arising out of the application or use of this document or any product described herein; neither does Diodes Incorporated convey any license under its patent or trademark rights, nor the rights of others. Any Customer or user of this document or products described herein in such applications shall assume all risks of such use and will agree to hold Diodes Incorporated and all the companies whose products are represented on Diodes Incorporated website, harmless against all damages.

Diodes Incorporated does not warrant or accept any liability whatsoever in respect of any products purchased through unauthorized sales channel. Should Customers purchase or use Diodes Incorporated products for any unintended or unauthorized application, Customers shall indemnify and hold Diodes Incorporated and its representatives harmless against all claims, damages, expenses, and attorney fees arising out of, directly or indirectly, any claim of personal injury or death associated with such unintended or unauthorized application.

Products described herein may be covered by one or more United States, international or foreign patents pending. Product names and markings noted herein may also be covered by one or more United States, international or foreign trademarks.

This document is written in English but may be translated into multiple languages for reference. Only the English version of this document is the final and determinative format released by Diodes Incorporated.

LIFE SUPPORT

Diodes Incorporated products are specifically not authorized for use as critical components in life support devices or systems without the express written approval of the Chief Executive Officer of Diodes Incorporated. As used herein:

A. Life support devices or systems are devices or systems which:

1. are intended to implant into the body, or
2. support or sustain life and whose failure to perform when properly used in accordance with instructions for use provided in the labeling can be reasonably expected to result in significant injury to the user.

B. A critical component is any component in a life support device or system whose failure to perform can be reasonably expected to cause the failure of the life support device or to affect its safety or effectiveness.

Customers represent that they have all necessary expertise in the safety and regulatory ramifications of their life support devices or systems, and acknowledge and agree that they are solely responsible for all legal, regulatory and safety-related requirements concerning their products and any use of Diodes Incorporated products in such safety-critical, life support devices or systems, notwithstanding any devices- or systems-related information or support that may be provided by Diodes Incorporated. Further, Customers must fully indemnify Diodes Incorporated and its representatives against any damages arising out of the use of Diodes Incorporated products in such safety-critical, life support devices or systems.

Copyright © 2015, Diodes Incorporated

www.diodes.com