

DESCRIPTION: FEMALE - 0.370 RIGHT ANGLE / MACHINED - ECONOMY

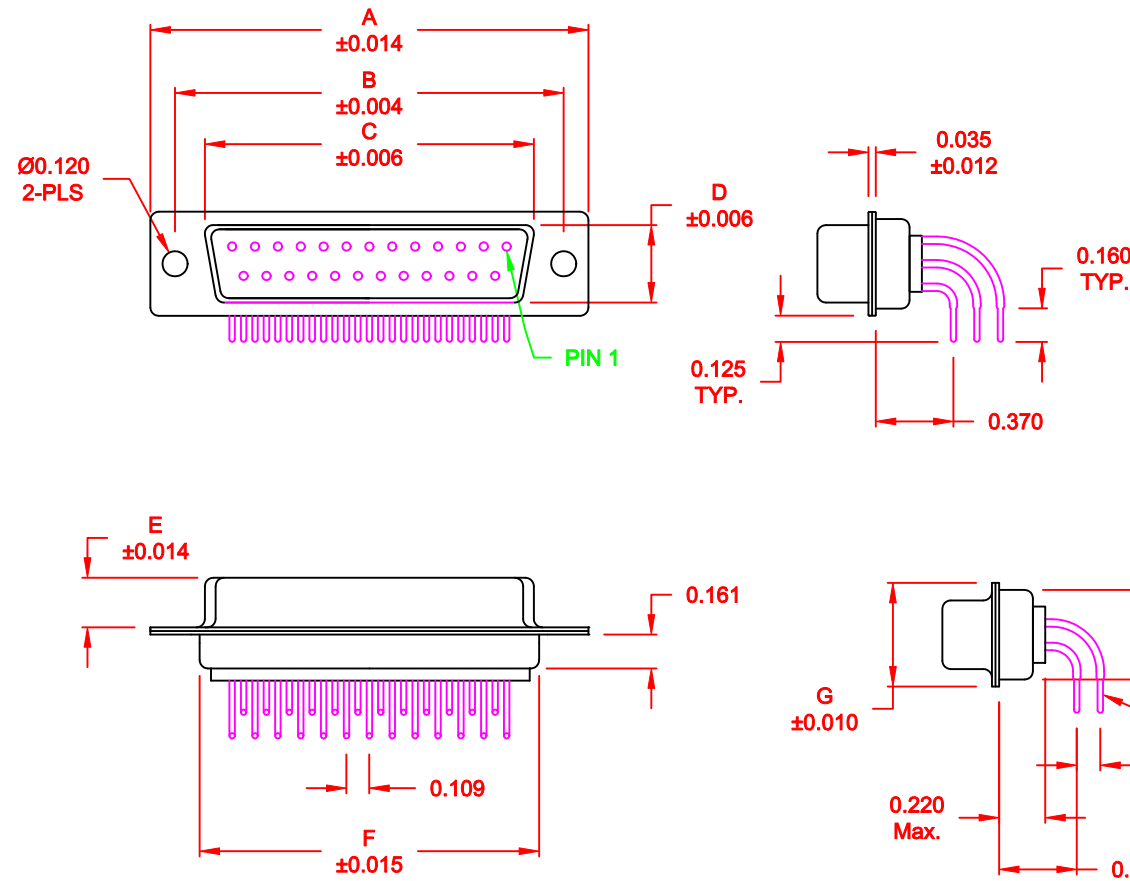

No. OF PINS	DIMENSIONS							
	A	B	C	D	E	F	G	H
9	1.213	0.984	0.642	0.311	0.236	0.756	0.496	0.427
	30.80	24.99	16.30	7.90	5.99	19.20	12.60	10.85
15	1.541	1.312	0.970	0.311	0.236	1.091	0.496	0.427
	39.15	33.32	24.65	7.90	5.99	27.70	12.60	10.85
25	2.087	1.852	1.512	0.311	0.236	1.618	0.496	0.427
	53.00	47.04	38.40	7.90	5.99	41.10	12.60	10.85
37	2.728	2.500	2.157	0.311	0.236	2.256	0.496	0.427
	69.30	63.50	54.80	7.90	5.99	57.30	12.60	10.85
50	2.638	2.406	2.055	0.429	0.240	2.169	0.602	0.527
	67.00	61.11	52.20	10.90	6.10	55.10	15.30	13.39

174-EYY-211RYY1

- SERIES \_\_\_\_\_
- POSITIONS \_\_\_\_\_
- E09 \_\_\_\_\_
- E15 \_\_\_\_\_
- E25 \_\_\_\_\_
- E37 \_\_\_\_\_
- E50 \_\_\_\_\_
- GENDER \_\_\_\_\_
- 2 = FEMALE
- TERMINATION \_\_\_\_\_
- 1 = PC MOUNTING
- SHELL PLATING \_\_\_\_\_
- 1 = YELLOW CHROMATE (NON-ROHS)
- HARDWARE OPTIONS \_\_\_\_\_
- 00 = NO HARDWARE
- 14 = SHORT BRACKET WITH 4-40 SCREW LOCK
- 24 = SHORT BRACKET WITH 4-40 SCREW
- PLATING OPTIONS \_\_\_\_\_
- 1 = GOLD FLASH
- 2 = 30MICRO-INCH GOLD

**MATERIAL:**

SHELL: STEEL, YELLOW CHROMATE  
 INSULATOR: UL 94V-O RATED, WHITE PA6T  
 PROCESS TEMP.: 260° PROCESS TEMPERATURE  
 CONTACT: BRASS

**ELECTRICAL:**

CURRENT RATING: 5 AMPS  
 CONTACT RESISTANCE: 15 mOhms Max.  
 INSULATION RESISTANCE: 1,000 MOhms min.  
 VOLTAGE: 500VAC FOR 1 MINUTE  
 TEMPERATURE: -50° C TO 100° C

DO NOT SCALE FROM DRAWING

	THESE DRAWINGS AND SPECIFICATIONS ARE THE PROPERTY OF NorComp AND SHALL NOT BE REPRODUCED, COPIED OR USED AS THE BASIS FOR THE MANUFACTURE OF SALE OF APPARATUS WITHOUT WRITTEN PERMISSION.		DRAWN: <b>WAYNE ROBBINS</b>	DATE: <b>11-28-05</b>
			CHECKED:	DATE:
<b>NorComp</b>	SCALE: <b>1:1</b>	SHEET <b>1</b> OF <b>3</b>	REV <b>1</b>	
	DWG NO. <b>174-EYY-211RYY1</b>			

DESCRIPTION: PCB LAYOUT - MALE & FEMALE

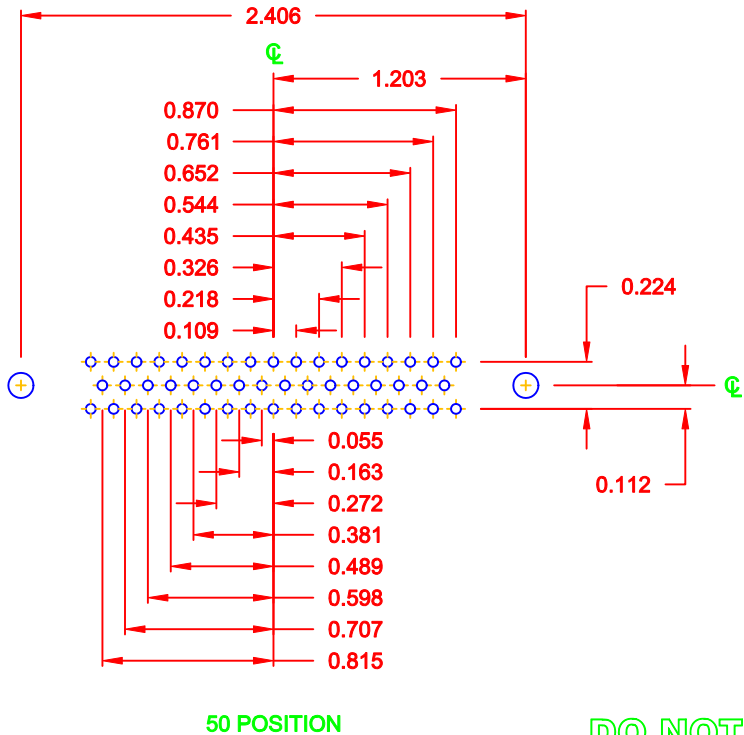
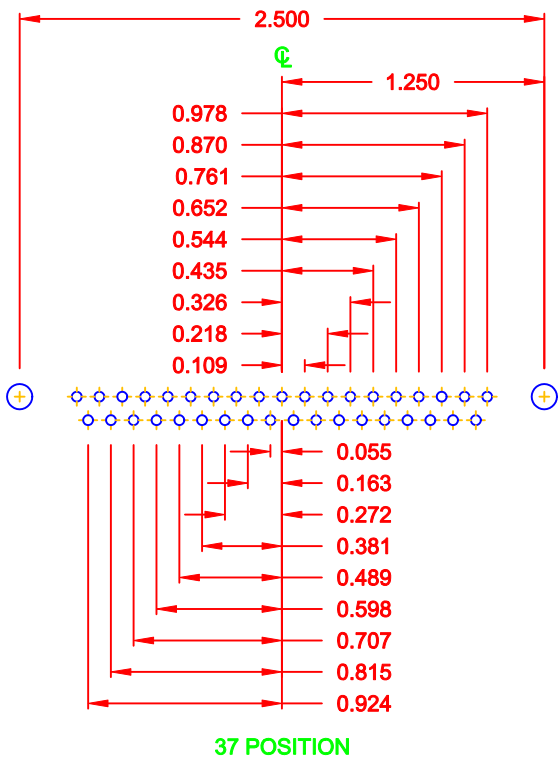
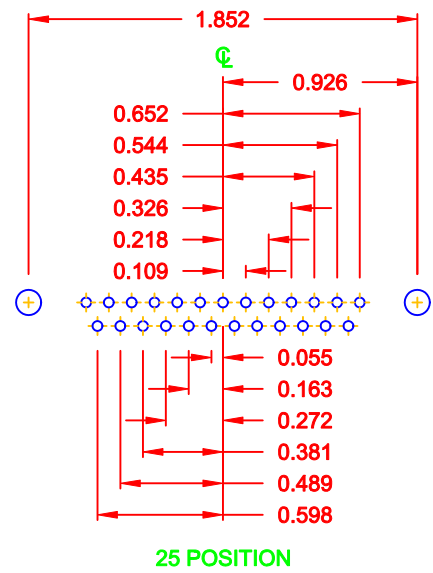
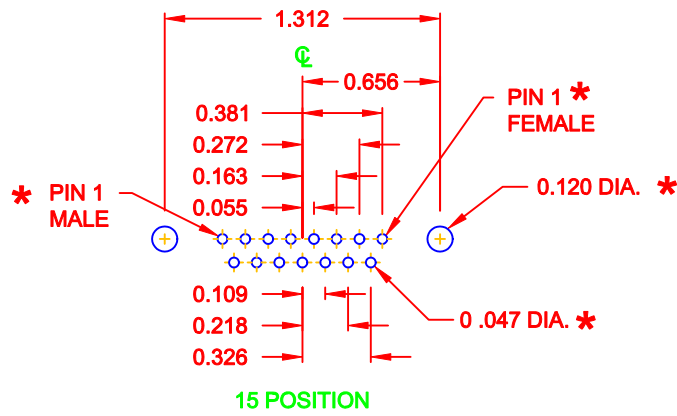
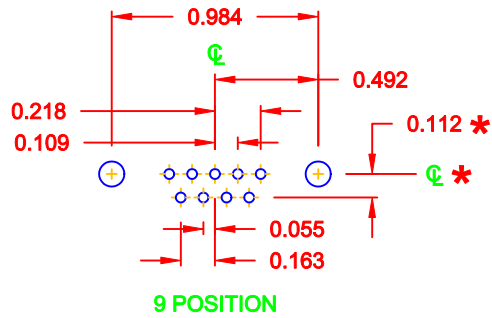

\* TYP. ON ALL SIZES  
UNLESS NOTED OTHERWISE

DO NOT SCALE FROM DRAWING

	THESE DRAWINGS AND SPECIFICATIONS ARE THE PROPERTY OF NorComp AND SHALL NOT BE REPRODUCED, COPIED OR USED AS THE BASIS FOR THE MANUFACTURE OF SALE OF APPARATUS WITHOUT WRITTEN PERMISSION.		DRAWN: <b>C. SMITH</b>	DATE: <b>03-08-06</b>
			CHECKED:	DATE:
<b>NorComp</b>		SCALE: <b>FULL</b>	SHEET <b>2</b> OF <b>3</b>	REV <b>1</b>
		DWG NO. <b>174-EYY-211RYY1</b>		

DESCRIPTION: CLINCH NUT HARDWARE

**HARDWARE OPTIONS**

REPLACE -YY IN LAST 3 DIGITS WITH OPTION CHOSEN

173/174 SERIES

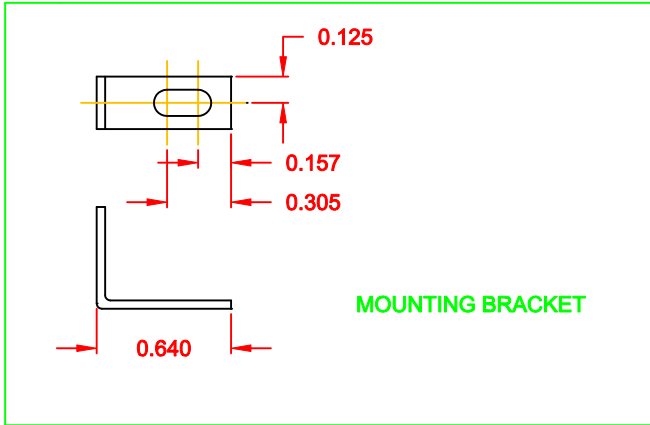

173 / 174 SERIES

- 14Y = SHORT BRACKET & 4-40 FEMALE HEX SOCKET
- 24Y = SHORT BRACKET & 4-40 SCREW

175/176 SERIES

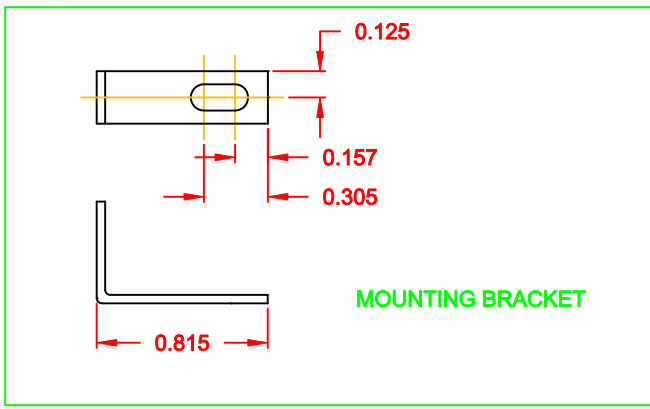

175 / 176 SERIES

- 15Y = LONG BRACKET & 4-40 FEMALE HEX SOCKET
- 25Y = SHORT BRACKET & 4-40 SCREW

MATERIAL: COLD ROLLED STEEL  
 PLATING: CLEAR ZINC

DO NOT SCALE FROM DRAWING

	THESE DRAWINGS AND SPECIFICATIONS ARE THE PROPERTY OF NorComp AND SHALL NOT BE REPRODUCED, COPIED OR USED AS THE BASIS FOR THE MANUFACTURE OF SALE OF APPARATUS WITHOUT WRITTEN PERMISSION.		DRAWN: <b>PAM JENKINS</b>	DATE: <b>11-28-05</b>
			CHECKED:	DATE:
<b>NorComp</b>		SCALE: <b>1 : 1</b>	SHEET <b>3</b> OF <b>3</b>	REV <b>1</b>
		DWG NO. <b>174-EYY-211RYY1</b>		