

Bestückungsplan - contact layout

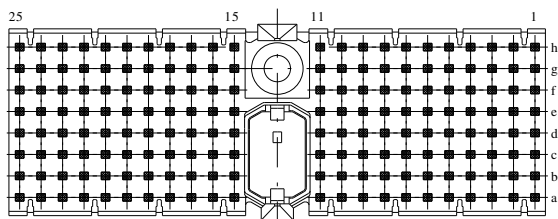

■ = bestückt - assemble

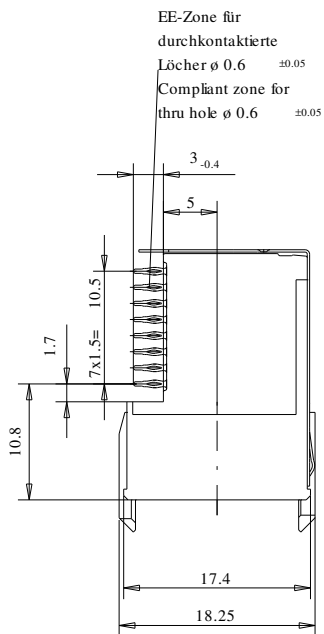
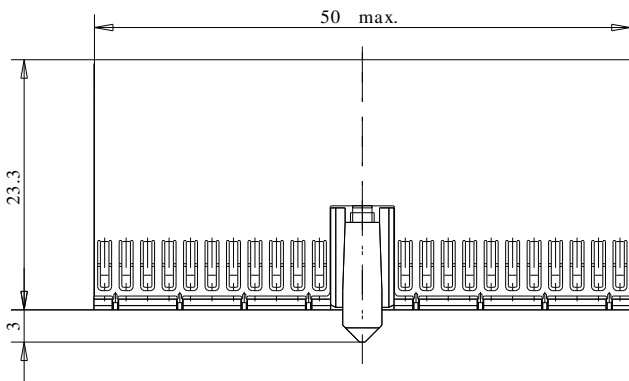
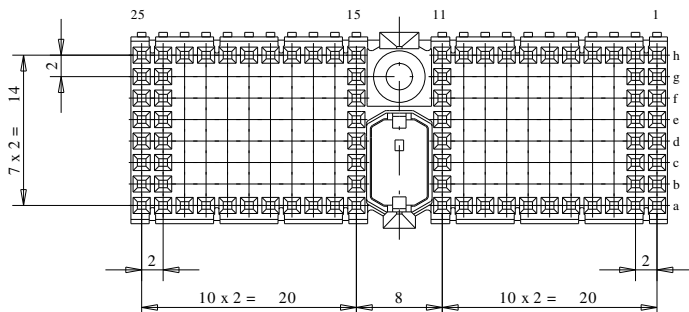

EE-Zone für durchkontaktierte Löcher $\phi 0.6 \pm 0.05$
Compliant zone for thru hole $\phi 0.6 \pm 0.05$

Lochbild für Leiterplatte (Bestückungsseite)

Board hole pattern (Component mounting side)

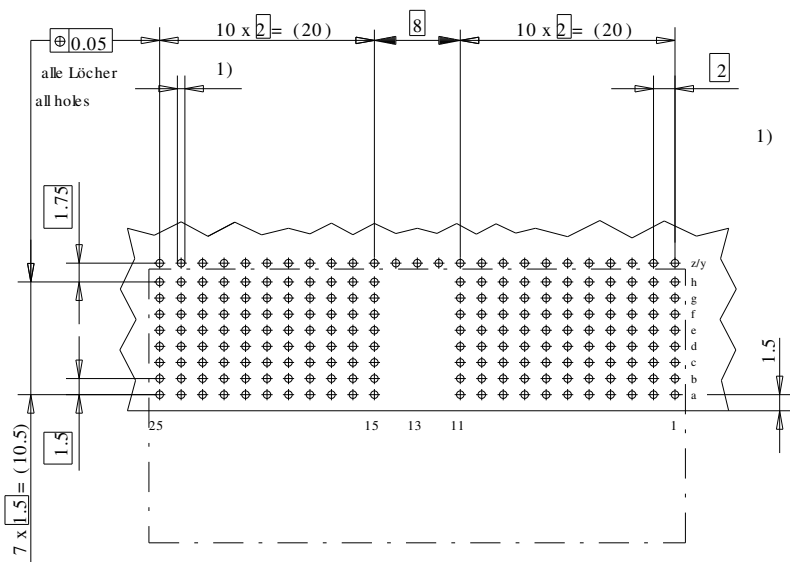

- 1) $\phi 0.6 \pm 0.05$ Durchmesser des metallisierten Loches
 $\phi 0.6 \pm 0.05$ Diameter of finished plated-through hole
- $\phi 0.7 \pm 0.02$ Bohrungsdurchmesser des Loches
 $\phi 0.7 \pm 0.02$ Diameter of drilled hole

Schichtaufbau im metallisierten Loch siehe Zeichnung 144406

Metal plating of plated-through hole see drawing 144406

Fehlende Masse und Angaben nach IEC 61076-4-101
Missing information and dimensions per IEC 61076-4-101

Information: ohne Fixierstift - without locating pegs Abschirmblech oben montiert shielding mounted on top	Tolerances All Dimensions in mm	Scale 2:1
		Angaben zu entsprechender Ident-Nr. siehe Fertigungsunterlagen For further information about LD. number see manufacturing document
All rights reserved. Only for information. To insure that this is the latest version of this drawing, please contact one of the ERNI companies before using.	Subject to modification without prior notice. Drawing will not be updated.	Designation ERmet Federleiste D ERmet Female Type D
		104935
a Index	06.03.200 Date	ERNI www.ERNI.com
M:00018516.SZA		ERM D

Bedruckung siehe Zeichnung 401194
Marking see drawing 401194

Consider protection memo from DFN 34