

MX150 16 WAY HYBRID RCPTACLE SEALED CONNECTOR - STANDARD (STD)

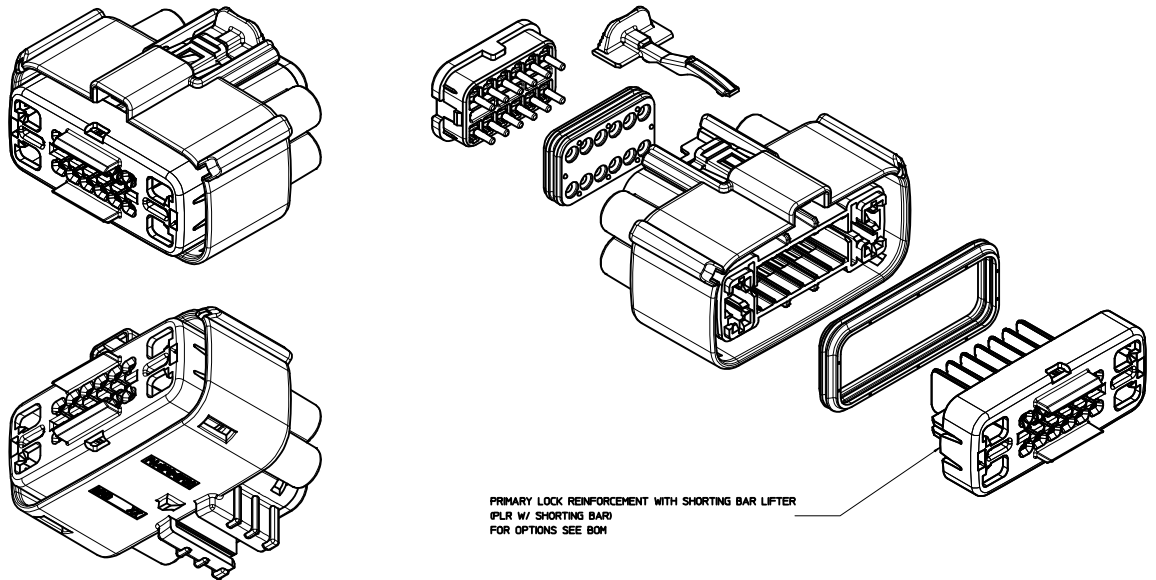

MX150 16 WAY HYBRID RCPTACLE SEALED CONNECTOR - SHORTING (SHRT) BAR
UNLESS COMPONENT NOTED, SEE STANDARD ASSEMBLY

TABLE OF CONTENTS	
SHEET NO.	SHEET DESCRIPTION
1	NOTES
2	KEY CONFIGURATIONS
3	RECEPTACLE SEALED ASSEMBLY
4-6	BOM

NOTES: VALID UNLESS OTHERWISE SPECIFIED

1. GENERAL:

- a. APPLICATION SPECIFICATION SEE: AS-33472-100
 - CONTAINS: PRODUCT INTRODUCTION, PRODUCT SUMMARY, CONNECTOR ASSEMBLY, PACKAGING INFORMATION, CONNECTOR MATING, SERVICE INSTRUCTIONS, ELECTRICAL CONTINUITY CHECKING, CRIMPING, AND TROUBLESHOOTING.
 - STANDARD (NON-SHRT) CONFIGURATIONS DESIGNED TO MATE WITH DEVICE CONNECTION AS SPECIFIED IN DRAWING EWCAP 999-5-016-2-202. AVAILABLE AT <http://www.cpacar.com>
 - STANDARD (NON-SHRT) CONFIGURATIONS AND SHORTING BAR CONFIGURATIONS DESIGNED TO MATE WITH BLADE HOUSING ASSEMBLY SPECIFIED IN DRAWING SD-33486-161.
 - FOR 1.5mm RECEPTACLE TERMINALS TO BE USED WITH THIS ASSEMBLY. SEE MOLEX DRAWING SD-33092-002.
 - FOR 2.8mm RECEPTACLE TERMINALS TO BE USED WITH THIS ASSEMBLY SEE TABLE.
 - 2.8mm TERMINALS TO BE USED WITH WIRE WITHIN DIAMETER RANGE OF 150mm TO 3.30mm.
 - ASSEMBLY SHIPPED WITH PLR AND CPA IN PRE-LOCK POSITION (SEE SECTION Z-Z PRE-LOCK).
 - IN THE EVENT THAT THE PLR IS FOUND IN THE SEATED (FINAL LOCK) POSITION, REFER TO MOLEX SPECIFICATION PS-34666-001. AVAILABLE AT www.molex.com -<http://www.molex.com>
 - ASSEMBLY CONFORMS TO SAE/USCAR-2 REV.4 WITH THE FOLLOWING EXCEPTIONS: ENGAGEMENT FORCE TO MOVE CPA FROM PRE-LOCK TO FINAL LOCK POSITION WHEN UNMATED: 40N MN.
 - DISENGAGEMENT FORCE TO MOVE CPA FROM FINAL LOCK TO PRE-LOCK POSITION: 3N MIN 40N MAX.
 - TERMINAL INSERTION FORCE FOR WIRE DIAMETER ABOVE 2.5mm NOT EXCEEDING 2.69mm SHALL NOT EXCEED 40 NEWTONS.

b. PRODUCT SPECIFICATION SEE: PS-33476-000

- CONTAINS: PRODUCT INTRODUCTION, PRODUCT SUMMARY, RATINGS (CURRENT, TEMPERATURE, SEALING, AND FLAMMABILITY), AND PRODUCT VALIDATION.

c. PACKAGING SPECIFICATION PER MOLEX DRAWING: PK-30907-895

d. PARTS MUST BE IN COMPLIANCE TO MOLEX CHEMICAL SUBSTANCES FOR PRODUCTS SPECIFICATIONS ES-40000-5016

e. DATA MUST BE SUBMITTED UNDER THE MOLEX PART NUMBER TO MDS (COMPANY 049295)

f. FOR INFORMATION ON 16 WAY HYBRID RECEPT HRN ASSY WITHOUT CLIPSLOT SEE E-33476-161

2. DESIGN - MATERIALS:

a. SEE BOM TABLE

3. DESIGN - GEOMETRY:

- a. THIS IS A 100% CAD GENERATED PART. THE CAD MATHEMATICAL DATA IS THE MASTER FOR THIS PART. FOR DIMENSIONAL OR ANY INFORMATION NOT SHOWN ON THIS DRAWING, ANALYZE THE CAD MODEL.
- b. GEOMETRIC DIMENSIONS AND TOLERANCES PER ASME Y14.5M - 1994
- c. EDGES AND UNDIMENSIONED DETAILS PER ISO1975
- d. CORNERS SHOWN AS SHARP TO BE R 0.2 MAX.
- e. LETTERING SHALL BE 0.15 MAX RAISED IN 0.25 MAX RECESS PAD. THIS INCLUDES RECYCLING CODE, CAVITY ID, VENDOR IDENTIFICATION, AND CUSTOMER MATERIAL NUMBER.
- f. VISUAL DEFECTS SHALL MEET COSMETIC STANDARD PS-45499-002 (Class B)
- g. LASER MARKING: TBD

TYCO 2.8mm CABLE SEAL TERMINAL		
FORD P/N FEMALE RECEPTACLE	GRIP SIZE	
IFIT-14474-KA	12	
IFIT-14474-JA	14	
IFIT-14474-HA	16	
IFIT-14474-GA	18	
IFIT-14474-FA	20	
IFIT-14474-EA	22	

INSPECTION NUMBER LOG
LAST NUMBER USED:
ADDED:
REMOVED:

REV	DESCRIPTION
BC	UPDATED TO PLANNED OBSOLESCENCE
BB	ADD NEW P/N 33476-2345 THRU 33476-2348
BA10	ADD NEW P/N 33476-2343 THRU 33476-2344
BA9	ADD NEW P/N 33476-2338 THRU 33476-2342
BA8	CHANGE TO PK-30907-895
BA7	ADD NEW P/N 33476-2336 THRU 33476-2337
BA6	ADD NEW P/N 33476-2333 THRU 33476-2335
BA5	ADD NEW P/N 33476-2332
BA4	ADD NEW P/N 33476-2327 THRU 2331
BA3	ADD NEW P/N 33476-2314 THRU 2326
BA2	ADD NEW P/N 33476-2313
BA1	ADD NEW P/N 33476-2312
BA	ADD NEW P/N 33476-2310 33476-2311
A210	ADD NEW P/N 33476-2308 33476-2309
A29	ADD NEW P/N 33476-2305 33476-2306 33476-2307
A28	ADD NEW P/N 33476-2304
A27	ADD NEW P/N 33476-2303
A26	ADD NEW P/N 33476-2301 33476-2302
A25	ADD NEW P/N 33476-2295 33476-2300
A24	ADD NEW P/N 33476-2294
A23	ADD NEW P/N 33476-2292 33476-2293
	ADD NEW P/N 33476-2285 33476-2286 33476-2287 33476-2288 33476-2289 33476-2290
A22	33476-2291
A21	ADD NEW P/N 33476-2283 33476-2284
A2	ADD NEW P/N 33476-2279 33476-2280
AY17	ADD NEW P/N 33476-2278
AY16	ADD NEW P/N 33476-2275 33476-2276 33476-2277
AY15	ADD NEW P/N 33476-2273 33476-2274
AY14	ADD NEW P/N 33476-2265 33476-2266 33476-2267 33476-2268 33476-2269 33476-2270 33476-2271 33476-2272
AY13	ADD NEW P/N 33476-2263 33476-2264
AY12	ADD NEW P/N 33476-2262
AY11	ADD NEW P/N 33476-2261
AY10	ADD NEW P/N 33476-2260
AY9	ADD NEW P/N 33476-2257 33476-2258 33476-2259
AY8	UPDATED 2.8MM WIRE SIZE
AY7	UPDATED WIRE SIZE
AY6	ADD NEW P/N 33476-2255 33476-2256
AY5	ADD NEW P/N 33476-2254
AY4	ADD NEW P/N 33476-2253

ENTER DESCRIPTION EC NO: JAU0206-0550 10/17/14 DRAWN BY: JAU0206-0550 10/17/14 CHECKED BY: JAU0206-0550 10/17/14 APPROVED BY: JAU0206-0550 10/17/14 REV:	QUALITY SYMBOLS ∇=0 ∇=0 ∇=0	GENERAL TOLERANCES (UNLESS SPECIFIED) mm INCH 4 PLACES ± --- ± --- 3 PLACES ± --- ± --- 2 PLACES ± 0.10 ± --- 1 PLACE ± 0.3 ± --- 0 PLACE ±	DIMENSION STYLE MM ONLY DRAWN BY DATE KUNNINGHAM 2011/10/26 CHECKED BY DATE APPROVED BY DATE	SCALE 3:1 DESIGN UNITS METRIC THIRD ANGLE PROJECTION	TITLE MX150 16 WAY HYBRID RCPT SEALED ASSEMBLY CLIPSLOT molex	SHEET NO. OF 7	
	DRAFT WHERE APPLICABLE MUST REMAIN WITHIN DIMENSIONS		MATERIAL NO. SEE BOM	DOCUMENT NO. SD-33476-181	THIS DRAWING CONTAINS INFORMATION THAT IS PROPRIETARY TO MOLEX. INCORPORATED AND SHOULD NOT BE USED WITHOUT WRITTEN PERMISSION		
			ANGULAR ± 3 °				
			SIZE E				

KEY CONFIGURATIONS

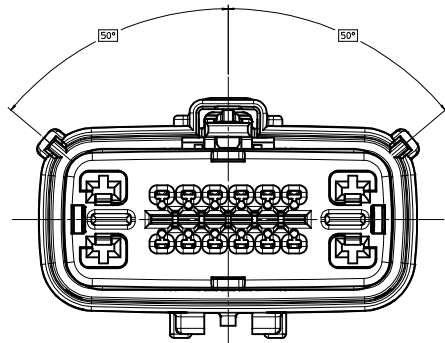

KEY A

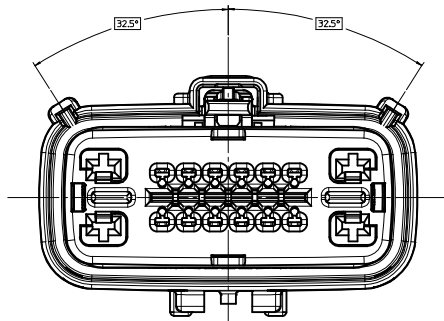

KEY E

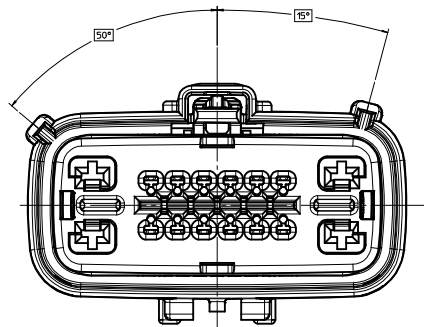

KEY B

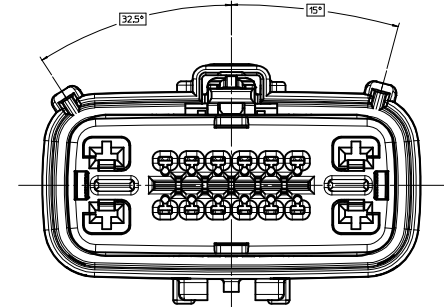

KEY F

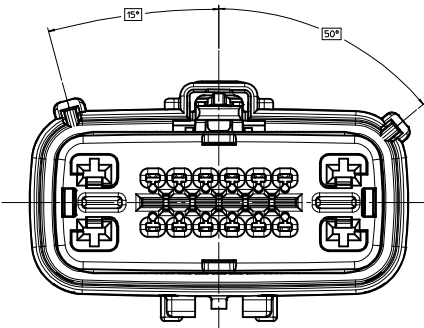

KEY C

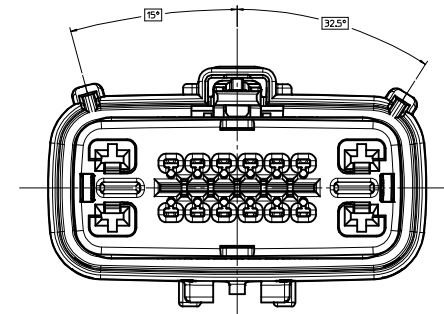

KEY G

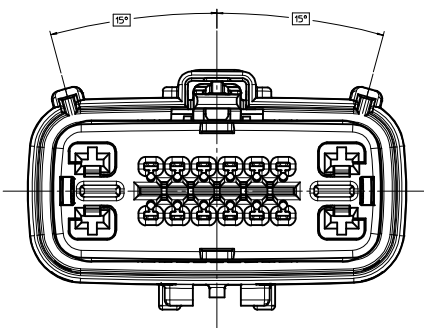

KEY D

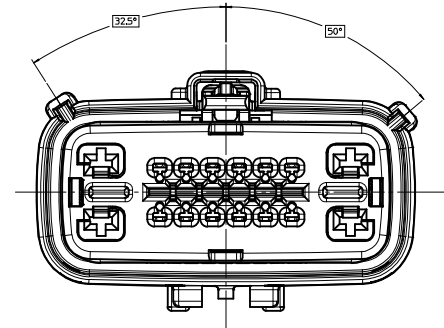

KEY H

ENTER DESCRIPTION EC NO. 040206-0550 DRAWN BY: JACOB CHECKED BY: JACOB APPROVED BY: JACOB DATE: 2015/10/28	QUALITY SYMBOLS ∇=0 ∇=0 ∇=0	GENERAL TOLERANCES (UNLESS SPECIFIED) <table border="1"> <thead> <tr> <th></th> <th>mm</th> <th>INCH</th> </tr> </thead> <tbody> <tr> <td>4 PLACES</td> <td>± .10</td> <td>± .004</td> </tr> <tr> <td>3 PLACES</td> <td>± .15</td> <td>± .006</td> </tr> <tr> <td>2 PLACES</td> <td>± 0.10</td> <td>± .004</td> </tr> <tr> <td>1 PLACE</td> <td>± 0.3</td> <td>± .012</td> </tr> <tr> <td>0 PLACE</td> <td>±</td> <td>±</td> </tr> </tbody> </table>		mm	INCH	4 PLACES	± .10	± .004	3 PLACES	± .15	± .006	2 PLACES	± 0.10	± .004	1 PLACE	± 0.3	± .012	0 PLACE	±	±	DIMENSION STYLE MM ONLY	SCALE 4:1	DESIGN UNITS METRIC	THIRD ANGLE PROJECTION
		mm	INCH																					
	4 PLACES	± .10	± .004																					
	3 PLACES	± .15	± .006																					
2 PLACES	± 0.10	± .004																						
1 PLACE	± 0.3	± .012																						
0 PLACE	±	±																						
			DRAWN BY: DATE KCUNNINGHAM 2011/10/26	TITLE MX150 16 WAY HYBRID RECEPT SEALED ASSEMBLY CLIPSLOT																				
			CHECKED BY: DATE APPROVED BY: DATE	MATERIAL NO. SEE BOM DOCUMENT NO. SD-33476-181																				
		ANGULAR ± 3 ° DRAFT WHERE APPLICABLE MUST REMAIN WITHIN DIMENSIONS	THIS DRAWING CONTAINS INFORMATION THAT IS PROPRIETARY TO MOLEX INCORPORATED AND SHOULD NOT BE USED WITHOUT WRITTEN PERMISSION																					

RECEPTACLE SEALED ASSEMBLY

OPTIONAL LASER MARKING ON THIS SURFACE
SEE NOTE 3g.

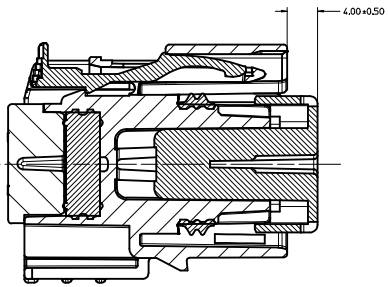
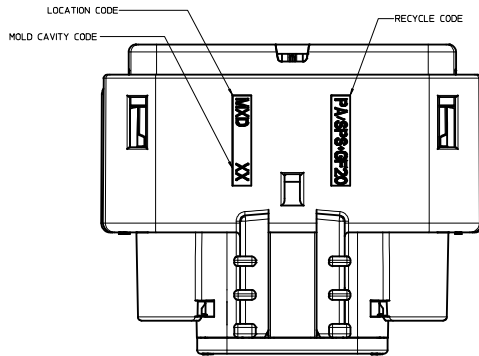
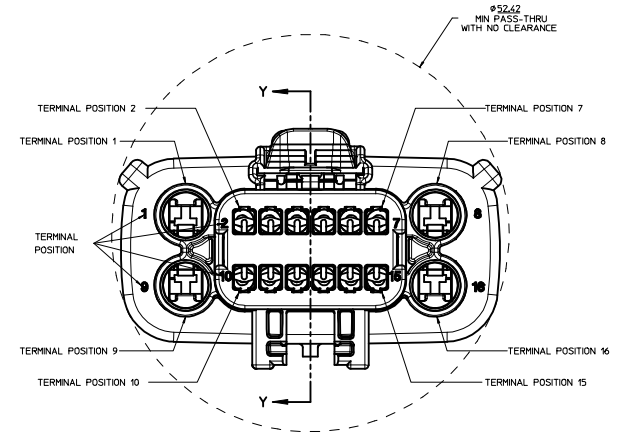
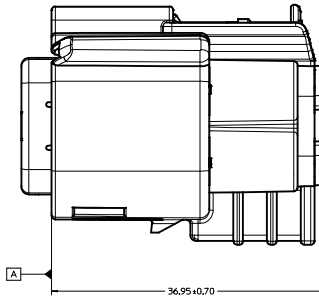
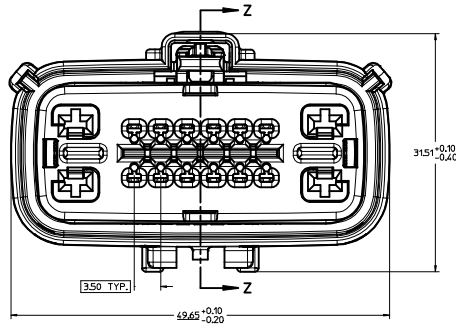
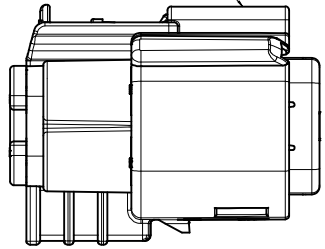

PRIMARY LOCK REINFORCEMENT (PLR) SHOWN
IN PRE-STAGED POSITION
SECTION Z-Z

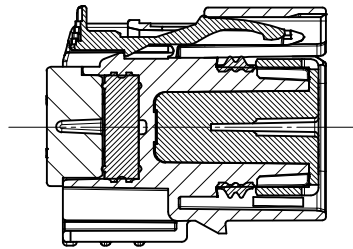

PRIMARY LOCK REINFORCEMENT (PLR) SHOWN
IN FINAL-LOCK POSITION
SECTION Y-Y

ENTER DESCRIPTION EC NO. UAU2016-0550 DRAWN BY: J. W. BETHUNE CHECKED BY: J. W. BETHUNE APPR. MOSES, 2015/10/28	QUALITY SYMBOLS ∇=0 ∇=1 ∇=2	GENERAL TOLERANCES (UNLESS SPECIFIED) <table border="1"> <thead> <tr> <th></th> <th>mm</th> <th>INCH</th> </tr> </thead> <tbody> <tr> <td>4 PLACES</td> <td>± .10</td> <td>± .004</td> </tr> <tr> <td>3 PLACES</td> <td>± .15</td> <td>± .006</td> </tr> <tr> <td>2 PLACES</td> <td>± 0.10</td> <td>± .004</td> </tr> <tr> <td>1 PLACE</td> <td>± 0.3</td> <td>± .012</td> </tr> <tr> <td>0 PLACE</td> <td>±</td> <td>±</td> </tr> </tbody> </table>		mm	INCH	4 PLACES	± .10	± .004	3 PLACES	± .15	± .006	2 PLACES	± 0.10	± .004	1 PLACE	± 0.3	± .012	0 PLACE	±	±	DIMENSION STYLE MM ONLY	SCALE 4:1	DESIGN UNITS METRIC	THIRD ANGLE PROJECTION
		mm	INCH																					
	4 PLACES	± .10	± .004																					
	3 PLACES	± .15	± .006																					
2 PLACES	± 0.10	± .004																						
1 PLACE	± 0.3	± .012																						
0 PLACE	±	±																						
DRAWN BY: DATE X. CUNNINGHAM 2011/10/26	CHECKED BY: DATE	APPROVED BY: DATE	MATERIAL NO. SEE BOM	DOCUMENT NO. SD-33476-181	SHEET NO. 3 OF 7																			
DRAFT WHERE APPLICABLE MUST REMAIN WITHIN DIMENSIONS	SIZE E	THIS DRAWING CONTAINS INFORMATION THAT IS PROPRIETARY TO MOLEX INCORPORATED AND SHOULD NOT BE USED WITHOUT WRITTEN PERMISSION																						
BC																								

KEY	DESCRIPTION	QTY	UNIT	P	2	3	4	5	6	7	10	11	12	13	14	15	16
KEY A, BLACK	33476-2253	A													11		14
KEY A, BLACK	33476-2252	A													11		14
KEY A, BLACK	33476-2251	A						2	3	4	5						
KEY A, BLACK	33476-2250	A													5	6	7
KEY A, BLACK	33476-2249	A													5	6	7
KEY A, BLACK	33476-2248	A													5	6	7
KEY A, BLACK	33476-2247	A													2	3	4
KEY A, BLACK	33476-2246	A													7		11
KEY A, BLACK	33476-2245	A													7		11
KEY A, BLACK	33476-2244	A													6	7	10
KEY A, BLACK	33476-2243	A													5	6	10
KEY A, BLACK	33476-2242	A													5		10
KEY A, BLACK	33476-2241	A													2		12
KEY A, BLACK	33476-2240	A													2	3	5
KEY A, BLACK	33476-2239	A													2	3	5
KEY A, BLACK	33476-2238	A													2	3	5
KEY A, BLACK	33476-2237	A													2	3	5
KEY A, BLACK	33476-2236	A													3	4	7
KEY A, BLACK	33476-2235	A													3	4	7
KEY A, BLACK	33476-2234	A													3	4	7
KEY A, BLACK	33476-2233	A													2	3	5
KEY A, BLACK	33476-2232	A													2	3	5
KEY A, BLACK	33476-2231	A													2	3	5
KEY A, BLACK	33476-2230	A													2	3	5
KEY A, BLACK	33476-2229	A													2		7
KEY A, BLACK	33476-2228	A													3		5
KEY A, BLACK	33476-2227	A													3		5
KEY A, BLACK	33476-2226	A													3		5
KEY A, BLACK	33476-2225	A													3		5
KEY A, BLACK	33476-2224	A													2		3
KEY A, BLACK	33476-2223	A													2	3	5
KEY A, BLACK	33476-2222	A													2	3	5
KEY A, BLACK	33476-2221	A													2	3	5
KEY A, BLACK	33476-2220	A													3		5
KEY A, BLACK	33476-2219	A													3		5
KEY A, BLACK	33476-2218	A													2	3	5
KEY A, BLACK	33476-2217	A													2	3	5
KEY A, BLACK	33476-2216	A													3	4	7
KEY F W/ SHRT, BAR, LT, GRAY	33476-2215	F													2	3	4
KEY A, BLACK	33476-2214	A													2	3	4
KEY A, BLACK	33476-2213	A													3	4	7
KEY A, BLACK	33476-2212	A													3	4	7
KEY F W/ SHRT, BAR, LT, GRAY	33476-2211	F													2	3	4
KEY F W/ SHRT, BAR, LT, GRAY	33476-2210	F													2	3	4
KEY F W/ SHRT, BAR, LT, GRAY	33476-2209	F													2	3	4
KEY F W/ SHRT, BAR, LT, GRAY	33476-2208	F													2	3	4
KEY F W/ SHRT, BAR, LT, GRAY	33476-2207	F													2	3	4
KEY F W/ SHRT, BAR, LT, GRAY	33476-2206	F													2	3	4
KEY F W/ SHRT, BAR, LT, GRAY	33476-2205	F													2	3	4
KEY F W/ SHRT, BAR, LT, GRAY	33476-2204	F													2	3	4
KEY F W/ SHRT, BAR, LT, GRAY	33476-2203	F													2	3	4
KEY F W/ SHRT, BAR, LT, GRAY	33476-2202	F													2	3	4
KEY E W/ SHRT, BAR, BLACK	33476-2201	E													2	3	4
KEY B, LT, GRAY	33476-2141	B													2	3	4
KEY A, BLACK	33476-2139	A													2	3	4
KEY A, BLACK	33476-2137	A													2	3	4
KEY F W/ SHRT, BAR, LT, GRAY	33476-2136	F													2	3	4
KEY F W/ SHRT, BAR, LT, GRAY	33476-2135	F													2	3	4
KEY F W/ SHRT, BAR, LT, GRAY	33476-2134	F													2	3	4
KEY A, YELLOW	33476-2133	A													2	3	4
KEY A, BLACK	33476-2130	A													2	3	4
KEY H W/ SHRT, BAR & CPA, YELLOW	33476-2129	H													2	3	4
KEY A, BLACK	33476-2128	A													2	3	4
KEY H W/ CPA, YELLOW	33476-2127	H													2	3	4
KEY A, BLACK	33476-2124	A													2	3	4
KEY A, BLACK	33476-2123	A													2	3	4
KEY A, BLACK	33476-2122	A													2	3	4
KEY A, BLACK	33476-2114	A													2	3	4
KEY A, BLACK	33476-2109	A													2	3	4
KEY A, BLACK	33476-2108	A													2	3	4
KEY A, BLACK	33476-2105	A													2	3	4
KEY B, LT, GRAY	33476-2104	B													2	3	4
KEY B, LT, GRAY	33476-2103	B													2	3	4
KEY B, LT, GRAY	33476-2072	B													2	3	4
KEY B, LT, GRAY	33476-2071	B													2	3	4
ASSEMBLY PART DESCRIPTION	ASSEMBLY PART NUMBER		A	B	C	D	E	F	G	H	I	J	K	L	M	N	O

PLANNED OBSOLESCENCE
SEE DRAWING SD-34985-8002
FOR REPLACEMENT P/NS
34985-XXXX

BLOCKED TERMINAL

CAVITY WITH A NUMBER INDICATES BLOCKED TERMINAL POSITION

CAVITY WITHOUT A NUMBER INDICATES OPEN TERMINAL POSITION

GROMMET CAP	BLACK	SPS/NYLON GF20
MAT SEAL	LIGHT BLUE	INHERENTLY LUBRICATED SILICONE
RING SEAL	GREEN	INHERENTLY LUBRICATED SILICONE
CPA	BRIGHT RED	PBT GF30
PLR SHRT, BAR LFFTER	NATURAL	PBT GF15
PLR STANDARD	NATURAL	SPS/NYLON GF20
HOUSING KEYING OPTION A	YELLOW	SPS/NYLON GF20
HOUSING KEYING OPTION H	YELLOW	SPS/NYLON GF20
HOUSING KEYING OPTION G	BROWN	SPS/NYLON GF20
HOUSING KEYING OPTION F	LIGHT GRAY	SPS/NYLON GF20
HOUSING KEYING OPTION E	BLACK	SPS/NYLON GF20
HOUSING KEYING OPTION D	GREEN	SPS/NYLON GF20
HOUSING KEYING OPTION C	BROWN	SPS/NYLON GF20
HOUSING KEYING OPTION B	LIGHT GRAY	SPS/NYLON GF20
HOUSING KEYING OPTION A	BLACK	SPS/NYLON GF20
DESCRIPTION	COLOR	MATERIAL

BOM/APPLICABLE COMPONENTS TABLE

LEGEND TABLE

ABBREVIATION	COMPONENT
A	HOUSING KEY A
B	HOUSING KEY B
C	HOUSING KEY C
D	HOUSING KEY D
E	HOUSING KEY E
F	HOUSING KEY F
G	HOUSING KEY G
H	HOUSING KEY H
GC	GROMMET CAP
M	MAT SEAL
P	PLR, STANDARD
PS	PLR, SHRT BAR LIFTER
R	RING SEAL
CPA	CPA

ENTER DESCRIPTION EC NO. UAU2016-0550 DRAWING NO. 2015/10/24 DATE 2015/10/24 APPR. W/ SIGNATURE 2015/10/24	QUALITY SYMBOLS ▽=0 ▽=1 ▽=2 ▽=3	GENERAL TOLERANCES (UNLESS SPECIFIED) <table border="1"> <tr><td></td><td>mm</td><td>INCH</td></tr> <tr><td>4 PLACES</td><td>±.010</td><td>±.0004</td></tr> <tr><td>3 PLACES</td><td>±.015</td><td>±.0005</td></tr> <tr><td>2 PLACES</td><td>±.030</td><td>±.0012</td></tr> <tr><td>1 PLACE</td><td>±.040</td><td>±.0015</td></tr> <tr><td>0 PLACE</td><td>±.075</td><td>±.0030</td></tr> </table> ANGULAR ± 3° DRAFT WHERE APPLICABLE MUST REMAIN WITHIN DIMENSIONS		mm	INCH	4 PLACES	±.010	±.0004	3 PLACES	±.015	±.0005	2 PLACES	±.030	±.0012	1 PLACE	±.040	±.0015	0 PLACE	±.075	±.0030	DIMENSION STYLE MM ONLY DRAWN BY DATE KCUNNINGHAM 2011/10/26 CHECKED BY DATE	SCALE DESIGN UNITS METRIC THIRD ANGLE PROJECTION	DOCUMENT NO. SD-33476-181 SHEET NO. 5 OF 7
		mm	INCH																				
4 PLACES	±.010	±.0004																					
3 PLACES	±.015	±.0005																					
2 PLACES	±.030	±.0012																					
1 PLACE	±.040	±.0015																					
0 PLACE	±.075	±.0030																					
APPROVED BY DATE MATERIAL NO. SEE BOM THIS DRAWING CONTAINS INFORMATION THAT IS PROPRIETARY TO MOLEX AND SHOULD NOT BE USED WITHOUT WRITTEN PERMISSION	TITLE MX150 16 WAY HYBRID RECEPT SEALED ASSEMBLY CLIPSLOT molex		INCORPORATED AND SHOULD NOT BE USED WITHOUT WRITTEN PERMISSION																				

ASSEMBLY DESCRIPTION	PART NUMBER	A	B	C	D	E	F	G	H	A	P	PS	CPA	2	3	4	5	6	7	10	11	12	13	14	15				
KEY A, BLACK	33476-2335										P											10	11	13	14				
KEY A, BLACK	33476-2334										P			2								10	11	13	14				
KEY A, BLACK	33476-2333										P			2		5	6					10	11	13	14				
KEY A, BLACK	33476-2332										P			2	3	4	5	6	7			10	11	13	14	15			
KEY H W/ SHIRT, BAR AND CPA, YELLOW	33476-2331									H	P		CPA	3								6	7		15				
KEY H W/ SHIRT, BAR AND CPA, YELLOW	33476-2330									H	P		CPA	2									10						
KEY B, W/ CPA, LT.GRAY	33476-2329	B									P		CPA																
KEY A, YELLOW	33476-2328										A	P																	
KEY A, W/ CPA, YELLOW	33476-2327										A	P		CPA															
KEY A, BLACK	33476-2326	A									P			2			5	6				10	11	14	15				
KEY A, BLACK	33476-2325	A									P											10	11	14	15				
KEY A, BLACK	33476-2324	A									P											10	11	14	15				
KEY A, BLACK	33476-2323	A									P											10	11						
KEY A, BLACK	33476-2322	A									P											10							
KEY B, LT.GRAY	33476-2321	B									P			2			5	6	7			11							
KEY B, LT.GRAY	33476-2320	B									P					4	5					10	11	12	13	14	15		
KEY A, BLACK	33476-2319	A									P			2	3							10	11	12					
KEY A, BLACK	33476-2318	A									P			2	3							7	10	11	12				
KEY A, BLACK	33476-2317	A									P			2	4							6		12	13				
KEY A, BLACK	33476-2316	A									P			2								6		12	13				
KEY A, BLACK	33476-2315	A									P			2	3	4	5					7							
KEY A, BLACK	33476-2314	A									P			2	3	4	5					6	7	10	11				
KEY A, BLACK	33476-2313	A									P					3	4	5				6	7	10	11				
KEY A, BLACK	33476-2312	A									P					3						6	7	11	12	13			
KEY H W/ SHIRT, BAR AND CPA, YELLOW	33476-2311									H		PS	CPA	2	3							6	7	10	11	12	13	14	15
KEY H W/ SHIRT, BAR AND CPA, YELLOW	33476-2310									H		PS	CPA	2	3							6	7	10	11	12	13	14	15
KEY A, BLACK	33476-2309										P			2												14			
KEY A, BLACK	33476-2308	A									P															7			
KEY F, LIGHT GRAY	33476-2307						F				PS			2	3							6	7	10		14	15		
KEY F, LIGHT GRAY	33476-2306						F				PS											6	7	10		14	15		
KEY A, BLACK	33476-2305	A									P					3						7	10	11	12	13	14	15	
KEY B, W/ CPA, LT. GRAY	33476-2304	B									P		CPA	2	3								11	12	13	14	15		
KEY B, W/ CPA, LT. GRAY	33476-2303	B									P		CPA	2	3								11	12	13	14	15		
KEY A, BLACK	33476-2302	A									P			3								6	7			15			
KEY A, BLACK	33476-2301	A									P			2	3	4	5	6				10	12	13		15			
KEY A, W/ CPA, YELLOW	33476-2300										A	P	CPA	2												14	15		
KEY A, W/ CPA, YELLOW	33476-2295										A	P	CPA	2	3											15			
KEY A, W/ CPA, YELLOW	33476-2294										A	P	CPA	2												12	13	14	15
KEY A, BLACK	33476-2293	A									P			3	4	5						10	11	12	13	14	15		
KEY A, BLACK	33476-2292	A									P			2	3							10	11	12	13	14	15		
KEY A, BLACK	33476-2291	A									P			3		5						10				15			
KEY A, BLACK	33476-2290	A									P			3	4	5	6					10	11	12	13	14	15		
KEY A, BLACK	33476-2289	A									P			2	3	4	5	6								15			
KEY A, BLACK	33476-2288	A									P											10	11	13		15			
KEY A, BLACK	33476-2287	A									P			2												15			
KEY A, BLACK	33476-2286	A									P						5	6	7			10	11			15			
KEY A, BLACK	33476-2285	A									P											6	7	10	11		15		
KEY A, BLACK	33476-2284	A									P			3								6	7	10	11		15		
KEY A, BLACK	33476-2283	A									P			3								6		11		15			
KEY A, BLACK	33476-2280	A									P			2			5	6	7			10	11			15			
KEY A, BLACK	33476-2279	A									P											10	11	12	13	14	15		
KEY A, BLACK	33476-2278	A									P												11	13	14	15			
KEY F, LIGHT GRAY	33476-2277						F				P											6	7	10	11	14	15		
KEY F, LIGHT GRAY	33476-2276						F				P											6	7	10	11	15			
KEY F, LIGHT GRAY	33476-2275						F				P											6	7	10	11	15			
KEY A, BLACK	33476-2274	A									P			2	3											14			
KEY A, BLACK	33476-2273	A									P			2	3														
KEY A, BLACK	33476-2272	A									P											7		11	12				
KEY A, BLACK	33476-2271	A									P											10	12	13					
KEY A, BLACK	33476-2270	A									P												7			15			
KEY A, BLACK	33476-2269	A									P												7		12	13	14	15	
KEY A, BLACK	33476-2268	A									P			3								7	10	11		15			
KEY A, BLACK	33476-2267	A									P			2	3	4	5									13	14	15	
KEY A, BLACK	33476-2266	A									P			2									10	11	12	13	14		
KEY A, BLACK	33476-2265	A									P			2									11			13			
KEY A, BLACK	33476-2264	A									P			2									11			13			
KEY B, LT. GRAY	33476-2263	B									P					4							6		13				
KEY A, BLACK	33476-2262	A									P															13			
KEY A, BLACK	33476-2261	A									P					3							5		10	11			
KEY A, BLACK	33476-2260	A																											

