

TW2880C2

Multi-Channel Surveillance Camera Controller with VGA/HDTV Display Capability

FN7883
 Rev. 2.00
 June 4, 2013

Summary

Display Controller Features List

- Video Input from Decoder Interface
 - Supports 27 MHz BT.656 input
 - Supports 54,108 MHz BT.656 byte-interleaved input
 - Supports 4 BT.656 play back input in frame interleaved or field interleaved format
 - Supports 4 BT.1120 play back input with FPGA
 - Motion Box (MD) on all display channels
- Supports 1080p HDTV and VGA Display
 - Horizontal size: 640 ~ 1920, Vertical size: 480 ~ 1080
 - Max. pixel clock: 174 MHz (if MCLK > 166 MHz)
 - Vertical Refresh frequency: Flexible, can be programmed as 50 or 60 Hz
 - Flexible output interface, Analog VGA (HD15), Digital VGA (DVI) and HDMI (V1.2)
 - Capable of displaying up to 33 Channels in one screen, logo, live video or playback combined
 - User selectable Weave/2D/3D de-interlacing method for video quality enhancement
 - Up / down scaler for arbitrary windows size
 - Three layers of OSG overlay with High-color (16 bit) bit map
 - Play back channel input can be used as an external OSG layer
 - OSD display layer for title and channel ID
 - Single Box Display for highlighting and Mouse / Cursor Overlay
- System clock at 108MHz, Memory clock 166 - 180 MHz
- I²C and parallel MCU host interface

Recording Controller Features List

- High flexibility record output function
 - Real time / non real time field interleaved, frame interleaved output
 - Priority recording
 - Multi-mode output controlled by user
- High flexibility SPOT output function
 - Four individual output
 - Full / Half / CIF display with OSD
 - Automatic switching
- Random sequence recording (Table recording) function
- Motion Detector & Channel ID Encoding / Decoding
- Embedded font-RAM for color OSD
- Split border and background color setting
- Four privacy windows on every channel
- Four SPOT with flexible channel arrangement

Ordering Information

PART NUMBER	PART MARKING	PACKAGE (Pb-free)
TW2880P-BC2-GR (Note 1)	TW2880P PKBC2-GR	676 Pin BGA
TW2880N-BC2-GR (Note 1)	TW2880N PKBC2-GR	676 Pin BGA

NOTE:

1. These Intersil Pb-free WLCSP and BGA packaged products employ special Pb-free material sets; molding compounds/die attach materials and SnAgCu - e1 solder ball terminals, which are RoHS compliant and compatible with both SnPb and Pb-free soldering operations. Intersil Pb-free WLCSP and BGA packaged products are MSL classified at Pb-free peak reflow temperatures that meet or exceed the Pb-free requirements of IPC/JEDEC J STD-020.

Table of Contents

Summary.....	1
Display Controller Features List	1
Recording Controller Features List	1
Ordering Information.....	2
Table of Contents.....	3
Display Format.....	36
System Diagram.....	37
Ball Description.....	38
Ball Diagrams	50
AC/DC Electrical Parameters	55
Absolute Maximum Ratings.....	55
Recommended Operating Conditions	55
Supply Current and Power Dissipation	55
PLL AC Parameters	56
DC Characteristics	56
Analog Performance Parameter	57
3.3V CMOS Output I/O, M-type V-I Characteristics	57
Chip Package	58
Different Versions of TW2880.....	58
Video Interface and Down Scaler	59
Digital Video Input.....	59
Byte-interleaved Format.....	60
Down Scaler for Live Inputs	60
AC Timing for Live and PB Input	60
Register Table.....	61
Registers	70
Live Video Channel 1 Horizontal Scaler Low Byte Register – 0x300	70
Live Video Channel 1 Horizontal Scaler High Byte Register – 0x301	70
Live Video Channel 1 Vertical Scaler Low Byte Register – 0x320	70
Live Video Channel 1 Vertical Scaler High Byte Register – 0x321	70
Live Video Vertical Scale Mode Register – 0x340.....	71
Live Video Horizontal Scale Mode Register – 0x348.....	71
Live Video PAL Delay Mode Register – 0x350.....	71
Live Video Odd Field Skew Register – 0x352	71
Live Video Vertical Scaler LPF Register – 0x354.....	72
Live Video Vertical Scale VAV Test Register – 0x356	72
Live Video Channel 1 Horizontal pixel adjustment Register – 0x375.....	72
Live Video Channel 1 Horizontal pixel adjustment Register – 0x385.....	72
Live Video Channel 1 Vertical pixel adjustment Register – 0x395.....	72
Live Video Channel 1 Vertical pixel adjustment Register – 0x3A5.....	73
Live Video Channel 1~4 No Video Register – 0x3BD.....	73
Live Video Channel 1~4 Non Standard Register – 0x3C1	73
Live Video Channel Control Register – 0x3C5.....	74
Live Video Channel System Select Register – 0x3C6.....	74
Live/Record Channel Select Register – 0x3D2	74
Live/Record Set Select Register – 0x3DA.....	75
Play Back Interface	76
Introduction	76
Features	76
Description	76
Play Back Architecture.....	76
Functions	79
Input Formatter.....	79

Registers Table	80
Registers Description.....	84
Toggle Field Signal Enable Register – 0x357	84
PB1 Vertical Target Size LSB Register – 0x358	84
PB1 and PB2 Vertical Target Size MSB Register – 0x359.....	84
PB2 Vertical Target Size LSB Register – 0x35A	84
PB1 Vertical Source Size LSB Register – 0x35E.....	85
PB1 and PB2 Vertical Source Size MSB Register – 0x35F	85
PB2 Vertical Source Size LSB Register – 0x360	85
PB1 Horizontal Scaler Target LSB Register – 0x364.....	85
PB1 and PB2 Horizontal Target Size MSB Register – 0x365	85
PB2 Horizontal Scaler Target LSB Register – 0x366.....	86
PB1 Horizontal Scaler Source LSB Register – 0x36A.....	86
PB1 and PB2 Horizontal Source Size MSB Register – 0x36B	86
PB2 Horizontal Scaler Source LSB Register – 0x36C.....	86
PB Auto Downscale and Bypass Register – 0x370.....	87
PB MISC Control Register – 0x371.....	87
Horizontal Delay for Playback Port 1 Register – 0x3B5.....	88
Vertical Delay for Playback Port 1 Register – 0x3B6	88
PB Path Selection Register – 0x3DB.....	88
PB In_PB_Test Register – 0x3DC.....	88
PB In_PB_Test Pattern Generator Color Bar Shift Volum – 0x3DD.....	89
PB Channel ID Dec PB1 Ctrl – 0x3DE.....	89
PB Channel ID Dec PB1 VOS – 0x3DF.....	90
PB Channel ID Dec PB1 FOS – 0x3E0	90
PB Channel ID Dec PB1 HOS – 0x3E1	90
PB Channel ID Dec PB1 MID_VAL – 0x3E2.....	90
PB Frame/Field Control Register – 0x3F2	90
PB Field Mode Register – 0x3F3.....	91
PB Digital Channel ID Enable Register – 0x3F4	91
Non-standard Video Upper Limit - NTSC Register – 0x3F8	91
Non-standard Video Lower Limit - NTSC Register – 0x3F9.....	91
Non-standard Video Upper Limit - PAL Register – 0x3FA	91
Non-standard Video Lower Limit - PAL Register – 0x3FB	91
PB CHID Decoder Control Register – 0x3FC.....	92
Analog Channel ID Line Number Register 1 – 0x3FD.....	92
Analog Channel ID Line Number Register 2 – 0x3FE	92
MISC. Control Register – 0x3FF.....	92
PB Channel ID Dec Read Bus PB1 Byte 1– 0x372	93
PB Channel ID Dec Read Bus PB1 Byte 2 – 0x373	94
PB Channel ID Dec Read Bus PB1 Byte 3 – 0x374	95
PB Channel ID Dec Read Bus PB1 Byte 4 – 0x3C7	95
PB Channel ID Dec Read Bus PB1 Byte 5 – 0x3C8	96
Video Write Buffer (RGBW)	97
Introduction	97
Window Control	97
Display Map Control.....	97
Play Back Channels	98
Register Table.....	99
Register	106
Display Write Buffer Control Register – 0x600.....	106
Display Write Buffer Vertical Position Register A – 0x614	106
Display Write Buffer Vertical Position Register B – 0x615.....	106
Display Write Buffer Vertical Size Register A – 0x63C	106
Display Write Buffer Vertical Size Register B – 0x63D.....	106
Display Write Buffer Horizontal Position Register A – 0x664	107

Display Write Buffer Horizontal Position Register B – 0x665	107
Display Write Buffer Horizontal Size Register A – 0x68C	107
Display Write Buffer Horizontal Size Register B – 0x68D	107
Display Write Buffer Control Register 1 – 0x6B4	108
Test Pattern Timing Replace Register 1 – 0x6B5	108
Misc Control Register – 0x6B6	108
PB First Channel Number Register 1 – 0x6B7	109
PB First Channel Number Register 2 – 0x6B8	109
PB First Channel Number Enable Register – 0x6B9	109
Test Pattern Timing Replace Register 2 – 0x6BA	109
PB Channel Freeze Register 1 – 0x6BB	110
PB Channel Freeze Register 2 – 0x6BC	110
Protection Address Register 1 – 0x6BD	110
Protection Address Register 2 – 0x6BE	110
Protection Address Register 3 – 0x6BF	110
Display Write Buffer Horizontal Start – 0x6C0	110
Display Write Buffer Vertical Start – 0x6D4	110
Live Channel Frame Rate Correction Control Register 1 – 0x6E8	111
Live Channel Frame Rate Correction Control Register 2 – 0x6E9	111
Live Channel Frame Rate Correction Control Register 3 – 0x6EA	111
Live Channel Frame Rate Correction Control Register 4 – 0x6EB	111
Live Channel Frame Rate Correction Control Register 1 – 0x6EC	111
Live Channel Frame Rate Correction Control Register 2 – 0x6ED	111
Live Channel Frame Rate Correction Control Register 7 – 0x6EE	112
Live Channel Frame Rate Correction Control Register 8 – 0x6EF	112
PB0 Line Number Status Register 1 – 0x6F0 (Read Only)	112
PB0 Line Number Status Register 2 – 0x6F1 (Read Only)	112
PB Channel Frame Rate Correction Control Register 1 – 0x6F0	112
PB Channel Frame Rate Correction Control Register 2 – 0x6F1	112
PB Valid Status Register – 0x6F8	113
Live channel External Correction Period Register – 0x6F9	113
PB Channel Ignore and Free Running Register – 0x6FA	113
FIFO Count Limit Register – 0x6FB	113
Vertical Inverter Method Selection – 0x6FC	114
Auto Mode PB Channel Enable Register 1 – 0x6FD	114
Auto Mode PB Channel Enable Register 2 – 0x6FE	114
Live channel Internal Correction Period Register – 0x6FF	114
DRAM Control Unit (DCU)	115
Introduction	115
Memory Organization	115
Display Plane and DRAM Arrangement	116
DCU Handshake	117
TW2880 DRAM Configuration Options	117
Display Path, 64 bit, 256 Mbit, 8Mx32x2 (suggested)	118
Display Path, 64 bit, 128 Mbit, 4Mx32x2 (suggested)	118
Display Path, 64 bit, 64 Mbit, 2Mx32x2	118
Display Path, 32 bit, 128 Mbit, 4Mx32x1	118
Display Path, 32 bit, 64 Mbit, 2Mx32x1 (not recommended)	119
Recording Path, 64 bit, 256 Mbit, 8Mx32x2 (suggested)	119
Recording Path, 64 bit, 128 Mbit, 4Mx32x2	119
Recording Path, 64 bit, 64 Mbit, 2Mx32x2	119
Recording Path, 32 bit, 256 Mbit, 8Mx32x1	119
Recording Path, 32 bit, 128 Mbit, 4Mx32x1	120
Recording Path, 32 bit, 64 Mbit, 2Mx32x1	120
TW2880 DRAM Parameter Adjustments	121
Command and address timing	121

Data read / write timing	123
Refresh options	124
Frame Rate Control Unit	124
Introduction	124
SDRAM Allocation	124
Read Buffer ID Calculation	124
Write Buffer ID Calculation	125
VGA Controller and Video interface	126
Introduction	126
Features	127
Frame Buffer Controller	127
Output Interface	127
VGA Interface	128
Block Diagram	129
Display Layers	129
Display Resolutions	130
De-interlacing	130
Upscale	130
Mouse Interface	131
Motion Box	132
Single Box	133
Peak Function	133
OSG Layer	133
Simple OSD	133
Background and Channel Boundary	133
Digital Gain	134
Register Table	135
Register	147
De-interlace Mode Selection Register 1 - 0x400	147
Error Buffer Base Low Byte Register - 0x401	147
Error Buffer Base Middle Byte Register - 0x402	147
Error Buffer Base High Byte Register - 0x403	148
Height of one Field in Buffer Register low byte - 0x404	148
Height of one Field in Buffer Register high byte - 0x405	148
Width of one Field in Buffer Register low byte - 0x406	148
Width of one Field in Buffer Register high byte - 0x407	148
3D De-interlace ditb0 Register - 0x408	148
3D De-interlace ditb4 Register - 0x409	148
3D De-interlace ditb8 Register - 0x40A	149
3D De-interlace ditb12 Register - 0x40B	149
3D De-interlace ditb16 Register - 0x40C	149
3D De-interlace ditb24 Register - 0x40D	149
3D De-interlace ditb32 Register - 0x40E	149
3D De-interlace ditb48 Register - 0x40F	149
3D De-interlace afm_yf02_thd Register - 0x410	149
3D De-interlace afm_yf02_h_thd Register - 0x411	149
3D De-interlace afm_yf01_thd Register - 0x412	149
3D De-interlace afm_yf01_h_thd Register - 0x413	149
3D De-interlace 32 Caption Threshold Register - 0x414	150
Up-scale Control Register - 0x415	150
Up-scale Background Color - 0x416	150
Up-scale Horizontal Factor low byte Register - 0x417	150
Up-scale Horizontal Factor high byte Register - 0x418	151
Up-scale Vertical Factor low byte Register - 0x419	151
Up-scale Vertical Factor high byte Register - 0x41A	151
Up-scale Horizontal Start low byte Register - 0x41B	151

Up-scale Horizontal Start high byte Register – 0x41C.....	151
Up-scale Vertical Start low byte Register – 0x41D.....	152
Up-scale Vertical Start high byte Register – 0x41E.....	152
Up-scale Output Width low byte Register – 0x41F.....	152
Up-scale Output Width high byte Register – 0x420.....	152
Up-scale Output Height low byte Register – 0x421.....	152
Up-scale Output Height high byte Register – 0x422.....	152
Up-scale X Boundary Width Register – 0x423.....	153
Up-scale Y Boundary Width Register – 0x424.....	153
Up-scale Panorama / Water Glass Control Register – 0x425.....	153
Up-scale Horizontal Center Scale Factor low byte Register – 0x426.....	153
Up-scale Horizontal Center Scale Factor high byte Register – 0x427.....	154
2D De-interlace Control Register – 0x428.....	154
2D De-interlace Threshold 1 Register – 0x429.....	154
2D De-interlace Threshold 2 Register – 0x42A.....	154
2D De-interlace Threshold 3 Register – 0x42B.....	154
2D De-interlace Threshold 4 Register – 0x42C.....	154
2D De-interlace Threshold 5 Register – 0x42D.....	154
2D De-interlace Threshold 6 Register – 0x42E.....	154
3D De-interlace Control Register – 0x42F.....	154
3D De-interlace Threshold 1 Register – 0x430.....	155
3D De-interlace Threshold 2 Register – 0x431.....	155
Upscaler Option Register – 0x432.....	155
Single Box 4 to 7 Register – 0x440 to 0x46B.....	155
Mouse Base Address Low Byte Register – 0x46C.....	155
Mouse Base Address Middle Byte Register – 0x46D.....	155
Mouse Base Address High Byte Register – 0x46E.....	155
Mouse Update Enable Register – 0x46F.....	156
Mouse Index Register – 0x470.....	156
Window 32 Vertical Position Register Low Byte – 0x472.....	156
Window 32 Horizontal Position Register Low Byte – 0x473.....	156
Window 32 Vertical Size Register Low Byte – 0x474.....	156
Window 32 Horizontal Size Register Low Byte – 0x475.....	157
Window 32 Vertical and Horizontal Position Register High Byte – 0x476.....	157
Window 32 Vertical and Horizontal Size Register High Byte – 0x477.....	157
Window 32 Enable Register – 0x47E.....	157
Display MISC. Control Register – 0x480.....	158
Vertical Sync Delay and Boundary Width Register – 0x481.....	158
Boundary Red Color Intensity Register – 0x482.....	158
Boundary Green Color Intensity Register – 0x483.....	159
Boundary Blue Color Intensity Register – 0x484.....	159
Horizontal Upscale Factor Low Byte Register – 0x485.....	159
Horizontal Upscale Factor High Byte Register – 0x486.....	159
Vertical Upscale Factor Low Byte Register – 0x487.....	159
Vertical Upscale Factor High Byte Register – 0x488.....	159
Position Upscale Enable Register – 0x489.....	160
OSD Blink Rate Register – 0x48A.....	160
Motion Box Cursor Vertical Position Register – 0x48B.....	160
Motion Box Out Boundary Red Color Register – 0x493.....	160
Motion Box Out Boundary Green Color Register – 0x494.....	160
Motion Box Out Boundary Blue Color Register – 0x495.....	160
Motion Box Inner Boundary Red Color Register – 0x496.....	161
Motion Box Inner Boundary Green Color Register – 0x497.....	161
Motion Box Inner Boundary Blue Color Register – 0x498.....	161
Motion Box Mask Red Color Register – 0x499.....	161
Motion Box Mask Green Color Register – 0x49A.....	161
Motion Box Mask Blue Color Register – 0x49B.....	161

Motion Box Plane Red Color Register – 0x49C	161
Motion Box Plane Green Color Register – 0x49D.....	162
Motion Box Plane Blue Color Register – 0x49E.....	162
Horizontal Start Low Byte Register – 0x4A0.....	162
Horizontal Start High Byte Register – 0x4A1.....	162
Vertical Start Low Byte Register – 0x4A2.....	162
Vertical Start High Byte Register – 0x4A3.....	162
rti Wndow Register – 0x4A4.....	162
Vertical Total Adjust Mode Register – 0x4A5	163
Vertical Total from Input Video Low Byte Register – 0x4A6.....	163
Vertical Total from Input Video High Byte Register – 0x4A7	163
Vertical Total after Adjustment Byte Register – 0x4A8.....	163
Vertical Total after Adjustment High Register – 0x4A9	163
Boundary Enable Register – 0x4AA.....	164
PS2 Mouse Control Register – 0x4B4	164
PS2 Mouse Write Data Register – 0x4B5	164
PS2 Mouse Write Data Register 1– 0x4B6	164
PS2 Mouse Write Data Register 2– 0x4B7	164
PS2 Mouse Write Data Register 3– 0x4B8	164
PS2 Mouse Write Data Register 4– 0x4B9	165
PS2 Interrupt Register– 0x4BA	165
External OSD Control Register– 0x4BB.....	165
External OSD Alpha Register– 0x4BC	165
External OSD Color R Register– 0x4BD	165
External OSD Color G Register– 0x4BE.....	166
External OSD Color B Register– 0x4BF	166
Interrupt Mask Register– 0x4C0.....	166
Interrupt Status Register– 0x4C1	166
Frame Rate Control Debug Register– 0x4C2.....	167
Misc Control Register – 0x4C3	167
Boundary Enable Register 2 – 0x4C4	168
Image control Register – 0x4CE.....	168
Peak Control Register – 0x4D0.....	168
Digital R Gain Register – 0x4DA	169
Digital G Gain Register – 0x4DB	169
Digital B Gain Register – 0x4DC	169
R Offset Register – 0x4DD	169
G Offset Register – 0x4DE.....	169
B Offset Register – 0x4DF.....	169
Boundary Channel Enable Register 1 – 0x4F0	170
Boundary Channel Enable Register 2 – 0x4F1.....	170
Boundary Channel Enable Register 3 – 0x4F2	170
Boundary Channel Enable Register 4 – 0x4F3	170
Frame Rate Control Enable Register 1 – 0x4F4.....	170
Frame Rate Control Enable Register 2 – 0x4F5.....	170
Frame Rate Control Enable Register 3 – 0x4F6.....	170
Frame Rate Control Enable Register 4 – 0x4F7.....	171
Red Color for No Video Channel – 0x4F8	171
Green Color for No Video Channel – 0x4F9.....	171
Blue Color for No Video Channel – 0x4FA	171
Horizontal Total Register 1 – 0x500.....	171
Horizontal Total Register 2 – 0x501.....	171
Vertical Total Register 1 – 0x502	172
Vertical Total Register 2 – 0x503	172
Horizontal Display End Register 1 – 0x504.....	172
Horizontal Display End Register 2 – 0x505.....	172
Vertical Display End Register 1 – 0x506	172

Vertical Display End Register 2 – 0x507	172
Horizontal Sync Starting position Register – 0x508	173
Vertical Sync Starting position Register – 0x509	173
Horizontal Sync Width Register – 0x50A	173
Vertical Sync Width Register – 0x50B	173
SBOX0 Control Register – 0x50C	173
SBOX Line Width Control Register 1 – 0x511	174
SBOX Line Width Control Register 2 – 0x512	174
SBOX0 HL Control Register 1 – 0x513	175
SBOX0 HL Control Register 2 – 0x514	175
SBOX0 HR Control Register 1 – 0x51B	175
SBOX0 HR Control Register 2 – 0x51C	175
SBOX0 VT Control Register 1 – 0x523	175
SBOX0 VT Control Register 2 – 0x524	175
SBOX0 VB Control Register 1 – 0x52B	175
SBOX0 VB Control Register 2 – 0x52C	175
BOX Boundary Color R byte – 0x533	175
BOX Boundary Color G byte – 0x534	175
BOX Boundary Color B byte – 0x535	176
BOX Plane Color R byte – 0x536	176
BOX Plane Color G byte – 0x537	176
BOX Plane Color B byte – 0x538	176
Screen Background Color R byte – 0x539	176
Screen Background Color G byte – 0x53A	176
Screen Background Color B byte – 0x53B	176
MOUSE0 Horizontal Position Register 1 – 0x53C	176
MOUSE0 Horizontal Position Register 2 – 0x53D	176
MOUSE0 Vertical Position Register 1 – 0x53E	176
MOUSE0 Vertical Position Register 2 – 0x53F	177
MOUSE1 Horizontal Position Register 1 – 0x540	177
MOUSE1 Horizontal Position Register 2 – 0x541	177
MOUSE1 Vertical Position Register 1 – 0x542	177
MOUSE1 Vertical Position Register 2 – 0x543	177
MOUSE Control Register – 0x544	177
Mouse Background Color R byte – 0x545	178
Mouse Background Color G byte – 0x546	178
Mouse Background Color B byte – 0x547	178
Mouse Foreground Color R byte – 0x548	178
Mouse Foreground Color G byte – 0x549	178
Mouse Foreground Color B byte – 0x54A	178
Display Mode Control Register – 0x54B	178
Mouse RAM Address Register – 0x54C	179
Mouse RAM Data Register – 0x54D	179
Mouse Register Update Enable Register – 0x54E	179
Mouse RAM Write Enable Register – 0x54F	179
MD BOX Control Register 0 – 0x550	179
MD BOX Line Width Control Register 0 – 0x560	180
MD BOX 0 Horizontal Left Position Register 1 – 0x568	180
MD BOX 0 Horizontal Left Position Register 2 – 0x569	181
MD BOX 0 Vertical Top Position Register 1 – 0x588	181
MD BOX 0 Vertical Top Position Register 2 – 0x589	181
MD BOX 0 Horizontal Size Register 1 – 0x5A8	181
MD BOX 0 Horizontal Size Register 2 – 0x5A9	181
MD BOX 0 Vertical Size Register 1 – 0x5C8	181
MD BOX 0 Vertical Size Register 2 – 0x5C9	182
MD BOX HCELL Register 0 – 0x5E8	182
MD BOX VCELL Register 0 – 0x5F0	182

MD BOX Cursor Horizontal Position Register 0 – 0x5F8	182
HDMI Controller	183
Introduction	183
Physical Port	184
Control and Configuration	184
Registers/Configuration Logic	184
Slave I ² C Interface	184
Audio Data Capture Logic	185
S/PDIF	185
I ² S	185
TMDS Digital Core	185
DDC Master I ² C Interface	185
Register Grouping	187
Usages and Conventions	187
Base Register Set	188
Vendor ID Register	188
Device ID Register	188
Device Revision Register	188
Software Reset Register	188
System Control Register #1	189
System Status Register	189
Legacy Registers	189
Data Control Register	190
Automatic Ri Check	190
Ri Status Register	190
Ri Command Register	191
Ri Line Start Register	191
Ri From RX Register	191
DE Generator Register Set	191
Video DE Delay Register	192
Video DE Control Register	193
Video DE Top Register	193
Video DE Count Register	193
Video DE Line Register	194
Video H Resolution Register	194
Video V Refresh Register	194
Video Embedded Sync Decoding Registers	195
Video Interface Adjustment Register	195
Video SYNC Polarity Detection Register	195
Video Hbit to HSYNC Register	196
Video Field2 HSYNC Offset Register	196
Video HSYNC Length Register	196
Video Vbit to VSYNC Register	196
Video VSYNC Length Register	197
Video Control Register	197
Video Mode Register	198
Interrupt Registers	199
Interrupt State Register	199
Interrupt Source Register	199
Interrupt Unmask Register	201
Interrupt Control Register	201
TMDS Control Register Set	202
TMDS Control Register	202
DDC Master Registers	205
DDC I ² C Manual Register	205
DDC I ² C Target Slave Address Register	205

DDC I ² C Target Segment Address Register	205
DDC I ² C Target Offset Address Register.....	205
DDC I ² C Data Count Register	206
DDC I ² C Status Register.....	206
DDC I ² C Command Register.....	206
DDC I ² C Data Register.....	207
DDC I ² C FIFO Count Register.....	207
Audio Registers.....	208
ACR Control Register.....	208
ACR Audio Frequency Register	208
ACR N Software Value Register.....	208
ACR CTS Software Value Register.....	209
ACR CTS Hardware Value Registers.....	209
Audio In Mode Register.....	209
Audio In S/PDIF Control Register	210
Audio In S/PDIF Extracted Fs and Length Register	210
Audio In I ² S Channel Swap Register	210
Audio Error Threshold Register	211
Audio In I ² S Data In Map Register.....	211
Audio In I ² S Control Register.....	212
Audio In I ² S Channel Status Registers	212
Audio Sample Rate Conversion Register	213
Audio I ² S Input Length Register	214
HDMI Control Register.....	214
Audio Path Status Register	215
Diagnostic Power Down Register	215
Packet Registers	216
Packet Buffer Control #1 Register	217
Packet Buffer Control #2 Register	217
Packet Registers.....	218
SPD InfoFrame Registers	218
Audio InfoFrame Registers.....	219
MPEG InfoFrame Registers	220
Generic Packet Registers	221
General Control Packet Register.....	222
Generic Packet #2 Registers	222
Appendices	223
Handling Audio	224
Enabling Audio Inputs	224
Encoding Audio on HDMI	225
Handling DVD Audio.....	226
Sink Support for Audio Content Protection	226
Transmitting ACP Packets.....	226
Handling Video.....	228
Programming Video Input Mode and Video Output Mode	228
Handling Interlaced Video	231
Summary of Video Processing Path Options	232
480i Input	233
480i Muxed YCbCr 4:2:2 Embedded Sync Input.....	233
480i Muxed YCbCr 4:2:2 Embedded Sync Input – Fixing for CEA-861B.....	234
480i YCbCr 4:2:2 Mux YC Separate Sync Input	235
576i Input	236
576i YCbCr 4:2:2 Embedded Sync Input.....	236
576i YCbCr 4:2:2 Embedded Sync Input – Fixing for CEA-861B.....	237
780p Input	238
720p RGB Input	238
720p YCbCr 4:4:4 Separate Sync Input	239

720p YCbCr 4:2:2 Separate Sync Input	240
720p YCbCr 4:2:2 Embedded Sync Input	241
720p YCbCr 4:2:2 Embedded Sync Input – Fixing for CEA-861B.....	242
1080i Input	243
1080i RGB Input	243
1080i YCbCr 4:4:4 Separate Sync Input	244
1080i YCbCr 4:2:2 Separate Sync Input	245
1080i YCbCr 4:2:2 Embedded Sync Input	246
1080i YCbCr 4:2:2 Embedded Sync Input – Fixing for CEA-861B	247
1080p YCbCr 4:4:4 Separate Sync Input	248
1080p YCbCr 4:2:2 Separate Sync Input	249
1080p YCbCr 4:2:2 Embedded Sync Input	250
1080p YCbCr 4:2:2 Embedded Sync Input – Fixing for CEA-861B	251
Handling InforFrames	252
AVI InforFrames	252
General Control Packets	254
Handling Audio Content Protection (ACP) Packets	254
Operating DDC Master	255
Device Addresses	255
DDC Read Operation	256
Write Command	258
Abort Command	258
Power Down Control	259
Logic Blocks Affected by Power Down	259
Registers Affected by Power Down	259
OSG for Display Path	260
Introduction	260
Features	260
OSG Graphic Buffer	260
Memory Diagram	260
Bitmap Buffer	261
Write Memroy by Host.....	262
Block Transfer	262
Block Fill	262
BitBlit	262
De-compression	263
Pixel Bit Extension	264
Color Conversion	264
Selective Overwrite	264
Pixel Operation Sequence	264
Bitmap Buffer Display.....	264
Eight Sub-windows.....	265
Transparent.....	266
Alpha Blending.....	266
Blinking	266
RGB Format	266
Upscale	267
Host write buffer threshold setting	268
Host Write Data Sequence	269
Registers Table	270
Register Descriptions.....	274
OSG Control Register – 0x100	274
OSG Status Register 2 – 0x101	274
OSG Mode Register 1 – 0x102	274
OSG Mode Register 2 – 0x103	275
OSG BitBlit Operation Register – 0x104.....	276

OSG Display Window 1 Control Register - 0x105.....	276
OSG Display Window 2 Control Register - 0x106.....	276
OSG Alpha Blending Register - 0x107	277
OSG Alpha Blending Color Low Byte Register - 0x108.....	277
OSG Alpha Blending Color High Byte Register - 0x109.....	277
OSG Alpha Blending Color Low Byte Register - 0x10A.....	277
OSG Alpha Blending Color High Byte Register - 0x10B.....	278
OSG Alpha Blending Color Low Byte Register - 0x10C.....	278
OSG Alpha Blending Color High Byte Register - 0x10D.....	278
OSG Alpha Blending Color Low Byte Register - 0x10E.....	278
OSG Alpha Blending Color High Byte Register - 0x10F.....	278
OSG Blinking Foreground Color Low Byte Register - 0x110	278
OSG Blinking Foreground Color High Byte Register - 0x111.....	278
OSG Blinking Foreground Color Low Byte Register - 0x112	279
OSG Blinking Foreground Color High Byte Register - 0x113.....	279
OSG Fill Color Low Byte - 0x114.....	279
OSG Fill Color High Byte - 0x115.....	279
OSG Overwrite Color Low Byte - 0x116.....	279
OSG Overwrite Color High Byte - 0x117.....	279
OSG Color Conversion Source Color 1 Low Byte - 0x118.....	279
OSG Color Conversion Source Color 1 High Byte - 0x119	280
OSG Color Conversion Target Color 1 Low Byte - 0x11A.....	280
OSG Color Conversion Target Color 1 High Byte - 0x11B.....	280
OSG Color Conversion Source Color 2 Low Byte - 0x11C.....	280
OSG Color Conversion Source Color 2 High Byte - 0x11D.....	280
OSG Color Conversion Target Color 2 Low Byte - 0x11E.....	280
OSG Color Conversion Target Color 2 High Byte - 0x11F	280
OSG Color Conversion Source Color 3 Low Byte - 0x120.....	281
OSG Color Conversion Source Color 3 High Byte - 0x121.....	281
OSG Color Conversion Target Color 3 Low Byte - 0x122.....	281
OSG Color Conversion Target Color 3 High Byte - 0x123.....	281
OSG Color Conversion Source Color 4 Low Byte - 0x124.....	281
OSG Color Conversion Source Color 4 High Byte - 0x125.....	281
OSG Color Conversion Target Color 4 Low Byte - 0x126.....	281
OSG Color Conversion Target Color 4 High Byte - 0x127	282
OSG Bitmap Buffer Horizontal Size Low Byte - 0x128	282
OSG Bitmap Buffer Horizontal Size High Byte - 0x129.....	282
OSG Bitmap Buffer Source Window 1 Vertical Start Low Byte - 0x12A.....	282
OSG Bitmap Buffer Source Window 1 Vertical Start High Byte - 0x12B.....	282
OSG Bitmap Buffer Source Window 1 Horizontal Start Low Byte - 0x12C.....	282
OSG Bitmap Buffer Source Window 1 Horizontal Start High Byte - 0x12D.....	283
OSG Bitmap Buffer Source Window 1 Vertical Size Low Byte - 0x12E.....	283
OSG Bitmap Buffer Source Window 1 Vertical Size High Byte - 0x12F	283
OSG Bitmap Buffer Source Window 1 Horizontal Size Low Byte - 0x130	283
OSG Bitmap Buffer Source Window 1 Horizontal Size High Byte - 0x131	283
OSG Bitmap Buffer Target Window Vertical Start Low Byte - 0x132	283
OSG Bitmap Buffer Target Window Vertical Start High Byte - 0x133	284
OSG Bitmap Buffer Target Window Horizontal Start Low Byte - 0x134	284
OSG Bitmap Buffer Target Window Horizontal Start High Byte - 0x135	284
OSG Bitmap Buffer Source Window 2 Vertical Start Low Byte - 0x136.....	284
OSG Bitmap Buffer Source Window 2 Vertical Start High Byte - 0x137.....	284
OSG Bitmap Buffer Source Window 2 Horizontal Start Low Byte - 0x138.....	284
OSG Bitmap Buffer Source Window 2 Horizontal Start High Byte - 0x139.....	285
OSG Host Write Data Port - 0x13A	285
OSG Bitmap Buffer Start Address Low Byte - 0x13B.....	285
OSG Bitmap Buffer Start Address Middle Byte - 0x13C.....	285
OSG Bitmap Buffer Start Address High Byte - 0x13D.....	285

OSG FORMAT Control – 0x17E	286
OSG Bitmap Buffer Start Address High Byte – 0x13D.....	286
OSG Window 1 Vertical Start in Bitmap Buffer Low Byte – 0x144.....	286
OSG Window 1 Vertical Start in Bitmap Buffer High Byte – 0x145.....	286
OSG Window 1 Horizontal Start in Bitmap Buffer Low Byte – 0x146.....	286
OSG Window 1 Horizontal Start in Bitmap Buffer High Byte – 0x147	287
OSG Window 1 Vertical Size Low Byte – 0x148	287
OSG Window 1 Vertical Size High Byte – 0x149.....	287
OSG Window 1 Horizontal Size Low Byte – 0x14A.....	287
OSG Window 1 Horizontal Size High Byte – 0x14B.....	287
OSG Window 1 Vertical Start On Screen Low Byte – 0x14C.....	287
OSG Window 1 Vertical Start On Screen High Byte – 0x14D	287
OSG Window 1 Horizontal Start On Screen Low Byte – 0x14E	288
OSG Window 1 Horizontal Start On Screen High Byte – 0x14F	288
OSG Window 2 Vertical Start in Bitmap Buffer Low Byte – 0x150.....	288
OSG Window 2 Vertical Start in Bitmap Buffer High Byte – 0x151.....	288
OSG Window 2 Horizontal Start in Bitmap Buffer Low Byte – 0x152	288
OSG Window 2 Horizontal Start in Bitmap Buffer High Byte – 0x153	288
OSG Window 2 Vertical Size Low Byte – 0x154	289
OSG Window 2 Vertical Size High Byte – 0x155.....	289
OSG Window 2 Horizontal Size Low Byte – 0x156.....	289
OSG Window 2 Horizontal Size High Byte – 0x157.....	289
OSG Window 2 Vertical Start On Screen Low Byte – 0x158.....	289
OSG Window 2 Vertical Start On Screen High Byte – 0x159.....	289
OSG Window 2 Horizontal Start On Screen Low Byte – 0x15A	290
OSG Window 2 Horizontal Start On Screen High Byte – 0x15B	290
OSG Overwrite Color2 Low Byte – 0x15C	290
OSG Overwrite Color2 High Byte – 0x15D	290
OSG Overwrite Color3 Low Byte – 0x15E.....	290
OSG Overwrite Color3 High Byte – 0x15F.....	290
OSG Overwrite Color4 Low Byte – 0x160	291
OSG Overwrite Color4 High Byte – 0x161	291
OSG Vertical Blank Register – 0x162.....	291
OSG Display Window 3 Control Register – 0x163.....	291
OSG Alpha Blending Register – 0x164	292
OSG Alpha Blending Color Low Byte Register – 0x165.....	292
OSG Alpha Blending Color High Byte Register – 0x166.....	292
OSG Alpha Blending Color Low Byte Register – 0x167.....	292
OSG Alpha Blending Color High Byte Register – 0x168.....	293
OSG Blinking Foreground Color Low Byte Register – 0x169	293
OSG Blinking Foreground Color High Byte Register – 0x16A	293
OSG Display Window 1 Enable Register – 0x16B.....	293
OSG Display Window 2 Enable Register – 0x16C.....	293
OSG Display Window 3 Enable Register – 0x16D.....	293
OSG Display Window 1 and 2 Select Register – 0x16E	294
OSG Display Window 3 Select Register – 0x16F.....	294
OSG Window 3 Vertical Start in Bitmap Buffer Low Byte – 0x170.....	294
OSG Window 3 Vertical Start in Bitmap Buffer High Byte – 0x171.....	294
OSG Window 3 Horizontal Start in Bitmap Buffer Low Byte – 0x172.....	294
OSG Window 3 Horizontal Start in Bitmap Buffer High Byte – 0x173	295
OSG Window 3 Vertical Size Low Byte – 0x174	295
OSG Window 3 Vertical Size High Byte – 0x175.....	295
OSG Window 3 Horizontal Size Low Byte – 0x176.....	295
OSG Window 3 Horizontal Size High Byte – 0x177.....	295
OSG Window 3 Vertical Start On Screen Low Byte – 0x178.....	295
OSG Window 3 Vertical Start On Screen High Byte – 0x179.....	295
OSG Window 3 Horizontal Start On Screen Low Byte – 0x17A	296

OSG Window 3 Horizontal Start On Screen High Byte - 0x17B	296
OSG Threshold 1 - 0x17C	296
OSG Threshold 2 - 0x17D	296
OSG FORMAT Control - 0x17E	296
OSG FORMAT Control - 0x17F	297
OSG Original Vertical Size for Window 1 Low Byte- 0x1C0.....	297
OSG Original Vertical Size for Window 1 High Byte - 0x1C1.....	297
OSG Original Horizontal Size for Window 1 Low Byte- 0x1C2	297
OSG Original Horizontal Size for Window 1 High Byte - 0x1C3	297
OSG Bitmap Buffer Horizontal Size Low Byte - 0x1CC.....	297
OSG Bitmap Buffer Horizontal Size High Byte - 0x1CD	298
OSG Bitmap Buffer Start Address Low Byte - 0x1CE.....	298
OSG Bitmap Buffer Start Address Middle Byte - 0x1CF	298
OSG Bitmap Buffer Start Address High Byte - 0x1D0.....	298
OSD for Display Path.....	299
Introduction	299
Features	299
Font and Picture Library.....	299
Font	299
Picture	300
Display Information.....	301
Channel Number	301
Channel Picture.....	301
Date and Time	302
Title	302
SRAM Allocation	302
Font and Picture SRAM	302
Display SRAM	303
Registers Table	305
Registers Description.....	307
OSD Control Register - 0x180	307
OSD Mode Register - 0x181	307
OSD Font Size Register - 0x182.....	308
OSD Channel Number Horizontal Position Low Byte Register - 0x183	309
OSD Channel Number Horizontal Position High Byte Register - 0x184.....	309
OSD Channel Number Vertical Position Low Byte Register - 0x185	309
OSD Channel Number Horizontal Position High Byte Register - 0x186.....	309
OSD Channel Picture Horizontal Position Low Byte Register - 0x187	309
OSD Channel Picture Horizontal Position High Byte Register - 0x188	309
OSD Channel Picture Vertical Position Low Byte Register - 0x189.....	309
OSD Channel Picture Horizontal Position High Byte Register - 0x18A	310
OSD Time and Date Horizontal Position Low Byte Register - 0x18B	310
OSD Time and Date Horizontal Position High Byte Register - 0x18C	310
OSD Time and Date Vertical Position Low Byte Register - 0x18D.....	310
OSD Time and Date Horizontal Position High Byte Register - 0x18E.....	310
OSD Title Horizontal Position Low Byte Register - 0x18F.....	310
OSD Title Horizontal Position High Byte Register - 0x190.....	310
OSD Title Vertical Position Low Byte Register - 0x191.....	311
OSD Title Horizontal Position High Byte Register - 0x192.....	311
OSD Font Red Color 1 Register - 0x193	311
OSD Font Green Color 1 Register - 0x194.....	311
OSD Font Blue Color 1 Register - 0x195.....	311
OSD Font Red Color 2 Register - 0x196	311
OSD Font Green Color 2 Register - 0x197	311
OSD Font Blue Color 2 Register - 0x198.....	312
OSD Font Red Color 3 Register - 0x199	312

OSD Font Green Color 3 Register – 0x19A.....	312
OSD Font Blue Color 3 Register – 0x19B	312
OSD Picture Red Color 0 Register – 0x19C.....	312
OSD Picture Green Color 0 Register – 0x19D.....	312
OSD Picture Blue Color 0 Register – 0x19E.....	312
OSD Picture Red Color 1 Register – 0x19F.....	313
OSD Picture Green Color 1 Register – 0x1A0.....	313
OSD Picture Blue Color 1 Register – 0x1A1.....	313
OSD Picture Red Color 2 Register – 0x1A2.....	313
OSD Picture Green Color 2 Register – 0x1A3.....	313
OSD Picture Blue Color 2 Register – 0x1A4.....	313
OSD Picture Red Color 3 Register – 0x1A5.....	313
OSD Picture Green Color 3 Register – 0x1A6.....	314
OSD Picture Blue Color 3 Register – 0x1A7.....	314
OSD Font and Picture RAM Address Low Byte Register – 0x1A8.....	314
OSD Font and Picture RAM Address High Byte Register – 0x1A9.....	314
OSD Font and Picture RAM Data Low Byte Register – 0x1AA.....	314
OSD Font and Picture RAM Data High Byte Register – 0x1AB.....	314
OSD Display RAM Address Register – 0x1AC.....	315
OSD Display RAM Address Register – 0x1AD.....	315
OSD Display RAM Data Register – 0x1AE.....	315
Registers Description.....	316
OSD Control Register – 0x180.....	316
OSD Mode Register – 0x181.....	316
OSD Font Size Register – 0x182.....	317
OSD Channel Number Horizontal Position Low Byte Register – 0x183.....	318
OSD Channel Number Horizontal Position High Byte Register – 0x184.....	318
Osd channel Number Vertical Position Low Byte Register – 0x185.....	318
Osd channel Number Horizontal Position High Byte Register – 0x186.....	318
Osd channel Picture Horizontal Position Low Byte Register – 0x187.....	318
Osd channel Picture Horizontal Position High Byte Register – 0x188.....	318
Osd channel Picture Vertical Position Low Byte Register – 0x189.....	319
Osd channel Picture Horizontal Position High Byte Register – 0x18A.....	319
OSD Time and Date Horizontal Position Low Byte Register – 0x18B.....	319
OSD Time and Date Horizontal Position High Byte Register – 0x18C.....	319
OSD Time and Date Vertical Position Low Byte Register – 0x18D.....	319
OSD Time and Date Horizontal Position High Byte Register – 0x18E.....	319
OSD Title Horizontal Position Low Byte Register – 0x18F.....	319
OSD Title Horizontal Position High Byte Register – 0x190.....	320
OSD Title Vertical Position Low Byte Register – 0x191.....	320
OSD Title Horizontal Position High Byte Register – 0x192.....	320
OSD Font Red Color 1 Register – 0x193.....	320
OSD Font Green Color 1 Register – 0x194.....	320
OSD Font Blue Color 1 Register – 0x195.....	320
OSD Font Red Color 2 Register – 0x196.....	320
OSD Font Green Color 2 Register – 0x197.....	321
OSD Font Blue Color 2 Register – 0x198.....	321
OSD Font Red Color 3 Register – 0x199.....	321
OSD Font Green Color 3 Register – 0x19A.....	321
OSD Font Blue Color 3 Register – 0x19B.....	321
OSD Picture Red Color 0 Register – 0x19C.....	321
OSD Picture Green Color 0 Register – 0x19D.....	321
OSD Picture Blue Color 0 Register – 0x19E.....	322
OSD Picture Red Color 1 Register – 0x19F.....	322
OSD Picture Green Color 1 Register – 0x1A0.....	322
OSD Picture Blue Color 1 Register – 0x1A1.....	322
OSD Picture Red Color 2 Register – 0x1A2.....	322

OSD Picture Green Color 2 Register – 0x1A3	322
OSD Picture Blue Color 2 Register – 0x1A4	322
OSD Picture Red Color 3 Register – 0x1A5	323
OSD Picture Green Color 3 Register – 0x1A6	323
OSD Picture Blue Color 3 Register – 0x1A7	323
OSD Font and Picture RAM Address Low Byte Register – 0x1A8	323
OSD Font and Picture RAM Address High Byte Register – 0x1A9	323
OSD Font and Picture RAM Data Low Byte Register – 0x1AA	323
OSD Font and Picture RAM Data High Byte Register – 0x1AB	324
OSD Display RAM Address Register – 0x1AC	324
OSD Display RAM Address Register – 0x1AD	324
OSD Display RAM Data Register – 0x1AE	324
Dualview Display Controller Unit	325
Introduction	325
Features	325
Dual Monitor Controller Architecture	325
Memory Diagram	325
Frame Data Synchronization	326
Dual Monitor Controller Block Diagram	327
Memory Interface	327
FIFO Interface	327
HV Timing Control	327
Down Scaler	328
Line Buffer Control	328
TV Encoder	329
OSD Control	329
Clock setting for dual monitor	330
Theory of Operation	330
TV Encoder Setting	331
Register Table	332
Registers	338
Dual Monitor Horizontal Total Low Byte Register – 0x700	338
Dual Monitor Horizontal Total High Byte Register – 0x701	338
Dual Monitor Vertical Total Low Byte Register – 0x702	338
Dual Monitor Vertical Total High Byte Register – 0x703	338
Dual Monitor Horizontal Width Low Byte Register – 0x704	338
Dual Monitor Horizontal Width High Byte Register – 0x705	338
Dual Monitor Vertical Height Low Byte Register – 0x706	339
Dual Monitor Vertical Height High Byte Register – 0x707	339
Dual Monitor Hsync Front Porch Low Byte Register – 0x708	339
Dual Monitor Hsync Front Porch High Byte Register – 0x709	339
Dual Monitor Vsync Front Porch Register – 0x70A	339
Dual Monitor Hsync Width Register – 0x70B	339
Dual Monitor Vsync Width Register – 0x70C	339
Dual Monitor Control Register – 0x70D	340
Dual Monitor Target Width for Down Scaler Low Byte Register – 0x70E	340
Dual Monitor Target Width for Down Scaler High Byte Register – 0x70F	340
Dual Monitor Target Height for Down Scaler Low Byte Register – 0x710	340
Dual Monitor Target Height for Down Scaler High Byte Register – 0x711	340
Dual Monitor Mode Register – 0x712	341
Dual Monitor Horizontal Start Low Byte Register – 0x713	341
Dual Monitor Vertical Start Low Byte Register – 0x714	341
Dual Monitor HSTART and VSTART High Byte Register – 0x715	341
Dual Monitor Down Scaler Source Width Low Byte Register – 0x716	341
Dual Monitor Down Scaler Source Width High Byte Register – 0x717	342
Dual Monitor Down Scaler Source Height Low Byte Register – 0x718	342

Dual Monitor Down Scaler Source Height High Byte Register – 0x719.....	342
Dual Monitor TV Encoder Control Register 1 – 0x71A.....	342
Dual Monitor TV Encoder Control Register 2 – 0x71B.....	343
Dual Monitor TV Encoder Control Register 3 – 0x71C.....	343
Dual Monitor TV Encoder Pixel Delay Low Byte Register – 0x71D.....	344
Dual Monitor TV Encoder Pixel Delay High Byte Register – 0x71E.....	344
Dual Monitor TV Encoder Line Delay Register – 0x71F.....	344
Dual Monitor TV Encoder Line Offset Register – 0x720.....	344
Dual Monitor TV Encoder Pixel Offset Register – 0x721.....	344
Dual Monitor TV Encoder Control Register 4 – 0x722.....	344
Dual Monitor TV Encoder Control Register 5 – 0x723.....	345
Dual Monitor Control Register – 0x724.....	345
Dual Monitor DAC Power Down Register – 0x725.....	345
Dual Monitor Mouse Update Enable Register – 0x726.....	345
Dual Monitor Down Scaler Horizontal Blank Register – 0x727.....	345
Dual Monitor Boundary Channel Enable Register 1 – 0x728.....	346
Dual Monitor Boundary Channel Enable Register 2 – 0x729.....	346
Dual Monitor Boundary Channel Enable Register 3 – 0x72A.....	346
Dual Monitor Boundary Channel Enable Register 4 – 0x72B.....	346
Dual Monitor Red Color for No Video Channel – 0x72C.....	346
Dual Monitor Green Color for No Video Channel – 0x72D.....	346
Dual Monitor Blue Color for No Video Channel – 0x72E.....	346
Dual Monitor Mouse Index Register – 0x72F.....	347
Dual Monitor Simple OSD Register – 0x730 to 0x75E.....	347
Dual Monitor Horizontal Display Enable Control Register – 0x75F.....	347
Dual Monitor Background Red Color Register – 0x760.....	347
Dual Monitor Background Green Color Register – 0x761.....	347
Dual Monitor Background Blue Color Register – 0x762.....	347
Dual Monitor Control Register – 0x763.....	347
Dual Monitor Boundary Red Color Register – 0x764.....	348
Dual Monitor Boundary Green Color Register – 0x765.....	348
Dual Monitor Boundary Blue Color Register – 0x766.....	348
Dual Monitor Vertical Total Window Register – 0x767.....	348
Dual Monitor Vertical Total Adjust Mode Register – 0x768.....	348
Dual Monitor Vertical Total from Input Video Low Byte Register – 0x769.....	348
Dual Monitor Vertical Total from Input Video High Byte Register – 0x76A.....	348
Dual Monitor Vertical Total after Adjustment Byte Register – 0x76B.....	348
Dual Monitor Vertical Total after Adjustment High Register – 0x76C.....	349
Dual Monitor Single Box Register – 0x76D to 0x7AB.....	349
Dual Monitor Mouse Register – 0x7AC to 0x7BD.....	349
Horizontal Down Scaler Factor Low Byte Register – 0x7BE.....	349
Horizontal Down Scale Factor High Byte Register – 0x7BF.....	349
Vertical Down Scale Factor Low Byte Register – 0x7C0.....	349
Vertical Down Scaler Factor High Byte Register – 0x7C1.....	349
Position Down Scaler Enable Control Register – 0x7C2.....	349
OSD Blink Rate Register – 0x7C3.....	350
Dual Monitor OSG Register – 0x7C4 to 0x7F5.....	350
Dual Monitor Digital R Gain Register – 0x7F6.....	350
Dual Monitor Digital G Gain Register – 0x7F7.....	350
Dual Monitor Digital B Gain Register – 0x7F8.....	350
Dual Monitor R Offset Register – 0x7F9.....	350
Dual Monitor G Offset Register – 0x7FA.....	350
Dual Monitor B Offset Register – 0x7FB.....	351
DMA Controller (DMAC).....	352
Overview.....	352
Features.....	352

Theory of Operation.....	352
DMA Engine	352
DRAM interface	353
EXTERNAL DMA DREQ/DACK PROTOCOL	353
Basic DMA Timing	353
Examples	355
Register Table	357
Register Definition	358
Display DRAM Source Vertical Position LSB Register – 0x230	358
Display DRAM Source Vertical Position MSB Register – 0x231	358
Display DRAM Destination Vertical Position LSB Register – 0x232	358
Display DRAM Destination Vertical Position MSB Register – 0x233	358
Display DRAM Vertical Transfer Size LSB Register – 0x234	358
Display DRAM Vertical Transfer Size MSB Register – 0x235	358
Display DRAM Source Horizontal Position LSB Register – 0x236	358
Display DRAM Source Horizontal Position MSB Register – 0x237	358
Display DRAM Destination Horizontal Position LSB Register – 0x238	359
Display DRAM Destination Horizontal Position MSB Register – 0x239	359
Display DRAM Horizontal Transfer Size LSB Register – 0x23a	359
Display DRAM Horizontal Transfer Size MSB Register – 0x23b	359
Display DRAM DMA Enable Register – 0x23c	359
Host DMA Destination Vertical Position LSB Register – 0x240	359
Host DMA Destination Vertical Position MSB Register – 0x241	359
Host DMA Vertical Transfer Size LSB Register – 0x242	359
Host DMA Vertical Transfer Size MSB Register – 0x243	359
Host DMA Destination Horizontal Position LSB Register – 0x244	359
Host DMA Destination Horizontal Position MSB Register – 0x245	360
Host DMA Horizontal Transfer Size Register LSB – 0x246	360
Host DMA Control Register – 0x247	360
Host DMA Enable Register – 0x248	360
Host DMA Transfer Mode Control Register – 0x249	360
Host DMA Status Register – 0x24a	361
OSG Total Transfer Size LSB Register 1 – 0x24b	361
OSG Total Transfer Size LSB Register 2 – 0x24c	361
OSG Total Transfer Size LSB Register 3 – 0x24d	361
OSG Total Transfer Size MSB Register – 0x24e	361
Host DMA Write Data – 0x25e, 0x260, 0x262, 0x264	361
Host DMA Display Pitch LSB Register – 0x268	362
Host DMA Display Pitch MSB Register – 0x269	362
Host DMA Start Address LSB Register 1 – 0x26a	362
Host DMA Start Address LSB Register 2 – 0x26b	362
Host DMA Start Address MSB Register – 0x26c	362
Record DRAM Source Vertical Position LSB Register – 0x250	362
Record DRAM Source Vertical Position MSB Register – 0x251	362
Record DRAM Destination Vertical Position LSB Register – 0x252	362
Record DRAM Destination Vertical Position MSB Register – 0x253	363
Record DRAM Vertical Transfer Size LSB Register – 0x254	363
Record DRAM Vertical Transfer Size MSB Register – 0x255	363
Record DRAM Source Horizontal Position LSB Register – 0x256	363
Record DRAM Source Horizontal Position MSB Register – 0x257	363
Record DRAM Destination Horizontal Position LSB Register – 0x258	363
Record DRAM Destination Horizontal Position MSB Register – 0x259	363
Record DRAM Horizontal Transfer Size LSB Register – 0x25a	363
Record DRAM Horizontal Transfer Size MSB Register – 0x25b	363
Record DRAM DMA Enable Register – 0x25c	364
Recording and Output unit	365

Introduction	365
Functional Description.....	365
Picture Format Control	366
Frame Rate Control Unit.....	366
Record Channels Arrangement Example	366
8 D1 channel frame interleaved real time output.....	366
16 D1 channel field interleaved real time output	367
16 channel mixed format real time output	367
16 D1 channel frame interleaved real time output	367
SPOT monitor memory space	368
Record Postions in detail.....	369
SPOT write buffer	369
Recording Unit	370
Introduction.....	370
Record Out Format Control	370
D1 Video Frame Data Arrange.....	371
CIF Video Frame Data arrange	371
16-Bit Video Frame Data arrange	371
Record output Method	371
Multi-mode Format Control	371
Recording format example	372
Record out channel output example	373
Record port misc. items.....	374
Special Output Format	375
Record Port Capability Chart	376
Multi-mode Record Port Programming Example	376
Output Port	377
Introduction.....	377
8-bit mode	379
16-bit mode	380
16-bit component mode.....	380
Field Switching mode.....	382
32 buffer mode	382
Output Pin Source Control	382
Field Switching Quad mode	383
Synchronization mode	383
Multi-mode	383
Conclusion	384
Record out AC timing.....	384
Register Table.....	385
Registers Description.....	391
Recording Buffer 1 Control Register A - 0xC00	391
Recording Buffer 1 Control Register B - 0xC10	391
Record Port 1 Control Register - 0xC20.....	392
Record Port 1 Source Control Register A - 0xC21.....	392
Record Port 1 Source Control Register B - 0xC22.....	392
Record Port 1 Custom Horizontal Control Register - 0xC23.....	392
Record Port 1 Custom Vertical Control Register - 0xC24	392
Record Port 2 Control Register - 0xC25.....	393
Record Port 2 Source Control Register A - 0xC26.....	393
Record Port 2 Source Control Register B - 0xC27.....	393
Record Port 2 Custom Horizontal Control Register - 0xC28.....	393
Record Port 2 Custom Vertical Control Register - 0xC29	393
Record Port 3 Control Register - 0xC2A.....	394
Record Port 3 Source Control Register A - 0xC2B.....	394
Record Port 3 Source Control Register B - 0xC2C.....	394
Record Port 3 Custom Horizontal Control Register - 0xC2D.....	394

Record Port 3 Custom Vertical Control Register – 0xC2E.....	394
Record Port 4 Control Register – 0xC2F.....	395
Record Port 4 Source Control Register A – 0xC30.....	395
Record Port 4 Source Control Register B – 0xC31.....	395
Record Port 4 Custom Horizontal Control Register – 0xC32.....	395
Record Port 4 Custom Vertical Control Register – 0xC33.....	395
Record Port 5 Control Register – 0xC34.....	396
Record Port 5 Source Control Address Register – 0xC35.....	396
Record Port 5 Source Control Data Register – 0xC36.....	396
Record Port 5 Source Number Register – 0xC37.....	396
Record Port 5 Custom Horizontal Control Register – 0xC38.....	396
Record Port 5 Custom Vertical Control Register – 0xC39.....	396
Record Port 6 Control Register – 0xC3A.....	397
Record Port 6 Source Control Address Register – 0xC3B.....	397
Record Port 6 Source Control Data Register – 0xC3C.....	397
Record Port 6 Source Number Register – 0xC3D.....	397
Record Port 6 Custom Horizontal Control Register – 0xC3E.....	397
Record Port 6 Custom Vertical Control Register – 0xC3F.....	397
Record Port 7 Control Register – 0xC40.....	398
Record Port 7 Source Control Address Register – 0xC41.....	398
Record Port 7 Source Control Data Register – 0xC42.....	398
Record Port 7 Source Number Register – 0xC43.....	398
Record Port 7 Custom Horizontal Control Register – 0xC44.....	398
Record Port 7 Custom Vertical Control Register – 0xC45.....	398
Record Port 8 Control Register – 0xC46.....	399
Record Port 8 Source Control Address Register – 0xC47.....	399
Record Port 8 Source Control Data Register – 0xC48.....	399
Record Port 8 Source Number Register – 0xC49.....	399
Record Port 8 Custom Horizontal Control Register – 0xC4A.....	399
Record Port 8 Custom Vertical Control Register – 0xC4B.....	399
Record Port 1-4 Source Control Register – 0xC4C.....	400
Record Port Operating Mode Select Register – 0xC4D.....	400
Output Pin Set 1 Control Register – 0xC4E.....	401
Output Pin Set 2 Control Register – 0xC4F.....	401
Output Pin Set 3 Control Register – 0xC50.....	402
Output Pin Set 4 Control Register – 0xC51.....	403
Network Port Control Register – 0xC52.....	403
Network Port Control Address Register – 0xC53.....	404
Network Port Control Data Register – 0xC54.....	404
Network Port Source Number Register – 0xC55.....	404
MISC. Control Register 1 – 0xC56.....	404
4D1 and QUAD 2 nd Write Horizontal Margin Register – 0xC57.....	404
MISC. Control Register 2 – 0xC58.....	405
MISC. Control Register 3 – 0xC59.....	405
Record HDE Control Register – 0xC5A.....	405
Record VDE Control Register – 0xC5B.....	405
Record Buffer Freeze Control Register A – 0xC64.....	405
Record Buffer Freeze Control Register B – 0xC65.....	405
SPOT Buffer Freeze Control Register A – 0xC66.....	406
SPOT Buffer Freeze Control Register B – 0xC67.....	406
Custom Clock Control Register – 0xC68.....	406
Interlaced Frame Output Mode Control Register – 0xC69.....	406
‘wr_page’ Reference Selection Control Register A(Write buffer Index) – 0xC6A.....	406
‘wr_page’ Reference Selection Control Register B(Read Port Index) – 0xC6B.....	407
New FRSC Control Register B – 0xC6C.....	407
PB Ignore Bit Control Register – 0xC6D.....	408
PB Ignore Value Register 1 – 0xC6E.....	408

PB Ignore Value Register 2 – 0xC6F.....	408
Background Color for Cb – 0xC70.....	408
Background Color for Cr – 0xC71.....	409
Background Color for Y – 0xC72.....	409
Background On/off Control 1 for Record Write Buffer – 0xC73.....	409
Background On/off Control 2 for Record Write Buffer – 0xC74.....	409
Background On/off Control 1 for SPOT Write Buffer – 0xC75.....	409
Background On/off Control 2 for SPOT Write Buffer – 0xC76.....	409
New Non-real Time Field Switching Mode for Port 5 ~ Port 9 – 0xC77.....	409
New Field Switching Mode Field Select for Port 5 ~ Port 9 – 0xC78.....	410
Field Interleaved Read Mode with 4 Frames – 0xC79.....	410
New Non-real Time Field Switching Mode for Port 5 ~ Port 9 – 0xC7A.....	410
SPOT Recording Buffer 1 Control Register A – 0xC90.....	410
SPOT Recording Buffer 1 Control Register B – 0xCA0.....	411
Background Buffer Indication Register 1 – 0xCC8.....	411
Background Buffer Indication Register 2 – 0xCC9.....	411
Second Record Buffer DRAM Control Register 1 – 0xCCA.....	411
Second Record Buffer DRAM Control Register 2 – 0xCCB.....	412
Second SPOT DRAM Buffer Control Register 1 – 0xCCC.....	412
Second SPOT DRAM Buffer Control Register 2 – 0xCCD.....	412
Record Buffer Alternate Source Control Register 1 – 0xCCE.....	412
Record Buffer Alternate Source Control Register 2 – 0xCCF.....	412
Record Buffer Horizontal Offset Control Register – 0xCD0-DF.....	412
Record Buffer Vertical Offset Control Register – 0xCE0-EF.....	413
Special Component Record Mode Register – 0xCF0.....	413
Record Buffer Field Switching Record Mode Register 1 – 0xCF1.....	413
Record Buffer Field Switching Record Mode Register 2 – 0xCF2.....	413
Record Buffer Field Switching Record Mode Field Select Register 1 – 0xCF3.....	414
Record Buffer Field Switching Record Mode Field Select Register 2 – 0xCF4.....	414
Output Pin Set Source 2 Control Register A – 0xCF5.....	414
Output Pin Set Source 2 Control Register B – 0xCF6.....	415
Frame Rate Controller Update Register – 0xCF7.....	415
SPOT Buffer Field Switching Record Mode Register 1 – 0xCF8.....	415
SPOT Buffer Field Switching Record Mode Register 2 – 0xCF9.....	416
SPOT Buffer Field Switching Record Mode Field Select Register 1 – 0xCFA.....	416
SPOT Buffer Field Switching Record Mode Field Select Register 2 – 0xCFB.....	416
Write Buffer Control Register – 0xCFC.....	416
New FRSC Control Register A – 0xCFD.....	417
New Write Buffer Mapping Control Register – 0xCFE.....	417
Motion Decton Unit.....	418
Introduction.....	418
Motion Data Extraction.....	418
Mask and Detection Region Selection.....	419
Sensitivity Control.....	420
Level Sensitivity.....	420
Spatial Sensitivity.....	420
Temporal Sensitivity.....	420
Velocity Control.....	420
Blind Detection.....	422
Night Detection.....	422
Register Table.....	424
Registers Description.....	426
Motion Detection Cell Line 0 Mask Register 1 – 0x800.....	426
Motion Detection Cell Line 0 Mask Register 2 – 0x801.....	426
Motion Detection Cell Line 1 Mask Register 1 – 0x802.....	426
Motion Detection Cell Line 1 Mask Register 2 – 0x803.....	426

Motion Detection Cell Line 2 Mask Register 1 - 0x804.....	426
Motion Detection Cell Line 2 Mask Register 2 - 0x805.....	426
Motion Detection Cell Line 3 Mask Register 1 - 0x806.....	426
Motion Detection Cell Line 3 Mask Register 2 - 0x807.....	426
Motion Detection Cell Line 4 Mask Register 1 - 0x808.....	426
Motion Detection Cell Line 4 Mask Register 2 - 0x809.....	427
Motion Detection Cell Line 5 Mask Register 1 - 0x80A.....	427
Motion Detection Cell Line 5 Mask Register 2 - 0x80B.....	427
Motion Detection Cell Line 6 Mask Register 1 - 0x80C.....	427
Motion Detection Cell Line 6 Mask Register 2 - 0x80D.....	427
Motion Detection Cell Line 7 Mask Register 1 - 0x80E.....	427
Motion Detection Cell Line 7 Mask Register 2 - 0x80F.....	427
Motion Detection Cell Line 8 Mask Register 1 - 0x810.....	427
Motion Detection Cell Line 8 Mask Register 2 - 0x811.....	427
Motion Detection Cell Line 9 Mask Register 1 - 0x812.....	427
Motion Detection Cell Line 9 Mask Register 2 - 0x813.....	428
Motion Detection Cell Line 10 Mask Register 1 - 0x814.....	428
Motion Detection Cell Line 10 Mask Register 2 - 0x815.....	428
Motion Detection Cell Line 11 Mask Register 1 - 0x816.....	428
Motion Detection Cell Line 11 Mask Register 2 - 0x817.....	428
Motion Detection Control Register 1 - 0x818.....	428
Motion Detection Control Register 2 - 0x819.....	428
Motion Detection Control Register 3 - 0x81A.....	428
Motion Detection Control Register 4 - 0x81B.....	429
Motion Detection Control Register 5 - 0x81E.....	429
Motion Detection Control Register 6 - 0x81F.....	429
Motion Detection Cell Line 0 Result Register 1 - 0x820.....	429
Motion Detection Cell Line 0 Result Register 2 - 0x821.....	429
Motion Detection Cell Line 1 Result Register 1 - 0x822.....	430
Motion Detection Cell Line 1 Result Register 2 - 0x823.....	430
Motion Detection Cell Line 2 Result Register 1 - 0x824.....	430
Motion Detection Cell Line 2 Result Register 2 - 0x825.....	430
Motion Detection Cell Line 3 Result Register 1 - 0x826.....	430
Motion Detection Cell Line 3 Result Register 2 - 0x827.....	430
Motion Detection Cell Line 4 Result Register 1 - 0x828.....	430
Motion Detection Cell Line 4 Result Register 2 - 0x829.....	430
Motion Detection Cell Line 5 Result Register 1 - 0x82A.....	430
Motion Detection Cell Line 5 Result Register 2 - 0x82B.....	430
Motion Detection Cell Line 6 Result Register 1 - 0x82C.....	431
Motion Detection Cell Line 6 Result Register 2 - 0x82D.....	431
Motion Detection Cell Line 7 Result Register 1 - 0x82E.....	431
Motion Detection Cell Line 7 Result Register 2 - 0x82F.....	431
Motion Detection Cell Line 8 Result Register 1 - 0x830.....	431
Motion Detection Cell Line 8 Result Register 2 - 0x831.....	431
Motion Detection Cell Line 9 Result Register 1 - 0x832.....	431
Motion Detection Cell Line 9 Result Register 2 - 0x833.....	431
Motion Detection Cell Line 10 Result Register 1 - 0x834.....	431
Motion Detection Cell Line 10 Result Register 2 - 0x835.....	431
Motion Detection Cell Line 11 Result Register 1 - 0x836.....	432
Motion Detection Cell Line 11 Result Register 2 - 0x837.....	432
Channel ID Encoder Unit.....	433
Channel ID Encoder.....	433
Channel ID Definition.....	433
Auto Channel ID.....	433
Detection Channel ID.....	434
User Channel ID.....	435

Channel ID Output Method	435
Digital Channel ID	436
Analog Channel ID	438
Channel ID in Active Region	438
Registers Table	440
Registers Description.....	446
PB1 Channel ID Enc Misc Register – 0xD00	446
PB1 Channel ID Enc Enable Register – 0xD01	446
PB1 Channel ID Enc Horizontal Offset Register – 0xD02	447
PB1 Channel ID Enc High Value Register – 0xD03	447
PB1 Channel ID Enc Low Value Register – 0xD04	447
PB1 Odd Field Vertical Line Offset Register – 0xD05.....	447
PB1 Channel ID Enc Man0 LSB Register – 0xD06.....	447
PB1 Channel ID Enc Man0 MSB Register – 0xD07.....	448
PB1 Channel ID Enc Man1 LSB Register – 0xD08.....	448
PB1 Channel ID Enc Man1 SB Register – 0xD09	448
PB1 Channel ID Enc Man2 LSB Register – 0xD0A.....	448
PB1 Channel ID Enc Man2 MSB Register – 0xD0B.....	448
PB1 Channel ID Enc Man3 LSB Register – 0xD0C.....	448
PB1 Channel ID Enc Man3 MSB Register – 0xD0D	448
PB1 Channel ID Enc Man4 LSB Register – 0xD0E	449
PB1 Channel ID Enc Man4 MSB Register – 0xD0F.....	449
PB1 Channel ID Enc Man5 LSB Register – 0xD10.....	449
PB1 Channel ID Enc Man5 MSB Register – 0xD11.....	449
PB1 Even Field Vertical Offset Register – 0xD90.....	449
Active Area Channel ID Enable Register 1 – 0xDAB	450
Active Area Channel ID Enable Register 2 – 0xDAC	450
Active Area Channel ID in First Frame Register 1 – 0xDAD	450
Active Area Channel ID in First Frame Register 2 – 0xDAE	450
Active Area Channel ID Data Register – 0xDAF.....	450
Motion Channel Selection Register – 0xDB0	451
Field selection Register – 0xDB5	451
Field selection Register – 0xDB6	451
OSD for Recording Path.....	452
Introduction	452
Features	452
Description	452
Layers	452
Resolutions	452
Timing Diagram	454
Vertical timing	454
Horizontal timing.....	454
Font Composition	455
Display Channel Information	456
Date and Time	456
Title	456
Status	457
SRAM Allocation	457
Font SRAM	457
Display SRAM	458
Privacy Windows.....	458
Introduction.....	458
Masking Effect.....	458
Mosaic Effect	459
Registers Table	460
Registers Description.....	464

ROSD Enable Register – 0xE00.....	464
ROSD Time and Date Enable Register – 0xE01	464
ROSD Title Enable Register – 0xE02	464
ROSD Status Enable Register – 0xE03	465
ROSD Boundary Enable Register – 0xE04.....	465
ROSD Background Enable Register – 0xE05	465
ROSD Mix Control Enable Register – 0xE06.....	466
ROSD Boundary Width Register – 0xE07	466
ROSD Font Size Register – 0xE08.....	466
ROSD Time Horizontal Postion for Full Mode Low Byte Register – 0xE09.....	467
ROSD Time Horizontal Postion for Full Mode High Byte Register – 0xE0A.....	467
ROSD Time Horizontal Left Postion for Half Mode Low Byte Register – 0xE0B.....	467
ROSD Time Horizontal Left Postion for Half Mode High Byte Register – 0xE0C.....	467
ROSD Time Horizontal Right Postion for Half Mode Low Byte Register – 0xE0D	467
ROSD Time Horizontal Right Postion for Half Mode High Byte Register – 0xE0E.....	468
ROSD Time Vertical Postion for Full Mode Low Byte Register – 0xE0F.....	468
ROSD Time Vertical Postion for Full Mode High Byte Register – 0xE10.....	468
ROSD Time Vertical Top Postion for Half Mode Low Byte Register – 0xE11.....	468
ROSD Time Vertical Top Postion for Half Mode High Byte Register – 0xE12	468
ROSD Time Vertical Bottom Postion for Half Mode Low Byte Register – 0xE13	468
ROSD Time Vertical Bottom Postion for Half Mode High Byte Register – 0xE14	468
ROSD Title Horizontal Postion for Full Mode Low Byte Register – 0xE15	469
ROSD Title Horizontal Postion for Full Mode High Byte Register – 0xE16.....	469
ROSD Title Horizontal Left Postion for Half Mode Low Byte Register – 0xE17	469
ROSD Title Horizontal Left Postion for Half Mode High Byte Register – 0xE18	469
ROSD Title Horizontal Right Postion for Half Mode Low Byte Register – 0xE19.....	469
ROSD Title Horizontal Right Postion for Half Mode High Byte Register – 0xE1A.....	469
ROSD Title Vertical Postion for Full Mode Low Byte Register – 0xE1B.....	469
ROSD Title Vertical Postion for Full Mode High Byte Register – 0xE1C.....	470
ROSD Title Vertical Top Postion for Half Mode Low Byte Register – 0xE1D	470
ROSD Title Vertical Top Postion for Half Mode High Byte Register – 0xE1E.....	470
ROSD Title Vertical Bottom Postion for Half Mode Low Byte Register – 0xE1F.....	470
ROSD Title Vertical Bottom Postion for Half Mode High Byte Register – 0xE20.....	470
ROSD Status Horizontal Postion for Full Mode Low Byte Register – 0xE21	470
ROSD Status Horizontal Postion for Full Mode High Byte Register – 0xE22	470
ROSD Status Horizontal Left Postion for Half Mode Low Byte Register – 0xE23	471
ROSD Status Horizontal Left Postion for Half Mode High Byte Register – 0xE24	471
ROSD Status Horizontal Right Postion for Half Mode Low Byte Register – 0xE25.....	471
ROSD Status Horizontal Right Postion for Half Mode High Byte Register – 0xE26.....	471
ROSD Status Vertical Postion for Full Mode Low Byte Register – 0xE27.....	471
ROSD Status Vertical Postion for Full Mode High Byte Register – 0xE28.....	471
ROSD Status Vertical Top Postion for Half Mode Low Byte Register – 0xE29.....	471
ROSD Status Vertical Top Postion for Half Mode High Byte Register – 0xE2A.....	472
ROSD Status Vertical Bottom Postion for Half Mode Low Byte Register – 0xE2B.....	472
ROSD Status Vertical Bottom Postion for Half Mode High Byte Register – 0xE2C.....	472
ROSD Font Y Color 1 Register – 0xE2D.....	472
ROSD Font Cb Color 1 Register – 0xE2E.....	472
ROSD Font Cr Color 1 Register – 0xE2F.....	472
ROSD Font Y Color 2 Register – 0xE30.....	472
ROSD Font Cb Color 2 Register – 0xE31	473
ROSD Font Cr Color 2 Register – 0xE32	473
ROSD Font Y Color 3 Register – 0xE33.....	473
ROSD Font Cb Color 3 Register – 0xE34	473
ROSD Font Cr Color 3 Register – 0xE35	473
ROSD Background Y Color Register – 0xE36.....	473
ROSD Background Cb Color Register – 0xE37	473
ROSD Background Cr Color Register – 0xE38	474

ROSD Boundary Y Color Register – 0xE39	474
ROSD Boundary Cb Color Register – 0xE3A.....	474
ROSD Boundary Cr Color Register – 0xE3B.....	474
ROSD Font RAM Address Low Byte Register – 0xE3C.....	474
ROSD Font RAM Address High Byte Register – 0xE3D.....	474
ROSD Font RAM Data Low Byte Register – 0xE3E.....	474
ROSD Font RAM Data High Byte Register – 0xE3F.....	475
ROSD Display RAM Address Register – 0xE40.....	475
ROSD Display RAM Address Register – 0xE41.....	475
ROSD Display RAM Data Register – 0xE42.....	475
ROSD Color Bar Enable Register – 0xE43.....	475
ROSD Enable for Port 9 Register – 0xE44.....	476
ROSD Colbar Vertical Black Bar Position Register – 0xE45	476
ROSD Field Switching Control Register – 0xE46.....	476
Privacy Window Overflow Register 1 – 0xE47	476
Privacy Window Overflow Register 2 – 0xE48.....	476
Privacy Window Shadow Set Control Register – 0xE4F	476
Privacy Window 1 Horizontal Start Register – 0xE50 – 0xE5F	477
Privacy Window 1 Vertical Start Register – 0xE60 – 0xE6F.....	477
Privacy Window 1 Control Register – 0xE70 – 0xE7F	477
Privacy Window 2 Horizontal Start Register – 0xE80 – 0xE8F	478
Privacy Window 2 Vertical Start Register – 0xE90 – 0xE9F.....	478
Privacy Window 2 Control Register – 0xEA0 – 0xEAF	479
Privacy Window 3 Horizontal Start Register – 0xEB0 – 0xEBF	479
Privacy Window 3 Vertical Start Register – 0xEC0 – 0xECF	479
Privacy Window 3 Control Register – 0xED0 – 0xEDF.....	480
Privacy Window 4 Horizontal Start Register – 0xDD0 – 0xDDF.....	480
Privacy Window 4 Vertical Start Register – 0xDE0 – 0xDEF	480
Privacy Window 4 Control Register – 0xDF0 – 0xDFF.....	481
SPOT Controller Unit.....	482
Introduction	482
Features	482
SPOT Controller Architecture.....	482
Memory access control.....	482
Frame Data Synchronization.....	482
SPOT Controller Block Diagram.....	483
Memory Interface.....	483
Rotation control	484
FIFO Interface	484
HV Timing Control	484
Down Scalar.....	485
LBUF Control	485
OSD, Background and Border control.....	485
TV Encoder	486
Theory of Operation	486
Registers Table	488
Registers	500
SPOT1 Control Register– 0xF00.....	500
SPOT1 Control Register– 0xF01.....	500
SPOT1 Control Register– 0xF02.....	500
SPOT1 Control Register– 0xF03.....	500
SPOT1 Control Register– 0xF04.....	500
SPOT1 Control Register– 0xF05.....	500
SPOT1 Control Register– 0xF06.....	500
SPOT1 Control Register– 0xF07.....	501
SPOT1 Control Register– 0xF08.....	501

SPOT1 Control Register – 0xF09.....	501
SPOT1 Control Register – 0xF0A.....	501
SPOT1 Control Register – 0xF0B	502
SPOT1 Control Register – 0xF0C.....	502
SPOT1 Control Register – 0xF0D	502
SPOT1 Control Register – 0xF0E.....	502
SPOT1 Control Register – 0xF0F.....	503
SPOT1 Control Register – 0xF10.....	503
SPOT1 Control Register – 0xF11.....	503
SPOT1 Control Register – 0xF12.....	503
SPOT1 Control Register – 0xF13.....	504
SPOT1 Control Register – 0xF14.....	504
SPOT1 Control Register – 0xF15.....	504
SPOT1 Control Register – 0xF16.....	504
SPOT1 Control Register – 0xF17.....	504
SPOT1 Control Register – 0xF18.....	505
SPOT1 Control Register – 0xF19.....	506
SPOT1 Control Register – 0xF1A.....	506
SPOT1 Control Register – 0xF1B	506
SPOT1 Control Register – 0xF1C.....	506
SPOT1 Control Register – 0xF1D	506
SPOT1 Control Register – 0xF1E.....	507
SPOT1 Control Register – 0xF1F.....	507
SPOT1 Control Register – 0xF20.....	507
SPOT Control Register – 0xF21	507
SPOT Control Register – 0xF22	508
SPOT Control Register – 0xF23	508
SPOT Control Register – 0xF24	508
SPOT Control Register – 0xF25	508
SPOT Control Register – 0xF26	508
SPOT Control Register – 0xF27	508
SPOT Control Register – 0xF28.....	509
SPOT Control Register – 0xF29.....	509
SPOT2 Control Register – 0xF2A.....	509
SPOT2 Control Register – 0xF2B	509
SPOT3 Control Register – 0xF2C.....	509
SPOT3 Control Register – 0xF2D	509
SPOT4 Control Register – 0xF2E.....	509
SPOT4 Control Register – 0xF2F.....	510
SPOT1 Control Register – 0xF30.....	510
SPOT1 Control Register – 0xF31.....	511
SPOT1 OSD Font Size Register – 0xF32	512
SPOT1 Osd channel Number Horizontal Position Low Byte Register – 0xF33	512
SPOT1 Osd channel Number Horizontal Position High Byte Register – 0xF34	512
SPOT1 Osd channel Number Vertical Position Low Byte Register – 0xF35.....	512
SPOT1 Osd channel Number Horizontal Position High Byte Register – 0xF36	513
SPOT1 Osd channel Picture Horizontal Position Low Byte Register – 0xF37	513
SPOT1 Osd channel Picture Horizontal Position High Byte Register – 0xF38.....	513
SPOT1 Osd channel Picture Vertical Position Low Byte Register – 0xF39.....	513
SPOT1 Osd channel Picture Horizontal Position High Byte Register – 0xF3A.....	514
SPOT1 OSD Time and Date Horizontal Position Low Byte Register – 0xF3B	514
SPOT1 OSD Time and Date Horizontal Position High Byte Register – 0xF3C.....	514
SPOT1 OSD Time and Date Vertical Position Low Byte Register – 0xF3D	514
SPOT1 OSD Time and Date Horizontal Position High Byte Register – 0xF3E.....	515
SPOT1 OSD Title Horizontal Position Low Byte Register – 0xF3F.....	515
SPOT1 OSD Title Horizontal Position High Byte Register – 0xF40	515
SPOT1 OSD Title Vertical Position Low Byte Register – 0xF41.....	515

SPOT1 OSD Title Horizontal Position High Byte Register – 0xF42	515
SPOT OSD Font Red Color 1 Register – 0xF43	515
SPOT OSD Font Green Color 1 Register – 0xF44	515
SPOT OSD Font Blue Color 1 Register – 0xF45	516
SPOT OSD Font Red Color 2 Register – 0xF46	516
SPOT OSD Font Green Color 2 Register – 0xF47	516
SPOT OSD Font Blue Color 2 Register – 0xF48	516
SPOT OSD Font Red Color 3 Register – 0xF49	516
SPOT OSD Font Green Color 3 Register – 0xF4A	516
SPOT OSD Font Blue Color 3 Register – 0xF4B	516
SPOT OSD Picture Red Color 0 Register – 0xF4C	517
SPOT OSD Picture Green Color 0 Register – 0xF4D	517
SPOT OSD Picture Blue Color 0 Register – 0xF4E	517
SPOT OSD Picture Red Color 1 Register – 0xF4F	517
SPOT OSD Picture Green Color 1 Register – 0xF50	517
SPOT OSD Picture Blue Color 1 Register – 0xF51	517
SPOT OSD Picture Red Color 2 Register – 0xF52	517
SPOT OSD Picture Green Color 2 Register – 0xF53	518
SPOT OSD Picture Blue Color 2 Register – 0xF54	518
SPOT OSD Picture Red Color 3 Register – 0xF55	518
SPOT OSD Picture Green Color 3 Register – 0xF56	518
SPOT OSD Picture Blue Color 3 Register – 0xF57	518
SPOT1 OSD Font and Picture RAM Address Low Byte Register – 0xF58	518
SPOT1 OSD Font and Picture RAM Address High Byte Register – 0xF59	518
SPOT1 OSD Font and Picture RAM Data Low Byte Register – 0xF5A	519
SPOT1 OSD Font and Picture RAM Data High Byte Register – 0xF5B	519
SPOT1 OSD Display RAM Address Register – 0xF5C	519
SPOT1 OSD Display RAM Data Register – 0xF5D	519
SPOT DISP_PITCH Register – 0xF5E	519
SPOT ADJUSTMENT ENABLE Register – 0xF5F	519
SPOT2 Control Register – 0xF60	520
SPOT2 Control Register – 0xF61	520
SPOT1 Control Register – 0xF62	520
SPOT2 Control Register – 0xF63	520
SPOT2 Control Register – 0xF64	520
SPOT2 Control Register – 0xF65	520
SPOT2 Control Register – 0xF66	521
SPOT2 Control Register – 0xF67	521
SPOT2 Control Register – 0xF68	521
SPOT2 Control Register – 0xF69	521
SPOT2 Control Register – 0xF6A	522
SPOT2 Control Register – 0xF6B	522
SPOT2 Control Register – 0xF6C	522
SPOT2 Control Register – 0xF6D	522
SPOT2 Control Register – 0xF6E	522
SPOT2 Control Register – 0xF6F	523
SPOT2 Control Register – 0xF70	523
SPOT2 Control Register – 0xF71	523
SPOT2 Control Register – 0xF72	523
SPOT2 Control Register – 0xF73	524
SPOT2 Control Register – 0xF74	524
SPOT2 Control Register – 0xF75	524
SPOT2 Control Register – 0xF76	524
SPOT2 Control Register – 0xF77	524
SPOT2 Control Register – 0xF78	525
SPOT2 Control Register – 0xF79	526
SPOT2 Control Register – 0xF7A	526

SPOT2 Control Register – 0xF7B	526
SPOT2 Control Register – 0xF7C.....	526
SPOT2 Control Register – 0xF7D	527
SPOT2 Control Register – 0xF7E.....	527
SPOT2 Control Register – 0xF7F.....	527
SPOT2 Control Register – 0xF80.....	527
SPOT2 Control Register – 0xF81	528
SPOT2 Control Register – 0xF82.....	528
SPOT2 OSD Font Size Register – 0xF83	529
SPOT2 OSD Time and Date Horizontal Position Low Byte Register – 0xF84.....	529
SPOT2 OSD Time and Date Horizontal Position High Byte Register – 0xF85.....	530
SPOT2 OSD Time and Date Vertical Position Low Byte Register – 0xF86	530
SPOT2 OSD Time and Date Vertical Position High Byte Register – 0xF87	530
SPOT2 OSD Title Horizontal Position Low Byte Register – 0xF88	530
SPOT2 OSD Title Horizontal Position High Byte Register – 0xF89	530
SPOT2 OSD Title Vertical Position Low Byte Register – 0xF8A.....	530
SPOT2 OSD Title Horizontal Position High Byte Register – 0xF8B	530
SPOT2 OSD Font and Picture RAM Address Low Byte Register – 0xF8C.....	531
SPOT2 OSD Font and Picture RAM Address High Byte Register – 0xF8D.....	531
SPOT2 OSD Font and Picture RAM Data Low Byte Register – 0xF8E.....	531
SPOT2 OSD Font and Picture RAM Data High Byte Register – 0xF8F	531
SPOT3 Control Register – 0xF90.....	531
SPOT3 Control Register – 0xF91.....	531
SPOT3 Control Register – 0xF92.....	532
SPOT3 Control Register – 0xF93.....	532
SPOT3 Control Register – 0xF94.....	532
SPOT3 Control Register – 0xF95.....	532
SPOT3 Control Register – 0xF96.....	532
SPOT3 Control Register – 0xF97.....	533
SPOT3 Control Register – 0xF98.....	533
SPOT3 Control Register – 0xF99	533
SPOT3 Control Register – 0xF9A.....	533
SPOT3 Control Register – 0xF9B	533
SPOT3 Control Register – 0xF9C.....	534
SPOT3 Control Register – 0xF9D	534
SPOT3 Control Register – 0xF9E.....	534
SPOT3 Control Register – 0xF9F	534
SPOT3 Control Register – 0xFA0.....	535
SPOT3 Control Register – 0xFA1.....	535
SPOT3 Control Register – 0xFA2.....	535
SPOT3 Control Register – 0xFA3.....	535
SPOT3 Control Register – 0xFA4.....	536
SPOT3 Control Register – 0xFA5.....	536
SPOT3 Control Register – 0xFA6.....	536
SPOT3 Control Register – 0xFA7.....	536
SPOT3 Control Register – 0xFA8	536
SPOT3 Control Register – 0xFA9	537
SPOT3 Control Register – 0xFAA	538
SPOT3 Control Register – 0xFAB	538
SPOT3 Control Register – 0xFAC.....	538
SPOT3 Control Register – 0xFAD	538
SPOT3 Control Register – 0xFAE.....	538
SPOT3 Control Register – 0xFAF.....	539
SPOT3 Control Register – 0xFB0	539
SPOT3 Control Register – 0xFB1	539
SPOT3 Control Register – 0xFB2	540
SPOT3 OSD Font Size Register – 0xFB3	541

SPOT3 OSD Time and Date Horizontal Position Low Byte Register – 0xFB4	541
SPOT3 OSD Time and Date Horizontal Position High Byte Register – 0xFB5.....	541
SPOT3 OSD Time and Date Vertical Position Low Byte Register – 0xFB6	541
SPOT3 OSD Time and Date Vertical Position High Byte Register – 0xFB7	542
SPOT3 OSD Title Horizontal Position Low Byte Register – 0xFB8	542
SPOT3 OSD Title Horizontal Position High Byte Register – 0xFB9	542
SPOT3 OSD Title Vertical Position Low Byte Register – 0xFBA.....	542
SPOT3 OSD Title Horizontal Position High Byte Register – 0xFBB	542
SPOT3 OSD Font and Picture RAM Address Low Byte Register – 0xFBC.....	542
SPOT3 OSD Font and Picture RAM Address High Byte Register – 0xFBD.....	542
SPOT3 OSD Font and Picture RAM Data Low Byte Register – 0xFBE.....	543
SPOT3 OSD Font and Picture RAM Data High Byte Register – 0xFBF	543
SPOT4 Control Register – 0xFC0.....	543
SPOT4 Control Register – 0xFC1.....	543
SPOT4 Control Register – 0xFC2.....	543
SPOT4 Control Register – 0xFC3.....	543
SPOT4 Control Register – 0xFC4.....	543
SPOT4 Control Register – 0xFC5.....	544
SPOT4 Control Register – 0xFC6.....	544
SPOT4 Control Register – 0xFC7.....	544
SPOT4 Control Register – 0xFC8.....	544
SPOT4 Control Register – 0xFC9.....	545
SPOT4 Control Register – 0xFCA.....	545
SPOT4 Control Register – 0xFCB.....	545
SPOT4 Control Register – 0xFCC.....	545
SPOT4 Control Register – 0xFCD	546
SPOT4 Control Register – 0xFCE.....	546
SPOT4 Control Register – 0XFCF	546
SPOT4 Control Register – 0xFD0	546
SPOT4 Control Register – 0xFD1	546
SPOT4 Control Register – 0xFD2	547
SPOT4 Control Register – 0xFD3	547
SPOT4 Control Register – 0xFD4	547
SPOT4 Control Register – 0xFD5	547
SPOT4 Control Register – 0xFD6	547
SPOT4 Control Register – 0xFD7	548
SPOT4 Control Register – 0xFD8	548
SPOT4 Control Register – 0xFD9	549
SPOT4 Control Register – 0xFDA	549
SPOT4 Control Register – 0xFDB	549
SPOT4 Control Register – 0xFDC	550
SPOT4 Control Register – 0xFDD	550
SPOT4 Control Register – 0xFDE	550
SPOT4 Control Register – 0XDF	550
SPOT4 Control Register – 0xFE0.....	551
SPOT4 Control Register – 0xFE1.....	551
SPOT4 Control Register – 0xFE2.....	552
SPOT4 OSD Font Size Register – 0xFE3	553
SPOT4 OSD Time and Date Horizontal Position Low Byte Register – 0xFE4.....	553
SPOT4 OSD Time and Date Horizontal Position High Byte Register – 0xFE5.....	553
SPOT4 OSD Time and Date Vertical Position Low Byte Register – 0xFE6.....	553
SPOT4 OSD Time and Date Vertical Position High Byte Register – 0xFE7.....	554
SPOT4 OSD Title Horizontal Position Low Byte Register – 0xFE8	554
SPOT4 OSD Title Horizontal Position High Byte Register – 0xFE9	554
SPOT4 OSD Title Vertical Position Low Byte Register – 0xFEA.....	554
SPOT4 OSD Title Horizontal Position High Byte Register – 0xFEB	554
SPOT4 OSD Font and Picture RAM Address Low Byte Register – 0xFEC	554

SPOT4 OSD Font and Picture RAM Address High Byte Register - 0xFED	554
SPOT4 OSD Font and Picture RAM Data Low Byte Register - 0xFEE	555
SPOT4 OSD Font and Picture RAM Data High Byte Register - 0xFEf	555
SPOT Channel0 position mapping Register - 0xFF0	555
SPOT Channel1 position mapping Register - 0xFF1	556
SPOT Channel2 position mapping Register - 0xFF2	556
SPOT Channel3 position mapping Register - 0xFF3	557
SPOT Channel4 position mapping Register - 0xFF4	558
SPOT Channel5 position mapping Register - 0xFF5	558
SPOT Channel6 position mapping Register - 0xFF6	559
SPOT Channel7 position mapping Register - 0xFF7	560
SPOT Channel8 position mapping Register - 0xFF8	560
SPOT Channel9 position mapping Register - 0xFF9	561
SPOT Channel10 position mapping Register - 0xFFA	562
SPOT Channel11 position mapping Register - 0xFFB	562
SPOT Channel12 position mapping Register - 0xFFC	563
SPOT Channel13 position mapping Register - 0xFFD	564
SPOT Channel14 position mapping Register - 0xFFE	564
SPOT Channel15 position mapping Register - 0xFFFF	565
Bitmap OSD for SPOT	566
Introduction	566
Features	566
Theory of Operation	566
Register Table	568
Registers Definition	571
Bitmap source vertical position Register 1 - 0x080	571
Bitmap source vertical position Register 2 - 0x081	571
Bitmap source horizontal position Register 1 - 0x082	571
Bitmap source horizontal position Register 2 - 0x083	571
Bitmap source vertical Size Register 1 - 0x088	571
Bitmap source vertical Size Register 2 - 0x089	571
Bitmap source horizontal Size Register - 0x08a	571
SPOT1 Bitmap Destination vertical position Register 1 - 0x084	571
SPOT1 Bitmap Destination vertical position Register 2 - 0x085	572
SPOT1 Bitmap Destination horizontal position Register 3 - 0x086	572
SPOT1 Bitmap Destination horizontal position Register 4 - 0x087	572
SPOT1 Bitmap Destination vertical Size Register 1 - 0x08b	572
SPOT1 Bitmap Destination vertical Size Register 2 - 0x08c	572
SPOT1 Bitmap Destination horizontal Size Register 1 - 0x08d	572
SPOT1 Bitmap Start Line Register 1 - 0x08e	572
SPOT1 Bitmap Start Line Register 2 - 0x08f	572
SPOT1 Bitmap Start Pixel Register 1 - 0x090	572
SPOT1 Bitmap Start Pixel Register 2 - 0x091	572
SPOT1 Bitmap Control Register 1 - 0x092	573
SPOT1 Bitmap Control Register 2 - 0x093	573
SPOT1 Bitmap Control Register 3 - 0x094	573
Bitmap DMA enable Control Register 3 - 0x095	573
SPOT1 Bitmap Control Register 3 - 0x096	574
SPOT1 Color look-up table1.Y - 0x097	574
SPOT1 Color look-up table1.Cb - 0x098	574
SPOT1 Color look-up table1.Cr - 0x099	574
SPOT1 Color look-up table2.Y - 0x09a	574
SPOT1 Color look-up table2.Cb - 0x09b	574
SPOT1 Color look-up table2.Cr - 0x09c	574
SPOT1 Color look-up table3.Y - 0x09d	574
SPOT1 Color look-up table3.Cb - 0x09e	574

SPOT1 Color look-up table3.Cr – 0x09f	574
SPOT2 Bitmap Destination vertical position Register 1 – 0x0a4	575
SPOT2 Bitmap Destination vertical position Register 2 – 0x0a5	575
SPOT2 Bitmap Destination horizontal position Register 1 – 0x0a6	575
SPOT2 Bitmap Destination horizontal position Register 2 – 0x0a7	575
SPOT2 Bitmap Destination vertical Size Register 1 – 0x0ab	575
SPOT2 Bitmap Destination vertical Size Register 2 – 0x0ac	575
SPOT2 Bitmap Destination horizontal Size Register – 0x0ad	575
SPOT2 Bitmap Start Line Register 1 – 0x0ae	575
SPOT2 Bitmap Start Line Register 2 – 0x0af	576
SPOT2 Bitmap Start Pixel Register 1 – 0x0b0	576
SPOT2 Bitmap Start Pixel Register 2 – 0x0b1	576
SPOT2 Bitmap Control Register 1 – 0x0b2	576
SPOT2 Bitmap Control Register 2 – 0x0b3	576
SPOT2 Bitmap Control Register 3 – 0x0b4	577
SPOT2 Bitmap Control Register 3 – 0x0b6	577
SPOT2 Color look-up table1.Y – 0x0b7	577
SPOT2 Color look-up table1.Cb – 0x0b8	577
SPOT2 Color look-up table1.Cr – 0x0b9	577
SPOT2 Color look-up table2.Y – 0x0ba	577
SPOT2 Color look-up table2.Cb – 0x0bb	577
SPOT2 Color look-up table2.Cr – 0x0bc	577
SPOT2 Color look-up table3.Y – 0x0bd	577
SPOT2 Color look-up table3.Cb – 0x0be	577
SPOT2 Color look-up table3.Cr – 0x0bf	578
SPOT3 Bitmap Destination vertical position Register 1 – 0x0c4	578
SPOT3 Bitmap Destination vertical position Register 2 – 0x0c5	578
SPOT3 Bitmap Destination horizontal position Register 1 – 0x0c6	578
SPOT3 Bitmap Destination horizontal position Register 2 – 0x0c7	578
SPOT3 Bitmap Destination vertical Size Register 1 – 0x0cb	578
SPOT3 Bitmap Destination vertical Size Register 2 – 0x0cc	578
SPOT3 Bitmap Destination horizontal Size Register – 0x0cd	578
SPOT3 Bitmap Start Line Register 1 – 0x0ce	578
SPOT3 Bitmap Start Line Register 2 – 0x0cf	579
SPOT3 Bitmap Start Pixel Register 1 – 0x0d0	579
SPOT3 Bitmap Start Pixel Register 2 – 0x0d1	579
SPOT3 Bitmap Control Register 1 – 0x0d2	579
SPOT3 Bitmap Control Register 2 – 0x0d3	579
SPOT3 Bitmap Control Register 3 – 0x0d4	580
SPOT3 Bitmap Control Register 3 – 0x0d6	580
SPOT3 Color look-up table1.Y – 0x0d7	580
SPOT3 Color look-up table1.Cb – 0x0d8	580
SPOT3 Color look-up table1.Cr – 0x0d9	580
SPOT3 Color look-up table2.Y – 0x0da	580
SPOT3 Color look-up table2.Cb – 0x0db	580
SPOT3 Color look-up table2.Cr – 0x0dc	580
SPOT3 Color look-up table3.Y – 0x0dd	580
SPOT3 Color look-up table3.Cb – 0x0de	580
SPOT3 Color look-up table3.Cr – 0x0df	581
SPOT4 Bitmap Destination vertical position Register 1 – 0x0e4	581
SPOT4 Bitmap Destination vertical position Register 2 – 0x0e5	581
SPOT4 Bitmap Destination horizontal position Register 3 – 0x0e6	581
SPOT4 Bitmap Destination horizontal position Register 4 – 0x0e7	581
SPOT4 Bitmap Destination vertical Size Register 1 – 0x0eb	581
SPOT4 Bitmap Destination vertical Size Register 2 – 0x0ec	581
SPOT4 Bitmap Destination horizontal Size Register – 0x0ed	581
SPOT4 Bitmap Start Line Register 1 – 0x0ee	581

SPOT4 Bitmap Start Line Register 2 – 0x0ef.....	582
SPOT4 Bitmap Start Pixel Register 1 – 0x0f0.....	582
SPOT4 Bitmap Start Pixel Register 2 – 0x0f1.....	582
SPOT4 Bitmap Control Register 1 – 0x0f2.....	582
SPOT4 Bitmap Control Register 2 – 0x0f3.....	582
SPOT4 Bitmap Control Register 3 – 0x0f4.....	583
SPOT4 Bitmap Control Register 3 – 0x0f6.....	583
SPOT4 Color look-up table1.Y – 0x0f7.....	583
SPOT4 Color look-up table1.Cb – 0x0f8.....	583
SPOT4 Color look-up table1.Cr – 0x0f9.....	583
SPOT4 Color look-up table2.Y – 0x0fa.....	583
SPOT4 Color look-up table2.Cb – 0x0fb.....	583
SPOT4 Color look-up table2.Cr – 0x0fc.....	583
SPOT4 Color look-up table3.Y – 0x0fd.....	583
SPOT4 Color look-up table3.Cb – 0x0fe.....	583
SPOT4 Color look-up table3.Cr – 0x0ff.....	584
Bitmap Write Data – 0x23e.....	584
PB Input Clock Delay Register – 0x23f.....	584
Bitmap Display Pitch Register 1 – 0x25d.....	584
Bitmap Initial Address Register 1 – 0x265.....	584
Bitmap Initial Address Register 2 – 0x266.....	584
Bitmap Initial Address Register 3 – 0x267.....	584
Bitmap Wait Enable Register 1 – 0x249.....	584
Bitmap Wait Enable Register 2 – 0x24a.....	585
OSG Bitmap Total Size Register 1 – 0x24b.....	585
OSG Bitmap Total Size Register 2 – 0x24c.....	585
OSG Bitmap Total Size Register 3 – 0x24d.....	585
OSG Bitmap Total Size Register 4 – 0x24e.....	585
OSG Bitmap Control Register – 0x24f.....	585
Host Interface.....	586
Introduction.....	586
Pin Assignments for Serial and Parallel Interface.....	586
Serial Interface.....	587
Parallel Interface.....	588
Single Transfer.....	588
Burst Transfer.....	590
External Host Interface Connection.....	591
External Host to Display Memory access Interface.....	591
DMA Interface.....	591
Interrupt Interface.....	592
Register Table.....	594
Registers Description.....	595
No video IRQ Enable Register 1 – 0xCB0.....	595
No video IRQ Enable Register 2 – 0xCB1.....	595
Motion Detection IRQ Enable Register 1 – 0xCB2.....	595
Motion Detection IRQ Enable Register 2 – 0xCB3.....	595
Blind Detection IRQ Enable Register 1 – 0xCB4.....	595
Blind Detection IRQ Enable Register 2 – 0xCB5.....	595
Night Detection IRQ Enable Register 1 – 0xCB6.....	596
Night Detection IRQ Enable Register 2 – 0xCB7.....	596
No video IRQ Status Register 1 – 0xCB8.....	596
No video IRQ Status Register 2 – 0xCB9.....	596
Motion Detection IRQ Status Register 1 – 0xCBA.....	596
Motion Detection IRQ Status Register 2 – 0xCBB.....	596
Blind Detection IRQ Status Register 1 – 0CBC.....	597
Blind Detection IRQ Status Register 2 – 0CBD.....	597

Night Detection IRQ Status Register 1 – 0xCB	597
Night Detection IRQ Status Register 2 – 0xCB	597
IRQ Main Control Register –Offset 0xCC0	597
IRQ Spacing Register – 0xCC1	597
IRQ Report Counter Register 1 – 0xCC2	598
IRQ Report Counter Register 2 – 0xCC3	598
IRQ Report Counter Register 3 – 0xCC4	598
AUX. IRQ Status Register –Offset 0xCC6	598
MPOUT Selection Register –Offset 0xCC7	599
Display DRAM Address Register 0 – 0x000	599
Display DRAM Address Register 1– 0x001	599
Display DRAM Address Register 2– 0x002	599
Display DRAM access Control Register –Offset 0x003	600
Display DRAM Data Port Register– 0x004	600
Clock Synthesizer and Pin MUX	601
Introduction	601
Clock Synthesizer Circuit	601
Output Clock Summary	601
Initial Conditions and Changing PLL values	602
RESET Logic	602
Playback Pin Mux	602
Power On Sequence	603
Live Video Pin Mux	603
Port 80 Display	604
HDMI Transmitter Signal Adjustment	604
Register Table	606
Registers Description	608
Audio Control Register –Offset 0x200	608
Misc. Control Register –Offset 0x201	608
MPLL M Duty Cycle Control Register (MPLLMR) –Offset 0x202	608
MPLL N Multiplier Factor Register (MPLLNR) –Offset 0x203	608
VPLL M Duty Cycle Control Register (VPLLMR) –Offset 0x204	609
VPLL N Multiplier Factor Register (VPLLNR) –Offset 0x205	609
SPLL M Duty Cycle Control Register (SPLLMR) –Offset 0x206	609
SPLL N Multiplier Factor Register (SPLLNR) –Offset 0x207	609
MCLK PLL Divider Control Register 1 –Offset 0x208 (Upper Byte at 0x220)	609
VCLK PLL Divider Control Register 1 –Offset 0x209 (Upper byte at x221 .. x223)	610
IN Rate Select Register –Offset 0x20A	610
Digital Block Reset Control Register 1 –Offset 0x20B	610
Digital Block Reset Control Register 2 –Offset 0x20C	611
Digital Block Reset Control Register 3 –Offset 0x20D	611
Digital Block Reset Control Register 4 –Offset 0x20E	612
Digital Block Reset Control Register 5 –Offset 0x20F	612
LCD Display Pitch Register – Offset 0x210	613
Display DRAM Controller Configuration Register – 0x211	613
Recording DRAM Controller Configuration Register – 0x212	613
Port 80 Control Register – 0x213	614
Port 80 Content Register 1 – 0x214	614
Port 80 Content Register 2 – 0x215	614
SPLL Phase Control Register I –Offset 0x216	615
PLL Soft Reset Control Register –Offset 0x217	615
REC output Clock phase Control Register 1 –Offset 0x218	615
REC output Clock phase Control Register 2 –Offset 0x219	616
TV decoder output Clock select Register –Offset 0x21A	616
HDMI physical interface Control Register –Offset 0x21B	617
Live input clock phase select Register –Offset 0x21C	617

DRAM Space access select Register —Offset 0x21D.....	618
Network port data source select Register —Offset 0x21E	618
SCLK Phase Control Register 2 —Offset 0x21F	619
MCLK Phase Control Register 2 —Offset 0x220	619
VCLK PLL Divider Control Register 2 —Offset 0x221	620
VCLK PLL Divider Control Register 3 —Offset 0x222	620
VCLK PLL Divider Control Register 4 —Offset 0x223	621
LP_CON1 x Control Register —Offset 0x224	621
LP_CON2 x Control Register —Offset 0x225	622
LP_CON3 x Control Register —Offset 0x226	623
LP_CON4 x Control Register —Offset 0x227	623
Audio Control 1 Register - 0x228.....	624
Audio Control 2 Register - 0x229.....	624
Recording Pin Port Data Select Register — 0x22A.....	625
CPU Fast Access Control Register — 0x22C.....	625
CPU Freeze Display Pitch Register — 0x22D	626
SCLK Phase Control Register 3 —Offset 0x22E	626
DRAM Address Mapping Register — 0x26D	626
Chip ID Register — 0x270.....	626
Display DRAM Priority Arbitration Register 1 — 0x280	627
Display DRAM Priority Arbitration Register 2 — 0x281	627
Display DRAM Priority Arbitration Register 3 — 0x282	627
Record DRAM Priority Arbitration Register 1 — 0x284.....	627
Record DRAM Priority Arbitration Register 2 — 0x285.....	628
Record DRAM Priority Arbitration Register 3 — 0x286.....	628
I²C MASTER CONTROL	629
Introduction	629
Features	629
Operation	629
Register Table.....	631
Registers	631
I ² C Bus Frequency Control Register (Lower) —Offset 0x770.....	631
I ² C Bus Frequency Control Register (Upper) —Offset 0x771.....	631
I ² C Command / Data Register —Offset 0x772.....	631
I ² C Data Read Register —Offset 0x773.....	631
I ² C Command Register —Offset 0x774	631
I ² C Command Status Register —Offset 0x775.....	632
Revision History.....	633

Display Format

The TW2880 supports many VESA standard display formats, as listed below. The following is a summary. Please remember that these are only a small fraction of the supported VESA modes. Refresh frequency is flexible and is adjustable based on the dot video clock, horizontal total and vertical total.

STANDARD	ACTIVE PIXEL	TOTAL PIXEL	F _v (HZ)	F _H (kHz)	CLOCK (MHz)
XGA	1024x768	1312x797	50	42.50	51.75
XGA	1024x768	1344x806	70	56.47	75.00
XGA	1024x768	1344x806	75	60.02	78.75
SXGA	1280x1024	1696x1054	50	38.12	89.38
SXGA	1280x1024	1712x1080	60.020	49.31	108.10
WXGA(II)	1440x900	1600x950	59.90	55.47	100.00
WSXGA+	1680x1050	1840x1080	59.98	64.67	122.00
HD1080	1920x1080	2200x1125	59.98	67.37	148.50

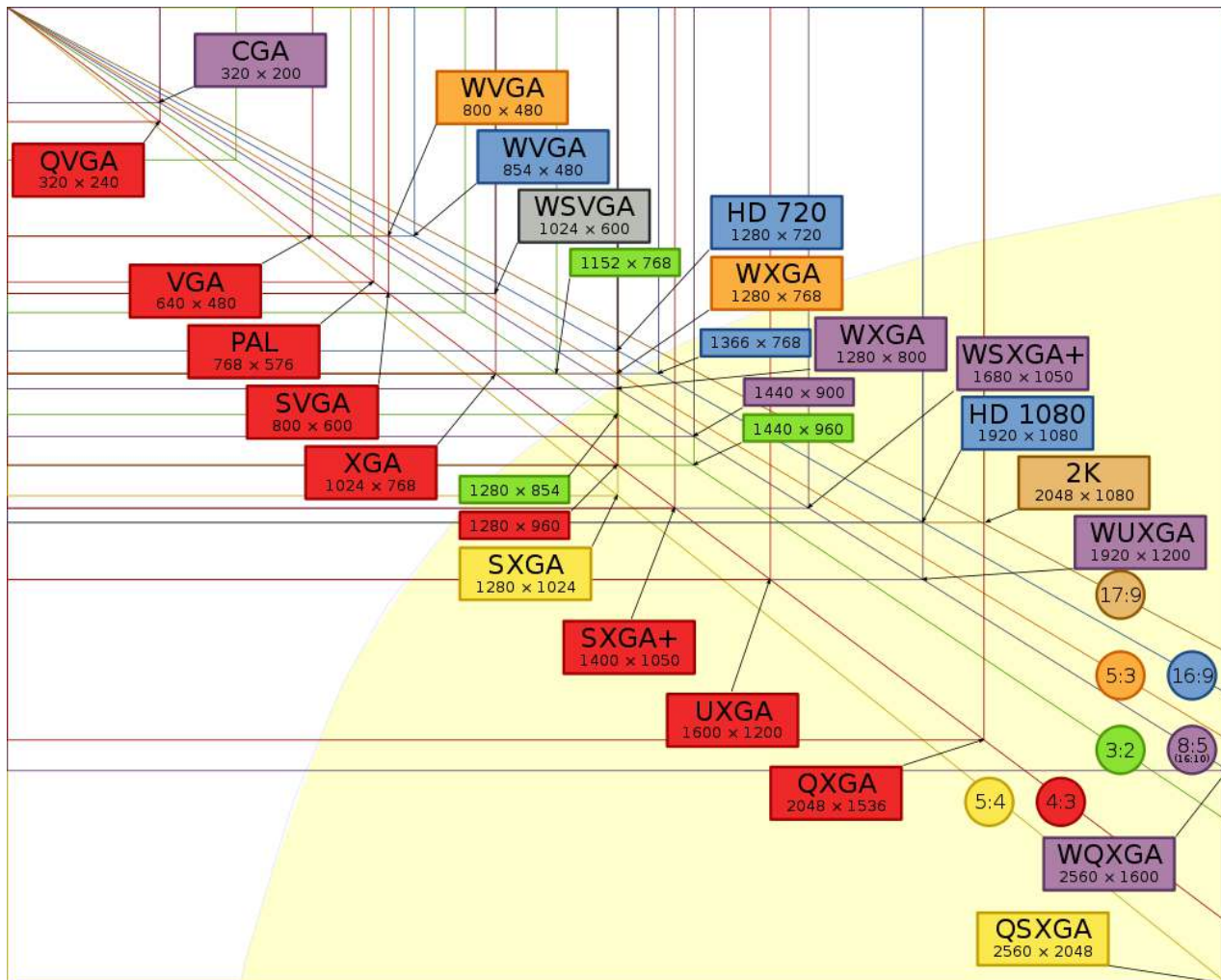

System Diagram

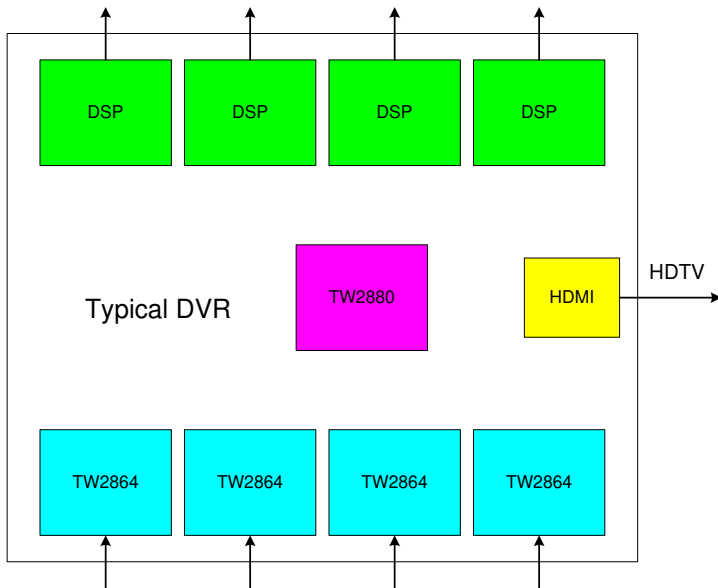
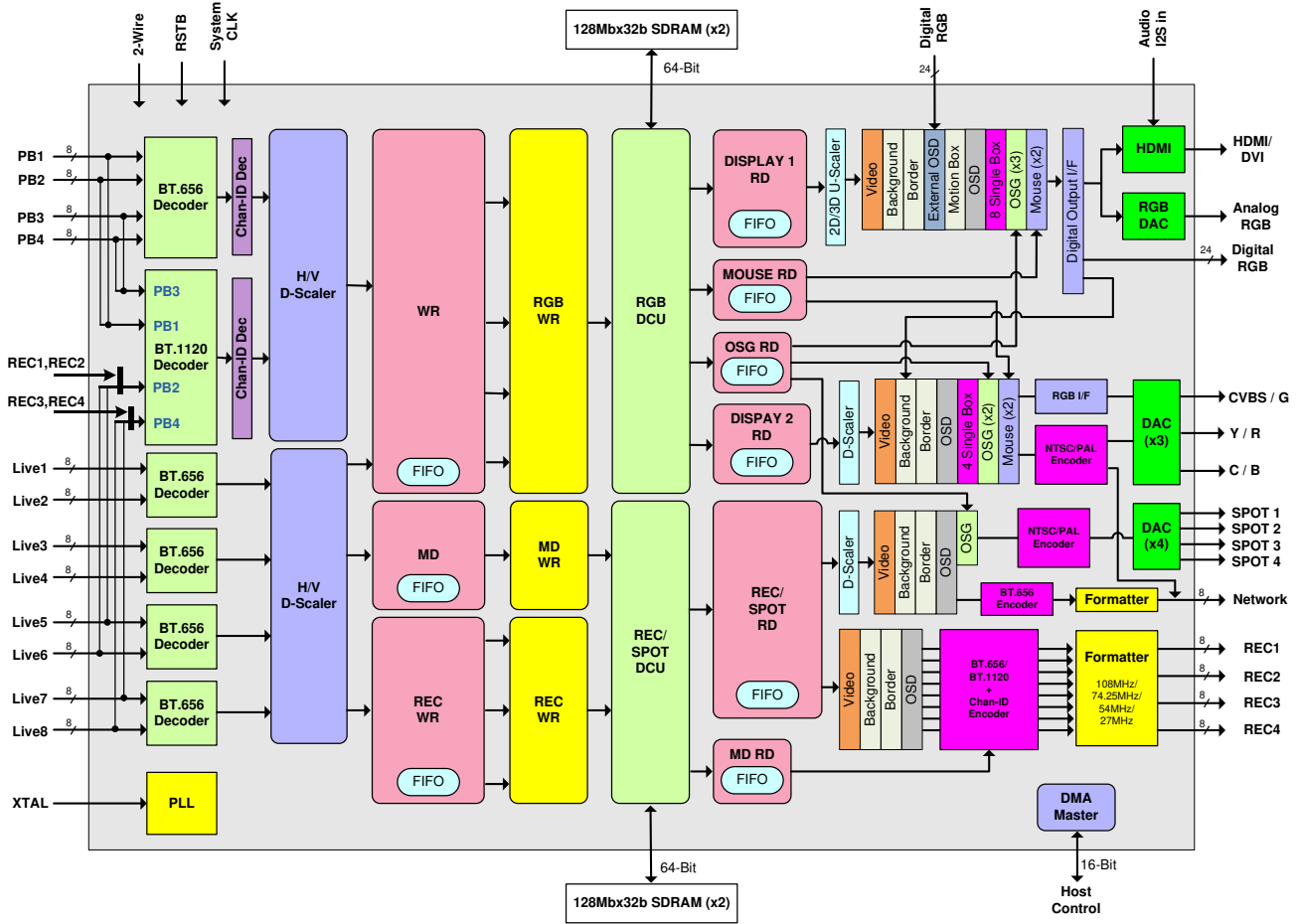

Ball Description

(436 signal pins + 40 Analog VCC/GND + 200 VCC/GND)

TABLE 1. BALL DESCRIPTION OF VIDEO INPUT INTERFACE

Ball(s) No.	Symbol	Attribute	Description
A2	P_ckvin15	I	<i>Clock Input for multiplexed Video1 and Video5</i>
H6	P_ckvin26	I	<i>Clock Input for multiplexed Video2 and Video6</i>
J3	P_ckvin37	I	<i>Clock Input for multiplexed Video3 and Video7</i>
M4	P_ckvin48	I	<i>Clock Input for multiplexed Video4 and Video8</i>
C3	P_din1[0]	I	<i>Port1 Video Input bit 0</i>
D4	P_din1[1]	I	<i>Port1 Video Input bit 1</i>
E5	P_din1[2]	I	<i>Port1 Video Input bit 2</i>
G7	P_din1[3]	I	<i>Port1 Video Input bit 3</i>
B1	P_din1[4]	I	<i>Port1 Video Input bit 4</i>
C2	P_din1[5]	I	<i>Port1 Video Input bit 5</i>
D3	P_din1[6]	I	<i>Port1 Video Input bit 6</i>
E4	P_din1[7]	I	<i>Port1 Video Input bit 7</i>
F5	P_din2[0]	I	<i>Port2 Video Input bit 0</i>
G6	P_din2[1]	I	<i>Port2 Video Input bit 1</i>
C1	P_din2[2]	I	<i>Port2 Video Input bit 2</i>
D2	P_din2[3]	I	<i>Port2 Video Input bit 3</i>
H7	P_din2[4]	I	<i>Port2 Video Input bit 4</i>
E3	P_din2[5]	I	<i>Port2 Video Input bit 5</i>
F4	P_din2[6]	I	<i>Port2 Video Input bit 6</i>
G5	P_din2[7]	I	<i>Port2 Video Input bit 7</i>
D1	P_din3[0]	I	<i>Port3 Video Input bit 0</i>
E2	P_din3[1]	I	<i>Port3 Video Input bit 1</i>
F3	P_din3[2]	I	<i>Port3 Video Input bit 2</i>
G4	P_din3[3]	I	<i>Port3 Video Input bit 3</i>
H5	P_din3[4]	I	<i>Port3 Video Input bit 4</i>
E1	P_din3[5]	I	<i>Port3 Video Input bit 5</i>
G3	P_din3[6]	I	<i>Port3 Video Input bit 6</i>
H4	P_din3[7]	I	<i>Port3 Video Input bit 7</i>
J5	P_din4[0]	I	<i>Port4 Video Input bit 0</i>
G2	P_din4[1]	I	<i>Port4 Video Input bit 1</i>
H3	P_din4[2]	I	<i>Port4 Video Input bit 2</i>
G1	P_din4[3]	I	<i>Port4 Video Input bit 3</i>
H2	P_din4[4]	I	<i>Port4 Video Input bit 4</i>
J4	P_din4[5]	I	<i>Port4 Video Input bit 5</i>
H1	P_din4[6]	I	<i>Port4 Video Input bit 6</i>
J7	P_din4[7]	I	<i>Port4 Video Input bit 7</i>
K7	P_din5[0]	B	<i>Port5 Video Input bit 0 / Multi-purpose pin / R0</i>
K6	P_din5[1]	B	<i>Port5 Video Input bit 1 / Multi-purpose pin / R1</i>
L7	P_din5[2]	B	<i>Port5 Video Input bit 2 / Multi-purpose pin / R2</i>
L6	P_din5[3]	B	<i>Port5 Video Input bit 3 / Multi-purpose pin / R3</i>
J2	P_din5[4]	B	<i>Port5 Video Input bit 4 / Multi-purpose pin / R4</i>
J1	P_din5[5]	B	<i>Port5 Video Input bit 5 / Multi-purpose pin / R5</i>
K5	P_din5[6]	B	<i>Port5 Video Input bit 6 / Multi-purpose pin / R6</i>
K4	P_din5[7]	B	<i>Port5 Video Input bit 7 / Multi-purpose pin / R7</i>
K3	P_din6[0]	B	<i>Port6 Video Input bit 0 / Multi-purpose pin / G0</i>
K2	P_din6[1]	B	<i>Port6 Video Input bit 1 / Multi-purpose pin / G1</i>
K1	P_din6[2]	B	<i>Port6 Video Input bit 2 / Multi-purpose pin / G2</i>
L5	P_din6[3]	B	<i>Port6 Video Input bit 3 / Multi-purpose pin / G3</i>
L4	P_din6[4]	B	<i>Port6 Video Input bit 4 / Multi-purpose pin / G4</i>
L3	P_din6[5]	B	<i>Port6 Video Input bit 5 / Multi-purpose pin / G5</i>

Ball(s) No.	Symbol	Attribute	Description
M5	P_din6[6]	B	Port6 Video Input bit 6 / Multi-purpose pin / G6
M7	P_din6[7]	B	Port6 Video Input bit 7 / Multi-purpose pin / G7
M3	P_din7[0]	B	Port7 Video Input bit 0 / Multi-purpose pin / B0
M2	P_din7[1]	B	Port7 Video Input bit 1 / Multi-purpose pin / B1
M1	P_din7[2]	B	Port7 Video Input bit 2 / Multi-purpose pin / B2
N6	P_din7[3]	B	Port7 Video Input bit 3 / Multi-purpose pin / B3
N7	P_din7[4]	B	Port7 Video Input bit 4 / Multi-purpose pin / B4
N5	P_din7[5]	B	Port7 Video Input bit 5 / Multi-purpose pin / B5
N4	P_din7[6]	B	Port7 Video Input bit 6 / Multi-purpose pin / B6
N3	P_din7[7]	B	Port7 Video Input bit 7 / Multi-purpose pin / B7
N2	P_din8[0]	B	Port8 Video Input bit 0 / external OSD enable / LCD_DE (output)
N1	P_din8[1]	B	Port8 Video Input bit 1 / VCLK output
P1	P_din8[2]	I	Port8 Video Input bit 2
P2	P_din8[3]	I	Port8 Video Input bit 3
P3	P_din8[4]	I	Port8 Video Input bit 4
P6	P_din8[5]	I	Port8 Video Input bit 5
P4	P_din8[6]	I	Port8 Video Input bit 6
P5	P_din8[7]	I	Port8 Video Input bit 7

TABLE 2. BALL DESCRIPTION OF PLAYBACK INPUT INTERFACE

Ball(s) No.	Symbol	Attribute	Description
P7	P_ck27pb1	I	Clock Input for playback port1
R1	P_din_pb1[0]	I	Playback Port1 Input bit 0
R2	P_din_pb1[1]	I	Playback Port1 Input bit 1
R3	P_din_pb1[2]	I	Playback Port1 Input bit 2
R4	P_din_pb1[3]	I	Playback Port1 Input bit 3
R7	P_din_pb1[4]	I	Playback Port1 Input bit 4
R5	P_din_pb1[5]	I	Playback Port1 Input bit 5
T7	P_din_pb1[6]	I	Playback Port1 Input bit 6
T6	P_din_pb1[7]	I	Playback Port1 Input bit 7
U6	P_ck27pb2	I	Clock Input for playback port2
V1	P_din_pb2[0]	I	Playback Port2 Input bit 0
V2	P_din_pb2[1]	I	Playback Port2 Input bit 1
V3	P_din_pb2[2]	I	Playback Port2 Input bit 2
V4	P_din_pb2[3]	I	Playback Port2 Input bit 3
W1	P_din_pb2[4]	I	Playback Port2 Input bit 4
V5	P_din_pb2[5]	I	Playback Port2 Input bit 5
U7	P_din_pb2[6]	I	Playback Port2 Input bit 6
W2	P_din_pb2[7]	I	Playback Port2 Input bit 7
V7	P_bt601_H1	O	DACK signal In DMA mode
Y1	P_bt601_V1	I	HDONE signal In DMA mode, tie to ground if not used
W3	P_ck27pb3	I	Clock Input for playback port3
Y2	P_din_pb3[0]	I	Playback Port3 Input bit 0
Y3	P_din_pb3[1]	I	Playback Port3 Input bit 1
W4	P_din_pb3[2]	I	Playback Port3 Input bit 2
AB1	P_din_pb3[3]	I	Playback Port3 Input bit 3
AC1	P_din_pb3[4]	I	Playback Port3 Input bit 4
AB2	P_din_pb3[5]	I	Playback Port3 Input bit 5
AA3	P_din_pb3[6]	I	Playback Port3 Input bit 6
Y4	P_din_pb3[7]	I	Playback Port3 Input bit 7
W5	P_ck27pb4	I	Clock Input for playback port4
AD1	P_din_pb4[0]	I	Playback Port4 Input bit 0
AC2	P_din_pb4[1]	I	Playback Port4 Input bit 1

Ball(s) No.	Symbol	Attribute	Description
AB3	P_din_pb4[2]	I	Playback Port4 Input bit 2
AA4	P_din_pb4[3]	I	Playback Port4 Input bit 3
Y5	P_din_pb4[4]	I	Playback Port4 Input bit 4
AE1	P_din_pb4[5]	I	Playback Port4 Input bit 5
AD2	P_din_pb4[6]	I	Playback Port4 Input bit 6
AC3	P_din_pb4[7]	I	Playback Port4 Input bit 7
AD3	P_bt601_H2	I	Reserved
W6	P_bt601_V2	I	Reserved

TABLE 3. BALL DESCRIPTION OF PLL INPUT INTERFACE

Ball(s) No.	Symbol	Attribute	Description
T1	P_xtal_in1	I	Crystal Input
T2	P_xtal_in2	O	Crystal Output

TABLE 4. BALL DESCRIPTION OF RRCORD PORT INTERFACE

Ball(s) No.	Symbol	Attribute	Description
AB4	P_rec1_clkn	O	Negative Clock output for record port1
Y6	P_rec1_clkp	O	Positive Clock output for record port1
AC4	P_rec1_enc_data[0]	B	Record Port1 output bit 0
W7	P_rec1_enc_data[1]	B	Record Port1 output bit 1
AA5	P_rec1_enc_data[2]	B	Record Port1 output bit 2
AB5	P_rec1_enc_data[3]	B	Record Port1 output bit 3
AD4	P_rec1_enc_data[4]	B	Record Port1 output bit 4
AE3	P_rec1_enc_data[5]	B	Record Port1 output bit 5
AF2	P_rec1_enc_data[6]	B	Record Port1 output bit 6
Y7	P_rec1_enc_data[7]	B	Record Port1 output bit 7
AA7	P_rec1_bt601_H1	B	Record Port1 Horizontal sync
AB6	P_rec1_bt601_V1	B	Record Port1 Vertical sync
AC5	P_rec1_bt601_F1	B	Record Port1 Field / ext clock input
AB7	P_rec2_clkn	O	Negative Clock output for record port2
AC6	P_rec2_clkp	O	Positive Clock output for record port2
AD5	P_rec2_enc_data[0]	B	Record Port2 output bit 0
AE4	P_rec2_enc_data[1]	B	Record Port2 output bit 1
AF3	P_rec2_enc_data[2]	B	Record Port2 output bit 2
Y8	P_rec2_enc_data[3]	B	Record Port2 output bit 3
AC7	P_rec2_enc_data[4]	B	Record Port2 output bit 4
AA8	P_rec2_enc_data[5]	B	Record Port2 output bit 5
AD6	P_rec2_enc_data[6]	B	Record Port2 output bit 6
AE5	P_rec2_enc_data[7]	B	Record Port2 output bit 7
AF4	P_rec2_bt601_H2	O	Record Port2 Horizontal sync
AF5	P_rec2_bt601_V2	O	Record Port2 Vertical sync
AB8	P_rec2_bt601_F2	O	Record Port2 Field
AC8	P_rec3_clkn	O	Negative Clock output for record port3
AD7	P_rec3_clkp	O	Positive Clock output for record port3
Y9	P_rec3_enc_data[0]	O	Record Port3 output bit 0
AB9	P_rec3_enc_data[1]	O	Record Port3 output bit 1
AC9	P_rec3_enc_data[2]	O	Record Port3 output bit 2
AD8	P_rec3_enc_data[3]	O	Record Port3 output bit 3
AA9	P_rec3_enc_data[4]	O	Record Port3 output bit 4

Ball(s) No.	Symbol	Attribute	Description
AE7	P_rec3_enc_data[5]	0	Record Port3 output bit 5
AD9	P_rec3_enc_data[6]	0	Record Port3 output bit 6
AE8	P_rec3_enc_data[7]	0	Record Port3 output bit 7
Y10	P_rec3_bt601_H3	0	Record Port3 Horizontal sync
AF7	P_rec3_bt601_V3	0	Record Port3 Vertical sync
AB10	P_rec3_bt601_F3	0	Record Port3 Field
AC10	P_rec4_clkn	0	Negative Clock output for record port4
AD10	P_rec4_clkp	0	Positive Clock output for record port4
AA10	P_rec4_enc_data[0]	0	Record Port4 output bit 0
AE9	P_rec4_enc_data[1]	0	Record Port4 output bit 1
AF8	P_rec4_enc_data[2]	0	Record Port4 output bit 2
AB11	P_rec4_enc_data[3]	0	Record Port4 output bit 3
AC11	P_rec4_enc_data[4]	0	Record Port4 output bit 4
AD11	P_rec4_enc_data[5]	0	Record Port4 output bit 5
Y11	P_rec4_enc_data[6]	0	Record Port4 output bit 6
AE10	P_rec4_enc_data[7]	0	Record Port4 output bit 7
AA11	P_rec4_bt601_H4	0	Record Port4 Horizontal sync
AF9	P_rec4_bt601_V4	0	Record Port4 Vertical sync
AF10	P_rec4_bt601_F4	0	Record Port4 Field

TABLE 5. BALL DESCRIPTION OF RECORD PORT DRAM INTERFACE

Ball(s) No.	Symbol	Attribute	Description
AA13	P_rec_ma[0]	0	Record port memory address 0
AC13	P_rec_ma[1]	0	Record port memory address 1
AD13	P_rec_ma[2]	0	Record port memory address 2
AE13	P_rec_ma[3]	0	Record port memory address 3
AF13	P_rec_ma[4]	0	Record port memory address 4
AF14	P_rec_ma[5]	0	Record port memory address 5
AE14	P_rec_ma[6]	0	Record port memory address 6
AA14	P_rec_ma[7]	0	Record port memory address 7
AD14	P_rec_ma[8]	0	Record port memory address 8
Y14	P_rec_ma[9]	0	Record port memory address 9
AC14	P_rec_ma[10]	0	Record port memory address 10
AB14	P_rec_ma[11]	0	Record port memory address 11
AF15	P_rec_dq[0]	B	Record port memory data 0
AE15	P_rec_dq[1]	B	Record port memory data 1
AD15	P_rec_dq[2]	B	Record port memory data 2
Y15	P_rec_dq[3]	B	Record port memory data 3
AC15	P_rec_dq[4]	B	Record port memory data 4
AB15	P_rec_dq[5]	B	Record port memory data 5
AF17	P_rec_dq[6]	B	Record port memory data 6
AD16	P_rec_dq[7]	B	Record port memory data 7
AE17	P_rec_dq[8]	B	Record port memory data 8

Ball(s) No.	Symbol	Attribute	Description
AF18	P_rec_dq[9]	B	<i>Record port memory data 9</i>
AC16	P_rec_dq[10]	B	<i>Record port memory data 10</i>
AA16	P_rec_dq[11]	B	<i>Record port memory data 11</i>
AD17	P_rec_dq[12]	B	<i>Record port memory data 12</i>
AE18	P_rec_dq[13]	B	<i>Record port memory data 13</i>
AF19	P_rec_dq[14]	B	<i>Record port memory data 14</i>
AB16	P_rec_dq[15]	B	<i>Record port memory data 15</i>
Y16	P_rec_dq[16]	B	<i>Record port memory data 16</i>
AC17	P_rec_dq[17]	B	<i>Record port memory data 17</i>
W16	P_rec_dq[18]	B	<i>Record port memory data 18</i>
AD18	P_rec_dq[19]	B	<i>Record port memory data 19</i>
AE19	P_rec_dq[20]	B	<i>Record port memory data 20</i>
AF20	P_rec_dq[21]	B	<i>Record port memory data 21</i>
AA17	P_rec_dq[22]	B	<i>Record port memory data 22</i>
AB17	P_rec_dq[23]	B	<i>Record port memory data 23</i>
Y17	P_rec_dq[24]	B	<i>Record port memory data 24</i>
AC18	P_rec_dq[25]	B	<i>Record port memory data 25</i>
AD19	P_rec_dq[26]	B	<i>Record port memory data 26</i>
AE20	P_rec_dq[27]	B	<i>Record port memory data 27</i>
AA18	P_rec_dq[28]	B	<i>Record port memory data 28</i>
AB18	P_rec_dq[29]	B	<i>Record port memory data 29</i>
Y18	P_rec_dq[30]	B	<i>Record port memory data 30</i>
AC19	P_rec_dq[31]	B	<i>Record port memory data 31</i>
AF23	P_rec_dq[32]	B	<i>Record port memory data 32</i>
AB20	P_rec_dq[33]	B	<i>Record port memory data 33</i>
AC21	P_rec_dq[34]	B	<i>Record port memory data 34</i>
AD22	P_rec_dq[35]	B	<i>Record port memory data 35</i>
AE23	P_rec_dq[36]	B	<i>Record port memory data 36</i>
AF24	P_rec_dq[37]	B	<i>Record port memory data 37</i>
AB21	P_rec_dq[38]	B	<i>Record port memory data 38</i>
AA19	P_rec_dq[39]	B	<i>Record port memory data 39</i>
AC22	P_rec_dq[40]	B	<i>Record port memory data 40</i>
AD23	P_rec_dq[41]	B	<i>Record port memory data 41</i>
AE24	P_rec_dq[42]	B	<i>Record port memory data 42</i>
AA20	P_rec_dq[43]	B	<i>Record port memory data 43</i>
AF25	P_rec_dq[44]	B	<i>Record port memory data 44</i>
Y19	P_rec_dq[45]	B	<i>Record port memory data 45</i>

Ball(s) No.	Symbol	Attribute	Description
AD24	P_rec_dq[46]	B	Record port memory data 46
Y20	P_rec_dq[47]	B	Record port memory data 47
AC23	P_rec_dq[48]	B	Record port memory data 48
AB22	P_rec_dq[49]	B	Record port memory data 49
AA22	P_rec_dq[50]	B	Record port memory data 50
AB23	P_rec_dq[51]	B	Record port memory data 51
W20	P_rec_dq[52]	B	Record port memory data 52
AC24	P_rec_dq[53]	B	Record port memory data 53
Y21	P_rec_dq[54]	B	Record port memory data 54
AD25	P_rec_dq[55]	B	Record port memory data 55
AE26	P_rec_dq[56]	B	Record port memory data 56
Y22	P_rec_dq[57]	B	Record port memory data 57
W21	P_rec_dq[58]	B	Record port memory data 58
AA23	P_rec_dq[59]	B	Record port memory data 59
AB24	P_rec_dq[60]	B	Record port memory data 60
AC25	P_rec_dq[61]	B	Record port memory data 61
AD26	P_rec_dq[62]	B	Record port memory data 62
W22	P_rec_dq[63]	B	Record port memory data 63
AD20	P_rec_rasb	O	Record port DRAM control RASB
AF22	P_rec_casb	O	Record port DRAM control CASB
AB19	P_rec_web	O	Record port DRAM control WEB
AC20	P_rec_dram_clk	O	Record port DRAM control CLK
AD21	P_rec_ba[0]	O	Record port DRAM control BANK0
AE22	P_rec_ba[1]	O	Record port DRAM control BANK1

TABLE 6. BALL DESCRIPTION OF SPOT PORT INTERFACE

Ball(s) No.	Symbol	Attribute	Description
P26	P_ana_spot1_VREF	I	SPOT1 DAC voltage reference (connect to 1.1 VDC)
N23	P_ana_spot1_VRO	O	SPOT1 DAC Full-scale Current Adjust Connect 2.7 K Ω (typ) between this pin and Analog GND
N24	P_ana_spot1_CVBS	O	SPOT1, Analog composite TV signal
N25	P_ana_spot2_VREF	I	SPOT2 DAC voltage reference (connect to 1.1 VDC)
N26	P_ana_spot2_VRO	O	SPOT2 DAC Full-scale Current Adjust Connect 2.7 K Ω (typ) between this pin and Analog GND
N22	P_ana_spot2_CVBS	O	SPOT2, Analog composite TV signal
AB12	P_ana_spot3_VREF	I	SPOT3 DAC voltage reference (connect to 1.1 VDC)
AC12	P_ana_spot3_VRO	O	SPOT3 DAC Full-scale Current Adjust Connect 2.7 K Ω (typ) between this pin and Analog GND
AD12	P_ana_spot3_CVBS	O	SPOT3, Analog composite TV signal
AE12	P_ana_spot4_VREF	I	SPOT4 DAC voltage reference (connect to 1.1 VDC)
AF12	P_ana_spot4_VRO	O	SPOT4 DAC Full-scale Current Adjust Connect 2.7 K Ω (typ) between this pin and Analog GND
AB13	P_ana_spot4_CVBS	O	SPOT4, Analog composite TV signal

TABLE 7. BALL DESCRIPTION OF HOST PORT INTERFACE

Ball(s) No.	Symbol	Attribute	Description
Y23	P_rstb	I	Chip Reset when it is LOW
AC26	P_hspb	I	I ² C Interface when this bit is 1. Parallel Interface If HSBP is 0
V20	P_hcsb	I	In I ² C mode, this bit is SCK, In Parallel Mode, It is Chip Select
V22	P_hwrb	I	N/A In I ² C mode. In Parallel Mode, It is WRITE enable when 0
W23	P_hrdb	I	N/A In I ² C mode. In Parallel Mode, It is READ enable when 0
AA24	P_wait_st	O	Host waiting indication from OSG
AB25	P_h16b_en	I	8 / 16 bit mode select, high = Enable 16 bit host mode
Y24	P_haddr[0]	I	Host address bit 0
AB26	P_haddr[1]	I	Host address bit 1
U20	P_haddr[2]	I	Host address bit 2
U22	P_haddr[3]	I	Host address bit 3
U21	P_haddr[4]	I	Host address bit 4
V23	P_haddr[5]	I	Host address bit 5
W24	P_haddr[6]	I	Host address bit 6
Y25	P_haddr[7]	I	Host address bit 7
T20	P_haddr[8]	I	Host address bit 8
T22	P_haddr[9]	I	Host address bit 9
T21	P_haddr[10]	I	Host address bit 10
U23	P_haddr[11]	I	Host address bit 11
V24	P_hdat[0]	B	Host data bit 0
W25	P_hdat[1]	B	Host data bit 1
Y26	P_hdat[2]	B	Host data bit 2
T23	P_hdat[3]	B	Host data bit 3
U24	P_hdat[4]	B	Host data bit 4
V25	P_hdat[5]	B	Host data bit 5
W26	P_hdat[6]	B	Host data bit 6
T24	P_hdat[7]	B	Host data bit 7 / SDA for I ² C mode
U25	P_hdat[8]	B	Host data bit 8
V26	P_hdat[9]	B	Host data bit 9
U26	P_hdat[10]	B	Host data bit 10
R20	P_hdat[11]	B	Host data bit 11
R22	P_hdat[12]	B	Host data bit 12
R23	P_hdat[13]	B	Host data bit 13
R24	P_hdat[14]	B	Host data bit 14
R25	P_hdat[15]	B	Host data bit 15
R26	P_hdat_job	O	Host read data valid signal / HDREQ

TABLE 8. BALL DESCRIPTION OF LCD DRAM INTERFACE

Ball(s) No.	Symbol	Attribute	Description
P22	P_lcd_dram_clk	O	LCD display dram clock out
P23	P_lcd_ma[0]	O	LCD display DRAM control memory address bit 0
P24	P_lcd_ma[1]	O	LCD display DRAM control memory address bit 1
P25	P_lcd_ma[2]	O	LCD display DRAM control memory address bit 2
M26	P_lcd_ma[3]	O	LCD display DRAM control memory address bit 3
M20	P_lcd_ma[4]	O	LCD display DRAM control memory address bit 4
M25	P_lcd_ma[5]	O	LCD display DRAM control memory address bit 5
M24	P_lcd_ma[6]	O	LCD display DRAM control memory address bit 6
M23	P_lcd_ma[7]	O	LCD display DRAM control memory address bit 7
M22	P_lcd_ma[8]	O	LCD display DRAM control memory address bit 8
L21	P_lcd_ma[9]	O	LCD display DRAM control memory address bit 9
L24	P_lcd_ma[10]	O	LCD display DRAM control memory address bit 10
L20	P_lcd_ma[11]	O	LCD display DRAM control memory address bit 11
L23	P_lcd_ba[0]	O	LCD display DRAM control memory bank 0
L22	P_lcd_ba[1]	O	LCD display DRAM control memory bank 1
K26	P_lcd_dq[0]	B	LCD display DRAM control memory data bit 0
J26	P_lcd_dq[1]	B	LCD display DRAM control memory data bit 1

Ball(s) No.	Symbol	Attribute	Description
K25	P_lcd_dq[2]	B	LCD display DRAM control memory data bit 2
H26	P_lcd_dq[3]	B	LCD display DRAM control memory data bit 3
J25	P_lcd_dq[4]	B	LCD display DRAM control memory data bit 4
K24	P_lcd_dq[5]	B	LCD display DRAM control memory data bit 5
G26	P_lcd_dq[6]	B	LCD display DRAM control memory data bit 6
H25	P_lcd_dq[7]	B	LCD display DRAM control memory data bit 7
J24	P_lcd_dq[8]	B	LCD display DRAM control memory data bit 8
K21	P_lcd_dq[9]	B	LCD display DRAM control memory data bit 9
K23	P_lcd_dq[10]	B	LCD display DRAM control memory data bit 10
K20	P_lcd_dq[11]	B	LCD display DRAM control memory data bit 11
G25	P_lcd_dq[12]	B	LCD display DRAM control memory data bit 12
H24	P_lcd_dq[13]	B	LCD display DRAM control memory data bit 13
J23	P_lcd_dq[14]	B	LCD display DRAM control memory data bit 14
K22	P_lcd_dq[15]	B	LCD display DRAM control memory data bit 15
E26	P_lcd_dq[16]	B	LCD display DRAM control memory data bit 16
G24	P_lcd_dq[17]	B	LCD display DRAM control memory data bit 17
H23	P_lcd_dq[18]	B	LCD display DRAM control memory data bit 18
J22	P_lcd_dq[19]	B	LCD display DRAM control memory data bit 19
D26	P_lcd_dq[20]	B	LCD display DRAM control memory data bit 20
E25	P_lcd_dq[21]	B	LCD display DRAM control memory data bit 21
F24	P_lcd_dq[22]	B	LCD display DRAM control memory data bit 22
G23	P_lcd_dq[23]	B	LCD display DRAM control memory data bit 23
J20	P_lcd_dq[24]	B	LCD display DRAM control memory data bit 24
H22	P_lcd_dq[25]	B	LCD display DRAM control memory data bit 25
C26	P_lcd_dq[26]	B	LCD display DRAM control memory data bit 26
D25	P_lcd_dq[27]	B	LCD display DRAM control memory data bit 27
E24	P_lcd_dq[28]	B	LCD display DRAM control memory data bit 28
F23	P_lcd_dq[29]	B	LCD display DRAM control memory data bit 29
G22	P_lcd_dq[30]	B	LCD display DRAM control memory data bit 30
B26	P_lcd_dq[31]	B	LCD display DRAM control memory data bit 31
C25	P_lcd_dq[32]	B	LCD display DRAM control memory data bit 32
D24	P_lcd_dq[33]	B	LCD display DRAM control memory data bit 33
E23	P_lcd_dq[34]	B	LCD display DRAM control memory data bit 34
F22	P_lcd_dq[35]	B	LCD display DRAM control memory data bit 35
C24	P_lcd_dq[36]	B	LCD display DRAM control memory data bit 36
D23	P_lcd_dq[37]	B	LCD display DRAM control memory data bit 37
E22	P_lcd_dq[38]	B	LCD display DRAM control memory data bit 38
H21	P_lcd_dq[39]	B	LCD display DRAM control memory data bit 39
A25	P_lcd_dq[40]	B	LCD display DRAM control memory data bit 40
B24	P_lcd_dq[41]	B	LCD display DRAM control memory data bit 41
C23	P_lcd_dq[42]	B	LCD display DRAM control memory data bit 42
G21	P_lcd_dq[43]	B	LCD display DRAM control memory data bit 43
D22	P_lcd_dq[44]	B	LCD display DRAM control memory data bit 44
G20	P_lcd_dq[45]	B	LCD display DRAM control memory data bit 45
A24	P_lcd_dq[46]	B	LCD display DRAM control memory data bit 46
H20	P_lcd_dq[47]	B	LCD display DRAM control memory data bit 47
B23	P_lcd_dq[48]	B	LCD display DRAM control memory data bit 48
E21	P_lcd_dq[49]	B	LCD display DRAM control memory data bit 49
E20	P_lcd_dq[50]	B	LCD display DRAM control memory data bit 50
G19	P_lcd_dq[51]	B	LCD display DRAM control memory data bit 51
D21	P_lcd_dq[52]	B	LCD display DRAM control memory data bit 52
F20	P_lcd_dq[53]	B	LCD display DRAM control memory data bit 53
C22	P_lcd_dq[54]	B	LCD display DRAM control memory data bit 54
E19	P_lcd_dq[55]	B	LCD display DRAM control memory data bit 55
D20	P_lcd_dq[56]	B	LCD display DRAM control memory data bit 56
C21	P_lcd_dq[57]	B	LCD display DRAM control memory data bit 57
F19	P_lcd_dq[58]	B	LCD display DRAM control memory data bit 58

Ball(s) No.	Symbol	Attribute	Description
B22	P_lcd_dq[59]	B	LCD display DRAM control memory data bit 59
G18	P_lcd_dq[60]	B	LCD display DRAM control memory data bit 60
A23	P_lcd_dq[61]	B	LCD display DRAM control memory data bit 61
E18	P_lcd_dq[62]	B	LCD display DRAM control memory data bit 62
D19	P_lcd_dq[63]	B	LCD display DRAM control memory data bit 63
C20	P_lcd_rasb	0	LCD display DRAM control RASB
A22	P_lcd_casb	0	LCD display DRAM control CASB
G17	P_lcd_web	0	LCD display DRAM control WEB

TABLE 9. BALL DESCRIPTION OF DUAL VIEW PORT INTERFACE

Ball(s) No.	Symbol	Attribute	Description
E10	P_ana_dm_R	0	DualView R / S-Video Y
D9	P_ana_dm_G	0	DualView G / CVBS
C8	P_ana_dm_B	0	DualView B / S-Video C
A8	P_ana_dm_VREF	I	DualView DAC voltage reference (connect to 1.1 VDC)
B8	P_ana_dm_VRO	0	DualView DAC Full-scale Current Adjust Connect 2.7 K Ω (typ) between this pin and Analog GND
B18	P_dm_hsync	0	Dual View Horizontal sync
A19	P_dm_vsync	0	Dual View Vertical sync

TABLE 10. PIN DESCRIPTION OF JTAG PORT INTERFACE

Pin(s) No.	Symbol	Attribute	Description
A7	P_tck	I	JTAG test pin connect to ground
B7	P_tms	I	JTAG test pin connect to ground
A5	P_trst	I	JTAG test pin connect to ground
C7	P_tdi	I	JTAG test pin connect to ground
A4	P_tdo	0	JTAG test pin out

TABLE 11. BALL DESCRIPTION OF MAIN DISPLAY PORT INTERFACE

Ball(s) No.	Symbol	Attribute	Description
B19	P_lcd_hsync	0	LCD Horizontal sync
A20	P_lcd_vsync	0	LCD Vertical sync
E17	P_ana_lcd_R	0	LCD R
C17	P_ana_lcd_G	0	LCD G
C16	P_ana_lcd_B	0	LCD B
A15	P_ana_lcd_VREF	I	LCD DAC voltage reference (connect to 1.1 VDC)
C15	P_ana_lcd_VRO	0	LCD DAC Full-scale Current Adjust Connect 2.7 K Ω (typ) between this pin and Analog GND
D17	P_ana_lcd_R_COM	I	Reserved, no connection
G16	P_ana_lcd_G_COM	I	Reserved, no connection
B15	P_ana_lcd_B_COM	I	Reserved, no connection

TABLE 12. BALL DESCRIPTION OF HDMI PORT INTERFACE

Ball(s) No.	Symbol	Attribute	Description
B14	EXCN	0	HDMI differential clock output
A14	EXCP	0	HDMI differential clock output
A13	EXN0	0	HDMI differential data signal output
B13	EXPO	0	HDMI differential data signal output
B12	EXN1	0	HDMI differential data signal output
A12	EXP1	0	HDMI differential data signal output
A11	EXN2	0	HDMI differential data signal output
B11	EXP2	0	HDMI differential data signal output
A9	P_HTMODE	I	HDMI test mode select, tie to ground
B9	P_HTXRST	I	HDMI reset, tie to 3.3V

Ball(s) No.	Symbol	Attribute	Description
C5	P_I2s_sd[0]	I	HDMI I ² S serial data bit 0, <i>tie to ground if not used</i>
E7	P_I2s_sd[1]	I	HDMI I ² S serial data bit 1, <i>tie to ground if not used</i>
G8	P_I2s_sd[2]	I	HDMI I ² S serial data bit 2, <i>tie to ground if not used</i>
E6	P_I2s_sd[3]	I	HDMI I ² S serial data bit 3, <i>tie to ground if not used</i>
D6	P_I2s_sck	I	HDMI I ² S serial clock, <i>tie to ground if not used</i>
F7	P_I2s_ws	I	HDMI I ² S word select, <i>tie to ground if not used</i>
A17	P_MCLK_I	B	HDMI Audio master clock, <i>tie to ground if not used</i>
F11	P_ASCLK_I	I	HDMI SPDIF capture clock, <i>tie to ground if not used</i>
F14	P_SPDIF_I	I	HDMI S/PDIF audio Input, <i>tie to ground if not used</i>
E14	P_HPD_I	I	HDMI hot plug detect, <i>tie to ground via 10K resistor</i>
A18	P_DSCL	B	HDMI DDC clock pin
B17	P_DSDA	B	HDMI DDC data pin
D14	P_VPD	I	Test power control input, <i>tie to ground</i>

TABLE 13. BALL DESCRIPTION OF MANUFACTURER TEST INTERFACE

Ball(s) No.	Symbol	Attribute	Description
D18	P_test_ena1	I	Test pin1, manufacturer test, <i>tie to ground.</i>
F17	P_test_ena2	I	Test pin2, manufacturer test, <i>tie to ground.</i>

TABLE 14. BALL DESCRIPTION OF PS2 MOUSE PORT INTERFACE

Ball(s) No.	Symbol	Attribute	Description
C4	P_ps2_c	B	PS2 mouse port clock pin
B3	P_ps2_d	B	PS2 mouse port data pin

TABLE 15. BALL DESCRIPTION OF MISCELLANEOUS PORT INTERFACE

Ball(s) No.	Symbol	Attribute	Description
C19	P_trigger_in	I	Ext. Motion detect strobe input, <i>tie to ground if not used</i>
B20	P_irq_out	O	Interrupt to the host
C18	P_mp_out	O	Debugging output, (Multiplexed out of vsync, hsync, or field)
D5	P_ext_clk0	O	Output clock to TW2864 decoder to synchronize data

TABLE 16. BALL DESCRIPTION OF NETWORK PORT INTERFACE

Ball(s) No.	Symbol	Attribute	Description
B5	P_network_clk	O	Network port clock output
C6	P_network_data[0]	O	Network port data output bit 0
F9	P_network_data[1]	O	Network port data output bit 1
D7	P_network_data[2]	O	Network port data output bit 2
G9	P_network_data[3]	O	Network port data output bit 3
E8	P_network_data[4]	O	Network port data output bit 4
A3	P_network_data[5]	O	Network port data output bit 5
B4	P_network_data[6]	O	Network port data output bit 6
F8	P_network_data[7]	O	Network port data output bit 7

TABLE 17. BALL DESCRIPTION OF POWER AND GROUND

Symbol	Ball(s) No.	Voltage	Description
VDD	H9, H10, H13, H14, H17, H18, J8, J11, J12, J15, J16, J19, K8, K10, K13, K14, K17, K19, L9, L18, M9, M18, N8, N10, N17, N19, P8, P10, P17, P19, R9, R18, T9, T18, U8, U10, U13, U14, U17, U19, V8, V11, V12, V15, V16, V19, W9, W10, W14, W17, W18	1.2 Volts	Power of the core logic
VDE	B2, B6, B10, F2, F6, J6, L2, M6, R6, U2, V6, AA2, AA6, AA12, AE2, AE6, AE11, R21, T25, V21, AA15, AA21, AA25, AE16, AE21, AE25, G11, B16, B21, B25, F18, F21, F25, G15, J21, L25, M21	3.3 Volts	Power of the external I/O
VSS	A1, A6, A10, A16, A21, A26, F1, F26, G10, G14, H8, H11, H12, H15, H16, H19, J9, J10, J13, J14, J17, J18, K9, K11, K12, K15, K16, K18, L1, L8, L10, L11, L12, L13, L14, L15, L16, L17, L19, L26, M8, M10, M11, M12, M13, M14, M15, M16, M17, M19, N9, N11, N12, N13, N14, N15, N16, N18, P9, P11, P12, P13, P14, P15, P16, P18, R8, R10, R11, R12, R13, R14, R15, R16, R17, R19, T8, T10, T11, T12, T13, T14, T15, T16, T17, T19, T26, U1, U9, U11, U12, U15, U16, U18, V9, V10, V13, V14, V17, V18, W8, W11, W15, W19, AA1, AA26, AF1, AF6, AF11, AF16, AF21, AF26	-	Ground of the core logic
DAC_DM_R_AVD	D10	3.3 volts	Analog power of DAC for DM R
DAC_DM_G_AVD	C9	3.3 volts	Analog power of DAC for DM G
DAC_DM_B_AVD	E9	3.3 volts	Analog power of DAC for DM B
DAC_LCD_R_AVD	E16	3.3 volts	Analog power of DAC for LCD R
DAC_LCD_G_AVD	F15	3.3 volts	Analog power of DAC for LCD G
DAC_LCD_B_AVD	D15	3.3 volts	Analog power of DAC for LCD B
DAC_SPOT1_AVD	P21	3.3 volts	Analog power of DAC for SOPT1
DAC_SPOT2_AVD	N20	3.3 volts	Analog power of DAC for SOPT2
DAC_SPOT3_AVD	Y12	3.3 volts	Analog power of DAC for SOPT3
DAC_SPOT4_AVD	W13	3.3 volts	Analog power of DAC for SOPT4
DAC_DM_R_AVS	C10	-	Analog ground of DAC for DM R
DAC_DM_G_AVS	F10	-	Analog ground of DAC for DM G
DAC_DM_B_AVS	D8	-	Analog ground of DAC for DM B

Symbol	Ball(s) No.	Voltage	Description
DAC_LCD_R_AVS	F16	-	Analog ground of DAC for LCD R
DAC_LCD_G_AVS	D16	-	Analog ground of DAC for LCD G
DAC_LCD_B_AVS	E15	-	Analog ground of DAC for LCD B
DAC_SPOT1_AVS	P20	-	Analog ground of DAC for SOPT1
DAC_SPOT2_AVS	N21	-	Analog ground of DAC for SOPT2
DAC_SPOT3_AVS	W12	-	Analog ground of DAC for SOPT3
DAC_SPOT4_AVS	Y13	-	Analog ground of DAC for SOPT4
MCK_PLL_AVD	T3	1.2 Volts	Analog power of the MCK PLL
VCK_PLL_AVD	T4	1.2 Volts	Analog power of the VCK PLL
SCK_PLL_AVD	T5	1.2 Volts	Analog power of the SCK PLL
MCK_PLL_AVS	U3	-	Analog ground of the MCK PLL
VCK_PLL_AVS	U4	-	Analog ground of the VCK PLL
SCK_PLL_AVS	U5	-	Analog ground of the SCK PLL
HDMI_VDN	C11, C13, E11, F12, G13	1.2 volts	Analog power of the HDMI core
HDMI_VDP1	D13	3.3 volts	Analog power of the HDMI I/O
HDMI_VDP2	D12	3.3 volts	Analog power of the HDMI I/O
HDMI_VDU	E13	1.2 volts	Analog power of HDMI PLL
HDMI_VSN	C12, C14, D11, E12, F13, G12,	-	Analog ground of the HDMI

Ball Diagrams

	1	2	3	4	5	6	7	8	9	10	11	12	13	14	15	16	17	18	19	20	21	22	23	24	25	26				
A	VSS	P_ckin12	P_network_data[5]	P_tdo	P_trst	VSS	P_tck	P_ana_d_m_VREF	P_HTMODE	VSS	EXN2	EXP1	EXN0	EXCP	P_ana_d_m_VREF	VSS	P_MCLK1	P_DSCL	P_dm_vsync	P_lod_vsync	VSS	P_lod_casb	P_lod_dq[61]	P_lod_dq[46]	P_lod_dq[40]	VSS	A			
B	P_din[4]	VDE	P_ps2_d	P_network_data[6]	P_network_ck	VDE	P_tms	P_ana_d_m_VRO	P_HTXRS_T	VDE	EXP2	EXN1	EXP0	EXCN	P_ana_d_m_VRO	VDE	P_DSDA	P_dm_hsync	P_lod_hsync	P_irq_out	VDE	P_lod_dq[59]	P_lod_dq[48]	P_lod_dq[41]	VDE	P_lod_dq[31]	B			
C	P_din[2]	P_din[5]	P_din[10]	P_ps2_d	P_l2s_sd[0]	P_network_data[0]	P_sj	P_ana_d_m_B	DAC_DM_G_AVD	DAC_DM_R_AVD	HDMI_VD_A	HDMI_VS_N	HDMI_VD_B	HDMI_VS_P	P_ana_d_m_VRO	P_ana_d_m_B	P_ana_d_m_G	P_ana_d_m_R	P_ana_d_m_G	P_ana_d_m_R	P_irq_out	P_trigger_in	P_lod_rasb	P_lod_dq[57]	P_lod_dq[54]	P_lod_dq[42]	P_lod_dq[38]	P_lod_dq[32]	P_lod_dq[26]	C
D	P_din[3]	P_din[2]	P_din[18]	P_din[11]	P_ext_clk_o	P_l2s_sd[3]	P_network_data[2]	DAC_DM_B_AVD	P_ana_d_m_G	DAC_DM_R_AVD	HDMI_VS_N	HDMI_VD_P2	HDMI_VD_P1	P_VPD	DAC_LCD_B_AVD	DAC_LCD_G_AVD	DAC_LCD_R_AVD	P_ana_d_m_R	P_test_en_a1	P_lod_dq[63]	P_lod_dq[56]	P_lod_dq[52]	P_lod_dq[44]	P_lod_dq[37]	P_lod_dq[33]	P_lod_dq[27]	P_lod_dq[20]	D		
E	P_din[5]	P_din[3]	P_din[25]	P_din[7]	P_din[12]	P_l2s_sd[1]	P_network_data[4]	DAC_DM_B_AVD	P_ana_d_m_R	HDMI_VD_A	HDMI_VS_N	HDMI_VD_U	P_HPD_J	DAC_LCD_B_AVD	DAC_LCD_G_AVD	DAC_LCD_R_AVD	P_ana_d_m_R	P_lod_wb	P_lod_dq[62]	P_lod_dq[55]	P_lod_dq[50]	P_lod_dq[49]	P_lod_dq[38]	P_lod_dq[34]	P_lod_dq[28]	P_lod_dq[21]	P_lod_dq[16]	E		
F	VSS	VDE	P_din[3]	P_din[6]	P_din[20]	VDE	P_l2s_ws	P_network_data[7]	P_network_data[1]	DAC_DM_G_AVD	P_ASCLK	HDMI_VD_A	HDMI_VS_N	P_SPOIF_J	DAC_LCD_G_AVD	DAC_LCD_R_AVD	P_test_en_a2	VDE	P_lod_dq[58]	P_lod_dq[53]	VDE	P_lod_dq[35]	P_lod_dq[29]	P_lod_dq[22]	VDE	VSS	F			
G	P_din[3]	P_din[4]	P_din[36]	P_din[3]	P_din[27]	P_din[21]	P_din[13]	P_l2s_sd[2]	P_network_data[3]	VSS	VDE	HDMI_VS_N	HDMI_VD_N	VSS	VDE	P_ana_d_m_CO M	P_lod_wb	P_lod_dq[60]	P_lod_dq[51]	P_lod_dq[45]	P_lod_dq[43]	P_lod_dq[30]	P_lod_dq[23]	P_lod_dq[17]	P_lod_dq[12]	P_lod_dq[6]	G			
H	P_din[6]	P_din[4]	P_din[42]	P_din[37]	P_din[34]	P_ckin34	P_din[24]	VSS	VDD	VDD	VSS	VSS	VDD	VDD	VSS	VSS	VDD	VDD	VSS	VSS	VDD	VSS	P_lod_dq[47]	P_lod_dq[39]	P_lod_dq[25]	P_lod_dq[18]	P_lod_dq[13]	P_lod_dq[7]	H	
J	P_din[5]	P_din[54]	P_ckin56	P_din[5]	P_din[40]	VDE	P_din[7]	VDD	VSS	VSS	VDD	VDD	VSS	VSS	VDD	VDD	VSS	VSS	VDD	VSS	VDD	VDE	P_lod_dq[19]	P_lod_dq[14]	P_lod_dq[8]	P_lod_dq[4]	P_lod_dq[1]	J		
K	P_din[2]	P_din[6]	P_din[60]	P_din[57]	P_din[56]	P_din[51]	P_din[50]	VDD	VSS	VDD	VSS	VSS	VDD	VDD	VSS	VSS	VDD	VSS	VDD	VSS	VDD	P_lod_dq[11]	P_lod_dq[9]	P_lod_dq[15]	P_lod_dq[10]	P_lod_dq[5]	P_lod_dq[2]	K		
L	VSS	VDE	P_din[6]	P_din[64]	P_din[63]	P_din[53]	P_din[52]	VSS	VDD	VSS	VSS	VSS	VSS	VSS	VSS	VSS	VSS	VSS	VDD	VSS	VDD	P_lod_ma[11]	P_lod_ma[9]	P_lod_ma[1]	P_lod_ma[0]	VDE	VSS	L		
M	P_din[7]	P_din[71]	P_din[70]	P_ckin78	P_din[6]	VDE	P_din[7]	VSS	VDD	VSS	VSS	VSS	VSS	VSS	VSS	VSS	VSS	VSS	VSS	VDD	VSS	P_lod_ma[4]	VDE	P_lod_ma[8]	P_lod_ma[7]	P_lod_ma[6]	P_lod_ma[5]	P_lod_ma[3]	M	
N	P_din[8]	P_din[80]	P_din[77]	P_din[76]	P_din[75]	P_din[73]	P_din[74]	VDD	VSS	VDD	VSS	VSS	VSS	VSS	VSS	VSS	VSS	VSS	VDD	VSS	VDD	DAC_SP_OT2_AVD	DAC_SP_OT1_AVD	P_ana_sp_ot1_VRO	P_ana_sp_ot2_CVBS	P_ana_sp_ot2_VREF	P_ana_sp_ot2_VRO	N		
P	P_din[2]	P_din[83]	P_din[84]	P_din[86]	P_din[87]	P_din[85]	P_ck27pb1	VDD	VSS	VDD	VSS	VSS	VSS	VSS	VSS	VSS	VDD	VSS	VDD	VSS	VDD	DAC_SP_OT1_AVD	DAC_SP_OT2_AVD	P_lod_ma[6]	P_lod_ma[0]	P_lod_ma[2]	P_lod_ma[5]	P_ana_sp_ot1_VREF	P	
R	P_din_pb[10]	P_din_pb[11]	P_din_pb[12]	P_din_pb[13]	P_din_pb[15]	VDE	P_din_pb[14]	VSS	VDD	VSS	VSS	VSS	VSS	VSS	VSS	VSS	VSS	VSS	VDD	VSS	VDD	P_hdat[11]	VDE	P_hdat[12]	P_hdat[13]	P_hdat[14]	P_hdat[15]	P_hdat_io_b	R	
T	P_xtal_in1	P_xtal_in2	MCK_PLL_AVD	VCK_PLL_AVD	SCK_PLL_AVD	P_din_pb[17]	VSS	VDD	VSS	VSS	VSS	VSS	VSS	VSS	VSS	VSS	VSS	VSS	VDD	VSS	VDD	P_hdat[8]	P_hdat[10]	P_hdat[9]	P_hdat[3]	P_hdat[7]	VDE	VSS	T	
U	VSS	VDE	MCK_PLL_AVD	VCK_PLL_AVD	SCK_PLL_AVD	P_ck27pb2	P_din_pb[26]	VDD	VSS	VDD	VSS	VSS	VDD	VDD	VSS	VSS	VSS	VDD	VSS	VDD	VSS	P_hdat[2]	P_hdat[4]	P_hdat[3]	P_hdat[1]	P_hdat[4]	P_hdat[8]	P_hdat[10]	U	
V	P_din_pb[20]	P_din_pb[21]	P_din_pb[22]	P_din_pb[23]	P_din_pb[25]	VDE	P_bt601_H1	VDD	VSS	VSS	VDD	VDD	VSS	VSS	VDD	VDD	VSS	VSS	VDD	VSS	VDD	P_hsb	VDE	P_hwb	P_hdat[5]	P_hdat[0]	P_hdat[5]	P_hdat[9]	V	
W	P_din_pb[24]	P_din_pb[27]	P_ck27pb3	P_din_pb[32]	P_ck27pb4	P_bt601_V2	P_rec1_enc_data[1]	VSS	VDD	VDD	VSS	DAC_SP_OT3_AVD	DAC_SP_OT4_AVD	VDD	VSS	P_rec_dq[18]	VDD	VDD	VSS	VSS	VDD	P_rec_dq[52]	P_rec_dq[56]	P_rec_dq[63]	P_hrb	P_hdat[6]	P_hdat[1]	P_hdat[6]	W	
Y	P_bt601_V1	P_din_pb[30]	P_din_pb[31]	P_din_pb[37]	P_din_pb[44]	P_rec1_clk	P_rec1_enc_data[7]	P_rec2_enc_data[3]	P_rec3_enc_data[0]	P_rec3_enc_data[6]	P_rec3_bt601_H3	P_rec4_enc_data[8]	DAC_SP_OT3_AVD	DAC_SP_OT4_AVD	P_rec_ma[9]	P_rec_dq[3]	P_rec_dq[16]	P_rec_dq[24]	P_rec_dq[30]	P_rec_dq[45]	P_rec_dq[47]	P_rec_dq[54]	P_rec_dq[57]	P_rab	P_hdat[7]	P_hdat[7]	P_hdat[2]	Y		
AA	VSS	VDE	P_din_pb[36]	P_din_pb[43]	P_rec1_enc_data[2]	VDE	P_rec1_bt601_H1	P_rec2_enc_data[5]	P_rec3_enc_data[4]	P_rec3_enc_data[9]	P_rec4_bt601_H4	VDE	P_rec_ma[0]	P_rec_ma[7]	VDE	P_rec_dq[11]	P_rec_dq[22]	P_rec_dq[28]	P_rec_dq[39]	P_rec_dq[43]	VDE	P_rec_dq[50]	P_rec_dq[59]	P_wait_st	VDE	VSS	AA			
AB	P_din_pb[33]	P_din_pb[35]	P_din_pb[42]	P_rec1_clk	P_rec1_enc_data[3]	P_rec1_bt601_V1	P_rec2_clk	P_rec2_enc_data[6]	P_rec3_enc_data[1]	P_rec3_enc_data[8]	P_rec3_bt601_F2	P_rec3_bt601_F3	P_rec4_enc_data[3]	P_rec4_enc_data[6]	P_ana_sp_ot3_VRO	P_ana_sp_ot4_CVBS	P_rec_ma[11]	P_rec_dq[5]	P_rec_dq[15]	P_rec_dq[23]	P_rec_dq[29]	P_rec_dq[33]	P_rec_dq[38]	P_rec_dq[49]	P_rec_dq[51]	P_rec_dq[60]	P_h16b_en	P_hdat[1]	AB	
AC	P_din_pb[34]	P_din_pb[41]	P_din_pb[47]	P_rec1_enc_data[0]	P_rec1_bt601_F1	P_rec2_clk	P_rec2_enc_data[4]	P_rec3_clk	P_rec3_enc_data[2]	P_rec3_enc_data[7]	P_rec4_clk	P_rec4_enc_data[5]	P_ana_sp_ot3_VREF	P_rec_ma[10]	P_rec_ma[16]	P_rec_dq[4]	P_rec_dq[10]	P_rec_dq[17]	P_rec_dq[25]	P_rec_dq[31]	P_rec_dq[39]	P_rec_dq[44]	P_rec_dq[40]	P_rec_dq[48]	P_rec_dq[53]	P_rec_dq[61]	P_hspb	AC		
AD	P_din_pb[40]	P_din_pb[46]	P_bt601_H2	P_rec1_enc_data[4]	P_rec2_enc_data[0]	P_rec2_enc_data[5]	P_rec3_clk	P_rec3_enc_data[3]	P_rec3_enc_data[8]	P_rec4_clk	P_rec4_enc_data[6]	P_rec4_enc_data[9]	P_ana_sp_ot3_CVBS	P_rec_ma[2]	P_rec_ma[8]	P_rec_dq[2]	P_rec_dq[7]	P_rec_dq[12]	P_rec_dq[19]	P_rec_dq[26]	P_rec_dq[35]	P_rec_dq[0]	P_rec_dq[35]	P_rec_dq[41]	P_rec_dq[46]	P_rec_dq[55]	P_rec_dq[62]	AD		
AE	P_din_pb[45]	VDE	P_rec1_enc_data[5]	P_rec2_enc_data[1]	P_rec2_enc_data[7]	VDE	P_rec3_enc_data[5]	P_rec3_enc_data[7]	P_rec4_enc_data[1]	P_rec4_enc_data[7]	VDE	P_ana_sp_ot4_VREF	P_rec_ma[3]	P_rec_ma[6]	P_rec_dq[1]	VDE	P_rec_dq[8]	P_rec_dq[13]	P_rec_dq[20]	P_rec_dq[27]	VDE	P_rec_dq[1]	P_rec_dq[36]	P_rec_dq[42]	VDE	P_rec_dq[56]	AE			
AF	VSS	P_rec1_enc_data[2]	P_rec2_bt601_H2	P_rec2_bt601_V2	VSS	P_rec2_bt601_V3	P_rec3_bt601_V3	P_rec4_bt601_V4	P_rec4_bt601_F4	VSS	P_ana_sp_ot4_VRO	P_rec_ma[4]	P_rec_ma[5]	P_rec_dq[0]	VSS	P_rec_dq[6]	P_rec_dq[9]	P_rec_dq[14]	P_rec_dq[21]	VSS	P_rec_dq[21]	P_rec_dq[32]	P_rec_dq[37]	P_rec_dq[44]	VSS	AF				

FIGURE 1. MAP OF ALL THE TW2880 SIGNAL POSITIONS

	1	2	3	4	5	6	7	8	9	10	11	12	13
A	VSS	P_ckvin12	P_network_data[5]	P_tdo	P_trst	VSS	P_tck	P_ana_d m_VREF	P_HTMO DE	VSS	EXN2	EXP1	EXN0
B	P_din1[4]	VDE	P_ps2_d	P_network_data[6]	P_network_clk	VDE	P_tms	P_ana_d m_VRO	P_HTXRS T	VDE	EXP2	EXN1	EXP0
C	P_din2[2]	P_din1[5]	P_din1[0]	P_ps2_c	P_i2s_sd[0]	P_network_data[0]	P_tdi	P_ana_d m_B	DAC_DM G_AVD	DAC_DM R_AVS	HDMI_VD N	HDMI_VS N	HDMI_VD N
D	P_din3[0]	P_din2[3]	P_din1[6]	P_din1[1]	P_ext_clk o	P_i2s_sck	P_network_data[2]	DAC_DM B_AVS	P_ana_d m_G	DAC_DM R_AVD	HDMI_VS N	HDMI_VD P2	HDMI_VD P1
E	P_din3[5]	P_din3[1]	P_din2[5]	P_din1[7]	P_din1[2]	P_i2s_sd[3]	P_i2s_sd[1]	P_network_data[4]	DAC_DM B_AVD	P_ana_d m_R	HDMI_VD N	HDMI_VS N	HDMI_VD U
F	VSS	VDE	P_din3[2]	P_din2[6]	P_din2[0]	VDE	P_i2s_ws	P_network_data[7]	P_network_data[1]	DAC_DM G_AVS	P_ASCLK _I	HDMI_VD N	HDMI_VS N
G	P_din4[3]	P_din4[1]	P_din3[6]	P_din3[3]	P_din2[7]	P_din2[1]	P_din1[3]	P_i2s_sd[2]	P_network_data[3]	VSS	VDE	HDMI_VS N	HDMI_VD N
H	P_din4[6]	P_din4[4]	P_din4[2]	P_din3[7]	P_din3[4]	P_ckvin34	P_din2[4]	VSS	VDD	VDD	VSS	VSS	VDD
J	P_din5[5]	P_din5[4]	P_ckvin56	P_din4[5]	P_din4[0]	VDE	P_din4[7]	VDD	VSS	VSS	VDD	VDD	VSS
K	P_din6[2]	P_din6[1]	P_din6[0]	P_din5[7]	P_din5[6]	P_din5[1]	P_din5[0]	VDD	VSS	VDD	VSS	VSS	VDD
L	VSS	VDE	P_din6[5]	P_din6[4]	P_din6[3]	P_din5[3]	P_din5[2]	VSS	VDD	VSS	VSS	VSS	VSS
M	P_din7[2]	P_din7[1]	P_din7[0]	P_ckvin78	P_din6[6]	VDE	P_din6[7]	VSS	VDD	VSS	VSS	VSS	VSS
N	P_din8[1]	P_din8[0]	P_din7[7]	P_din7[6]	P_din7[5]	P_din7[3]	P_din7[4]	VDD	VSS	VDD	VSS	VSS	VSS

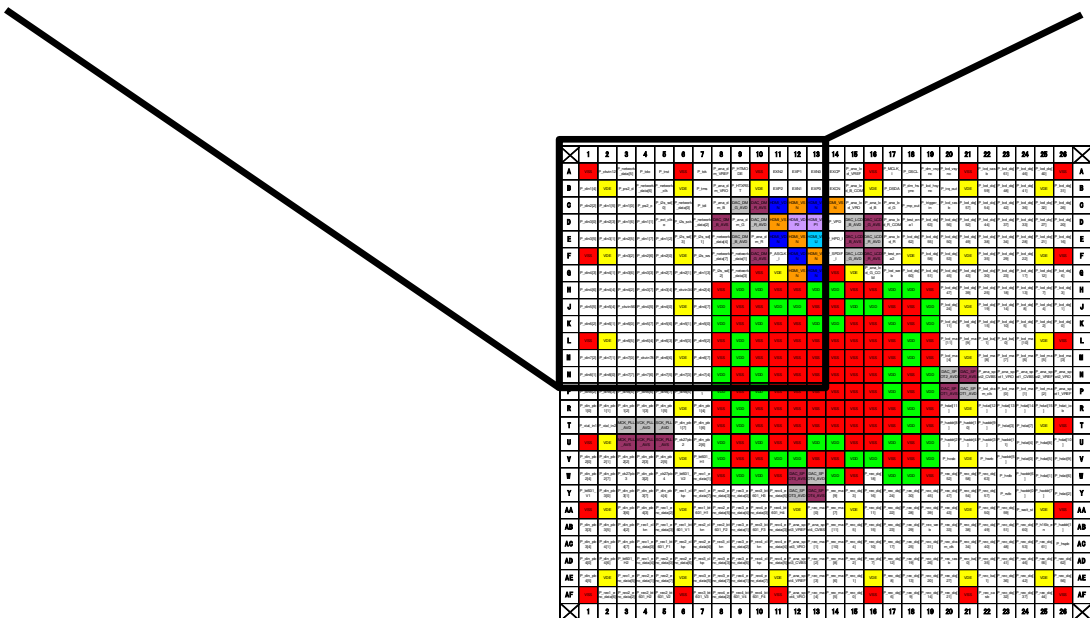

FIGURE 2. MAP OF THE UPPER-LEFT QUADRANT

	14	15	16	17	18	19	20	21	22	23	24	25	26	
EXCP	P_ana_lcd_VREF	VSS	P_MCLK_I	P_DSCL	P_dm_hsync	P_lcd_vsync	VSS	P_lcd_casb	P_lcd_dq[61]	P_lcd_dq[46]	P_lcd_dq[40]	VSS	A	
EXCN	P_ana_lcd_B_COM	VDE	P_DSDA	P_dm_hsync	P_lcd_hsync	P_irq_out	VDE	P_lcd_dq[59]	P_lcd_dq[48]	P_lcd_dq[41]	VDE	P_lcd_dq[31]	B	
HDMI_VSN	P_ana_lcd_VRO	P_ana_lcd_B	P_ana_lcd_G	P_mp_out	P_trigger_in	P_lcd_rasb	P_lcd_dq[57]	P_lcd_dq[54]	P_lcd_dq[42]	P_lcd_dq[36]	P_lcd_dq[32]	P_lcd_dq[26]	C	
P_VPD	DAC_LCD_B_AVD	DAC_LCD_G_AVS	P_ana_lcd_R_COM	P_test_ena1	P_lcd_dq[63]	P_lcd_dq[56]	P_lcd_dq[52]	P_lcd_dq[44]	P_lcd_dq[37]	P_lcd_dq[33]	P_lcd_dq[27]	P_lcd_dq[20]	D	
P_HPD_I	DAC_LCD_B_AVS	DAC_LCD_R_AVD	P_ana_lcd_R	P_lcd_dq[62]	P_lcd_dq[55]	P_lcd_dq[50]	P_lcd_dq[49]	P_lcd_dq[38]	P_lcd_dq[34]	P_lcd_dq[28]	P_lcd_dq[21]	P_lcd_dq[16]	E	
P_SPDIF_I	DAC_LCD_G_AVD	DAC_LCD_R_AVS	P_test_ena2	VDE	P_lcd_dq[58]	P_lcd_dq[53]	VDE	P_lcd_dq[35]	P_lcd_dq[29]	P_lcd_dq[22]	VDE	VSS	F	
VSS	VDE	P_ana_lcd_G_COM	P_lcd_web	P_lcd_dq[60]	P_lcd_dq[51]	P_lcd_dq[45]	P_lcd_dq[43]	P_lcd_dq[30]	P_lcd_dq[23]	P_lcd_dq[17]	P_lcd_dq[12]	P_lcd_dq[6]	G	
VDD	VSS	VSS	VDD	VDD	VSS	P_lcd_dq[47]	P_lcd_dq[39]	P_lcd_dq[25]	P_lcd_dq[18]	P_lcd_dq[13]	P_lcd_dq[7]	P_lcd_dq[3]	H	
VSS	VDD	VDD	VSS	VSS	VDD	P_lcd_dq[24]	VDE	P_lcd_dq[19]	P_lcd_dq[14]	P_lcd_dq[8]	P_lcd_dq[4]	P_lcd_dq[1]	J	
VDD	VSS	VSS	VDD	VSS	VDD	P_lcd_dq[11]	P_lcd_dq[9]	P_lcd_dq[15]	P_lcd_dq[10]	P_lcd_dq[5]	P_lcd_dq[2]	P_lcd_dq[0]	K	
VSS	VSS	VSS	VSS	VDD	VSS	P_lcd_ma[11]	P_lcd_ma[9]	P_lcd_ba[1]	P_lcd_ba[0]	P_lcd_ma[10]	VDE	VSS	L	
VSS	VSS	VSS	VSS	VDD	VSS	P_lcd_ma[4]	VDE	P_lcd_ma[8]	P_lcd_ma[7]	P_lcd_ma[6]	P_lcd_ma[5]	P_lcd_ma[3]	M	
VSS	VSS	VSS	VDD	VSS	VDD	DAC_SPOT2_AVD	DAC_SPOT2_AVS	P_ana_spot2_CVBS	P_ana_spot1_VRO	P_ana_spot1_CVBS	P_ana_spot2_VREF	P_ana_spot2_VRO	N	

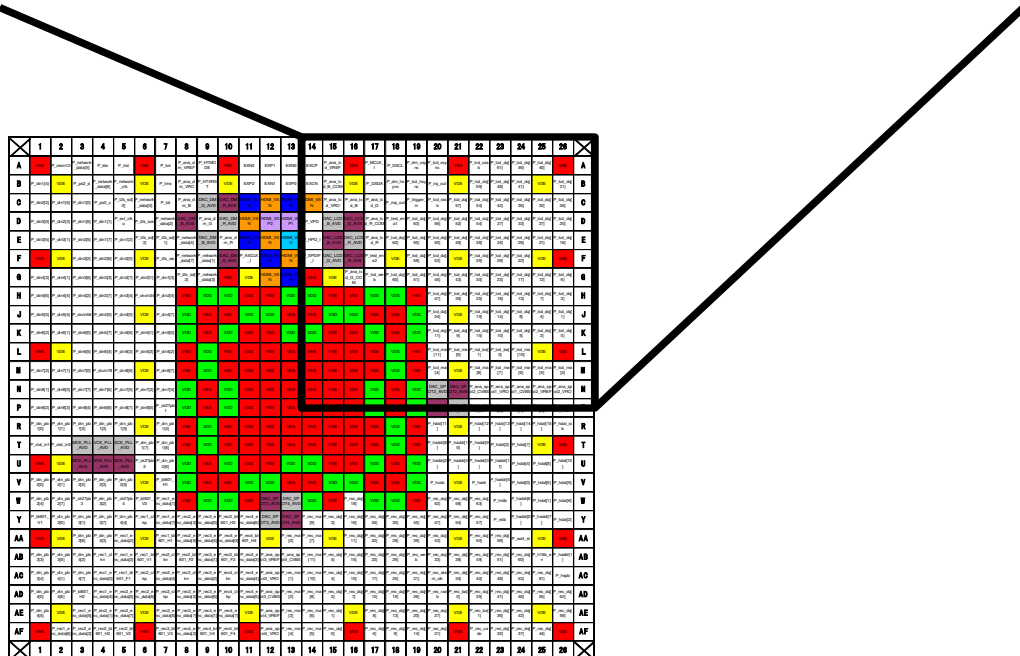
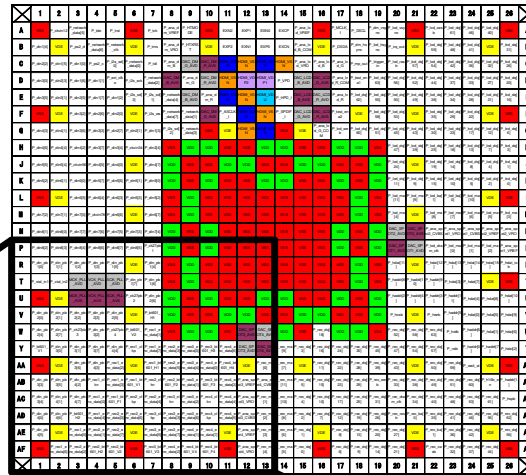

FIGURE 3. MAP OF THE UPPER-RIGHT QUADRANT

VSS	VSS	VSS	VDD	VSS	VDD	DAC_SP OT1_AVSS	DAC_SP OT1_AVDD	P_lcd_dra m_clk	P_lcd_ma [0]	P_lcd_ma [1]	P_lcd_ma [2]	P_ana_sp ot1_VREF	P
VSS	VSS	VSS	VSS	VDD	VSS	P_hdat[11]	VDE	P_hdat[12]	P_hdat[13]	P_hdat[14]	P_hdat[15]	P_hdat_io b	R
VSS	VSS	VSS	VSS	VDD	VSS	P_haddr[8]	P_haddr[1 0]	P_haddr[9]	P_hdat[3]	P_hdat[7]	VDE	VSS	T
VDD	VSS	VSS	VDD	VSS	VDD	P_haddr[2]	P_haddr[4]	P_haddr[3]	P_haddr[1]	P_hdat[4]	P_hdat[8]	P_hdat[10]	U
VSS	VDD	VDD	VSS	VSS	VDD	P_hcsb	VDE	P_hwrb	P_haddr[5]	P_hdat[0]	P_hdat[5]	P_hdat[9]	V
VDD	VSS	P_rec_dq[18]	VDD	VDD	VSS	P_rec_dq[52]	P_rec_dq[58]	P_rec_dq[63]	P_hrdb	P_haddr[6]	P_hdat[1]	P_hdat[6]	W
P_rec_ma [9]	P_rec_dq[3]	P_rec_dq[16]	P_rec_dq[24]	P_rec_dq[30]	P_rec_dq[45]	P_rec_dq[47]	P_rec_dq[54]	P_rec_dq[57]	P_rstb	P_haddr[0]	P_haddr[7]	P_hdat[2]	Y
P_rec_ma [7]	VDE	P_rec_dq[11]	P_rec_dq[22]	P_rec_dq[28]	P_rec_dq[39]	P_rec_dq[43]	VDE	P_rec_dq[50]	P_rec_dq[59]	P_wait_st	VDE	VSS	AA
P_rec_ma [11]	P_rec_dq[5]	P_rec_dq[15]	P_rec_dq[23]	P_rec_dq[29]	P_rec_we b	P_rec_dq[33]	P_rec_dq[38]	P_rec_dq[49]	P_rec_dq[51]	P_rec_dq[60]	P_h16b_e n	P_haddr[1]	AB
P_rec_ma [10]	P_rec_dq[4]	P_rec_dq[10]	P_rec_dq[17]	P_rec_dq[25]	P_rec_dq[31]	P_rec_dra m_clk	P_rec_dq[34]	P_rec_dq[40]	P_rec_dq[48]	P_rec_dq[53]	P_rec_dq[61]	P_hspb	AC
P_rec_ma [8]	P_rec_dq[2]	P_rec_dq[7]	P_rec_dq[12]	P_rec_dq[19]	P_rec_dq[26]	P_rec_ras b	P_rec_ba[0]	P_rec_dq[35]	P_rec_dq[41]	P_rec_dq[46]	P_rec_dq[55]	P_rec_dq[62]	AD
P_rec_ma [6]	P_rec_dq[1]	VDE	P_rec_dq[8]	P_rec_dq[13]	P_rec_dq[20]	P_rec_dq[27]	VDE	P_rec_ba[1]	P_rec_dq[36]	P_rec_dq[42]	VDE	P_rec_dq[56]	AE
P_rec_ma [5]	P_rec_dq[0]	VSS	P_rec_dq[6]	P_rec_dq[9]	P_rec_dq[14]	P_rec_dq[21]	VSS	P_rec_ca sb	P_rec_dq[32]	P_rec_dq[37]	P_rec_dq[44]	VSS	AF
14	15	16	17	18	19	20	21	22	23	24	25	26	X

FIGURE 4. MAP OF THE LOWER-RIGHT QUADRANT



P	P_din8[2]	P_din8[3]	P_din8[4]	P_din8[6]	P_din8[7]	P_din8[5]	P_ck27pb1	VDD	VSS	VDD	VSS	VSS	VSS
R	P_din_pb1[0]	P_din_pb1[1]	P_din_pb1[2]	P_din_pb1[3]	P_din_pb1[5]	VDE	P_din_pb1[4]	VSS	VDD	VSS	VSS	VSS	VSS
T	P_xtal_in1	P_xtal_in2	MCK_PLL_AVD	VCK_PLL_AVD	SCK_PLL_AVD	P_din_pb1[7]	P_din_pb1[6]	VSS	VDD	VSS	VSS	VSS	VSS
U	VSS	VDE	MCK_PLL_AVS	VCK_PLL_AVS	SCK_PLL_AVS	P_ck27pb2	P_din_pb2[6]	VDD	VSS	VDD	VSS	VSS	VDD
V	P_din_pb2[0]	P_din_pb2[1]	P_din_pb2[2]	P_din_pb2[3]	P_din_pb2[5]	VDE	P_bt601_H1	VDD	VSS	VSS	VDD	VDD	VSS
W	P_din_pb2[4]	P_din_pb2[7]	P_ck27pb3	P_din_pb3[2]	P_ck27pb4	P_bt601_V2	P_rec1_anc_data[1]	VSS	VDD	VDD	VSS	DAC_SP_OT3_AV3	DAC_SP_OT4_AV4
Y	P_bt601_V1	P_din_pb3[0]	P_din_pb3[1]	P_din_pb3[7]	P_din_pb4[4]	P_rec1_clkp	P_rec1_anc_data[7]	P_rec2_anc_data[3]	P_rec3_anc_data[0]	P_rec3_bt601_H3	P_rec4_anc_data[6]	DAC_SP_OT3_AV3	DAC_SP_OT4_AV4
AA	VSS	VDE	P_din_pb3[6]	P_din_pb4[3]	P_rec1_anc_data[2]	VDE	P_rec1_bt601_H1	P_rec2_anc_data[5]	P_rec3_anc_data[4]	P_rec4_anc_data[0]	P_rec4_bt601_H4	VDE	P_rec_ma[0]
AB	P_din_pb3[3]	P_din_pb3[5]	P_din_pb4[2]	P_rec1_anc_data[3]	P_rec1_anc_data[3]	P_rec1_bt601_V1	P_rec2_anc_data[kn]	P_rec2_bt601_F2	P_rec3_anc_data[1]	P_rec3_bt601_F3	P_rec4_anc_data[3]	P_ana_spot3_VREF	P_ana_spot4_CVBS
AC	P_din_pb3[4]	P_din_pb4[1]	P_din_pb4[7]	P_rec1_anc_data[0]	P_rec1_anc_data[0]	P_rec2_anc_data[kn]	P_rec2_anc_data[4]	P_rec3_anc_data[kn]	P_rec3_anc_data[2]	P_rec4_anc_data[kn]	P_rec4_anc_data[4]	P_ana_spot3_VRO	P_rec_ma[1]
AD	P_din_pb4[0]	P_din_pb4[6]	P_bt601_H2	P_rec1_anc_data[4]	P_rec2_anc_data[0]	P_rec2_anc_data[6]	P_rec3_anc_data[3]	P_rec3_anc_data[3]	P_rec3_anc_data[6]	P_rec4_anc_data[kn]	P_rec4_anc_data[5]	P_ana_spot3_CVBS	P_rec_ma[2]
AE	P_din_pb4[5]	VDE	P_rec1_anc_data[5]	P_rec2_anc_data[1]	P_rec2_anc_data[7]	VDE	P_rec3_anc_data[5]	P_rec3_anc_data[7]	P_rec4_anc_data[1]	P_rec4_anc_data[7]	VDE	P_ana_spot4_VREF	P_rec_ma[3]
AF	VSS	P_rec1_anc_data[6]	P_rec2_anc_data[2]	P_rec2_bt601_H2	P_rec2_bt601_V2	VSS	P_rec3_bt601_V3	P_rec4_anc_data[2]	P_rec4_bt601_V4	P_rec4_bt601_F4	VSS	P_ana_spot4_VRO	P_rec_ma[4]
X	1	2	3	4	5	6	7	8	9	10	11	12	13

FIGURE 5. MAP OF THE LOWER-LEFT QUADRANT

AC/DC Electrical Parameters

ABSOLUTE MAXIMUM RATINGS

PARAMETER	SYMBOL	MIN	TYP	MAX	UNITS
DAC AVD	DAC_VDD	-0.5	3.3	3.6	V
Vref	VREF_VDD	-0.5	1.1	1.3	V
PLL AVD	PLL_VDD	-0.5	1.2	1.8	V
HDMI AVD	HDMI_VDD	-0.5	3.3	3.6	V
VDD 1.2V	VDD	-0.5	1.2	1.8	V
VDD 3.3V	VDE	-0.5	3.3	4.6	V
Voltage on Any Digital Data Pin (See Caution statement)	-	-0.5	-	3.8	V
Voltage on OSC Related Analog Pin	-	-0.5	-	3.8	V
Storage Temperature	T _s	-55	-	125	°C
Junction Temperature	T _j	-40	-	125	°C
Reflow Soldering (≤ 10 Seconds)	T _{PEAK}	-	-	240 - 250	°C

CAUTION: Do not operate at or near the maximum ratings listed for extended periods of time. Exposure to such conditions may adversely impact product reliability and result in failures not covered by warranty.

RECOMMENDED OPERATING CONDITIONS

PARAMETER	SYMBOL	MIN	TYP	MAX	UNITS
DAC AVD (measured to VSSDAC)		2.7	3.3	3.6	V
Vref		1.05	1.1	1.15	V
PLL AVD (measured to VSSPLL)		1.15	1.2	1.3	V
HDMI VDP		3.0	3.3	3.6	V
HDMI VDN,VDU		1.15	1.2	1.3	V
VDD (measured to VSS)		1.15	1.2	1.3	V
VDDO (measured to VSSO)		3.0	3.3	3.6	V
Ambient Operating Temperature	T _A	0	25	70	°C

SUPPLY CURRENT AND POWER DISSIPATION

PARAMETER	SYMBOL	MIN (NOTE 1)	TYP	MAX (NOTE 1)	UNITS
PLL Supply Current (1.2V nom)	I _{DDP}	14	15.6	17	mA
DAC Supply Current (3.3V nom)	I _{DDD}	280	280	285	mA
HDMI Analog Supply Current (1.2V nom)	I _{DDH}	26.8	28.4	30.3	mA
HDMI Digital Supply Current (1.2V nom)	I _{DDH}	11.3	12.36	13.8	mA

PARAMETER	SYMBOL	MIN (NOTE 1)	TYP	MAX (NOTE 1)	UNITS
Digital Internal Supply Current (1.2V nom)	I _{DDI}	490	540	610	mA
Digital I/O Supply Current (3.3V nom)	I _{DDO}	110	140	150	mA
Total Power Dissipation	P _d	1.81	2.16	2.5	W

PLL AC PARAMETERS

PARAMETER	SYMBOL	MIN (NOTE 1)	TYP	MAX (NOTE 1)	UNITS
Period Jitter	T _{jit} (per)	—	±0.01 / F _{out} (Hz)	±0.025 / F _{out} (Hz)	(P-P) s
Phase Jitter	T _{jit} (φ)	—	—	±150	(P-P) ps
Phase Skew	T _{pskew}	—	—	±400	(P-P) ps
Look up Time	T _L	—	—	250	μs
Duty Cycle	O _{dc}	40	50	60	%

DC CHARACTERISTICS

PARAMETER	SYMBOL	MIN (NOTE 1)	TYP	MAX (NOTE 1)	UNITS
Digital Inputs					
Input High Voltage (TTL)	V _{IH}	2.0	—	V _{DDE} + 0.3	V
Input Low Voltage (TTL)	V _{IL}	-0.3	—	0.8	V
Input Leakage Current (@V _I =3.3V or 0V)	I _L	—	—	± 4	μA
Input Capacitance	C _{IN}	—	—	16	pF
Digital Outputs					
Output High Voltage	V _{OH}	V _{DDE} - 0.2	—	V _{DDE}	V
Output Low Voltage	V _{OL}	0	—	0.2	V
High Level Output Current (@V _{OH} =2.8V)	I _{OH}	*1 (Note 2)			mA
Low Level Output Current (@V _{OL} =0.2V)	I _{OL}				mA
Tri-state Output Leakage Current (@V _O =2.5V or 0V)	I _{oz}	—	—	± 4	μA
Output Capacitance	C _O	—	—	16	pF
Analog Outputs					
DAC DC Output	V _{oc}	-0.1	—	1.2	V

PARAMETER	SYMBOL	MIN (NOTE 1)	TYP	MAX (NOTE 1)	UNITS
HDMI DC Output	---	0.4	0.5	0.6	V

ANALOG PERFORMANCE PARAMETER

PARAMETER	SYMBOL	MIN (NOTE 1)	TYP	MAX (NOTE 1)	UNITS
DAC Characteristic					
Differential Non-linearity	DNL	-1	—	+1	LSB
Output Impedance	Z _o	—	50	—	KΩs
DAC-to-DAC Matching		—	3	—	%
Signal-to-Noise and Distortion Ratio	SNDR	—	40	—	dB

NOTES:

1. Compliance to datasheet limits is assured by one or more methods: production test, characterization and/or design.
2. *1 Please refer to the CS101 I-V graph.

3.3V CMOS OUTPUT I/O, M-TYPE V-I CHARACTERISTICS

Conditions: MIN : Process = Slow, T_J = 125°C, V_{DDE} = 3.00V

TYP : Process = Typical, T_J = 25°C, V_{DDE} = 3.30V

MAX : Process = Fast, T_J = -40°C, V_{DDE} = 3.60V

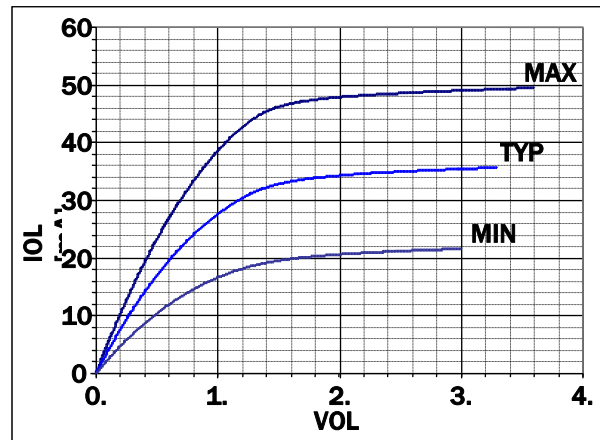
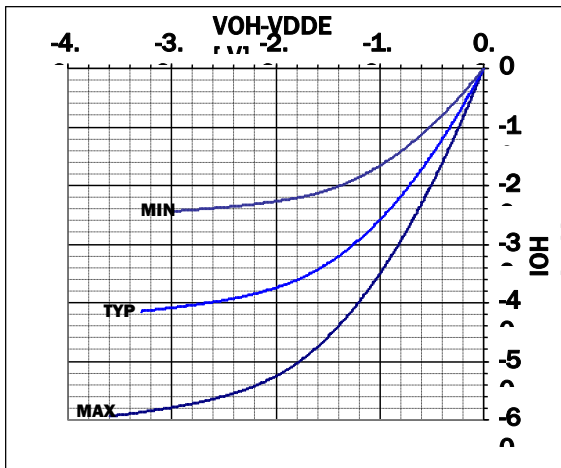

Chip Package

676-PIN Plastic BGA (27x27)

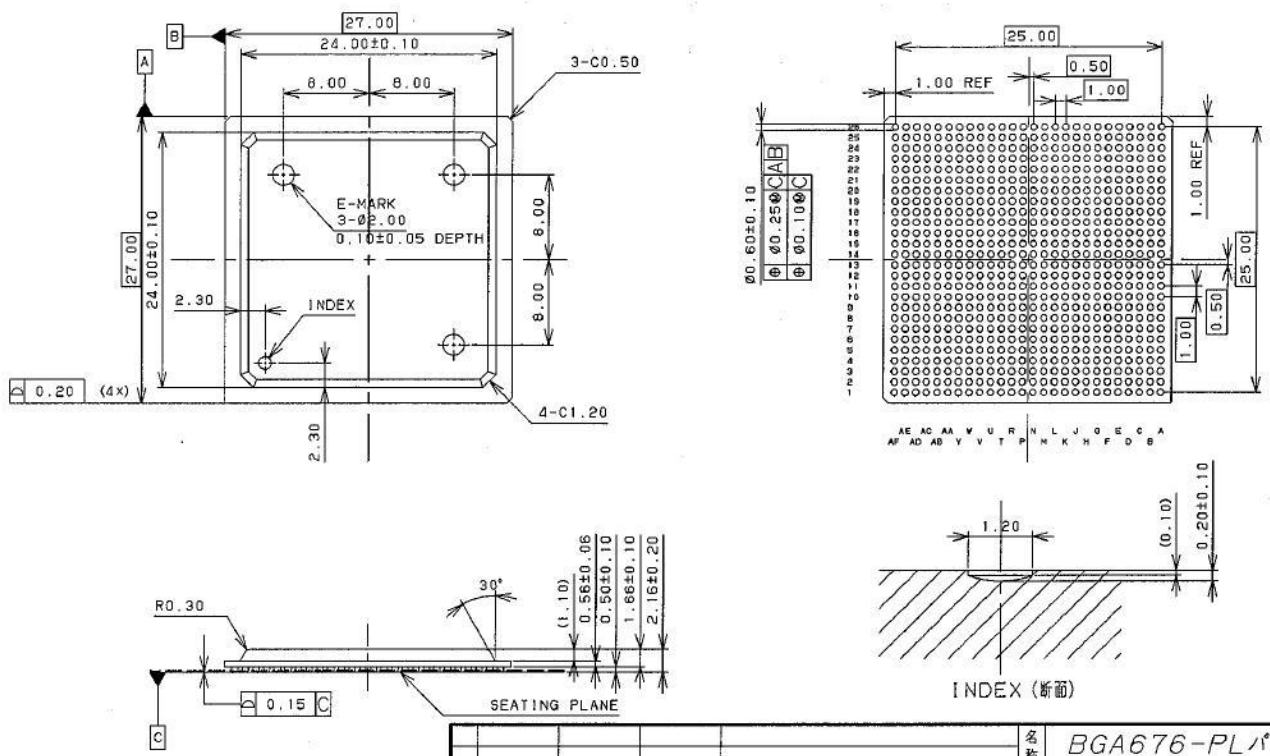

NOTE: All units in mm

Different Versions of TW2880

There are five possible versions of TW2880, each is tailored to a specific market. Please see the following table to understand the details. Currently, only two versions are available to order. One is called TW2880-P and the other is called TW2880-N. The difference between the two is TW2880-N's ball M4 is tied to ground, therefore, it only supports up to 12 channels of live inputs.

NAME	TYPE	BALL #84 (PAD0)	BALL #96 (PAD1)	OTHER OPTIONS
TW2880P	Premium	H	H	Full option
TW2880N	9 CH	H	H	Ball M4 (pad#70, P_ckvin_78) bond to low.
TW2880S	China, 3 SPOT	H	H	Ball AB13(pad#235, P_ana_SPOT4_CVBS) disconnect
TW2880M	Mid end	H	L	Display 64 bit, record 32 bit
TW2880B	Basic	L	L	Display 32 bit, record 32 bit

Video Interface and Down Scaler

Digital Video Input

The TW2880 has 8 digital video input ports which can receive video stream in normal ITU-R BT656 format running at 27 MHz, byte-interleaved BT.656 standard running at 54 or 108 MHz. In the latter configurations, TW2880 is expecting outputs from chips like TW2866 or TW2864 where high speed options are available. If TW2864 running at 108 MHz is used, only 4 input ports are needed. The unused ports can be used for other purposes. One thing needs to pay attention is the decoder has to use the clock provided by TW2880. This is for data synchronization purpose.

There is a small 16x16 FIFO in the beginning of the BT.656 decoder. The purpose is to accommodate possible drifting between input clock and the system clock.

In addition to the live inputs, there are four BT.656 ports running 27 (54 or 108) MHz or two BT.1120 HD ports available for playback monitoring. HD decoder will run at 74.25 MHz and in this mode, the display clock is set to twice the HD clock in 1080p mode.

After the digital data is decoded by the built-in BT 656 decoder, the image will be fed into a down scaler to adjust the final image to the desired sizes. The down scaler also generates corresponding vertical and horizontal timing signals and sends those to the write buffer.

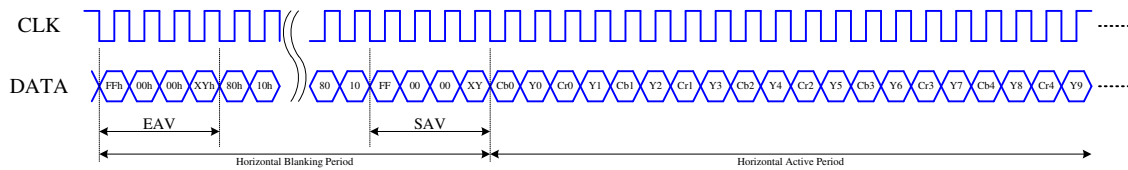

TIMING DIAGRAM OF BT.656 FORMAT FOR DIGITAL VIDEO INPUT

CONDITION			656 FVH VALUE			SAV/EAV CODE SEQUENCE												
FIELD	VERTICAL	HORIZONTAL	F	V	H	FIRST	SECOND	THIRD	FOURTH									
EVEN	Blank	EAV	1	1	1	0xFF	0x00	0x00	0xF1									
		SAV			0				0xEC									
EVEN	Active	EAV	1	0	1				0xFF	0x00	0x00	0xDA						
		SAV			0							0xC7						
ODD	Blank	EAV	0	1	1							0xFF	0x00	0x00	0xB6			
		SAV			0										0xAB			
ODD	Active	EAV	0	0	1										0xFF	0x00	0x00	0x9D
		SAV			0													0x80

BT.656 SAV AND EAV CODE SEQUENCE

The playback port will also decode two kinds of channel IDs sent by recorder. The content is stored in registers and for CPU to use.

Byte-interleaved Format

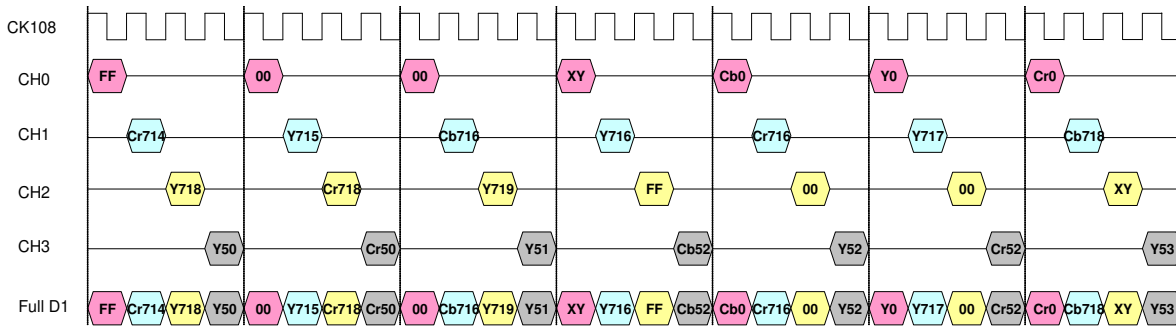

FOUR CHANNEL INPUT WITH 1 PORT FOR FULL D1

The above diagram depicts how a high speed byte-interleaved video sequence looks like. In this case we are transmitting 4 D1 channel running at 108 MHz. This input sequence will go to a de-multiplexing module and split into four normal BT.656 sequence for later consumption.

Down Scaler for Live Inputs

For each live channel, two sixteen-bit registers control the final video stream size. One is for horizontal ratio and the other one is for vertical ratio. Take window 1 for example, 0x301 and 0x300 is the horizontal down scale ratio register and 0x321 and 0x320 are the vertical down scale register. The formula is:

$$\text{Ratio} = 65535 * \text{target size} / \text{source size}.$$

From this formula we can see if the When down scaler is set to 65535 (0xFFFF), the down scaler is disabled.

There are four down scaler for play back ports. A detailed description is provided in a separate section.

AC Timing for Live and PB Input

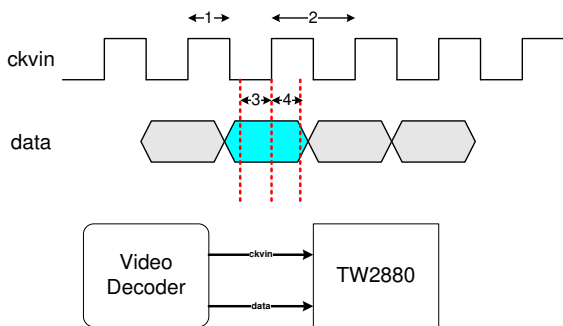

PARAMETER	SYMBOL	MIN	TYP	MAX	UNITS
Input Clock Half Period	1	4.39	4.62(108) 9.26(54), 18.52(27)	19.45	ns
Input Clock Period	2	8.78	9.25(108) 18.51(54), 37.03(27)	38.80	ns
Input Data Setup Time	3	3			ns
Input Data Hold Time	4	1.5			ns

Register Table

Page 3 is for live channel and play back channel

Address	R/W	Default	Description
0x300	R/W	0xFF	HSCL_X1[7:0]
0x301	R/W	0x7F	HSCL_X1[15:8]
0x302	R/W	0xFF	HSCL_X2[7:0]
0x303	R/W	0x7F	HSCL_X2[15:8]
0x304	R/W	0xFF	HSCL_X3[7:0]
0x305	R/W	0x7F	HSCL_X3[15:8]
0x306	R/W	0xFF	HSCL_X4[7:0]
0x307	R/W	0x7F	HSCL_X4[15:8]
0x308	R/W	0xFF	HSCL_X5[7:0]
0x309	R/W	0x7F	HSCL_X5[15:8]
0x30A	R/W	0xFF	HSCL_X6[7:0]
0x30B	R/W	0x7F	HSCL_X6[15:8]
0x30C	R/W	0xFF	HSCL_X7[7:0]
0x30D	R/W	0x7F	HSCL_X7[15:8]
0x30E	R/W	0xFF	HSCL_X8[7:0]
0x30F	R/W	0x7F	HSCL_X8[15:8]
0x310	R/W	0xFF	HSCL_X9[7:0]
0x311	R/W	0x7F	HSCL_X9[15:8]
0x312	R/W	0xFF	HSCL_X10[7:0]
0x313	R/W	0x7F	HSCL_X10[15:8]
0x314	R/W	0xFF	HSCL_X11[7:0]
0x315	R/W	0x7F	HSCL_X11[15:8]
0x316	R/W	0xFF	HSCL_X12[7:0]
0x317	R/W	0x7F	HSCL_X12[15:8]
0x318	R/W	0xFF	HSCL_X13[7:0]
0x319	R/W	0x7F	HSCL_X13[15:8]
0x31A	R/W	0xFF	HSCL_X14[7:0]
0x31B	R/W	0x7F	HSCL_X14[15:8]
0x31C	R/W	0xFF	HSCL_X15[7:0]
0x31D	R/W	0x7F	HSCL_X15[15:8]
0x31E	R/W	0xFF	HSCL_X16[7:0]
0x31F	R/W	0x7F	HSCL_X16[15:8]
0x320	R/W	0xFF	VSCL_X1[7:0]
0x321	R/W	0x7F	VSCL_X1[15:8]
0x322	R/W	0xFF	VSCL_X2[7:0]
0x323	R/W	0x7F	VSCL_X2[15:8]
0x324	R/W	0xFF	VSCL_X3[7:0]
0x325	R/W	0x7F	VSCL_X3[15:8]
0x326	R/W	0xFF	VSCL_X4[7:0]
0x327	R/W	0x7F	VSCL_X4[15:8]
0x328	R/W	0xFF	VSCL_X5[7:0]
0x329	R/W	0x7F	VSCL_X5[15:8]
0x32A	R/W	0xFF	VSCL_X6[7:0]
0x32B	R/W	0x7F	VSCL_X6[15:8]
0x32C	R/W	0xFF	VSCL_X7[7:0]
0x32D	R/W	0x7F	VSCL_X7[15:8]
0x32E	R/W	0xFF	VSCL_X8[7:0]
0x32F	R/W	0x7F	VSCL_X8[15:8]
0x330	R/W	0xFF	VSCL_X9[7:0]

Address	R/W	Default	Description
0x331	R/W	0x7F	VSCL_X9[15:8]
0x332	R/W	0xFF	VSCL_X10[7:0]
0x333	R/W	0x7F	VSCL_X10[15:8]
0x334	R/W	0xFF	VSCL_X11[7:0]
0x335	R/W	0x7F	VSCL_X11[15:8]
0x336	R/W	0xFF	VSCL_X12[7:0]
0x337	R/W	0x7F	VSCL_X12[15:8]
0x338	R/W	0xFF	VSCL_X13[7:0]
0x339	R/W	0x7F	VSCL_X13[15:8]
0x33A	R/W	0xFF	VSCL_X14[7:0]
0x33B	R/W	0x7F	VSCL_X14[15:8]
0x33C	R/W	0xFF	VSCL_X15[7:0]
0x33D	R/W	0x7F	VSCL_X15[15:8]
0x33E	R/W	0xFF	VSCL_X16[7:0]
0x33F	R/W	0x7F	VSCL_X16[15:8]
0x340	R/W	0x00	[7:6]: VSCL_MD_X4 [5:4]: VSCL_MD_X3 [3:2]: VSCL_MD_X2 [1:0]: VSCL_MD_X1
0x341	R/W	0x00	[7:6]: VSCL_MD_X8 [5:4]: VSCL_MD_X7 [3:2]: VSCL_MD_X6 [1:0]: VSCL_MD_X5
0x342	R/W	0x00	[7:6]: VSCL_MD_X12 [5:4]: VSCL_MD_X11 [3:2]: VSCL_MD_X10 [1:0]: VSCL_MD_X9
0x343	R/W	0x00	[7:6]: VSCL_MD_X16 [5:4]: VSCL_MD_X15 [3:2]: VSCL_MD_X14 [1:0]: VSCL_MD_X13
0x344	R/W	0x00	[7:6]: VSCL_MD_Y4 [5:4]: VSCL_MD_Y3 [3:2]: VSCL_MD_Y2 [1:0]: VSCL_MD_Y1
0x345	R/W	0x00	[7:6]: VSCL_MD_Y8 [5:4]: VSCL_MD_Y7 [3:2]: VSCL_MD_Y6 [1:0]: VSCL_MD_Y5
0x346	R/W	0x00	[7:6]: VSCL_MD_Y12 [5:4]: VSCL_MD_Y11 [3:2]: VSCL_MD_Y10 [1:0]: VSCL_MD_Y9
0x347	R/W	0x00	[7:6]: VSCL_MD_Y16 [5:4]: VSCL_MD_Y15 [3:2]: VSCL_MD_Y14 [1:0]: VSCL_MD_Y13
0x348	R/W	0x00	[7:6]: HLPF_MD_X4 [5:4]: HLPF_MD_X3 [3:2]: HLPF_MD_X2 [1:0]: HLPF_MD_X1

Address	R/W	Default	Description
0x349	R/W	0x00	[7:6]: HLPF_MD_X8 [5:4]: HLPF_MD_X7 [3:2]: HLPF_MD_X6 [1:0]: HLPF_MD_X5
0x34A	R/W	0x00	[7:6]: HLPF_MD_X12 [5:4]: HLPF_MD_X11 [3:2]: HLPF_MD_X10 [1:0]: HLPF_MD_X9
0x34B	R/W	0x00	[7:6]: HLPF_MD_X16 [5:4]: HLPF_MD_X15 [3:2]: HLPF_MD_X14 [1:0]: HLPF_MD_X13
0x34C	R/W	0x00	[7:6]: HLPF_MD_Y4 [5:4]: HLPF_MD_Y3 [3:2]: HLPF_MD_Y2 [1:0]: HLPF_MD_Y1
0x34D	R/W	0x00	[7:6]: HLPF_MD_Y8 [5:4]: HLPF_MD_Y7 [3:2]: HLPF_MD_Y6 [1:0]: HLPF_MD_Y5
0x34E	R/W	0x00	[7:6]: HLPF_MD_Y12 [5:4]: HLPF_MD_Y11 [3:2]: HLPF_MD_Y10 [1:0]: HLPF_MD_Y9
0x34F	R/W	0x00	[7:6]: HLPF_MD_Y16 [5:4]: HLPF_MD_Y15 [3:2]: HLPF_MD_Y14 [1:0]: HLPF_MD_Y13
0x350	R/W	0x00	[0]: PAL_DLY_X
0x351	R/W	0x00	[0]: PAL_DLY_Y
0x352	R/W	0x00	[3:0]: ODD_SKEW
0x353	R/W	0x00	[3:0]: EVEN_SKEW
0x354	R/W	0x00	[7]: MAN_VSCL_LPFY8 [6]: MAN_VSCL_LPFY7 [5]: MAN_VSCL_LPFY6 [4]: MAN_VSCL_LPFY5 [3]: MAN_VSCL_LPFY4 [2]: MAN_VSCL_LPFY3 [1]: MAN_VSCL_LPFY2 [0]: MAN_VSCL_LPFY1
0x355	R/W	0x00	[7]: MAN_VSCL_LPFY16 [6]: MAN_VSCL_LPFY15 [5]: MAN_VSCL_LPFY14 [4]: MAN_VSCL_LPFY13 [3]: MAN_VSCL_LPFY12 [2]: MAN_VSCL_LPFY11 [1]: MAN_VSCL_LPFY10 [0]: MAN_VSCL_LPFY9
0x356	R/W	0x00	[0]: TST_VSCL_VAV
0x35A	R/W	0xf0	VTAR_PB2[7:0]
0x35B	R/W	0xf0	VTAR_PB3[7:0]
0x35C	R/W	0x00	[6:4]: VTAR_PB4[10:8] [2:0]: VTAR_PB3[10:8]
0x35D	R/W	0xf0	VTAR_PB4[7:0]
0x35E	R/W	0xf0	VSOR_PB1[7:0]

Address	R/W	Default	Description
0x35F	R/W	0x00	[6:4]: VSOR_PB2[10:8] [2:0]: VSOR_PB1[10:8]
0x360	R/W	0xf0	VSOR_PB2[7:0]
0x361	R/W	0xf0	VSOR_PB3[7:0]
0x362	R/W	0x00	[6:4]: VSOR_PB4[10:8] [2:0]: VSOR_PB3[10:8]
0x363	R/W	0xf0	VSOR_PB4[7:0]
0x364	R/W	0xd0	HTAR_PB1[7:0]
0x365	R/W	0x22	[6:4]: HTAR_PB2[10:8] [2:0]: HTAR_PB1[10:8]
0x366	R/W	0xd0	HTAR_PB2[7:0]
0x367	R/W	0xd0	HTAR_PB3[7:0]
0x368	R/W	0x22	[6:4]: HTAR_PB4[10:8] [2:0]: HTAR_PB3[10:8]
0x369	R/W	0xd0	HTAR_PB4[7:0]
0x36A	R/W	0xd0	HSOR_PB1[7:0]
0x36B	R/W	0x22	[6:4]: HSOR_PB2[10:8] [2:0]: HSOR_PB1[10:8]
0x36C	R/W	0xd0	HSOR_PB2[7:0]
0x36D	R/W	0xd0	HSOR_PB3[7:0]
0x36E	R/W	0x22	[6:4]: HSOR_PB4[10:8] [2:0]: HSOR_PB3[10:8]
0x36F	R/W	0xd0	HSOR_PB4[7:0]
0x370	R/W	0x00	[7]: QUAD_AUTO_SCL_PB4 [6]: QUAD_AUTO_SCL_PB3 [5]: QUAD_AUTO_SCL_PB2 [4]: QUAD_AUTO_SCL_PB1 [3]: BYPASS_PB4 [2]: BYPASS_PB3 [1]: BYPASS_PB2 [0]: BYPASS_PB1
0x371	R/W	0x00	[7]: H_601_INV [6]: SYNC_SEL [5]: YC_SWITCH [4:2]: reserved [1]: IN16_MODE_PB34 [0]: IN16_MODE_PB12
0x372	RO	0	CHID_RD_BUS_PB1[39:32]
0x373	RO	0	CHID_RD_BUS_PB1[31:24]
0x374	RO	0	CHID_RD_BUS_PB1[23:16]
0x375	R/W	0x00	HDELAY_X1
0x376	R/W	0x00	HDELAY_X2
0x377	R/W	0x00	HDELAY_X3
0x378	R/W	0x00	HDELAY_X4
0x379	R/W	0x00	HDELAY_X5
0x37A	R/W	0x00	HDELAY_X6
0x37B	R/W	0x00	HDELAY_X7
0x37C	R/W	0x00	HDELAY_X8
0x37D	R/W	0x00	HDELAY_X9
0x37E	R/W	0x00	HDELAY_X10
0x37F	R/W	0x00	HDELAY_X11
0x380	R/W	0x00	HDELAY_X12
0x381	R/W	0x00	HDELAY_X13

Address	R/W	Default	Description
0x382	R/W	0x00	HDELAY_X14
0x383	R/W	0x00	HDELAY_X15
0x384	R/W	0x00	HDELAY_X16
0x385	R/W	0x00	[3:0]: HDELAY_Y1
0x386	R/W	0x00	[3:0]: HDELAY_Y2
0x387	R/W	0x00	[3:0]: HDELAY_Y3
0x388	R/W	0x00	[3:0]: HDELAY_Y4
0x389	R/W	0x00	[3:0]: HDELAY_Y5
0x38A	R/W	0x00	[3:0]: HDELAY_Y6
0x38B	R/W	0x00	[3:0]: HDELAY_Y7
0x38C	R/W	0x00	[3:0]: HDELAY_Y8
0x38D	R/W	0x00	[3:0]: HDELAY_Y9
0x38E	R/W	0x00	[3:0]: HDELAY_Y10
0x38F	R/W	0x00	[3:0]: HDELAY_Y11
0x390	R/W	0x00	[3:0]: HDELAY_Y12
0x391	R/W	0x00	[3:0]: HDELAY_Y13
0x392	R/W	0x00	[3:0]: HDELAY_Y14
0x393	R/W	0x00	[3:0]: HDELAY_Y15
0x394	R/W	0x00	[3:0]: HDELAY_Y16
0x395	R/W	0x00	VDELAY_X1
0x396	R/W	0x00	VDELAY_X2
0x397	R/W	0x00	VDELAY_X3
0x398	R/W	0x00	VDELAY_X4
0x399	R/W	0x00	VDELAY_X5
0x39A	R/W	0x00	VDELAY_X6
0x39B	R/W	0x00	VDELAY_X7
0x39C	R/W	0x00	VDELAY_X8
0x39D	R/W	0x00	VDELAY_X9
0x39E	R/W	0x00	VDELAY_X10
0x39F	R/W	0x00	VDELAY_X11
0x3A0	R/W	0x00	VDELAY_X12
0x3A1	R/W	0x00	VDELAY_X13
0x3A2	R/W	0x00	VDELAY_X14
0x3A3	R/W	0x00	VDELAY_X15
0x3A4	R/W	0x00	VDELAY_X16
0x3A5	R/W	0x00	[3:0]: VDELAY_Y1
0x3A6	R/W	0x00	[3:0]: VDELAY_Y2
0x3A7	R/W	0x00	[3:0]: VDELAY_Y3
0x3A8	R/W	0x00	[3:0]: VDELAY_Y4
0x3A9	R/W	0x00	[3:0]: VDELAY_Y5
0x3AA	R/W	0x00	[3:0]: VDELAY_Y6
0x3AB	R/W	0x00	[3:0]: VDELAY_Y7
0x3AC	R/W	0x00	[3:0]: VDELAY_Y8
0x3AD	R/W	0x00	[3:0]: VDELAY_Y9
0x3AE	R/W	0x00	[3:0]: VDELAY_Y10
0x3AF	R/W	0x00	[3:0]: VDELAY_Y11
0x3B0	R/W	0x00	[3:0]: VDELAY_Y12
0x3B1	R/W	0x00	[3:0]: VDELAY_Y13
0x3B2	R/W	0x00	[3:0]: VDELAY_Y14
0x3B3	R/W	0x00	[3:0]: VDELAY_Y15
0x3B4	R/W	0x00	[3:0]: VDELAY_Y16
0x3B5	R/W	0x00	[7:0]: HDELAY_PB1

Address	R/W	Default	Description
0x3B6	R/W	0x00	[7:0]: VDELAY_PB1
0x3B7	R/W	0x00	[7:0]: HDELAY_PB2
0x3B8	R/W	0x00	[7:0]: VDELAY_PB2
0x3B9	R/W	0x00	[7:0]: HDELAY_PB3
0x3BA	R/W	0x00	[7:0]: VDELAY_PB3
0x3BB	R/W	0x00	[7:0]: HDELAY_PB4
0x3BC	R/W	0x00	[7:0]: VDELAY_PB4
0x3BD	R/W	0	[7:6]: MAN_NOVID4 [5:4]: MAN_NOVID3 [3:2]: MAN_NOVID2 [1:0]: MAN_NOVID1
0x3BE	R/W	0	[7:6]:MAN_NOVID8 [5:4]: MAN_NOVID7 [3:2]: MAN_NOVID6 [1:0]: MAN_NOVID5
0x3BF	R/W	0	[7:6]:MAN_NOVID12 [5:4]: MAN_NOVID11 [3:2]: MAN_NOVID10 [1:0]: MAN_NOVID9
0x3C0	R/W	0	[7:6]:MAN_NOVID16 [5:4]: MAN_NOVID15 [3:2]: MAN_NOVID14 [1:0]: MAN_NOVID13
0x3C1	R/W	0	[7:6]:MAN_NON-STANDRED4 [5:4]: MAN_NON-STANDRED3 [3:2]: MAN_NON-STANDRED2 [1:0]: MAN_NON-STANDRED1
0x3C2	R/W	0	[7:6]:MAN_NON-STANDRED8 [5:4]: MAN_NON-STANDRED7 [3:2]: MAN_NON-STANDRED6 [1:0]: MAN_NON-STANDRED5
0x3C3	R/W	0	[7:6]:MAN_NON-STANDRED12 [5:4]: MAN_NON-STANDRED11 [3:2]: MAN_NON-STANDRED10 [1:0]: MAN_NON-STANDRED9
0x3C4	R/W	0	[7:6]:MAN_NON-STANDRED16 [5:4]: MAN_NON-STANDRED15 [3:2]: MAN_NON-STANDRED14 [1:0]: MAN_NON-STANDRED13
0x3C5	R/W	0	[6]: STILL_PAT [5]: PALNT [4]: IN_TEST [3]: Reserved [2]: CHID_BIT [1]: NO_CHID [0]: SYNC_CHID
0x3C6	R/W	0	[0]: SYS_60
0x3C7	RO	0	CHID_RD_BUS_PB1[15:8]
0x3C8	RO	0	CHID_RD_BUS_PB1[7:0]
0x3C9	RO	0	CHID_RD_BUS_PB2[39:32]
0x3CA	RO	0	CHID_RD_BUS_PB2[31:24]
0x3CC	RO	0	CHID_RD_BUS_PB2[23:16]
0x3CD	RO	0	CHID_RD_BUS_PB2[15:8]
0x3CE	RO	0	CHID_RD_BUS_PB2[7:0]

Address	R/W	Default	Description
0x3CF	R0	0	CHID_RD_BUS_PB3[39:32]
0x3D0	R0	0	CHID_RD_BUS_PB3[31:24]
0x3D1	R0	0	CHID_RD_BUS_PB3[23:16]
0x3D2	R/W	0x10	[7:4]: VIN_SEL_X2 / VIN_SEL_Y2 [3:0]: VIN_SEL_X1 / VIN_SEL_Y1
0x3D3	R/W	0x32	[7:4]: VIN_SEL_X4 / VIN_SEL_Y4 [3:0]: VIN_SEL_X3 / VIN_SEL_Y3
0x3D4	R/W	0x54	[7:4]: VIN_SEL_X6 / VIN_SEL_Y6 [3:0]: VIN_SEL_X5 / VIN_SEL_Y5
0x3D5	R/W	0x76	[7:4]: VIN_SEL_X8 / VIN_SEL_Y8 [3:0]: VIN_SEL_X7 / VIN_SEL_Y7
0x3D6	R/W	0x98	[7:4]: VIN_SEL_X10 / VIN_SEL_Y10 [3:0]: VIN_SEL_X9 / VIN_SEL_Y9
0x3D7	R/W	0xBA	[7:4]: VIN_SEL_X12 / VIN_SEL_Y12 [3:0]: VIN_SEL_X11 / VIN_SEL_Y11
0x3D8	R/W	0xDC	[7:4]: VIN_SEL_X14 / VIN_SEL_Y14 [3:0]: VIN_SEL_X13 / VIN_SEL_Y13
0x3D9	R/W	0xFE	[7:4]: VIN_SEL_X16 / VIN_SEL_Y16 [3:0]: VIN_SEL_X15 / VIN_SEL_Y15
0x3DA	R/W	0x01	[7]: VIN_SEL_XY [0]: V_OFST_X
0x3DB	R/W	0	[7:6]: PB_PATH_SEL4 [5:4]: PB_PATH_SEL3 [3:2]: PB_PATH_SEL2 [1:0]: PB_PATH_SEL1
0x3DC	R/W	0x12	PB_TEST_PATTEN [4]: DIR2 [3]: DIR1 [2:1]: FRAME_RATE [0]: IN_PB_TEST
0x3DD	RW	0x40	PIXEL_SHIFT
0x3DE	R/W	0x0F	[7:4]: CHID_RD_SEL_PB1 [3]: VBI_RIC_ON_PB1 [2]: VBI_AUTO_DET_PB1 [1]: VBI_D_EN_PB1 [0]: VBI_A_EN_PB1
0x3DF	R/W	0x00	[4:0]: VBI_VOS_PB1
0x3E0	R/W	0x80	[7:5]: VBI_PIXEL_WIDTH_PB1 [4:0]: VBI_FOS_PB1
0x3E1	R/W	0	VBI_HOS_PB1
0x3E2	R/W	0x1F	VBI_MID_VAL_PB1
0x3E3	R/W	0x0F	[7:4]: CHID_RD_SEL_PB2 [3]: VBI_RIC_ON_PB2 [2]: VBI_AUTO_DET_PB2 [1]: VBI_D_EN_PB2 [0]: VBI_A_EN_PB2
0x3E4	R/W	0x00	[4:0]: VBI_VOS_PB2
0x3E5	R/W	0x80	[7:5]: VBI_PIXEL_WIDTH_PB2 [4:0]: VBI_FOS_PB2
0x3E6	R/W	0x00	VBI_HOS_PB2
0x3E7	R/W	0x1F	VBI_MID_VAL_PB2

Address	R/W	Default	Description
0x3E8	R/W	0x0F	[7:4]CHID_RD_SEL_PB3 [3]: VBI_RIC_ON_PB3 [2]: VBI_AUTO_DET_PB3 [1]: VBI_D_EN_PB3 [0]: VBI_A_EN_PB3
0x3E9	R/W	0x00	[4:0]: VBI_VOS_PB3
0x3EA	R/W	0x80	[7:5]: VBI_PIXEL_WIDTH_PB3 [4:0]: VBI_FOS_PB3
0x3EB	R/W	0x00	VBI_HOS_PB3
0x3EC	R/W	0x1F	VBI_MID_VAL_PB3
0x3ED	R/W	0x0F	[7:4]: CHID_RD_SEL_PB4 [3]: VBI_RIC_ON_PB4 [2]: VBI_AUTO_DET_PB4 [1]: VBI_D_EN_PB4 [0]: VBI_A_EN_PB4
0x3EE	R/W	0x00	[4:0]: VBI_VOS_PB4
0x3EF	R/W	0x80	[7:5]: VBI_PIXEL_WIDTH_PB4 [4:0]: VBI_FOS_PB4
0x3F0	R/W	0x00	VBI_HOS_PB4
0x3F1	R/W	0x00	VBI_MID_VAL_PB2
0x3F2	R/W	0x00	[7]: FRAME_IL_PB4_EN [6]: FRAME_IL_PB3_EN [5]: FRAME_IL_PB2_EN [4]: FRAME_IL_PB1_EN [3]: FRAME_IL_PB4 [2]: FRAME_IL_PB3 [1]: FRAME_IL_PB2 [0]: FRAME_IL_PB1
0x3F3	R/W	0x00	[7]: FLD_MODE_PB4_EN [6]: FLD_MODE_PB3_EN [5]: FLD_MODE_PB2_EN [4]: FLD_MODE_PB1_EN [3]: FLD_MODE_PB4 [2]: FLD_MODE_PB3 [1]: FLD_MODE_PB2 [0]: FLD_MODE_PB1
0x3F4	R/W	0xFF	[7]: VBI_E_EN_PB4 [6]: VBI_E_EN_PB3 [5]: VBI_E_EN_PB2 [4]: VBI_E_EN_PB1 [3]: VBI_O_EN_PB4 [2]: VBI_O_EN_PB3 [1]: VBI_O_EN_PB2 [0]: VBI_O_EN_PB1
0x3FC	R/W	0	[7]: VBI_DLY4 [6]: VBI_DLY3 [5]: VBI_DLY2 [4]: VBI_DLY1 [3]: FLD_SEL_EN_PB4 [2]: FLD_SEL_EN_PB3 [1]: FLD_SEL_EN_PB2 [0]: FLD_SEL_EN_PB1
0x3FD	R/W	EE	[7:4]: VBI_SIZE_PB2 [3:0]: VBI_SIZE_PB1

Address	R/W	Default	Description
0x3FE	R/W	EE	[7:4]: VBI_SIZE_PB4 [3:0]: VBI_SIZE_PB3
0x3FF	R/W	0	[7]: selm [6]: PBX4_SEL [5]: PBX2_SEL [4]: MG_DIG_CODE [3]: VS_DIS_PB4 [2]: VS_DIS_PB3 [1]: VS_DIS_PB2 [0]: VS_DIS_PB1

Registers

Following are register descriptions for the live channel down scaler. Registers related to the PB down scaler will be described in a separate section.

LIVE VIDEO CHANNEL 1 HORIZONTAL SCALER LOW BYTE REGISTER – 0X300

Bit	R/W	Default	Description
7:0	R/W	0xFF	HSCL_X1[7:0] Horizontal scaler factor. Maximum is 0xFFFF. The number is smaller, the down scaler factor is bigger.

LIVE VIDEO CHANNEL 1 HORIZONTAL SCALER HIGH BYTE REGISTER – 0X301

Bit	R/W	Default	Description
7:0	R/W	0x7F	HSCL_X1[15:8] Horizontal scaler factor. Maximum is 0xFFFF. The number is smaller, the down scaler factor is bigger.

Register 0x302 to 0x31F are for channels 2 to 16, which are similar to 0x300 and 0x301.

LIVE VIDEO CHANNEL 1 VERTICAL SCALER LOW BYTE REGISTER – 0X320

Bit	R/W	Default	Description
7:0	R/W	0xFF	VSCL_X1[7:0] Vertical scaler factor. Maximum is 0xFFFF. The number is smaller, the down scaler factor is bigger.

LIVE VIDEO CHANNEL 1 VERTICAL SCALER HIGH BYTE REGISTER – 0X321

Bit	R/W	Default	Description
7:0	R/W	0xFF	VSCL_X1[15:8] Vertical scaler factor. Maximum is 0xFFFF. The number is smaller, the down scaler factor is bigger.

Register 0x322 to 0x33F are for channels 2 to 16, which are similar to 0x320 and 0x321.

LIVE VIDEO VERTICAL SCALE MODE REGISTER – 0X340

Bit	R/W	Default	Description
7:0	R/W	0x00	VSCL_MD_X [7:6]: VSCL_MD_X4 [5:4]: VSCL_MD_X3 [3:2]: VSCL_MD_X2 [1:0]: VSCL_MD_X1 Vertical scale mode

Register 0x341 to 0x343 are for other channels in display down scaler. Register 0x344 to 0x347 are for record down scaler.

LIVE VIDEO HORIZONTAL SCALE MODE REGISTER – 0X348

Bit	R/W	Default	Description
7:0	R/W	0x00	HLPF_MD_X [7:6]: HLPF_MD_X4 [5:4]: HLPF_MD_X3 [3:2]: HLPF_MD_X2 [1:0]: HLPF_MD_X1

Register 0x349 to 0x34B are for other channels in display down scaler. Register 0x34C to 0x34F are for record down scaler.

LIVE VIDEO PAL DELAY MODE REGISTER – 0X350

Bit	R/W	Default	Description
0	R/W	0x00	PAL_DLY_X

Register 0x351 is for record path.

LIVE VIDEO ODD FIELD SKEW REGISTER – 0X352

Bit	R/W	Default	Description
3:0	R/W	0x00	ODD_SKEW

Register 0x353 is for even field.

LIVE VIDEO VERTICAL SCALER LPF REGISTER – 0X354

Bit	R/W	Default	Description
7:0	R/W	0x00	MAN_VSCL_LPFY [7]: MAN_VSCL_LPFY8 [6]: MAN_VSCL_LPFY7 [5]: MAN_VSCL_LPFY6 [4]: MAN_VSCL_LPFY5 [3]: MAN_VSCL_LPFY4 [2]: MAN_VSCL_LPFY3 [1]: MAN_VSCL_LPFY2 [0]: MAN_VSCL_LPFY1

Register 0x355 is for channels 9 to 16

LIVE VIDEO VERTICAL SCALE VAV TEST REGISTER – 0X356

Bit	R/W	Default	Description
0	R/W	0x00	TST_VSCL_VAV

LIVE VIDEO CHANNEL 1 HORIZONTAL PIXEL ADJUSTMENT REGISTER – 0X375

Bit	R/W	Default	Description
7:0	R/W	0	HDELAY_X1[7:0] Number of pixels times two. This is for display video.

Register 0x376 to 0x384 are for channels 2 to 16.

LIVE VIDEO CHANNEL 1 HORIZONTAL PIXEL ADJUSTMENT REGISTER – 0X385

Bit	R/W	Default	Description
7:4	RW	0	Reserved
3:0	RW	0	HDELAY_Y1[3:0] Number of pixels times four. This is for record video.

Register 0x386 to 0x394 are for channels 2 to 16.

LIVE VIDEO CHANNEL 1 VERTICAL PIXEL ADJUSTMENT REGISTER – 0X395

Bit	R/W	Default	Description
7:0	R/W	0	VDELAY_X1[7:0] Number of lines times two. This is for display video.

LIVE VIDEO CHANNEL 1 VERTICAL PIXEL ADJUSTMENT REGISTER – 0X3A5

Bit	R/W	Default	Description
7:4	RW	0	Reserved
3:0	RW	0	VDELAY_Y1[3:0] Number of lines times four. This is for record video.

Register 0x3A6 to 0x3B4 are for channel 2 to 16.

LIVE VIDEO CHANNEL 1~4 NO VIDEO REGISTER – 0X3BD

Bit	R/W	Default	Description
7:6	RW	0	MAN_NOVID4: definition same as MAN_NOVID1
5:4	RW	0	MAN_NOVID3: definition same as MAN_NOVID1
3:2	RW	0	MAN_NOVID2: definition same as MAN_NOVID1
1:0	RW	0	MAN_NOVID1: no video status override enable If bit 1 is set to 0, no video status is automatically detected by hardware (default). If bit 1 is set to 1, no video status is manually set by bit 0. To fully utilize this feature, user needs to enable TW2864/TW2866 MPP_MODE[5] bit 1: 1= enable no video status override bit 0: 1: no video, 0: has video

Register 0x3BE to 0x3C0 are for channels 5 to 16.

LIVE VIDEO CHANNEL 1~4 NON STANDARD REGISTER – 0X3C1

Bit	R/W	Default	Description
7:6	RW	0	MAN_NON-STANDRED4: definition same as MAN_NON-STANDRED1
5:4	RW	0	MAN_NON-STANDRED3: definition same as MAN_NON-STANDRED1
3:2	RW	0	MAN_NON-STANDRED2: definition same as MAN_NON-STANDRED1
1:0	RW	0	MAN_NON-STANDRED1: non-standard video status override If bit 1 is set to 0, non-standard status is automatically detected by hardware (default). If bit 1 is set to one, non-standard status is manually set by bit 0. Bit 1: 1= enable non-standard video status override Bit 0: 1: non-standard video 0: standard video

Register 0x3C2 to 0x3C4 are for channels 5 to 16.

LIVE VIDEO CHANNEL CONTROL REGISTER – 0X3C5

Bit	R/W	Default	Description
7	R	0	Reserved
6	RW	0	STILL_PAT 0: moving pattern 1: still pattern
5	RW	0	PALNT: Only used for test pattern 0: NTSC pattern 1: PAL pattern
4	RW	0	IN_TEST 1 = Test pattern enable
3	RW	0	Reserved
2	RW	0	CHID_BIT 0: channel ID is 1 bit 1: channel ID is 2 bit
1	RW	0	NO_CHID 0: has channel ID in video data 1: no channel ID in video data
0	RW	0	SYNC_CHID: Channel ID location 0: in horizontal blank data last 2 bit 1: In timing reference data protection bit

LIVE VIDEO CHANNEL SYSTEM SELECT REGISTER – 0X3C6

Bit	R/W	Default	Description
7	RW	0	RECX4_SEL: This bit selects PB4 input in 16 bit mode 0: Input used is same as PBX4_SEL 1: Input comes from REC3 and REC4.
6	RW		RECX2_SEL: This bit selects PB2 input in 16 bit mode 0: Input used is same as PBX2_SEL 1: Input comes from REC1 and REC2.
5:1	R	0	Reserved
0	RW	0	SYS_60 0: 50Hz, PAL 1: 60Hz, NTSC

LIVE/RECORD CHANNEL SELECT REGISTER – 0X3D2

Bit	R/W	Default	Description
7:4	RW	1	VIN_SEL2 Input channel select for channel 2 for display or record. When VIN_SEL_XY is "0", this register is for display, when VIN_SEL_XY is "1", this register is for record.

Bit	R/W	Default	Description
3:0	RW	0	VIN_SEL1 Input channel select for channel 1.

Register 0x3D3 to 0x3D9 are for channels 3 to 16.

LIVE/RECORD SET SELECT REGISTER – 0X3DA

Bit	R/W	Default	Description
7	RW	0	VIN_SEL_XY This bit is used for select VIN_SEL X or Y. VIN_SEL share address for display and record. When VIN_SEL_XY is 0, VIN_SEL can be read/write for display. When VIN_SEL_XY is 1, VIN_SEL can be read/write for record.
6:1	R	0	Reserved
0	RW	1	V_OFST_X Vertical scale offset select

Play Back Interface

Introduction

The TW2880 supports 4 play back port. It can be 4x8-bit input or 4x16-bit input (with external FPGA). Playback port can be BT.656 format or BT.1120 format or a similar format. If channel ID is deployed, each playback port can support up to 16 channels (auto mode). The maximum horizontal resolution is 1920 for each port. The data rate can be up to 148.5MHz. The playback port can support both interlace or progressive video. Four high quality down scalars reside in each port.

Features

- Four channel HD input support ITU-R BT.1120 up to 148.5 MHz (with external FPGA)
- Four channel SD input support ITU-R BT.656 up to 108 MHz
- Channel ID detection in forms of analog and digital
- Cost efficient programmable down scalar with good quality
- Using same clock for input formatter and down scalar makes the system flexible for different applications

Description

PLAY BACK ARCHITECTURE

Play Back Architecture in BT.656 SD Mode

In BT.656 SD input mode, four channels are supported with the data rate at 27 MHz. Incoming 8-bit data format is Cb1 Y1 Cr1 Y2 Cb3 Y3 Cr3 Y4 ... Four input formatters `in_fmt_27` and four down scalars DNS are occupied. In each channel, both `in_fmt_27` and DNS use same clock `ckpb` and each channel has its own individual clock. `in_fmt_27` outputs Y, U and V data in 4:4:4 to down scalar DNS. DNS outputs Y, U and V data in 4:4:4 as well. Data will be converted to 4:2:2 chroma format in `dns_2_rgb_if`, which sends data to `rgb_interface`.

Down scalar DNS is acquired from the design TW2835 aimed to save circuit gate count while maintaining down scalar quality. Down scalar's output Y, Cb and Cr are converted to 16 bit data word to `dns_2_rgb_if` in the form of (Cb1 Y1) (Cr1Y2) (Cr3Y3) (Cb3Y4)... along with control signals of `hsync`, `vsync` and `field`. Decoded H blanking, V blanking and Field and data bus input to channel ID decoder `CHID_dec.v`. Channel ID decoder will decode Auto Channel ID, Detection Channel ID and User Channel ID. The results are readable by Host Interface.

BT.656 SD Input Mode

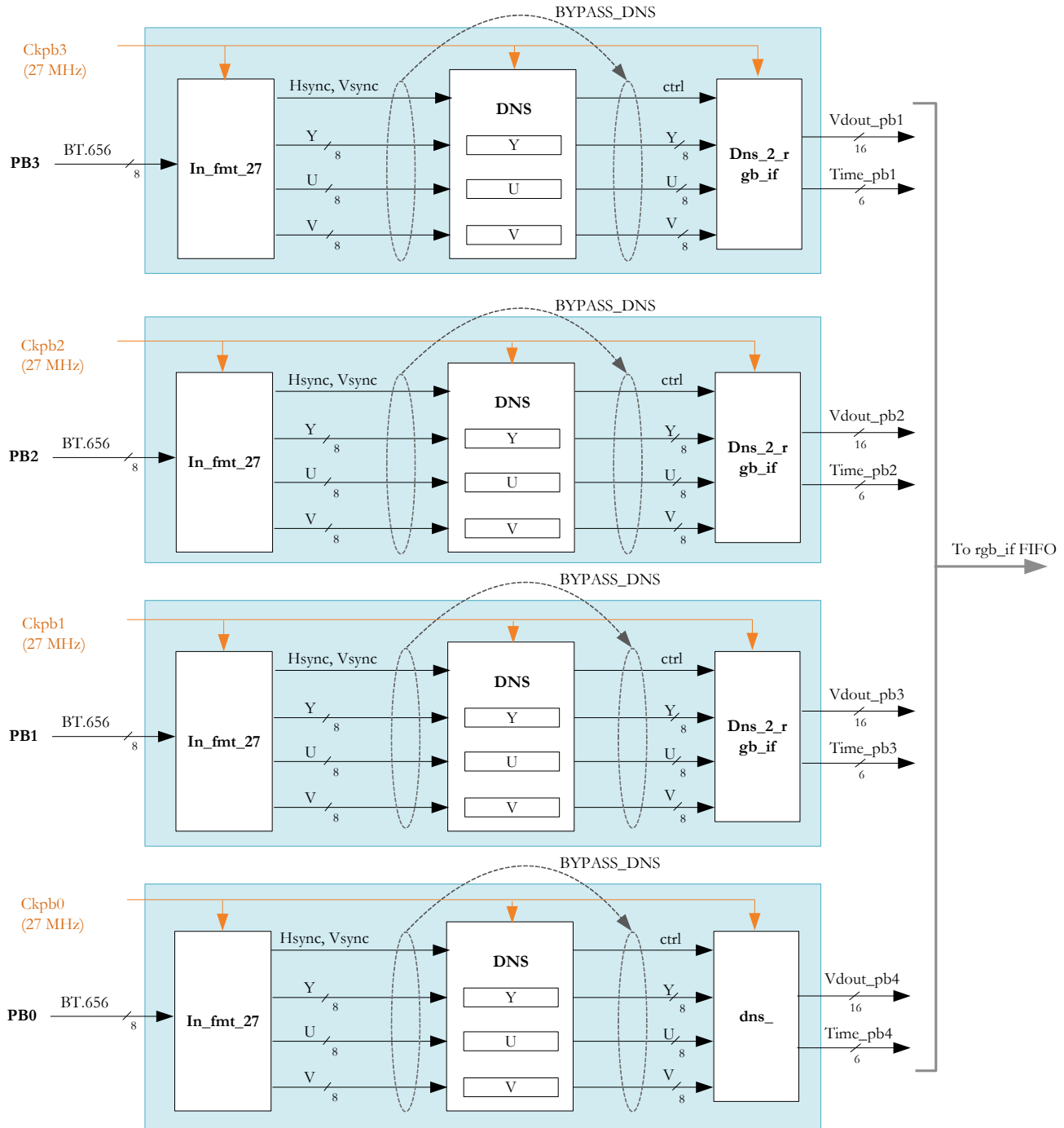

Play Back Architecture in 16-Bit Mode

In BT.1120 HD input mode, two channels are supported with data rate at 74.25 MHz. Each channel carries 16-bit data in the sequence of (Cb1, Y1) (Cr1, Y2) (Cb3, Y3) (Cr3, Y4). MSB 8 bits are Cb/Cr, LSB 8 bits are Y. One channel BT.1120 HD input data will use two input formatters **in_fmt_27**. Y bus goes to one **in_fmt_27**, Cb/Cr bus goes to another **in_fmt_27**. Two **in_fmt_27**'s outputs Y, U and V data as input data of one down scalar DNS. With two input

channels, only two DNSs will be used. In the following block diagram, the shaded block is denoted as not using module in BT.1120 mode. The interface format for dns_2_rgb_if is same as BT.656 mode.

BT.1120 HD Input Mode

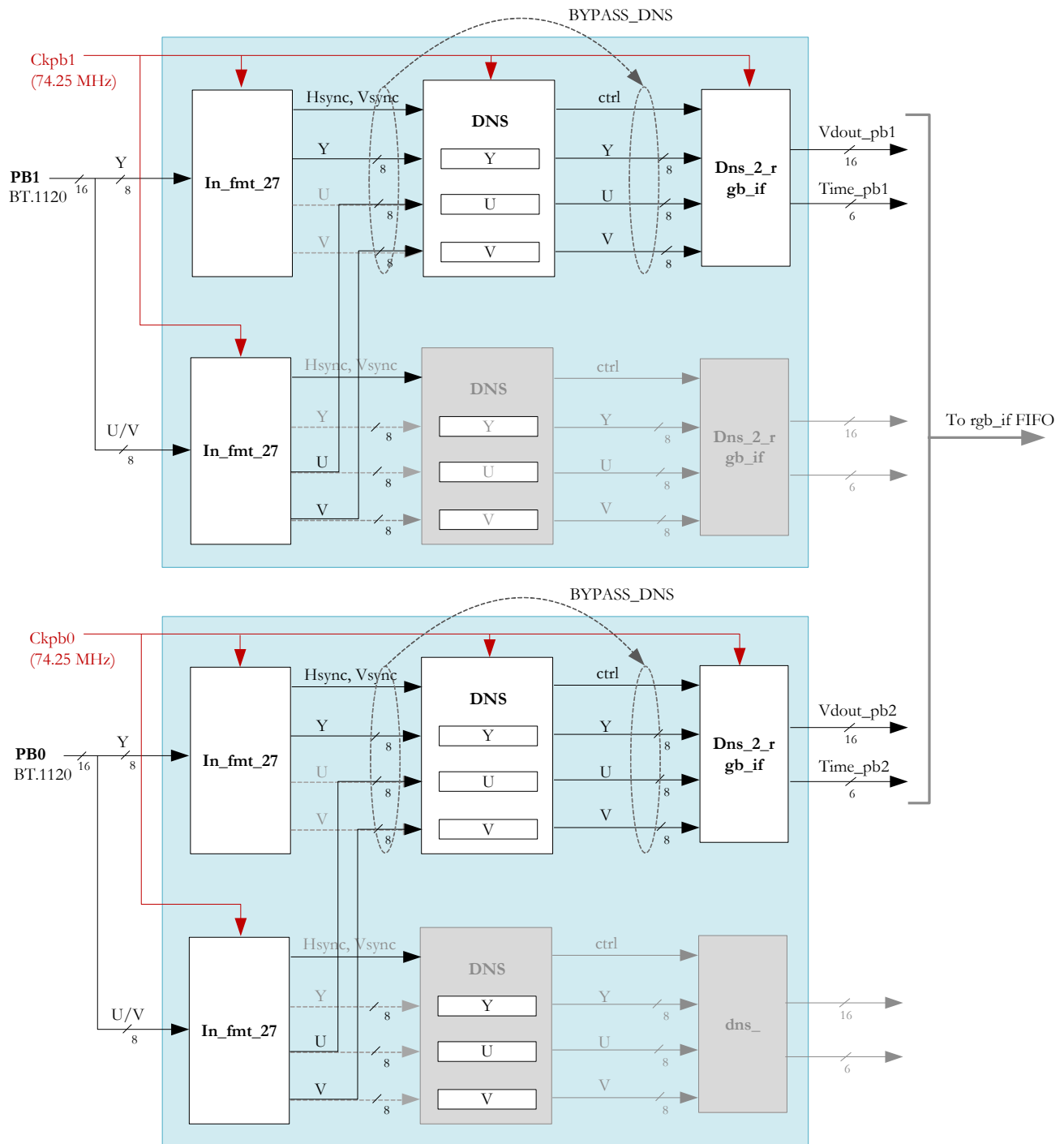

Interface with rgb_Interface

The outputs Y, Cb and Cr of down scalars either in BT.656 mode or BT.1120 mode convert to 16-bit data bus vdout_pb1 ~ vdout_pb4 in the sequence of (Cb, Y) (Cr, Y). Meanwhile, 6-bit control signal time_pb1 ~ tim_pb4 (carry hsync, vsync and field) will be provided in a format of {fld_d, new_in, end_in, new_fid, end_fid, valid}. This video data is write to rgb_interface channel buffer and further transferred to SDRAM for display.

The system has flexibility for play back clock rate since it uses same clock pbck1 ~ pbck4 for each channel from incoming video data through in_fmt_27, DNS data to channel buffer.

FUNCTIONS

INPUT FORMATTER

Input formatter in_fmt_27 supports SD BT.656 in NTSC, PAL or non-standard video format. In HD BT.1120, it supports 1920x1080i. It generates Y, Cb and Cr data bus to down scalar. HSYNC, VSYNC and VALID signals generate accordingly. In BT.1120 mode, in_fmt_27 can be set either take Y data or take Cb/Cr data and output Y or Cb/Cr will be generated respectively. Two in_fmt_27's outputs go to one down scalar.

HDELSY and VDELAY can be configured to get portion of one frame for display.

Down Scalar

There are four down scalar for four play back ports. Down scale ratio register is different from live channels. Source width and height must be set correctly. And target width and height will be set to desired size.

Channel ID Decoder

TW2880 Channel ID Decoder is using same protocol of TW2880 Channel ID encoder. For the detailed definition and description of Channel ID, please refer to Channel ID Encoder Unit.

There are twelve words (lines) of channel ID: one word of Auto Channel ID, two words of Detection Channel ID, three words of User Channel ID and 6 words (192 bits) Motion Detection Channel ID. They can be represented in terms of digital and analog formats. One of them or both can be existed in BT.656 video bit stream. Usually, they appear in horizontal active area of vertical blanking period. Channel ID encoder may also possible program them to vertical active area. But in this design, it only allows it in the first two top lines of active video area to ensure proper display video image. Any Channel ID information program outside of top two lines of active video area in both fields will be ignored in both Channel ID encoder and decoder. Analog Channel ID follows after digital channel ID if digital channel ID exists.

There are two modes to decoding channel ID: Auto detection and Non-auto detection. Digital channel ID can be detected fully automatic. However, decoding analog channel ID even in Auto mode requires extra host configuration.

Decoded twelve words of channel ID data and corresponding valid signals are readable by host.

Play Back Data Path Selection

Each channel has 2-bit selection control PB_PATH_SEL1 ~ PB_PATH_SEL4 to select one of four input data path. The selection can be made in the input of in_fmt_27. Please note each channel has its own clock and data should be corresponding to its own clock. This feature may useful in test and debugging.

Bypass Down Scalar

Each channel has its configuration bit BYPASS_PB to bypass down scalar. Input formatter's output directly goes to rgb_interface for display. If down scalar is set or in its default values HSCL = 16'h100 and VSCL = 16'h100, the system will perform bypass to maintain best display quality.

Display Part of Video Frame

Incoming video frame can be display partially by configuring HDELAY and VDELAY. Down scalar still can be applied.

Registers Table

Address	R/W	Default	Description
0x357	R/W	0x00	[7]: TOGGLE_FLD4 [6]: TOGGLE_FLD3 [5]: TOGGLE_FLD2 [4]: TOGGLE_FLD1 [3]: TST_FLDLY_Y [2]: TST_FLDLY_X [1]: TST_VSCL_Y [0]: TST_VSCL_X
0x358	R/W	0xf0	VTAR_PB1[7:0]
0x359	R/W	0x00	[6:4]: VTAR_PB2[10:8] [2:0]: VTAR_PB1[10:8]
0x35A	R/W	0xf0	VTAR_PB2[7:0]
0x35B	R/W	0xf0	VTAR_PB3[7:0]
0x35C	R/W	0x00	[6:4]: VTAR_PB4[10:8] [2:0]: VTAR_PB3[10:8]
0x35D	R/W	0xf0	VTAR_PB4[7:0]
0x35E	R/W	0xf0	VSOR_PB1[7:0]
0x35F	R/W	0x00	[6:4]: VSOR_PB2[10:8] [2:0]: VSOR_PB1[10:8]
0x360	R/W	0xf0	VSOR_PB2[7:0]
0x361	R/W	0xf0	VSOR_PB3[7:0]
0x362	R/W	0x00	[6:4]: VSOR_PB4[10:8] [2:0]: VSOR_PB3[10:8]
0x363	R/W	0xf0	VSOR_PB4[7:0]
0x364	R/W	0xd0	HTAR_PB1[7:0]
0x365	R/W	0x22	[6:4]: HTAR_PB2[10:8] [2:0]: HTAR_PB1[10:8]
0x366	R/W	0xd0	HTAR_PB2[7:0]
0x367	R/W	0xd0	HTAR_PB3[7:0]
0x368	R/W	0x22	[6:4]: HTAR_PB4[10:8] [2:0]: HTAR_PB3[10:8]
0x369	R/W	0xd0	HTAR_PB4[7:0]
0x36A	R/W	0xd0	HSOR_PB1[7:0]
0x36B	R/W	0x22	[6:4]: HSOR_PB2[10:8] [2:0]: HSOR_PB1[10:8]
0x36C	R/W	0xd0	HSOR_PB2[7:0]
0x36D	R/W	0xd0	HSOR_PB3[7:0]
0x36E	R/W	0x22	[6:4]: HSOR_PB4[10:8] [2:0]: HSOR_PB3[10:8]
0x36F	R/W	0xd0	HSOR_PB4[7:0]
0x370	R/W	0x00	[7]: QUAD_AUTO_SCL_PB4 [6]: QUAD_AUTO_SCL_PB3 [5]: QUAD_AUTO_SCL_PB2 [4]: QUAD_AUTO_SCL_PB1 [3]: BYPASS_PB4 [2]: BYPASS_PB3 [1]: BYPASS_PB2 [0]: BYPASS_PB1

Address	R/W	Default	Description
0x371	R/W	0x00	[7]: H_601_INV [6]: SYNC_SEL [5]: YC_SWITCH [4:2]: reserved [1]: IN16_MODE_PB34 [0]: IN16_MODE_PB12
0x372	RO	0	CHID_RD_BUS_PB1[39:32]
0x373	RO	0	CHID_RD_BUS_PB1[31:24]
0x374	RO	0	CHID_RD_BUS_PB1[23:16]
0x3B5	R/W	0x00	[7:0]: HDELAY_PB1
0x3B6	R/W	0x00	[7:0]: VDELAY_PB1
0x3B7	R/W	0x00	[7:0]: HDELAY_PB2
0x3B8	R/W	0x00	[7:0]: VDELAY_PB2
0x3B9	R/W	0x00	[7:0]: HDELAY_PB3
0x3BA	R/W	0x00	[7:0]: VDELAY_PB3
0x3BB	R/W	0x00	[7:0]: HDELAY_PB4
0x3BC	R/W	0x00	[7:0]: VDELAY_PB4
0x3C7	RO	0	CHID_RD_BUS_PB1[15:8]
0x3C8	RO	0	CHID_RD_BUS_PB1[7:0]
0x3C9	RO	0	CHID_RD_BUS_PB2[39:32]
0x3CA	RO	0	CHID_RD_BUS_PB2[31:24]
0x3CC	RO	0	CHID_RD_BUS_PB2[23:16]
0x3CD	RO	0	CHID_RD_BUS_PB2[15:8]
0x3CE	RO	0	CHID_RD_BUS_PB2[7:0]
0x3CF	RO	0	CHID_RD_BUS_PB3[39:32]
0x3D0	RO	0	CHID_RD_BUS_PB3[31:24]
0x3D1	RO	0	CHID_RD_BUS_PB3[23:16]
0x3DB	R/W	0	[7:6]: PB_PATH_SEL4 [5:4]: PB_PATH_SEL3 [3:2]: PB_PATH_SEL2 [1:0]: PB_PATH_SEL1
0x3DC	R/W	0x12	PB_TEST_PATTEN [4]: DIR2 [3]: DIR1 [2:1]: FRAME_RATE [0]: IN_PB_TEST
0x3DD	RW	0x40	PIXEL_SHIFT
0x3DE	R/W	0x0F	[7:4]: CHID_RD_SEL_PB1 [3]: VBI_RIC_ON_PB1 [2]: VBI_AUTO_DET_PB1 [1]: VBI_D_EN_PB1 [0]: VBI_A_EN_PB1
0x3DF	R/W	0x00	[4:0]: VBI_VOS_PB1
0x3E0	R/W	0x80	[7:5]: VBI_PIXEL_WIDTH_PB1 [4:0]: VBI_FOS_PB1
0x3E1	R/W	0	VBI_HOS_PB1
0x3E2	R/W	0x1F	VBI_MID_VAL_PB1
0x3E3	R/W	0x0F	[7:4]: CHID_RD_SEL_PB2 [3]: VBI_RIC_ON_PB2 [2]: VBI_AUTO_DET_PB2 [1]: VBI_D_EN_PB2 [0]: VBI_A_EN_PB2
0x3E4	R/W	0x00	[4:0]: VBI_VOS_PB2

Address	R/W	Default	Description
0x3E5	R/W	0x80	[7:5]: VBI_PIXEL_WIDTH_PB2 [4:0]: VBI_FOS_PB2
0x3E6	R/W	0x00	VBI_HOS_PB2
0x3E7	R/W	0x1F	VBI_MID_VAL_PB2
0x3E8	R/W	0x0F	[7:4]: CHID_RD_SEL_PB3 [3]: VBI_RIC_ON_PB3 [2]: VBI_AUTO_DET_PB3 [1]: VBI_D_EN_PB3 [0]: VBI_A_EN_PB3
0x3E9	R/W	0x00	[4:0]: VBI_VOS_PB3
0x3EA	R/W	0x80	[7:5]: VBI_PIXEL_WIDTH_PB3 [4:0]: VBI_FOS_PB3
0x3EB	R/W	0x00	VBI_HOS_PB3
0x3EC	R/W	0x1F	VBI_MID_VAL_PB3
0x3ED	R/W	0x0F	[7:4]: CHID_RD_SEL_PB4 [3]: VBI_RIC_ON_PB4 [2]: VBI_AUTO_DET_PB4 [1]: VBI_D_EN_PB4 [0]: VBI_A_EN_PB4
0x3EE	R/W	0x00	[4:0]: VBI_VOS_PB4
0x3EF	R/W	0x80	[7:5]: VBI_PIXEL_WIDTH_PB4 [4:0]: VBI_FOS_PB4
0x3F0	R/W	0x00	VBI_HOS_PB4
0x3F1	R/W	0x00	VBI_MID_VAL_PB2
0x3F2	R/W	0x00	[7]: FRAME_IL_PB4_EN [6]: FRAME_IL_PB3_EN [5]: FRAME_IL_PB2_EN [4]: FRAME_IL_PB1_EN [3]: FRAME_IL_PB4 [2]: FRAME_IL_PB3 [1]: FRAME_IL_PB2 [0]: FRAME_IL_PB1
0x3F3	R/W	0x00	[7]: FLD_MODE_PB4_EN [6]: FLD_MODE_PB3_EN [5]: FLD_MODE_PB2_EN [4]: FLD_MODE_PB1_EN [3]: FLD_MODE_PB4 [2]: FLD_MODE_PB3 [1]: FLD_MODE_PB2 [0]: FLD_MODE_PB1
0x3F4	R/W	0xFF	[7]: VBI_E_EN_PB4 [6]: VBI_E_EN_PB3 [5]: VBI_E_EN_PB2 [4]: VBI_E_EN_PB1 [3]: VBI_O_EN_PB4 [2]: VBI_O_EN_PB3 [1]: VBI_O_EN_PB2 [0]: VBI_O_EN_PB1
0x3F8	R/W	0x84	Non-standard Video Upper Limit - NTSC Register, 0x3ff[7] = 0 these registers will read out PB4 channel ID
0x3F9	R/W	0x6C	Non-standard Video Upper Limit - NTSC Register
0x3FA	R/W	0x9E	Non-standard Video Upper Limit - PAL Register
0x3FB	R/W	0x82	Non-standard Video Upper Limit - PAL Register

Address	R/W	Default	Description
0x3FC	R/W	0	[7]: VBI_DLY4 [6]: VBI_DLY3 [5]: VBI_DLY2 [4]: VBI_DLY1 [3]: FLD_SEL_EN_PB4 [2]: FLD_SEL_EN_PB3 [1]: FLD_SEL_EN_PB2 [0]: FLD_SEL_EN_PB1
0x3FD	R/W	EE	[7:4]: VBI_SIZE_PB2 [3:0]: VBI_SIZE_PB1
0x3FE	R/W	EE	[7:4]: VBI_SIZE_PB4 [3:0]: VBI_SIZE_PB3
0x3FF	R/W	0	[7]: selm [6]: PBX4_SEL [5]: PBX2_SEL [4]: MG_DIG_CODE [3]: VS_DIS_PB4 [2]: VS_DIS_PB3 [1]: VS_DIS_PB2 [0]: VS_DIS_PB1

Registers Description

TOGGLE FIELD SIGNAL ENABLE REGISTER – 0X357

Bit	R/W	Default	Description
7:4	RW	0	TOGGLE_FLD4 - TOGGLE_FLD1 These bits are used for progressive play back capture mode. In progressive mode, field signal is always 0. If this bit is set to high, hardware will generate toggled field signal for channel ID decoder. It is toggled after 3 line of the beginning of vertical blank. 1: toggle field signal for channel ID decoder 0: use original field signal
3	RW	0	TST_FLDLY_Y
2	RW	0	TST_FLDLY_X
1	RW	0	TST_VSCL_Y
0	RW	0	TST_VSCL_X

PB1 VERTICAL TARGET SIZE LSB REGISTER – 0X358

Bit	R/W	Default	Description
7:0	RW	0xf0	VTAR_PB1[7:0] PB1 down scalar vertical target size. Unit is one line. In interlaced mode, this register should set to half of the vertical lines of one frame.

PB1 AND PB2 VERTICAL TARGET SIZE MSB REGISTER – 0X359

Bit	R/W	Default	Description
6:4	RW	0x0	VTAR_PB2[10:8] PB2 down scalar vertical target size. Unit is one line. In interlaced mode, this register is set to half of the vertical lines of one frame.
2:0	RW	0x0	VTAR_PB1[10:8] PB1 down scalar vertical target size. Unit is one line. In interlaced mode, this register is set to half of the vertical lines of one frame.

PB2 VERTICAL TARGET SIZE LSB REGISTER – 0X35A

Bit	R/W	Default	Description
7:0	RW	0xf0	VTAR_PB2[7:0] PB2 down scalar vertical target size. Unit is one line. In interlaced mode, this register is set to half of the vertical lines of one frame.

Registers 0x35B to 0x35D are for PB channels 3 and 4.

PB1 VERTICAL SOURCE SIZE LSB REGISTER – 0X35E

Bit	R/W	Default	Description
7:0	RW	0xf0	VSOR_PB1[7:0] PB1 down scalar vertical source size. Unit is one line. In interlaced mode, this register is set to half of the vertical lines of one frame.

PB1 AND PB2 VERTICAL SOURCE SIZE MSB REGISTER – 0X35F

Bit	R/W	Default	Description
6:4	RW	0x00	VSOR_PB2[10:8] PB2 down scalar vertical source size. Unit is one line. In interlaced mode, this register is set to half of the vertical lines of one frame.
2:0	RW	0x0	VSOR_PB1[10:8] PB1 down scalar vertical source size. Unit is one line. In interlaced mode, this register is set to half of the vertical lines of one frame.

PB2 VERTICAL SOURCE SIZE LSB REGISTER – 0X360

Bit	R/W	Default	Description
7:0	RW	0xf0	VSOR_PB2[7:0] PB2 down scalar vertical source size. Unit is one line. In interlaced mode, this register is set to half of the vertical lines of one frame.

Registers 0x361 to 0x363 are for PB channels 3 and 4.

PB1 HORIZONTAL SCALER TARGET LSB REGISTER – 0X364

Bit	R/W	Default	Description
7:0	RW	0xd0	HTAR_PB1[7:0] PB1 down scalar horizontal target size. Unit is one pixel.

PB1 AND PB2 HORIZONTAL TARGET SIZE MSB REGISTER – 0X365

Bit	R/W	Default	Description
6:4	RW	0x2	HTAR_PB2[10:8] PB2 down scalar horizontal target size. Unit is one pixel.
2:0	RW	0x2	HTAR_PB1[10:8] PB1 down scalar horizontal target size. Unit is one pixel.

PB2 HORIZONTAL SCALER TARGET LSB REGISTER – 0X366

Bit	R/W	Default	Description
7:0	RW	0xd0	HTAR_PB2[7:0] PB2 down scalar horizontal target size. Unit is one pixel.

Registers 0x367 to 0x369 are for channels 3 and 4.

PB1 HORIZONTAL SCALER SOURCE LSB REGISTER – 0X36A

Bit	R/W	Default	Description
7:0	RW	0xd0	HSOR_PB1[7:0] PB1 down scalar horizontal source size. Unit is one pixel.

PB1 AND PB2 HORIZONTAL SOURCE SIZE MSB REGISTER – 0X36B

Bit	R/W	Default	Description
6:4	RW	0x2	HSOR_PB2[10:8] PB2 down scalar horizontal source size. Unit is one pixel.
2:0	RW	0x2	HSOR_PB1[10:8] PB1 down scalar horizontal source size. Unit is one pixel.

PB2 HORIZONTAL SCALER SOURCE LSB REGISTER – 0X36C

Bit	R/W	Default	Description
7:0	RW	0xd0	HSOR_PB2[7:0] PB2 down scalar horizontal source size. Unit is one pixel.

Registers 0x36D to 0x36F are for channels 3 and 4.

PB AUTO DOWNSCALE AND BYPASS REGISTER – 0X370

Bit	R/W	Default	Description
7:4	RW	0	QUAD_AUTO_SCL_PB4 - QUAD_AUTO_SCL_PB1 Down scale ratio can be changed in multi-mode for each play back port 1: enable, D1 and Quad is 2:1 in down scale ratio 0: disable, down scale ratio keep same
3:0	RW	0x1	BYPASS_PB4 - BYPASS_PB1 Bypass down scalar. Video data from in_fmt_27 directly go to rgb_interface for display. 1: enable 0: disable

PB MISC CONTROL REGISTER – 0X371

Bit	R/W	Default	Description
7	RW	0x0	Reserved
6	RW	0x0	SYNC_SEL: When this bit is set to high, use external H/V/F sync. 1: use external sync 0: use embedded sync
5	RW	0x1	YC_SWITCH: YC switch in 16bit mode 1: Y in port 2, C in port 1 0: Y in port 1, C in port 2
4	RW	0	SYNC656_SEL 1 = Play back port sync from state machine 0 = Play back port sync from byte compare
3	RW	0	IN_16BIT_RGB_MODE34 1 = 16 bit Play back port input format = 565RGB 0 = default
2	RW	0	IN_16BIT_RGB_MODE12 1 = 16 bit Play back port input format = 565RGB 0 = default
1	RW	0	IN16_MODE_PB34: Play back port 3 and 4 data is 16bit or 8bit 1: 16bit 0: 8bit
0	RW	0	IN16_MODE_PB12: Play back port 1 and 2 data is 16bit or 8bit 1: 16bit 0: 8bit

HORIZONTAL DELAY FOR PLAYBACK PORT 1 REGISTER – 0X3B5

Bit	R/W	Default	Description
7:0	RW	0x0	HDELAY_PB1 Horizontal Delay (Cut off left side) of horizontal active picture in unit of two pixels.

VERTICAL DELAY FOR PLAYBACK PORT 1 REGISTER – 0X3B6

Bit	R/W	Default	Description
7:0	RW	0x0	VDELAY_PB1 Horizontal Delay (Cut off top portion) of vertical active picture in unit of one line.

Registers 0x3B7 to 0x3BC are for PB ports 2 to 4

PB PATH SELECTION REGISTER – 0X3DB

Bit	R/W	Default	Description
7:6	RW	3	PB_PATH_PB4 : PB4 down scalar input select. If PBX4_SEL is low, the input is the same as PB3. If PBX4_SEL is one, input is coming from live input7, 8 or record 3, 4
5:4	RW	2	PB_PATH_PB3 : PB3 down scalar input select. Remember in 16 bit mode user needs to select input 4 as one set.
3:2	RW	1	PB_PATH_PB2 : PB2 down scalar input select. If PBX2_SEL is low, the input is the same as PB1. If PBX2_SEL is one, input is coming from live input5, 6 or record 1, 2
1:0	RW	0	PB_PATH_PB1 : PB1 down scalar input select. Remember in 16 bit mode user needs to select input 2 as one set. 3: select PB4 input pins 2: select PB3 input pins 1: select PB2 input pins 0: select PB1 input pins

PB IN_PB_TEST REGISTER – 0X3DC

Bit	R/W	Default	Description
7:5	RW	0x0	Reserved
4	RW	0x0	DIR2 : PB test pattern generator BT1120_gen2 color bar shift direction. 1: shift to left 0: shift to right
3	RW	0x1	DIR1 : PB test pattern generator BT1120_gen1 color bar shift direction. 1: shift to left 0: shift to right

Bit	R/W	Default	Description
2:1	RW	0x0	Frame Rate PB test pattern generator color bar shift frame rate for both BT1120_gen1 and BT1120_gen2 0: change every 16 frame 1: change every 32 frame Others: change every 64 frame
0	RW	0x0	IN_PB_TEST: PB test pattern generator color bar for PB in BT.1120 1: enable PB HD color bar generator 0: disable. PB use data from port.

PB IN_PB_TEST PATTERN GENERATOR COLOR BAR SHIFT VOLUM – 0X3DD

Bit	R/W	Default	Description
7:0	RW	0x0	PIXEL_SHIFT HD Color bar shift volume in unit of pixel

PB CHANNEL ID DEC PB1 CTRL – 0X3DE

Bit	R/W	Default	Description
7:4	RW	0x0	CHID_RD_SEL_PB1 Host selects one of 11 CHID words to read. b: User CHID3 a: User CHID2 9: User CHID1 8: Motion detection CHID6 7: Motion detection CHID5 6: Motion detection CHID4 5: Motion detection CHID3 4: Motion detection CHID2 3: Motion detection CHID1 2: Detection CHID2 1: Detection CHID1 0: Auto CHID
3	RW	0x1	VBI_RIC_ON_PB1 Enable run in clock detection. It should be same as CHID encoder configured. 1: enable 0: disable
2	RW	0x1	VBI_AUTO_DET_PB1 Automatic detect channel ID for digital channel ID vertical offset and analog channel ID run in clock frequency. 1: enable 0: disable
1	RW	0x1	VBI_D_EN_PB1: Enable digital CHID. It should be same as CHID encoder 1: enable 0: disable

Bit	R/W	Default	Description
0	RW	0x1	VBI_A_EN_PB1: Enable analog CHID. It should be same as CHID encoder, if both enable then use analog CHID. 1: enable 0: disable

PB CHANNEL ID DEC PB1 VOS – 0X3DF

Bit	R/W	Default	Description
4:0	RW	0x0	VBI_VOS_PB1 Line number of vertical offset for channel id in First field in unit of one.

PB CHANNEL ID DEC PB1 FOS – 0X3E0

Bit	R/W	Default	Description
7:5	RW	0x4	VBI_PIXEL_WIDTH_PB1 Define half width of analog CHID sample rate.
4:0	RW	0x1	VBI_FOS_PB1 Line number of vertical offset for channel id in second field in unit of one

PB CHANNEL ID DEC PB1 HOS – 0X3E1

Bit	R/W	Default	Description
7:0	RW	0x1	VBI_HOS_PB1: Pixel horizontal offset for channel.

PB CHANNEL ID DEC PB1 MID_VAL – 0X3E2

Bit	R/W	Default	Description
7:0	RW	0x1	VBI_MID_VAL_PB1 Middle value of VIS_HIGH_VAL and VIS_LOW_VAL in CHID encoder.

PB FRAME/FIELD CONTROL REGISTER – 0X3F2

Bit	R/W	Default	Description
7:4	RW	0	FRAME_IL_PB4_EN – FRAME_IL_PB1_EN: Force the receiving mode of PB4 – PB1 to follow the value of bit [3:0]. 1: enable 0: disable
3:0	RW	0	FRAME_IL_PB4 - FRAME_IL_PB1: Host define the stream is frame interleaved or field interleaved. 1: field interleaved mode (auto), interlaced mode (normal) 0: frame interleaved mode (auto), progressive mode (normal)

PB FIELD MODE REGISTER – 0X3F3

Bit	R/W	Default	Description
7:4	RW	0	FLD_MODE_PB4_EN - FLD_MODE_PB1_EN: Manual set field mode 1: enable, get field mode from FLD_MODE_PB4-1 0: disable, get field mode from channel ID
3:0	RW	0	FLD_MODE_PB4 - FLD_MODE_PB1: Field mode in manual mode for port 4-1 1: even field when fld is 0 0: even field when fld is 1

PB DIGITAL CHANNEL ID ENABLE REGISTER – 0X3F4

Bit	R/W	Default	Description
7:4	RW	1	VBI_E_EN_PB4 - VBI_E_EN_PB1: Digital CHID even field enable 1: enable 0: disable
3:0	RW	1	VBI_O_EN_PB4 - VBI_O_EN_PB1: Digital CHID odd field enable 1: enable 0: disable

NON-STANDARD VIDEO UPPER LIMIT - NTSC REGISTER – 0X3F8

Bit	R/W	Default	Description
7:0	R/W	0x84	NT_UP_LIM: NTSC line counter upper limit, unit is double line

NON-STANDARD VIDEO LOWER LIMIT - NTSC REGISTER – 0X3F9

Bit	R/W	Default	Description
7:0	R/W	0x6c	NT_DOWN_LIM: NTSC line counter lower limit, unit is double line

NON-STANDARD VIDEO UPPER LIMIT - PAL REGISTER – 0X3FA

Bit	R/W	Default	Description
7:0	R/W	0x9e	NT_UP_LIM: PAL line counter upper limit, unit is double line

NON-STANDARD VIDEO LOWER LIMIT - PAL REGISTER – 0X3FB

Bit	R/W	Default	Description
7:0	R/W	0x82	NT_DOWN_LIM: PAL line counter lower limit, unit is double line

When 3FF [7] = 1, the read data of 0x3F8 - 0x3FB is CHID of PB4.

PB CHID DECODER CONTROL REGISTER – 0X3FC

Bit	R/W	Default	Description
7:4	RW	0	VBI_DLY4 - VBI_DLY1: 1 = New field signal delay one line. It is used for digital channel ID in first active line.
3:0	RW	0	FLD_SEL_EN_PB4 - FLD_SEL_EN_PB1: Field signal source selection 1: from embedded field signature. 0: from channel ID

When 3C6 [1] = 1, the read data of 0x3FC and 0x3FD is non-standard video signal of live channels.

ANALOG CHANNEL ID LINE NUMBER REGISTER 1 – 0X3FD

Bit	R/W	Default	Description
7:4	RW	0xE	VBI_SIZE_PB2 Analog channel ID line number for PB port 2
3:0	RW	0xE	VBI_SIZE_PB1 Analog channel ID line number for PB port 1

ANALOG CHANNEL ID LINE NUMBER REGISTER 2 – 0X3FE

Bit	R/W	Default	Description
7:4	RW	0xE	VBI_SIZE_PB4: Analog channel ID line number for PB port 4
3:0	RW	0xE	VBI_SIZE_PB3: Analog channel ID line number for PB port 3

MISC. CONTROL REGISTER – 0X3FF

Bit	R/W	Default	Description
7	RW	0	selm: This bit selects the output of 0x3f8 – 0x3fb 1: Output of PB port channel ID 0: Output of 0x3f8 – 0x3fb.
6	RW	0	PBX4_SEL: This bit selects the PB4 input in 16 bit mode 1: Input coming from Live7 and Live8 or REC3 and REC4 determined by RECX4_SEL 0: Input used is same as PB3
5	RW	0	PBX2_SEL: This bit selects the PB2 input in 16 bit mode 1: Input use Live5 and Live6 or REC1 and REC2 determined by RECX2_SEL 0: Input used is same as PB1
4	RW	0	DIG_CODE: This bit selects digital channel ID start code 1: 0x80_9F_80_90 0: 0x00_9F_00_90

Bit	R/W	Default	Description
3:0	RW	0	VS_DIS4 – VS_DIS1: New field signal disabled in even field for progressive mode 1: disable even field new field signal 0: don't disable even field new field signal

PB CHANNEL ID DEC READ BUS PB1 BYTE 1– 0X372

Bit	R/W	Default	Description
7:0	R	0x7	CHID_RD_BUS_PB1[39:32] Read CHID_rd_bus_pb1[39:32]. Depend on CHID_RD_SEL_PB1(REG OX3DE), it read one of six CHID word: 0: auto CHID [7] digital_chid_valid_pb1, 1: D CHID valid, 0: A CHID valid [6] auto_valid_pb1, 1: auto_CHID valid, 0 not valid [5:0] auto_chid_pb1[37:32] 1: detection CHID1 [7] digital_chid_valid_pb1, 1: D CHID valid, 0: A CHID valid [4] det1_valid_pb1, 1: det1_CHID valid, 0 not valid [3:0] det1_chid_pb1[35:32] 2: detection CHID2 [7] digital_chid_valid_pb1, 1: D CHID valid, 0: A CHID valid [4] det2_valid_pb1, 1: det2_CHID valid, 0 not valid [3:0] det2_chid_pb1[35:32] 3: Motion detection CHID1 [7] digital_chid_valid_pb1, 1: D CHID valid, 0: A CHID valid [4] det3_valid_pb1, 1: det2_CHID valid, 0 not valid [3:0] de3_chid_pb1[35:32] 4: Motion detection CHID1 [7] digital_chid_valid_pb1, 1: D CHID valid, 0: A CHID valid [4] det4_valid_pb1, 1: det4_CHID valid, 0 not valid [3:0] det4_chid_pb1[35:32] 5: Motion detection CHID1 [7] digital_chid_valid_pb1, 1: D. CHID valid, 0: A. CHID valid [4] det5_valid_pb1, 1: det5_CHID valid, 0 not valid [3:0] det5_chid_pb1[35:32] 6: Motion detection CHID1 [7] digital_chid_valid_pb1, 1: D CHID valid, 0: A CHID valid [4] det6_valid_pb1, 1: det6_CHID valid, 0 not valid [3:0] det6_chid_pb1[35:32] 7: Motion detection CHID1 [7] digital_chid_valid_pb1, 1: D CHID valid, 0: A CHID valid [4] det7_valid_pb1, 1: det7_CHID valid, 0 not valid [3:0] det7_chid_pb1[35:32] 8: Motion detection CHID1 [7] digital_chid_valid_pb1, 1: D CHID valid, 0: A CHID valid

Bit	R/W	Default	Description
			<p>[4] det8_valid_pb1, 1: det8_CHID valid, 0 not valid [3:0] det8_chid_pb1[35:32]</p> <p>9: user CHID1 [7] digital_chid_valid_pb1, 1: D CHID valid, 0: A CHID valid [4] usr1_valid_pb1, 1: usr1_CHID valid, 0 not valid [3:0] usr1_chid_pb1[35:32]</p> <p>a: user CHID2 [7] digital_chid_valid_pb1, 1: D CHID valid, 0: A CHID valid [4] usr2_valid_pb1, 1: usr2_CHID valid, 0 not valid [3:0] usr2_chid_pb1[35:32]</p> <p>b: user CHID3 [7] digital_chid_valid_pb1, 1: D CHID valid, 0: A CHID valid [4] usr3_valid_pb1, 1: usr3_CHID valid, 0 not valid [3:0] usr3_chid_pb1[35:32]</p>

To get most up-to-date channel ID on four PB ports, write any value to 0x372 to trigger a self update process.

PB CHANNEL ID DEC READ BUS PB1 BYTE 2 - 0X373

Bit	R/W	Default	Description
7:0	R	0x0	<p>CHID_RD_BUS_PB1[31:24]</p> <p>Read CHID_rd_bus_pb1[31:24]. Depend on CHID_RD_SEL_PB1(REG 0X3DE), it read one of six CHID word:</p> <p>0: auto CHID [7:0] auto_chid_pb1[31:24] 1: detection CHID1 [7:0] det1_chid_pb1[31:24] 2: detection CHID2 [7:0] det2_chid_pb1[31:24] 3: Motion detection CHID1 [7:0] det3_chid_pb1[31:24] 4: Motion detection CHID1 [7:0] det4_chid_pb1[31:24] 5: Motion detection CHID1 [7:0] det5_chid_pb1[31:24] 6: Motion detection CHID1 [7:0] det6_chid_pb1[31:24] 7: Motion detection CHID1 [7:0] det7_chid_pb1[31:24] 8: Motion detection CHID1 [7:0] det8_chid_pb1[31:24] 9: user CHID1 [7:0] usr1_chid_pb1[31:24] a: user CHID2 [7:0] usr2_chid_pb1[31:24] b: user CHID3 [7:0] usr3_chid_pb1[31:24]</p>

PB CHANNEL ID DEC READ BUS PB1 BYTE 3 – 0X374

Bit	R/W	Default	Description
7:0	R	0x7	<p>CHID_RD_BUS_PB1[23:16]</p> <p>Read CHID_rd_bus_pb1[23:16]. Depend on CHID_RD_SEL_PB1(REG 0X3DE), it read one of six CHID word:</p> <p>0: auto CHID [7:0] auto_chid_pb1[23:16]</p> <p>1: detection CHID1 [7:0] det1_chid_pb1[23:16]</p> <p>2: detection CHID2 [7:0] det2_chid_pb1[23:16]</p> <p>3: Motion detection CHID1 [7:0] det3_chid_pb1[23:16]</p> <p>4: Motion detection CHID1 [7:0] det4_chid_pb1[23:16]</p> <p>5: Motion detection CHID1 [7:0] det5_chid_pb1[23:16]</p> <p>6: Motion detection CHID1 [7:0] det6_chid_pb1[23:16]</p> <p>7: Motion detection CHID1 [7:0] det7_chid_pb1[23:16]</p> <p>8: Motion detection CHID1 [7:0] det8_chid_pb1[23:16]</p> <p>9: user CHID1 [7:0] usr1_chid_pb1[23:16]</p> <p>a: user CHID2 [7:0] usr2_chid_pb1[23:16]</p> <p>b: user CHID3 [7:0] usr3_chid_pb1[23:16]</p>

PB CHANNEL ID DEC READ BUS PB1 BYTE 4 – 0X3C7

Bit	R/W	Default	Description
7:0	R	0x7	<p>CHID_RD_BUS_PB1[15:8]</p> <p>Read CHID_rd_bus_pb1[15:8]. Depend on CHID_RD_SEL_PB1(REG 0X3DE), it read one of six CHID word:</p> <p>0: auto CHID [7:0] auto_chid_pb1[15:8]</p> <p>1: detection CHID1 [7:0] det1_chid_pb1[15:8]</p> <p>2: detection CHID2 [7:0] det2_chid_pb1[15:8]</p> <p>3: Motion detection CHID1 [7:0] det3_chid_pb1[15:8]</p> <p>4: Motion detection CHID1 [7:0] det4_chid_pb1[15:8]</p> <p>5: Motion detection CHID1 [7:0] det5_chid_pb1[15:8]</p> <p>6: Motion detection CHID1 [7:0] det6_chid_pb1[15:8]</p> <p>7: Motion detection CHID1 [7:0] det7_chid_pb1[15:8]</p> <p>8: Motion detection CHID1 [7:0] det8_chid_pb1[15:8]</p>

Bit	R/W	Default	Description
			9: user CHID1 [7:0] usr1_chid_pb1[15:8] a: user CHID2 [7:0] usr2_chid_pb1[15:8] b: user CHID3 [7:0] usr3_chid_pb1[15:8]

PB CHANNEL ID DEC READ BUS PB1 BYTE 5 – 0X3C8

Bit	R/W	Default	Description
7:0	R	0x7	CHID_RD_BUS_PB1[7:0] Read CHID_rd_bus_pb1[7:0]. Depend on CHID_RD_SEL_PB1(REG 0X3DE), it read one of six CHID word: 0: auto CHID [7:0] auto_chid_pb1[7:0] 1: detection CHID1 [7:0] det1_chid_pb1[7:0] 2: detection CHID2 [7:0] det2_chid_pb1[7:0] 3: Motion detection CHID1 [7:0] det3_chid_pb1[7:0] 4: Motion detection CHID1 [7:0] det4_chid_pb1[7:0] 5: Motion detection CHID1 [7:0] det5_chid_pb1[7:0] 6: Motion detection CHID1 [7:0] det6_chid_pb1[7:0] 7: Motion detection CHID1 [7:0] det7_chid_pb1[7:0] 8: Motion detection CHID1 [7:0] det8_chid_pb1[7:0] 9: user CHID1 [7:0] usr1_chid_pb1[7:0] a: user CHID2 [7:0] usr2_chid_pb1[7:0] b: user CHID3 [7:0] usr3_chid_pb1[7:0]

Video Write Buffer (RGBW)

Introduction

TW2880 has incorporated 32 write buffers to support 16 live video channels and 16 playback channels. Each channel has its own registers for users to adjust window width, height, starting positions and orientations. Each live channel can support up to D1 size while for playback channel the resolution can go up to HD (1920x1080). One thing to remember is in this HD configuration, only two windows are available. All write requests from the buffers will be summed up and prioritized in the multiplex unit and later sent to SDRAM controller. Each channel need to be programmed to write to different locations in SDRAM.

Window Control

Each window in the display path has its own set of control. It can be enabled and disable. The height, width and the starting position of the window is adjustable. User can mirror the image horizontally or vertically to compensate the position of the camera. Cropping is also supported if the display window size is smaller than the incoming signal. One thing to be remembered is windows cannot be overlapped otherwise artifact will appear in the display area.

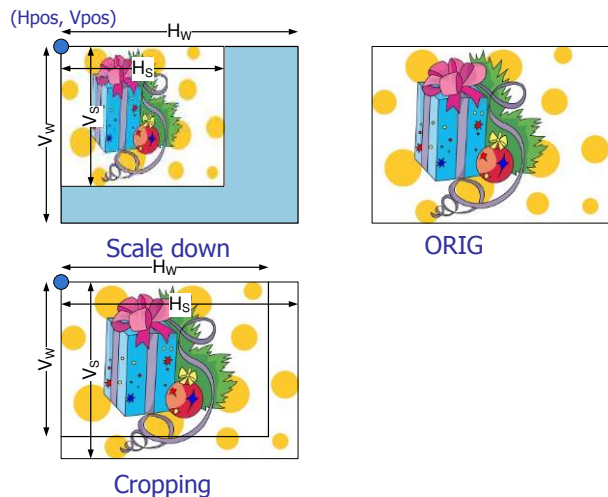

Display Map Control

When updating video information, all channels are writing into the same bank of display memory. When display controller read data, it will read out the data sequentially. The bank control of the reading and writing controller is handled by Frame Rate Control Module (FRSC) and is discussed in detailed in later sections.

The off-screen memory is used by OSG and OSD module. TW2880 has a different display map control when 3D de-interlacing and 2D de-interlacing is deployed.

Display Plane Mapping (128Mx2)

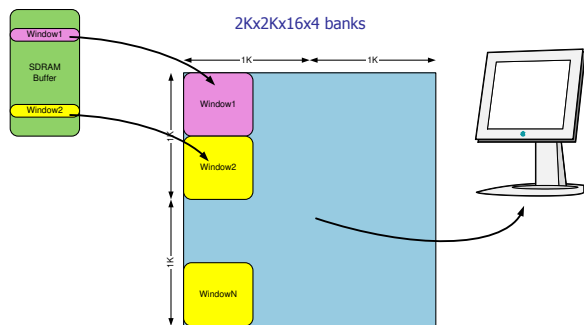

Play Back Channels

Play back channels can support several modes, such as interlaced or progressive. And also for one play back port, different formats can be support in different frames, such as D1, half D1, CIF and Quad. And also different channels being in one port is possible. Data rate in play back channel can be 27MHz, 54MHz or 108MHz. In BT1120 case, clock can be 74.25MHz. Here is an example for one play back port.

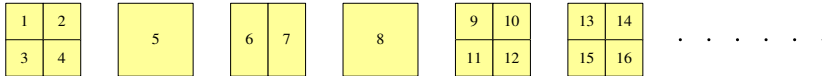

Playback write control unit can write different channels to different location in SDRAM. User can set size and location register for different channels. There are total 16 groups of register for play back channels. These registers share address with live channels. Channel number and format information is given by play back channel ID decoder unit.

If play back port has only one channel and data rate is 27MHz, it can be set to normal write buffer mode. In normal mode, channel number is not used.

In summary, playback write control unit can support two mode: auto mode and normal mode. In auto mode, channel data will be written to different location according to channel number. In normal mode, channel data will be written to one location according to port number.

Register Table

Address	R/W	Default	Description
0x600	R/W	0	rgb_wr_ctrl0 [3]: freeze0 [2]: wr_en0 [1]: hinv0 [0]: vinv0
0x601	R/W	0	rgb_wr_ctrl1 [3]: freeze1 [2]: wr_en1 [1]: hinv1 [0]: vinv1
0x602	R/W	0	rgb_wr_ctrl2 [3]: freeze2 [2]: wr_en2 [1]: hinv2 [0]: vinv2
0x603	R/W	0	rgb_wr_ctrl3 [3]: freeze3 [2]: wr_en3 [1]: hinv3 [0]: vinv3
0x604	R/W	0	rgb_wr_ctrl4 [3]: freeze4 [2]: wr_en4 [1]: hinv4 [0]: vinv4
0x605	R/W	0	rgb_wr_ctrl5 [3]: freeze5 [2]: wr_en5 [1]: hinv5 [0]: vinv5
0x606	R/W	0	rgb_wr_ctrl6 [3]: freeze6 [2]: wr_en6 [1]: hinv6 [0]: vinv6
0x607	R/W	0	rgb_wr_ctrl7 [3]: freeze7 [2]: wr_en7 [1]: hinv7 [0]: vinv7
0x608	R/W	0	rgb_wr_ctrl8 [3]: freeze8 [2]: wr_en8 [1]: hinv8 [0]: vinv8
0x609	R/W	0	rgb_wr_ctrl9 [3]: freeze9 [2]: wr_en9 [1]: hinv9 [0]: vinv9

Address	R/W	Default	Description
0x60A	R/W	0	rgb_wr_ctrl10 [3]: freeze10 [2]: wr_en10 [1]: hin10 [0]: vin10
0x60B	R/W	0	rgb_wr_ctrl11 [3]: freeze11 [2]: wr_en11 [1]: hin11 [0]: vin11
0x60C	R/W	0	rgb_wr_ctrl12 [3]: freeze12 [2]: wr_en12 [1]: hin12 [0]: vin12
0x60D	R/W	0	rgb_wr_ctrl13 [3]: freeze13 [2]: wr_en13 [1]: hin13 [0]: vin13
0x60E	R/W	0	rgb_wr_ctrl14 [3]: freeze14 [2]: wr_en14 [1]: hin14 [0]: vin14
0x60F	R/W	0	rgb_wr_ctrl15 [3]: freeze15 [2]: wr_en15 [1]: hin15 [0]: vin15
0x610	R/W	0	rgb_wr_ctrl16 [3]: freeze16 [2]: wr_en16 [1]: hin16 [0]: vin16
0x611	R/W	0	rgb_wr_ctrl17 [3]: freeze17 [2]: wr_en17 [1]: hin17 [0]: vin17
0x612	R/W	0	rgb_wr_ctrl18 [3]: freeze18 [2]: wr_en18 [1]: hin18 [0]: vin18
0x613	R/W	0	rgb_wr_ctrl19 [3]: freeze19 [2]: wr_en19 [1]: hin19 [0]: vin19
0x614	R/W	0	rgb_vpos0_live[7:0] / rgb_vpos0_pb[7:0]
0x615	R/W	0	rgb_vpos0_live[11:8] / rgb_vpos0_pb[11:8]
0x616	R/W	0	rgb_vpos1_live[7:0] / rgb_vpos1_pb[7:0]
0x617	R/W	0	rgb_vpos1_live[11:8] / rgb_vpos1_pb[11:8]
0x618	R/W	0	rgb_vpos2_live[7:0] / rgb_vpos2_pb[7:0]

Address	R/W	Default	Description
0x619	R/W	0	rgb_vpos2_live[11:8] / rgb_vpos2_pb[11:8]
0x61A	R/W	0	rgb_vpos3_live[7:0] / rgb_vpos3_pb[7:0]
0x61B	R/W	0	rgb_vpos3_live[11:8] / rgb_vpos3_pb[11:8]
0x61C	R/W	0	rgb_vpos4_live[7:0] / rgb_vpos4_pb[7:0]
0x61D	R/W	0	rgb_vpos4_live[11:8] / rgb_vpos4_pb[11:8]
0x61E	R/W	0	rgb_vpos5_live[7:0] / rgb_vpos5_pb[7:0]
0x61F	R/W	0	rgb_vpos5_live[11:8] / rgb_vpos5_pb[11:8]
0x620	R/W	0	rgb_vpos6_live[7:0] / rgb_vpos6_pb[7:0]
0x621	R/W	0	rgb_vpos6_live[11:8] / rgb_vpos6_pb[11:8]
0x622	R/W	0	rgb_vpos7_live[7:0] / rgb_vpos7_pb[7:0]
0x623	R/W	0	rgb_vpos7_live[11:8] / rgb_vpos7_pb[11:8]
0x624	R/W	0	rgb_vpos8_live[7:0] / rgb_vpos8_pb[7:0]
0x625	R/W	0	rgb_vpos8_live[11:8] / rgb_vpos8_pb[11:8]
0x626	R/W	0	rgb_vpos9_live[7:0] / rgb_vpos9_pb[7:0]
0x627	R/W	0	rgb_vpos9_live[11:8] / rgb_vpos9_pb[11:8]
0x628	R/W	0	rgb_vpos10_live[7:0] / rgb_vpos10_pb[7:0]
0x629	R/W	0	rgb_vpos10_live[11:8] / rgb_vpos10_pb[11:8]
0x62A	R/W	0	rgb_vpos11_live[7:0] / rgb_vpos11_pb[7:0]
0x62B	R/W	0	rgb_vpos11_live[11:8] / rgb_vpos11_pb[11:8]
0x62C	R/W	0	rgb_vpos12_live[7:0] / rgb_vpos12_pb[7:0]
0x62D	R/W	0	rgb_vpos12_live[11:8] / rgb_vpos12_pb[11:8]
0x62E	R/W	0	rgb_vpos13_live[7:0] / rgb_vpos13_pb[7:0]
0x62F	R/W	0	rgb_vpos13_live[11:8] / rgb_vpos13_pb[11:8]
0x630	R/W	0	rgb_vpos14_live[7:0] / rgb_vpos14_pb[7:0]
0x631	R/W	0	rgb_vpos14_live[11:8] / rgb_vpos14_pb[11:8]
0x632	R/W	0	rgb_vpos15_live[7:0] / rgb_vpos15_pb[7:0]
0x633	R/W	0	rgb_vpos15_live[11:8] / rgb_vpos15_pb[11:8]
0x634	R/W	0	rgb_vpos16_pb[7:0]
0x635	R/W	0	rgb_vpos16_pb[11:8]
0x636	R/W	0	rgb_vpos17_pb[7:0]
0x637	R/W	0	rgb_vpos17_pb[11:8]
0x638	R/W	0	rgb_vpos18_pb[7:0]
0x639	R/W	0	rgb_vpos18_pb[11:8]
0x63A	R/W	0	rgb_vpos19_pb[7:0]
0x63B	R/W	0	rgb_vpos19_pb[11:8]
0x63C	R/W	0	rgb_vsize0_live[7:0] / rgb_vsize0_pb[7:0]
0x63D	R/W	0	rgb_vsize0_live[10:8] / rgb_vsize0_pb[10:8]
0x63E	R/W	0	rgb_vsize1_live[7:0] / rgb_vsize1_pb[7:0]
0x63F	R/W	0	rgb_vsize1_live[10:8] / rgb_vsize1_pb[10:8]
0x640	R/W	0	rgb_vsize2_live[7:0] / rgb_vsize2_pb[7:0]
0x641	R/W	0	rgb_vsize2_live[10:8] / rgb_vsize2_pb[10:8]
0x642	R/W	0	rgb_vsize3_live[7:0] / rgb_vsize3_pb[7:0]
0x643	R/W	0	rgb_vsize3_live[10:8] / rgb_vsize3_pb[10:8]
0x644	R/W	0	rgb_vsize4_live[7:0] / rgb_vsize4_pb[7:0]
0x645	R/W	0	rgb_vsize4_live[10:8] / rgb_vsize4_pb[10:8]
0x646	R/W	0	rgb_vsize5_live[7:0] / rgb_vsize5_pb[7:0]
0x647	R/W	0	rgb_vsize5_live[10:8] / rgb_vsize5_pb[10:8]
0x648	R/W	0	rgb_vsize6_live[7:0] / rgb_vsize6_pb[7:0]
0x649	R/W	0	rgb_vsize6_live[10:8] / rgb_vsize6_pb[10:8]
0x64A	R/W	0	rgb_vsize7_live[7:0] / rgb_vsize7_pb[7:0]
0x64B	R/W	0	rgb_vsize7_live[10:8] / rgb_vsize7_pb[10:8]
0x64C	R/W	0	rgb_vsize8_live[7:0] / rgb_vsize8_pb[7:0]

Address	R/W	Default	Description
0x64D	R/W	0	rgb_vsize8_live[10:8] / rgb_vsize8_pb[10:8]
0x64E	R/W	0	rgb_vsize9_live[7:0] / rgb_vsize9_pb[7:0]
0x64F	R/W	0	rgb_vsize9_live[10:8] / rgb_vsize9_pb[10:8]
0x650	R/W	0	rgb_vsize10_live[7:0] / rgb_vsize10_pb[7:0]
0x651	R/W	0	rgb_vsize10_live[10:8] / rgb_vsize10_pb[10:8]
0x652	R/W	0	rgb_vsize11_live[7:0] / rgb_vsize11_pb[7:0]
0x653	R/W	0	rgb_vsize11_live[10:8] / rgb_vsize11_pb[10:8]
0x654	R/W	0	rgb_vsize12_live[7:0] / rgb_vsize12_pb[7:0]
0x655	R/W	0	rgb_vsize12_live[10:8] / rgb_vsize12_pb[10:8]
0x656	R/W	0	rgb_vsize13_live[7:0] / rgb_vsize13_pb[7:0]
0x657	R/W	0	rgb_vsize13_live[10:8] / rgb_vsize13_pb[10:8]
0x658	R/W	0	rgb_vsize14_live[7:0] / rgb_vsize14_pb[7:0]
0x659	R/W	0	rgb_vsize14_live[10:8] / rgb_vsize14_pb[10:8]
0x65A	R/W	0	rgb_vsize15_live[7:0] / rgb_vsize15_pb[7:0]
0x65B	R/W	0	rgb_vsize15_live[10:8] / rgb_vsize15_pb[10:8]
0x65C	R/W	0	rgb_vsize16_pb[7:0]
0x65D	R/W	0	rgb_vsize16_pb[10:8]
0x65E	R/W	0	rgb_vsize17_pb[7:0]
0x65F	R/W	0	rgb_vsize17_pb[10:8]
0x660	R/W	0	rgb_vsize18_pb[7:0]
0x661	R/W	0	rgb_vsize18_pb[10:8]
0x662	R/W	0	rgb_vsize19_pb[7:0]
0x663	R/W	0	rgb_vsize19_pb[10:8]
0x664	R/W	0	rgb_hpos0_live[7:0] / rgb_hpos0_pb[7:0]
0x665	R/W	0	rgb_hpos0_live[9:8] / rgb_hpos0_pb[9:8]
0x666	R/W	0	rgb_hpos1_live[7:0] / rgb_hpos1_pb[7:0]
0x667	R/W	0	rgb_hpos1_live[9:8] / rgb_hpos1_pb[9:8]
0x668	R/W	0	rgb_hpos2_live[7:0] / rgb_hpos2_pb[7:0]
0x669	R/W	0	rgb_hpos2_live[9:8] / rgb_hpos2_pb[9:8]
0x66A	R/W	0	rgb_hpos3_live[7:0] / rgb_hpos3_pb[7:0]
0x66B	R/W	0	rgb_hpos3_live[9:8] / rgb_hpos3_pb[9:8]
0x66C	R/W	0	rgb_hpos4_live[7:0] / rgb_hpos4_pb[7:0]
0x66D	R/W	0	rgb_hpos4_live[9:8] / rgb_hpos4_pb[9:8]
0x66E	R/W	0	rgb_hpos5_live[7:0] / rgb_hpos5_pb[7:0]
0x66F	R/W	0	rgb_hpos5_live[9:8] / rgb_hpos5_pb[9:8]
0x670	R/W	0	rgb_hpos6_live[7:0] / rgb_hpos6_pb[7:0]
0x671	R/W	0	rgb_hpos6_live[9:8] / rgb_hpos6_pb[9:8]
0x672	R/W	0	rgb_hpos7_live[7:0] / rgb_hpos7_pb[7:0]
0x673	R/W	0	rgb_hpos7_live[9:8] / rgb_hpos7_pb[9:8]
0x674	R/W	0	rgb_hpos8_live[7:0] / rgb_hpos8_pb[7:0]
0x675	R/W	0	rgb_hpos8_live[9:8] / rgb_hpos8_pb[9:8]
0x676	R/W	0	rgb_hpos9_live[7:0] / rgb_hpos9_pb[7:0]
0x677	R/W	0	rgb_hpos9_live[9:8] / rgb_hpos9_pb[9:8]
0x678	R/W	0	rgb_hpos10_live[7:0] / rgb_hpos10_pb[7:0]
0x679	R/W	0	rgb_hpos10_live[9:8] / rgb_hpos10_pb[9:8]
0x67A	R/W	0	rgb_hpos11_live[7:0] / rgb_hpos11_pb[7:0]
0x67B	R/W	0	rgb_hpos11_live[9:8] / rgb_hpos11_pb[9:8]
0x67C	R/W	0	rgb_hpos12_live[7:0] / rgb_hpos12_pb[7:0]
0x67D	R/W	0	rgb_hpos12_live[9:8] / rgb_hpos12_pb[9:8]
0x67E	R/W	0	rgb_hpos13_live[7:0] / rgb_hpos13_pb[7:0]
0x67F	R/W	0	rgb_hpos13_live[9:8] / rgb_hpos13_pb[9:8]
0x680	R/W	0	rgb_hpos14_live[7:0] / rgb_hpos14_pb[7:0]

Address	R/W	Default	Description
0x681	R/W	0	rgb_hpos14_live[9:8] / rgb_hpos14_pb[9:8]
0x682	R/W	0	rgb_hpos15_live[7:0] / rgb_hpos15_pb[7:0]
0x683	R/W	0	rgb_hpos15_live[9:8] / rgb_hpos15_pb[9:8]
0x684	R/W	0	rgb_hpos16_pb[7:0]
0x685	R/W	0	rgb_hpos16_pb[9:8]
0x686	R/W	0	rgb_hpos17_pb[7:0]
0x687	R/W	0	rgb_hpos17_pb[9:8]
0x688	R/W	0	rgb_hpos18_pb[7:0]
0x689	R/W	0	rgb_hpos18_pb[9:8]
0x68A	R/W	0	rgb_hpos19_pb[7:0]
0x68B	R/W	0	rgb_hpos19_pb[9:8]
0x68C	R/W	0	rgb_hsize0_live[7:0] / rgb_hsize0_pb[7:0]
0x68D	R/W	0	rgb_hsize0_live[8] / rgb_hsize0_pb[8]
0x68E	R/W	0	rgb_hsize1_live[7:0] / rgb_hsize1_pb[7:0]
0x68F	R/W	0	rgb_hsize1_live[8] / rgb_hsize1_pb[8]
0x690	R/W	0	rgb_hsize2_live[7:0] / rgb_hsize2_pb[7:0]
0x691	R/W	0	rgb_hsize2_live[8] / rgb_hsize2_pb[8]
0x692	R/W	0	rgb_hsize3_live[7:0] / rgb_hsize3_pb[7:0]
0x693	R/W	0	rgb_hsize3_live[8] / rgb_hsize3_pb[8]
0x694	R/W	0	rgb_hsize4_live[7:0] / rgb_hsize4_pb[7:0]
0x695	R/W	0	rgb_hsize4_live[8] / rgb_hsize4_pb[8]
0x696	R/W	0	rgb_hsize5_live[7:0] / rgb_hsize5_pb[7:0]
0x697	R/W	0	rgb_hsize5_live[8] / rgb_hsize5_pb[8]
0x698	R/W	0	rgb_hsize6_live[7:0] / rgb_hsize6_pb[7:0]
0x699	R/W	0	rgb_hsize6_live[8] / rgb_hsize6_pb[8]
0x69A	R/W	0	rgb_hsize7_live[7:0] / rgb_hsize7_pb[7:0]
0x69B	R/W	0	rgb_hsize7_live[8] / rgb_hsize7_pb[8]
0x69C	R/W	0	rgb_hsize8_live[7:0] / rgb_hsize8_pb[7:0]
0x69D	R/W	0	rgb_hsize8_live[8] / rgb_hsize8_pb[8]
0x69E	R/W	0	rgb_hsize9_live[7:0] / rgb_hsize9_pb[7:0]
0x69F	R/W	0	rgb_hsize9_live[8] / rgb_hsize9_pb[8]
0x6A0	R/W	0	rgb_hsize10_live[7:0] / rgb_hsize10_pb[7:0]
0x6A1	R/W	0	rgb_hsize10_live[8] / rgb_hsize10_pb[8]
0x6A2	R/W	0	rgb_hsize11_live[7:0] / rgb_hsize11_pb[7:0]
0x6A3	R/W	0	rgb_hsize11_live[8] / rgb_hsize11_pb[8]
0x6A4	R/W	0	rgb_hsize12_live[7:0] / rgb_hsize12_pb[7:0]
0x6A5	R/W	0	rgb_hsize12_live[8] / rgb_hsize12_pb[8]
0x6A6	R/W	0	rgb_hsize13_live[7:0] / rgb_hsize13_pb[7:0]
0x6A7	R/W	0	rgb_hsize13_live[8] / rgb_hsize13_pb[8]
0x6A8	R/W	0	rgb_hsize14_live[7:0] / rgb_hsize14_pb[7:0]
0x6A9	R/W	0	rgb_hsize14_live[8] / rgb_hsize14_pb[8]
0x6AA	R/W	0	rgb_hsize15_live[7:0] / rgb_hsize15_pb[7:0]
0x6AB	R/W	0	rgb_hsize15_live[8] / rgb_hsize15_pb[8]
0x6AC	R/W	0	rgb_hsize16_pb[7:0]
0x6AD	R/W	0	rgb_hsize16_pb[8]
0x6AE	R/W	0	rgb_hsize17_pb[7:0]
0x6AF	R/W	0	rgb_hsize17_pb[8]
0x6B0	R/W	0	rgb_hsize18_pb[7:0]
0x6B1	R/W	0	rgb_hsize18_pb[8]
0x6B2	R/W	0	rgb_hsize19_pb[7:0]
0x6B3	R/W	0	rgb_hsize19_pb[8]

Address	R/W	Default	Description
0x6B4	R/W	0	[7:4]: newfld_sel [3]: mode [2]: TST_IN_PB [1]: PALNT [0]: TST_IN
0x6B5	R/W	0	Test_timing_replace[7:0]
0x6B6	R/W	0	[7]: line_bigger_en_pb [6]: line_bigger_en [5]: use_novid [4:3]: skip_sel [2]: prot_en [1]: CHID_sel [0]: live_pb
0x6B7	R/W	0	[7:4]: pb1_chnum [3:0]: pb0_chnum
0x6B8	R/W	0	[7:4]: pb3_chnum [3:0]: pb2_chnum
0x6B9	R/W	0	[7:6]: IGNON_NON-STANDRED[1:0] [5]: NON-STANDRED_IRQ_MASK [4]: read select [3:0]: pb3_chnum_en - pb0_chnum_en
0x6BA	R/W	0	Test_timing_replace[15:8]
0x6BB	R/W	0	Pb_ch_frez[7:0]
0x6BC	R/W	0	Pb_ch_frez[15:8]
0x6BD	R/W	0	Prot_addr[7:0]
0x6BE	R/W	0	Prot_addr[15:8]
0x6BF	R/W	0	Prot_addr[21:16]
0x6C0	R/W	0	rgb_hstart0_live[7:0] / rgb_hstart0_pb[7:0]
0x6C1	R/W	0	rgb_hstart1_live[7:0] / rgb_hstart1_pb[7:0]
0x6C2	R/W	0	rgb_hstart2_live[7:0] / rgb_hstart2_pb[7:0]
0x6C3	R/W	0	rgb_hstart3_live[7:0] / rgb_hstart3_pb[7:0]
0x6C4	R/W	0	rgb_hstart4_live[7:0] / rgb_hstart4_pb[7:0]
0x6C5	R/W	0	rgb_hstart5_live[7:0] / rgb_hstart5_pb[7:0]
0x6C6	R/W	0	rgb_hstart6_live[7:0] / rgb_hstart6_pb[7:0]
0x6C7	R/W	0	rgb_hstart7_live[7:0] / rgb_hstart7_pb[7:0]
0x6C8	R/W	0	rgb_hstart8_live[7:0] / rgb_hstart8_pb[7:0]
0x6C9	R/W	0	rgb_hstart9_live[7:0] / rgb_hstart9_pb[7:0]
0x6CA	R/W	0	rgb_hstart10_live[7:0] / rgb_hstart10_pb[7:0]
0x6CB	R/W	0	rgb_hstart11_live[7:0] / rgb_hstart11_pb[7:0]
0x6CC	R/W	0	rgb_hstart12_live[7:0] / rgb_hstart12_pb[7:0]
0x6CD	R/W	0	rgb_hstart13_live[7:0] / rgb_hstart13_pb[7:0]
0x6CE	R/W	0	rgb_hstart14_live[7:0] / rgb_hstart14_pb[7:0]
0x6CF	R/W	0	rgb_hstart15_live[7:0] / rgb_hstart15_pb[7:0]
0x6D0	R/W	0	rgb_hstart16_pb[7:0]
0x6D1	R/W	0	rgb_hstart17_pb[7:0]
0x6D2	R/W	0	rgb_hstart18_pb[7:0]
0x6D3	R/W	0	rgb_hstart19_pb[7:0]
0x6D4	R/W	0	rgb_vstart0_live[7:0] / rgb_vstart0_pb[7:0]
0x6D5	R/W	0	rgb_vstart1_live[7:0] / rgb_vstart1_pb[7:0]
0x6D6	R/W	0	rgb_vstart2_live[7:0] / rgb_vstart2_pb[7:0]
0x6D7	R/W	0	rgb_vstart3_live[7:0] / rgb_vstart3_pb[7:0]
0x6D8	R/W	0	rgb_vstart4_live[7:0] / rgb_vstart4_pb[7:0]
0x6D9	R/W	0	rgb_vstart5_live[7:0] / rgb_vstart5_pb[7:0]

Address	R/W	Default	Description
0x6DA	R/W	0	rgb_vstart6_live[7:0] / rgb_vstart6_pb[7:0]
0x6DB	R/W	0	rgb_vstart7_live[7:0] / rgb_vstart7_pb[7:0]
0x6DC	R/W	0	rgb_vstart8_live[7:0] / rgb_vstart8_pb[7:0]
0x6DD	R/W	0	rgb_vstart9_live[7:0] / rgb_vstart9_pb[7:0]
0x6DE	R/W	0	rgb_vstart10_live[7:0] / rgb_vstart10_pb[7:0]
0x6DF	R/W	0	rgb_vstart11_live[7:0] / rgb_vstart11_pb[7:0]
0x6E0	R/W	0	rgb_vstart12_live[7:0] / rgb_vstart12_pb[7:0]
0x6E1	R/W	0	rgb_vstart13_live[7:0] / rgb_vstart13_pb[7:0]
0x6E2	R/W	0	rgb_vstart14_live[7:0] / rgb_vstart14_pb[7:0]
0x6E3	R/W	0	rgb_vstart15_live[7:0] / rgb_vstart15_pb[7:0]
0x6E4	R/W	0	rgb_vstart16_pb[7:0]
0x6E5	R/W	0	rgb_vstart17_pb[7:0]
0x6E6	R/W	0	rgb_vstart18_pb[7:0]
0x6E7	R/W	0	rgb_vstart19_pb[7:0]
0x6E8	R/W	0	Live port 1, 0 correction control
0x6E9	R/W	0	Live port 3, 2 correction control
0x6EA	R/W	0	Live port 5, 4 correction control
0x6EB	R/W	0	Live port 7, 6 correction control
0x6EC	R/W	0	Live port 9, 8 correction control
0x6ED	R/W	0	Live port 11, 10 correction control
0x6EE	R/W	0	Live port 13, 12 correction control
0x6EF	R/W	0	Live port 15, 14 correction control
0x6F0	RO	0	linenum_pb0[7:0]
0x6F1	RO	0	linenum_pb0[11:8]
0x6F0	RW	0	PB port 1, 0 correction control, shared
0x6F1	RW	0	PB port 3, 2 correction control, shared
0x6F2	RO	0	linenum_pb1[7:0]
0x6F3	RO	0	linenum_pb1[11:8]
0x6F4	RO	0	linenum_pb2[7:0]
0x6F5	RO	0	linenum_pb2[11:8]
0x6F6	RO	0	linenum_pb3[7:0]
0x6F7	RO	0	linenum_pb3[11:8]
0x6F8	R/W	0	[7]: write to clear [3:0]: pb3_valid - pb0_valid
0x6F9	R/W	0	[7:0]: period2 external correction period
0x6FA	R/W	0	[7:4]: Enable ignore function [3:0]: pb_free_3 - pb_free_0
0x6FB	R/W	0x1C	[7:4]: fifo_cnt_limit [3]: fld_update [2]: fld_sel_fix [1]: fld_sel_en [0]: vstart_unit_pb
0x6FC	R/W	0	[7:6]: address select [5]: Force live use old method [4]: seld [3:2]: reserved [1]: hstart_unit_pb, 1= 8 pixels [0]: vinv_sel
0x6FD	R/W	0	pb_ch_en[7:0]
0x6FE	R/W	0	pb_ch_en[15:8]
0x6FF	R/W	0	period[7:0] internal correction period

Register

DISPLAY WRITE BUFFER CONTROL REGISTER – 0X600

Bit	R/W	Default	Description
7:4	R	0	Reserved
3	R/W	0	Freeze 1 = Enable 0 = Disable
2	R/W	0	Buffer Operation 1 = Enable 0 = Disable
1	R/W	0	Horizontal Inversion 1 = Enable 0 = Disable
0	R/W	0	Vertical Inversion 1 = Enable 0 = Disable

Similar registers are assigned to control Display Write Buffer 2 to 20 using register 0x601 – 0x613 respectively.

DISPLAY WRITE BUFFER VERTICAL POSITION REGISTER A – 0X614

Bit	R/W	Default	Description
7:0	R/W	0	Vertical Position[7:0]

DISPLAY WRITE BUFFER VERTICAL POSITION REGISTER B – 0X615

Bit	R/W	Default	Description
7:4	R	0	Reserved
3:0	R/W	0	Vertical Position[11:8]

Similar registers are assigned to control Display Write Buffer 2 to 20 using register 0x616 – 0x63B respectively.

Note: Vertical position must be even number.

In auto mode, when register live_pb (0x6B6) is set to 0, these registers are for live channels. When live_pb is set to 1, these registers are for PB channels. Register rgb_vpos0_pb to rgb_vpos15_pb are used in auto mode. They share address with rgb_vpos0_live to rgb_vpos15_live. Register rgb_vpos16_pb to rgb_vpos19_pb are used in normal mode.

DISPLAY WRITE BUFFER VERTICAL SIZE REGISTER A – 0X63C

Bit	R/W	Default	Description
7:0	R/W	0	Vertical Size[7:0]

DISPLAY WRITE BUFFER VERTICAL SIZE REGISTER B – 0X63D

Bit	R/W	Default	Description
7:3	R	0	Reserved
2:0	R/W	0	Vertical Size[10:8]

Similar registers are assigned to control Display Write Buffer 2 to 20 using register 0x63E – 0x663 respectively.

Vertical size must be even number.

In auto mode, when register `live_pb` (0x6B6) is set to 0, these registers are for live channels. When `live_pb` is set to 1, these registers are for PB channels. Register `rgb_vsize0_pb` to `rgb_vsize15_pb` are used in auto mode. They share address with `rgb_vsize0_live` to `rgb_vsize15_live`. Register `rgb_vsize16_pb` to `rgb_vsize19_pb` are used in normal mode.

DISPLAY WRITE BUFFER HORIZONTAL POSITION REGISTER A – 0X664

Bit	R/W	Default	Description
7:0	R/W	0	Horizontal Position[7:0]l, unit is 4 pixels

DISPLAY WRITE BUFFER HORIZONTAL POSITION REGISTER B – 0X665

Bit	R/W	Default	Description
7:1	R	0	Reserved
0	R/W	0	Horizontal Position[8]

Similar registers are assigned to control Display Write Buffer 2 to 20 using register 0x666 – 0x68B respectively.

In auto mode, when register `live_pb` (0x6B6) is set to 0, these registers are for live channels. When `live_pb` is set to 1, these registers are for PB channels. Register `rgb_hpos0_pb` to `rgb_hpos15_pb` are used in auto mode. They share address with `rgb_hpos0_live` to `rgb_hos15_live`. Register `rgb_hpos16_pb` to `rgb_hpos19_pb` are used in normal mode.

DISPLAY WRITE BUFFER HORIZONTAL SIZE REGISTER A – 0X68C

Bit	R/W	Default	Description
7:0	R/W	0	Horizontal Size[7:0]l, unit is 4 pixels

DISPLAY WRITE BUFFER HORIZONTAL SIZE REGISTER B – 0X68D

Bit	R/W	Default	Description
7:1	R	0	Reserved
0	R/W	0	Horizontal Size[8]

Similar registers are assigned to control Display Write Buffer 2 to 20 using register 0x68E – 0x6B3 respectively.

In auto mode, when register `live_pb` (0x6B6) is set to 0, these registers are for live channels. When `live_pb` is set to 1, these registers are for PB channels. Register `rgb_hsize0_pb` to `rgb_hsize15_pb` are used in auto mode. They share address with `rgb_hsize0_live` to `rgb_hos15_live`. Register `rgb_hsize16_pb` to `rgb_hsize19_pb` are used in normal mode.

DISPLAY WRITE BUFFER CONTROL REGISTER 1 – 0X6B4

Bit	R/W	Default	Description
7:4	R/W	0	Newfld_sel: New field signal for LCD frame rate adjustment. There are total 16 live channels. Only one channel is selected for LCD frame rate adjustment.
3	R/W	0	MODE: This bit set play back channel buffer mode. 1: auto mode, use channel ID information, can support 16 channels in one PB port. 0: normal mode, support only one channel in one PB port
2	R/W	0	TST_IN_PB: Test pattern enable for PB channels
1	R/W	0	PALNT: Test pattern PAL/NTSC selection. 0: NTSC 1: PAL
0	R/W	0	TST_IN: Test pattern enable for live channels

TEST PATTERN TIMING REPLACE REGISTER 1 – 0X6B5

Bit	R/W	Default	Description
7:0	RW	0	TST_PAT_CH[7:0]: This register control live channel [7:0]. If the respective bit is set to "1", write process will use internal test pattern timing instead of camera timing. Set 0x6fc.4 = 1 to read.

MISC CONTROL REGISTER – 0X6B6

Bit	R/W	Default	Description
7	RW	0	Line_bigger_en_pb: This bit cut vertical active signal when input video is crashed
6	RW	0	Line_bigger_en: This bit cut vertical active signal when input video is crashed
5	RW	0	Use_novid: When enable this bit, no video signal from TW2864 will determine write or not.
4:3	RW	0	Skip_sel: Frame drop selection for live videos 00: no frame drop 01: every five frames will drop one frame 10: every six frames will drop one frame 11: every seven frames will drop one frame
2	RW	0	Prot_en When this bit turns on, rgb_interface will not write data to address bigger than prot_addr.
1	RW	0	chid_sel When this bit turn on, channel ID for PB port will be set to 0x0123 for port 0, 0x4567 for port 1, 0x89AB for port 2 and 0xCDEF for port 3. When this bit is 0, channel ID will decode from channel ID area.
0	R/W	0	Live_Pb Select 1: PB channels 0: live channels For register hpos0-15, vpos0-15, hsize0-15, vsize0-15, hstart0-15, vstart0-15, they share same address between live channels and PB channels. If this bit is set to low, live channels values can be read or write. If this bit is set to high, PB channels values can be read or write

PB FIRST CHANNEL NUMBER REGISTER 1 – 0X6B7

Bit	R/W	Default	Description
7:4	RW	0	Pb1_chnum: This is used in frame interleave mode. It should be set to first frame number in PB port 1
3:0	RW	0	Pb0_chnum: This is used in frame interleave mode. It should be set to first frame number in PB port 0

PB FIRST CHANNEL NUMBER REGISTER 2 – 0X6B8

Bit	R/W	Default	Description
7:4	RW	0	Pb3_chnum: This is used in frame interleave mode. It should be set to first frame number in PB port 3
3:0	RW	0	Pb2_chnum: This is used in frame interleave mode. It should be set to first frame number in PB port 2

PB FIRST CHANNEL NUMBER ENABLE REGISTER – 0X6B9

Bit	R/W	Default	Description
7:6	RW	0	IGNOR_NON-STANDRED[1] 0: if non-standard sequence appears, switch to test pattern timing 1: disable the switching, always use original camera timing IGNOR_NON-STANDRED[0] 0: report non-standard video sequence status 1: disable the non-standard status report
5	RW	0	IRQENA_NON-STANDRED: Non-standard interrupt masking bit 0: off (masked) 1: on
4	R/W	0	Read out select 0: normal 1: Read address 0x6f0, 0x6f1 will become the PB correction register
3	RW	0	Pb3_chnum_en: Same as channel 0
2	RW	0	Pb2_chnum_en: Same as channel 0
1	RW	0	Pb1_chnum_en: Same as channel 0
0	RW	0	Pb0_chnum_en: this is used in frame interleave mode. First channel number enable 0: update wr_page any time 1: update wr_page when chnum equals to pb0_chnum

TEST PATTERN TIMING REPLACE REGISTER 2 – 0X6BA

Bit	R/W	Default	Description
7:0	RW	0	TST_PAT_CH[15:8]: This register control live channel [15:8]. If the respective bit is set to "1", write process will use internal test pattern timing instead of camera timing. Set 0x6fc.4 = 1 to read.

PB CHANNEL FREEZE REGISTER 1 – 0X6BB

Bit	R/W	Default	Description
7:0	R/W	0	Pb_ch_frez[7:0] 1: freeze 0: normal operation

PB CHANNEL FREEZE REGISTER 2 – 0X6BC

Bit	R/W	Default	Description
7:0	R/W	0	Pb_ch_frez[15:8]

PROTECTION ADDRESS REGISTER 1 – 0X6BD

Bit	R/W	Default	Description
7:0	R/W	0	Prot_addr[7:0] Protection area. It is 8 bytes unit. RGB interface will not write data to address more than or equal to prot_addr.

PROTECTION ADDRESS REGISTER 2 – 0X6BE

Bit	R/W	Default	Description
7:0	R/W	0	Prot_addr[15:8]

PROTECTION ADDRESS REGISTER 3 – 0X6BF

Bit	R/W	Default	Description
5:0	R/W	0	Prot_addr[21:16]

Register 0x6bd, 0x6be, 0x6bf is controlled by 0x6fc[7:6]. It can be redefined as external OSG address1 and 2.

DISPLAY WRITE BUFFER HORIZONTAL START – 0X6C0

Bit	R/W	Default	Description
7:0	R/W	0	Horizontal Start[7:0] Image horizontal start position used for cropping. Unit is 4 pixels

Similar registers are assigned to control Display Write Buffer 2 to 20 using register 0x6C1 – 0x6D3 respectively.

In auto mode, when register live_pb (0x6B6) bit 0 is set to 0, these registers are for live channels. When live_pb is set to 1, these registers are for PB channels. Register rgb_hstart0_pb to rgb_hstart15_pb are used in auto mode. They share address with rgb_hstart0_live to rgb_hstart15_live. Register rgb_hstart16_pb to rgb_hstart19_pb are used in normal mode.

DISPLAY WRITE BUFFER VERTICAL START – 0X6D4

Bit	R/W	Default	Description
7:0	R/W	0	Vertical Start[7:0] Image vertical start position used for cropping.

Similar registers are assigned to control Display Write Buffer 2 to 20 using register 0x6D5 – 0x6E7 respectively.

In auto mode, when register live_pb (0x6B6) is set to 0, these registers are for live channels. When live_pb is set to 1, these registers are for PB channels. Register rgb_vstart0_pb to rgb_vstart15_pb are used in auto mode. They share address with rgb_vstart0_live to rgb_hos15_live. Register rgb_vstart16_pb to rgb_vstart19_pb are used in normal mode. Unit is 2 lines for live channels. Unit can be changed for PB channels. When vstart_unit_pb is set to 1, the unit is 4 lines. When vstart_unit_pb is set to 0, the unit is 2 lines. In auto mode, vstart for PB has different meaning. Vstart0_pb to vstart3_pb are used for PB port 0. They are for 4 positions in Quad mode. Vstart4_pb to vstart7_pb are used for PB port 1. Vstart8_pb to Vstart11_pb are used for PB port 2. Vstart12_pb to vstart15_pb are used for PB port 3.

LIVE CHANNEL FRAME RATE CORRECTION CONTROL REGISTER 1 – 0X6E8

Bit	R/W	Default	Description
7:4	RW	F	Correction Control[3:0]: This is for channel 1
3:0	RW	F	Correction Control[3:0]: This is for channel 0 Bit 3: 1 = Enable non-standard FRSC correction Bit 2: 1 = Enable non-standard write page correction Bit 1: 1 = Enable external write page correction Bit 0: 1 = Enable internal write page correction

LIVE CHANNEL FRAME RATE CORRECTION CONTROL REGISTER 2 – 0X6E9

Bit	R/W	Default	Description
7:4	RW	F	Correction Control[3:0]: This is for channel 3
3:0	RW	F	Correction Control[3:0]: This is for channel 2

LIVE CHANNEL FRAME RATE CORRECTION CONTROL REGISTER 3 – 0X6EA

Bit	R/W	Default	Description
7:4	RW	F	Correction Control[3:0]: This is for channel 5
3:0	RW	F	Correction Control[3:0]: This is for channel 4

LIVE CHANNEL FRAME RATE CORRECTION CONTROL REGISTER 4 – 0X6EB

Bit	R/W	Default	Description
7:4	RW	F	Correction Control[3:0]: This is for channel 7
3:0	RW	F	Correction Control[3:0]: This is for channel 6

LIVE CHANNEL FRAME RATE CORRECTION CONTROL REGISTER 1 – 0X6EC

Bit	R/W	Default	Description
7:4	RW	F	Correction Control[3:0]: This is for channel 9
3:0	RW	F	Correction Control[3:0]: This is for channel 8

LIVE CHANNEL FRAME RATE CORRECTION CONTROL REGISTER 2 – 0X6ED

Bit	R/W	Default	Description
7:4	RW	F	Correction Control[3:0]: This is for channel 11
3:0	RW	F	Correction Control[3:0]: This is for channel 10

LIVE CHANNEL FRAME RATE CORRECTION CONTROL REGISTER 7 – 0X6EE

Bit	R/W	Default	Description
7:4	RW	F	Correction Control[3:0]: This is for channel 13
3:0	RW	F	Correction Control[3:0]: This is for channel 12

LIVE CHANNEL FRAME RATE CORRECTION CONTROL REGISTER 8 – 0X6EF

Bit	R/W	Default	Description
7:4	RW	F	Correction Control[3:0]: This is for channel 15
3:0	RW	F	Correction Control[3:0]: This is for channel 14

PB0 LINE NUMBER STATUS REGISTER 1 – 0X6F0 (READ ONLY)

Bit	R/W	Default	Description
7:0	RO	-	Linenum_pb0[7:0]: Total line number for PB port 0.

PB0 LINE NUMBER STATUS REGISTER 2 – 0X6F1 (READ ONLY)

Bit	R/W	Default	Description
7:4	RO	0	Reserved
3:0	RO	-	Linenum_pb0[11:8]: Total line number for PB port 0.

Register 0x6F2 to 0x6F7 are port 1 to 3, When 0x6b9[4] = 1, 0x6f0 and 0x6f1 is redefine as PB Correction Control Register.

PB CHANNEL FRAME RATE CORRECTION CONTROL REGISTER 1 – 0X6F0

Bit	R/W	Default	Description
7:4	RW	0x33	Correction Control[3:0]: This is for PB channel 1
3:0	RW	0x33	Correction Control[3:0]: This is for PB channel 0 Bit 3 = Double save mode control (1 = enable) Bit 2 = Select Top or Bottom field (1 = Bottom) Bit 1,0 (Auto mode) 1X = Set compatible mode 01 = Correction enable 00 = Free running Bit1,0 (Normal mode) 0X = Set compatible mode 11 = Correction enable 10 = Free running

PB CHANNEL FRAME RATE CORRECTION CONTROL REGISTER 2 – 0X6F1

Bit	R/W	Default	Description
7:4	RW	0x33	Correction Control[3:0]: This is for PB channel 3
3:0	RW	0x33	Correction Control[3:0]: This is for PB channel 2

PB VALID STATUS REGISTER – 0X6F8

Bit	R/W	Default	Description
7	W	0	Write this bit to clear bit [3:0]
6:4	RO	0	Reserved
3	RO	0	Pb3_valid: Valid signal bit for PB channel 3
2	RO	0	Pb2_valid: Valid signal bit for PB channel 2
1	RO	0	Pb1_valid: Valid signal bit for PB channel 1
0	RO	0	Pb0_valid: This bit will be high if there is valid field signal coming. This bit will be clear when write to this register.

LIVE CHANNEL EXTERNAL CORRECTION PERIOD REGISTER – 0X6F9

Bit	R/W	Default	Description
7:0	R/W	0x25	period2[7:0]: Control the write page self checking period, the unit is the LCD Vsync.

PB CHANNEL IGNORE AND FREE RUNNING REGISTER – 0X6FA

Bit	R/W	Default	Description
7	RW	0	SEL_IG3: Ignore control of channel 3
6	RW	0	SEL_IG2: Ignore control of channel 2
5	RW	0	SEL_IG1: Ignore control of channel 1
4	RW	0	SEL_IG0: Ignore control of channel 0 Set this bit to "1" and PB write buffer will use ignore bits in digital channel ID to determine which channel or channels should be disabled.
3	RW	0	Pb_free_3: Free running control of channel 3
2	RW	0	Pb_free_2: Free running control of channel 2
1	RW	0	Pb_free_1: Free running control of channel 1
0	RW	0	Pb_free_0: Free running control of channel 0 Set this bit to "1", PB video will be free running, write_page will automatically plus 1, frame rate control has no use.

FIFO COUNT LIMIT REGISTER – 0X6FB

Bit	R/W	Default	Description
7:4	RW	1	Fifo_cnt_limit: RGB FIFO count limit.
3	RW	1	Fld_update: In interlaced PB mode, when this bit set to 1, frame buffer only update when last field is even field and current field is odd filed.
2	RW	1	Fld_sel_fix: In progressive PB mode, when fld_sel_en set to 0, fld signal is fixed to setting value: fld_sel_fix.
1	RW	0	Fld_sel_en: In progressive PB mode, when this bit set to 0, fld signal is fixed to setting valued: fld_sel_fix. When this bit set to 1, fld signal is the detected fld signal.
0	RW	0	Vstart_unit_pb: Unit for vstart for pb channels 0: unit is 2 line 1: unit is 4 line, used for BT1120 or 4D1 case

VERTICAL INVERTER METHOD SELECTION – 0X6FC

Bit	R/W	Default	Description
7:6	RW	0	Address Select 00 = Protection address register 01 = External OSG buffer address 1 10 = External OSG buffer address 2 11 = Reserved
5	RW	0	1 = Force live channel to use old frame rate algorithm
4	RW	1	sel: 1 = change the read content of 0x6b5 and 0x6b9
3	R	0	Reserved
2	RW	0	1 = PB and Live with the same priority 0 = Force display arbiter adopt PB has no round robin
1	RW	0	Hstart_unit_pb: Unit for hstart for pb channels 0: unit is 4 pixels 1: unit is 8 pixels, used for BT1120 or 4D1 case
0	RW	0	Vinv_sel: Vertical invert method selection. 0: odd field will write to even field 1: odd field will write to odd field

AUTO MODE PB CHANNEL ENABLE REGISTER 1 – 0X6FD

Bit	R/W	Default	Description
7:0	R/W	0	PB_CH_EN[7:0]: Control auto mode PB channel 7 - 0 1 = Playback channel enable

AUTO MODE PB CHANNEL ENABLE REGISTER 2 – 0X6FE

Bit	R/W	Default	Description
7:0	R/W	0	PB_CH_EN[15:8]: Control auto mode PB channel 15 - 8 1 = Playback channel enable

LIVE CHANNEL INTERNAL CORRECTION PERIOD REGISTER – 0X6FF

Bit	R/W	Default	Description
7:0	R/W	0x5	period[7:0]: Control the write page self checking period, the unit is the incoming channel Vsync.

DRAM Control Unit (DCU)

Introduction

The TW2880's DRAM controller unit provides the necessary bridging for the display path and recording path functional units to get access to the off-chip SDRAM. The recording unit is covered in the recording section of this datasheet. Here, we mainly discuss the memory map and the clients in the display unit. However, the basic functionalities are the same for both controllers. The current display clients are: CPU, RGBW, LCD, Dual monitor and OSG. In these DRAM clients, only CPU and RGBW have the write requirement. The detailed DRAM data bus flow is shown in the chip block diagram.

Memory Organization

TW2880's DCU supports SDRAM subsystem size up to 128 Mbytes by using four 64, 128 or 256 Mbit generation DRAMs with 16 or 32 wide bus. The overall memory bus is 64 bit wide. Although using 32 bit bus is possible, the number of incoming channels to display has to be minimized for reduced memory bandwidth. The operating speed is ranged from 166 MHz to 182 MHz. The sustained bandwidth when running at 166 MHz is $166 * 8 * 0.8 = 1062$ MB/sec.

The internal linear address (LA) is 24 bit and classified as:

$$2^{10} \text{ (Row)} \times 2^9 \text{ (Column)} \times 2^2 \text{ (Page)} \times 2^3 \text{ (64 bit)} = 2^{24}$$

The next table shows the resolutions and memory required.

Item		Total: 16 MB installed
Video	1280 x 1024 x 2 x 4 = 10.48 MB	
OSG	1280 x 1024 x 2 = 2.62 MB	
MISC	3MB	
		Total: 32 MB installed
Video	1680 x 1050 x 2 x 4 = 14.08 MB	
OSG	1680 x 1050 x 2 = 3.52 MB	
MISC		

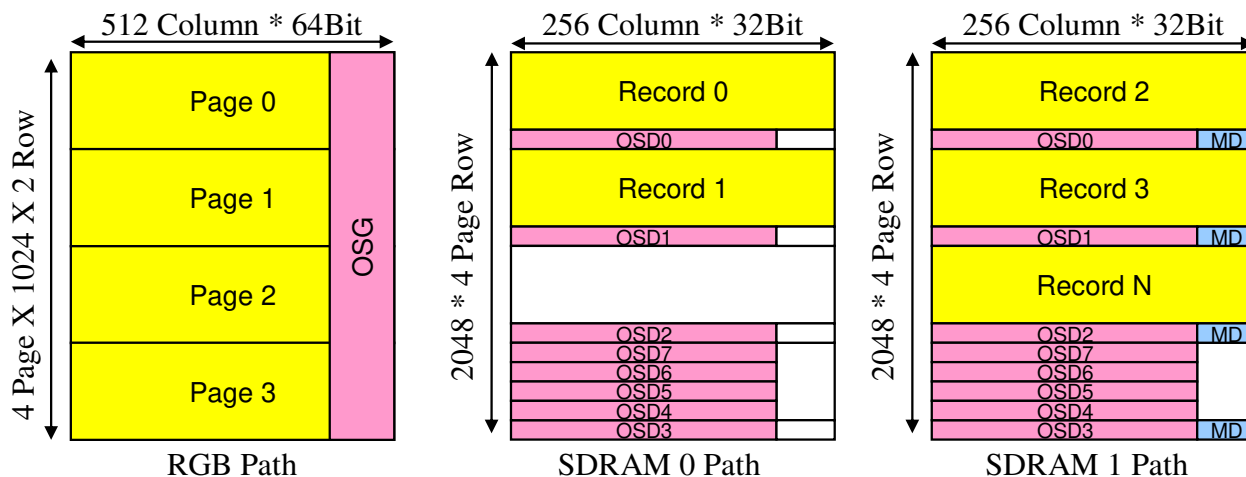

Display Plane and DRAM Arrangement

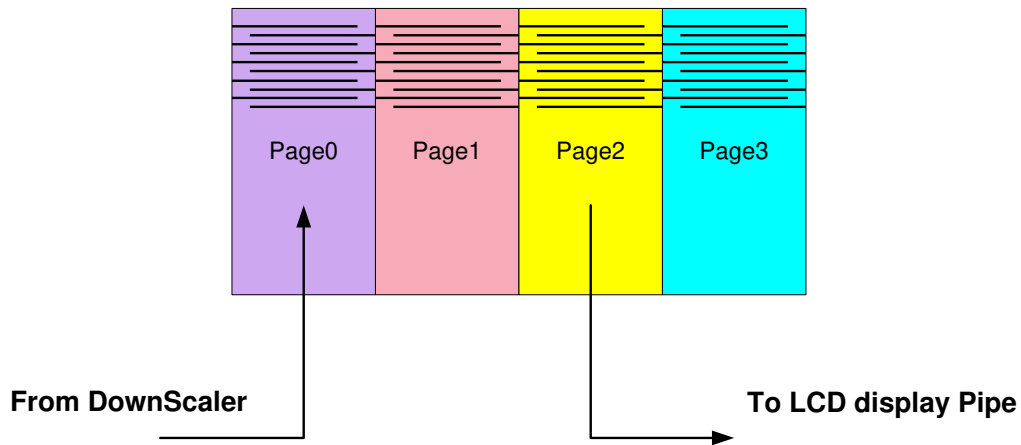

Channel Video Storage Diagram

To prevent video tearing and help simplifying the incoming video field management, TW2880’s display processor is storing four incoming video frame (8 fields) into the DRAM. A frame rate synchronization circuit (FRSC) will guarantee there are two frames difference between active display frame and active storing field. Because the monitoring process of the channel can go active at any time, FRSC is used to direct active channel dump image at the right place in a video frame while display process is fetching pixels two frames away. If the frame rate of the display pipe is higher than the incoming video pipe, frame repeating process is employed to make sure the two frame boundary is maintained.

The four stored frames served also served another feature for 3D de-interlacing. If 3D de-interlacing is employed then there will be five pixel read stream from the neighboring frame to determine the merging process. More detailed information is in next chapter.

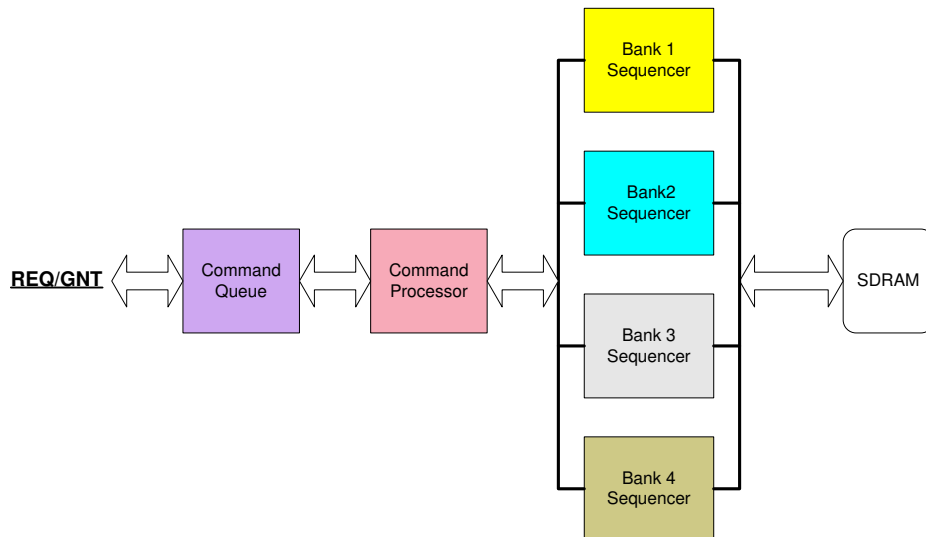

DCU Block Diagram

DCU Handshake

DCU consist of four major blocks: command queue, command processor, IO register and data collect state machine, bank sequencer. Command queue is the place stores all the pending DRAM transactions. Its buffer has an 8 level deep FIFO. The transaction protocol used with each functional unit is the dbus. dbus is a synchronous bus based on simple request / grant relationship. The following diagram is a typical transaction (read or write).

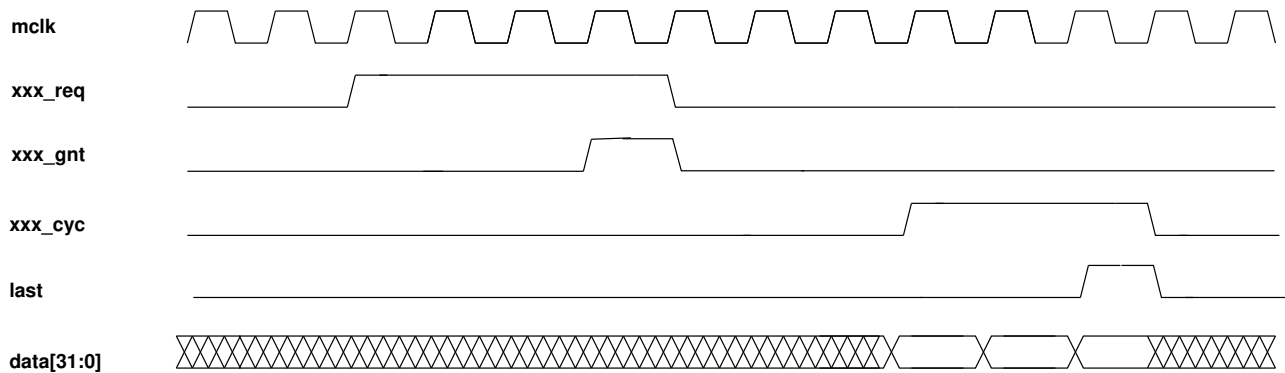

For requesting a DRAM transaction service, functional unit first write burst length, starting address, read/write information into its SDRAM information bus and raise its request line to DCU. Upon receiving the request, DCU will have the data collect state machine analyze the data and put them into request FIFO. Multiple requests are supported as long as there is no pending request of others. After this action is finished, a grant signal will be sent to the functional unit to acknowledge the receipt of the request. In normal circumstances, DCU should send out grant signal to functional units very quickly unless there is some long transaction going on. To finish the cycle, the functional unit should prepare its data access FIFO and wait for its xxx_cycle line to go high. Exchange of data (read or write) will continue as long as the cycle line is high and using the system clock as a counter. Read data bus is shared and write data bus is multiplexed using cycle arbiter. The last cycle flag is sent out in the last data phase.

If several DRAM requests are received simultaneously, an arbiter will arbitrate the incoming requests on a first-come-first-served basis and round-robin scheme is used for arbitration to ensure equal share of bandwidth to each unit. This means successive DRAM requests will get masked if other clients have requests. The masking will automatically disappear once other request is served.

It also supports several DRAM parameters including t_{RAS} , t_{RCD} for different DRAM vendors.

TW2880 DRAM Configuration Options

In forming the TW2880's DRAM subsystem, users have many options as TW2880 supports SDRAM density from 64Mbit, 128 Mbit to 256 Mbit. Normally we recommend our customers using 64 bit memory bus to get the most features but TW2880 also support 32 bit memory bus as well to save cost. The speed grade of the SDRAM chip is also very important as it affects how high the memory clock can go and thus it affects the memory bandwidth. Because the TW2880's memory PLL can generate many values so in the following tables I am only using 133 MHz, 147 MHz and 166 MHz as examples. The user should use these tables as a guide and figure out the features and options for a particular kind of memory.

Because memory vendors provide many selections in choosing memory like densities, data width and speed grade, customer can build their memory sub-system based on their needs.

DISPLAY PATH, 64 BIT, 256 MBIT, 8MX32X2 (SUGGESTED)

	133 MHz	147 MHz	166 MHz
1080p	Supported	Supported	Supported
2D / 3D	Supported	Supported	Supported
OSG	Not supported	Limited functions	Supported
Dual display	Not supported	Supported	Supported

DISPLAY PATH, 64 BIT, 128 MBIT, 4MX32X2 (SUGGESTED)

	133 MHz	147 MHz	166 MHz
1080p	Supported	Supported	Supported
2D / 3D	Supported	Supported	Supported
OSG	Not supported	Limited functions	Supported
Dual display	Not supported	Limited functions	Supported

DISPLAY PATH, 64 BIT, 64 MBIT, 2MX32X2

	133 MHz	147 MHz	166 MHz
1080p	Not supported	Not supported	Not supported
2D / 3D	2D	Supported	Supported
OSG	Not supported	Limited functions	Limited functions
Dual display	Not supported	Limited functions	Limited functions

DISPLAY PATH, 32 BIT, 128 MBIT, 4MX32X1

	133 MHz	147 MHz	166 MHz
1080p	Limited functions	Supported	Supported
2D / 3D	Not supported	Only 2D	Only 2D
OSG	Not supported	Limited functions	Limited functions
Dual display	Not supported	Not supported	Supported

DISPLAY PATH, 32 BIT, 64 MBIT, 2MX32X1 (NOT RECOMMENDED)

	133 MHz	147 MHz	166 MHz
1080p	Limited functions	Limited functions	Limited functions
2D / 3D	Only 2D	Only 2D	Only 2D
OSG	Not supported	Not supported	Not supported
Dual display	Not supported	Not supported	Not supported

RECORDING PATH, 64 BIT, 256 MBIT, 8MX32X2 (SUGGESTED)

	133 MHz	147 MHz	166 MHz
D1 FMI num#	16 channel	16 real time	16 real time
SPOT	Not supported	Not supported	1
Network port	Not supported	Not supported	Supported
4D1 / 6VGA	Not supported	Limited functions	Supported

RECORDING PATH, 64 BIT, 128 MBIT, 4MX32X2

	133 MHz	147 MHz	166 MHz
D1 FMI num#	16 channel (field)	16 real time (field)	16 real time (field)
SPOT	Not supported	Not supported	1
Network port	Not supported	Not supported	Supported
4D1 / 6VGA	Not supported	Limited functions	Supported

RECORDING PATH, 64 BIT, 64 MBIT, 2MX32X2

	133 MHz	147 MHz	166 MHz
D1 FMI num#	8 channel (field)	8 real time (field)	8 real time (field)
SPOT	Not supported	Not supported	1
Network port	Not supported	Not supported	Supported
4D1 / 6VGA	Not supported	Limited functions	Supported

RECORDING PATH, 32 BIT, 256 MBIT, 8MX32X1

	133 MHz	147 MHz	166 MHz
D1 FMI num#	Not supported	Not supported	Not supported
SPOT	Not supported	Not supported	Not supported
Network port	Not supported	Not supported	Not supported
4D1 / 6VGA	Not supported	Not supported	Not supported

RECORDING PATH, 32 BIT, 128 MBIT, 4MX32X1

	133 MHz	147 MHz	166 MHz
D1 FMI num#	8 channel (field)	8 real time (field)	8 real time (field)
SPOT	Not supported	1	1
Network port	Not supported	Not supported	Not supported
4D1 / 6VGA	Not supported	Not supported	Limited functions

RECORDING PATH, 32 BIT, 64 MBIT, 2MX32X1

	133 MHz	147 MHz	166 MHz
D1 FMI num#	4 channel (field)	4 real time (field)	4 real time (field)
SPOT	Not supported	Not supported	1
Network port	Not supported	Not supported	Not supported
4D1 / 6VGA	Not supported	Not supported	Limited functions

TW2880 DRAM Parameter Adjustments

The DRAM controller in TW2880 is designed to support different speed grades of DRAM from different manufacturers. Normally we suggest user use higher speed grade of DRAM because it will generate more bandwidth for the entire system. The SDRAM devices can be used in TW2880 based system are: -5 (200 MHz), -6 (166 MHz), -7 (142 MHz) and -7.5 (133 MHz). TW2880 always use CL-3 setting and do not use DQM or CS. So these signals can be static in the schematics. To determine whether a certain DRAM speed grade is suitable for a particular TW2880 system, we need to pay attention to t_{RAS} , t_{RCD} , t_{RC} , t_{WR} , t_{RP} , t_{WS} and t_{WH} for different DRAM vendors.

PARAMETERS	EXPLANATION	
t_{RAS}	RAS to pre-charge time	6T, 7T, 8T
t_{RCD}	RAS to CAS time	3T, 4T
t_{RC}	Access cycle time	9T, 10T, 11T
t_{WR}	Write turnaround time	2T
t_{RP}	Bank address pre-charge time	3T, 4T
t_{DS}	Data setup time, same as address	1 ns
t_{DH}	Data hold time, same as address	1 ns

Single Write

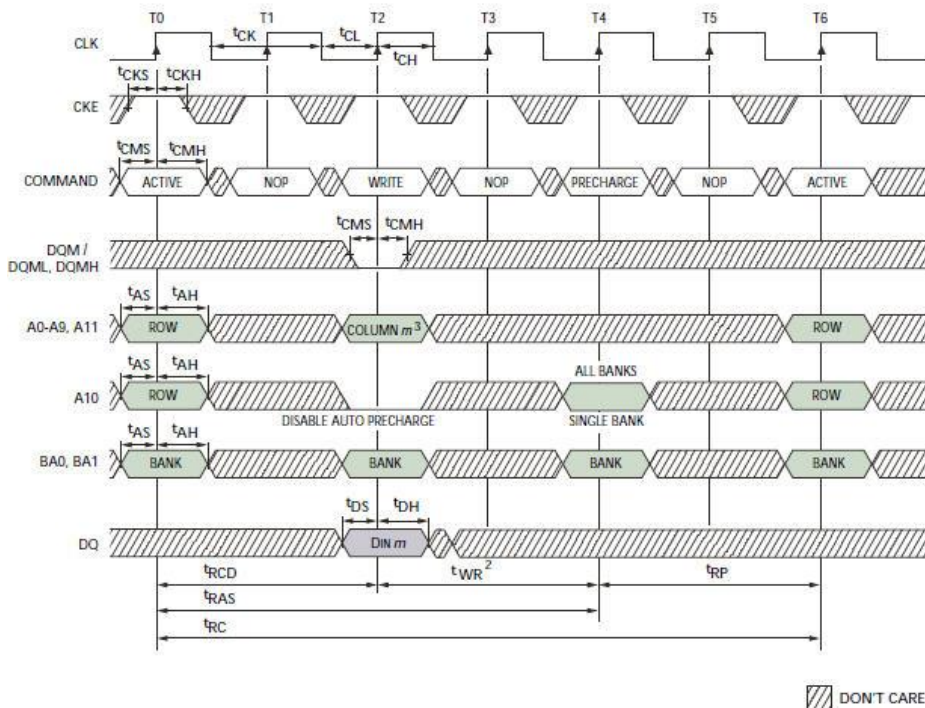

COMMAND AND ADDRESS TIMING

The transaction illustrated above is a single write operation. The basic definitions of each parameter can be found in the SDRAM data sheet. I choose the values from a typical manufacturer. Other manufacturer's value can also be used in this calculation. TW2880 has a fixed timing for each operation. t_{RAS} is 6T (clock period) minimum, t_{RCD} is 3T minimum, t_{RC} is 9T minimum, t_{WR} is 2T and t_{RP} is 3T. However if you set DRAM control register 0x211, 0x212

bit 3 to 0, you will get one more T for t_{RAS} , t_{RCD} and t_{RC} . Setting DRAM control register 0x211, 0x212 bit 6 to 1, you will get another T for t_{RP} and t_{RC} . The table below also shows the time delta variations in each clock setting.

Based on this we can calculate the five important constants in the DRAM operations:

Name	-7.5	-7	-6	-5	133-n	133-e	142-n	142-e	162-n	162-e
t_{RAS}	45	42	42	40	45	52.5	42	49	37.02	43.19
t_{RCD}	20	18	18	15	22.5	30	21	28	18.51	24.68
t_{RC}	65	60	60	55	67.5	75	63	70	55.53	61.7
t_{WR}	2T	2T	2T	2T	2T		2T		2T	
t_{RP}	20	18	18	15	22.5		21		18.51	

After this calculation user can make sure the device they choose are suitable running at certain frequencies. For example, a system run at 142 MHz can choose -7, -6 or -5 device.

SDRAM transaction always starts with sending command and later on address to the devices no matter it is a read or writes operation. For write operation it will followed by the data phase which has the same setup / hold requirements as the address. Page operation will make the timing parameters unimportant except t_{RCD} . Read operation is very similar to the write operation in command and address phase. However, the data phase is quite different and is discussed in the next section.

Single READ - Without Auto Precharge

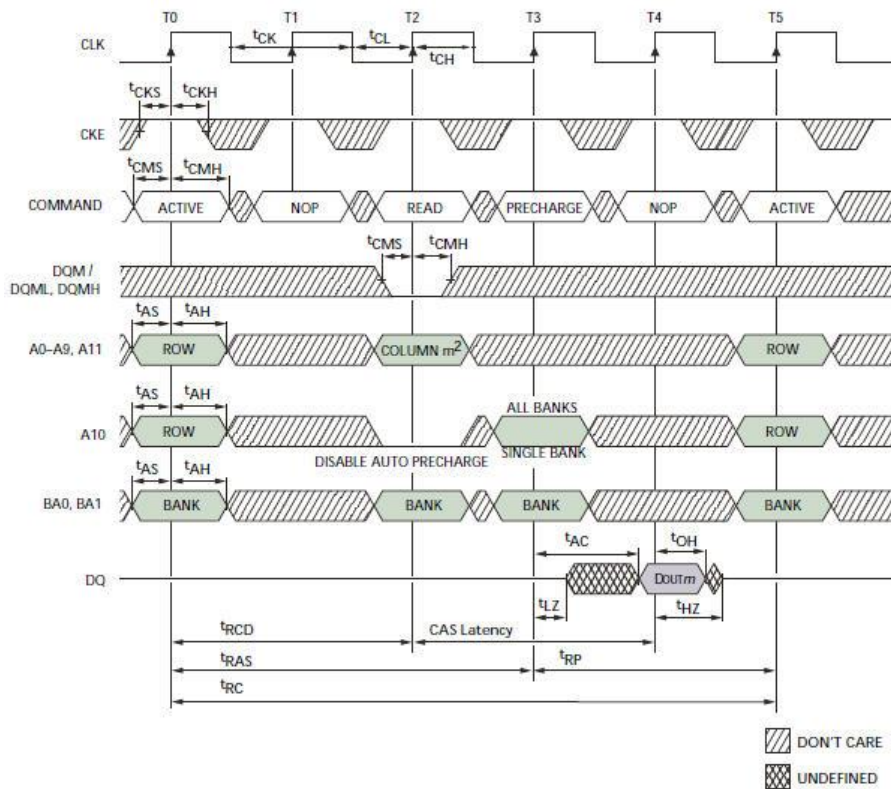

DATA READ / WRITE TIMING

The above discussion is for the command and address phase operations. In TW2880, we actually squeeze the timing on this side to help speed up the read operation. The concept is illustrated in the below diagram.

dram_mclk is actual clock used by the output DRAM device. d_mclk is a variation of the memory clock derived from inside. The timing relationship is controlled by register 0x220 bit 5:4 (display) and bit 7:6 (record). To get optimal read / write operations, we usually let dram_clock's edge a little ahead than the inside memory clock. Any command or address will be sent from the internal register clocked at mclk, travel through I/O pad and PCB traces and arrive at DRAM device but latched by slightly ahead dram_clk. As a result of this setting, the actual write propagation time is squeezed a little because we did not use the whole cycle. This is the case because we want to extend the read cycle timing as illustrated in the next drawing.

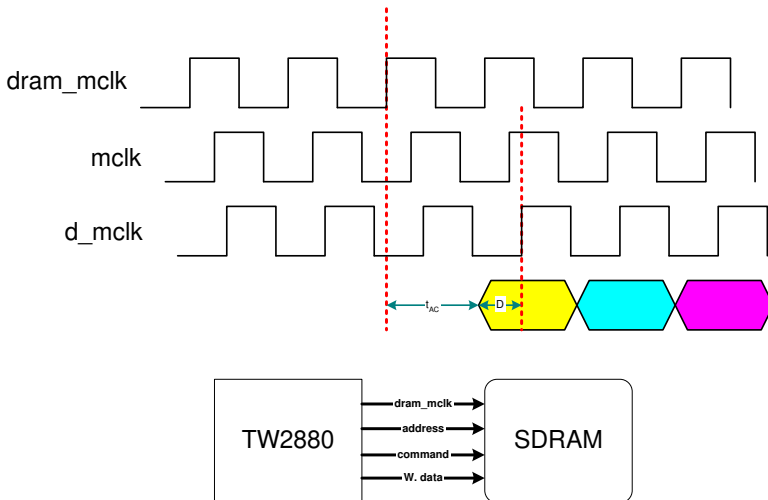
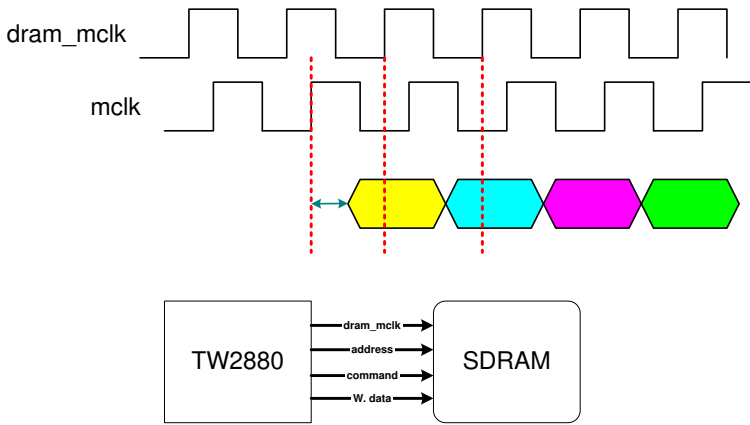

The following discussion is based on the diagram above. In this case, TW2880 is trying to do a read operation. The command phase and the address phase is the same as the write operation. In terms of read data travel path, data is clocked by dram_clock and after data access time t_{AC} will appear in the device's pad and after some delay in PCB traces and TW2880's I/O pad, data will be to the DCU's read latch and get latched by a delayed version of memory clock to buy more time. By using this technique, we can extend the read clock to the maximum.

The delay of d_mclk is adjustable by setting register 0x220 bit 5:4 (display) and bit 7:6 (record). The counting logic is controlled by the VCO clock in PLL, so if selecting divided by four option when you make the clock you will have four

selections, 8 selections will choosing divided by 8 option. So together with the `dram_mclk` option we will have at least 16 steps for adjusting t_{DS} , t_{DH} in the data side.

REFRESH OPTIONS

Refresh in TW2880 is controlled by register 0x211, 0x212 bit 5 and bit 4. Because read is the best form of refresh, user can set bit 5 to 1 to disable the refresh operation to save some band width. However, this is not possible if off screen memory is used. Bit 4 is used to choose 4K or 8K refresh option normally found in the DRAM manufacturers.

Frame Rate Control Unit

Introduction

Frame rate control module controls the relationship between read bank pointer for the display processor and the write bank pointer for the 20 input channels. Since the display frequency and the channel buffer write frequency is quite different, we need to make some adjustments to the pointers such that read and write operations do not happen in the same DRAM bank.

Generally speaking, if the reading operation is faster than writing operation, TW2880 will repeat the read bank image from time to time to avoid video tearing. On the other hand, if writing operation is faster than reading operation, TW2880 will skip frame by forcing the two frames get written into same bank. That means one underplayed video frame will be overwritten and not display. This mechanism is used in Weave de-interlacing method.

When 3D de-interlacing method is chosen, the four banks of memory will be treated as 8 fields. Five fields are needed at the same time to generate one field. TW2880 will rotate the banks and keep track of incoming fields and not to overwrite will the existing fields at the same time. Because the extra bandwidth requirements for the 3D de-interlacing, user has make sure the resolution and DRAM clock combination in order to get a display free from artifact. TW2880 also has 2D de-interlacing engine available, it only need one extra read at the same time. Overall, Weave de-interlacing method will be the bandwidth conscious method to display a progressive image.

SDRAM Allocation

In TW2880, fields are saved in banks. Field 0 and field 1 are saved in bank 0, field 2 and 3 are saved in bank 1, field 4 and 5 are saved in bank 2, and field 6 and field 7 are saved in bank 3. And then wrap around.

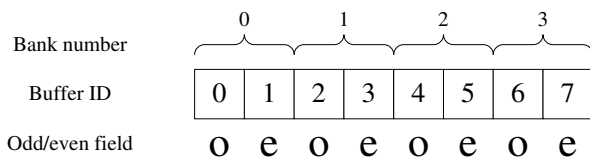

Bank number is from 0 to 3. Buffer ID number is from 0 to 7.

Read Buffer ID Calculation

There are three read out method: 3D de-interlacing, 2D de-interlacing, and the Weave de-interlacing method. If 3D de-interlacing is enabled, 5 pixels of data from 5 adjacent fields are needed to generate one pixel. For example, if buffer 0 is current display field, buffer 4, 5, 6 and 7 are needed to be read out at the same time. At this time only buffer 1 and 2 and 3 can be updated by write units. If 2D de-interlacing is enabled, only one field is needed to be read out. In this case, read out buffer ID is same as 3D de-interlacing.

Read out buffer ID is updated at the end of display frame. To be able to advance to the next read bank all the next read buffer IDs should not collide with their current write bank IDs. If not the read ID will stay the same for the new frame so old frame data is sent out repeated to the outside again. A frame repeating signal is available to indicate this action.

If Weave de-interlacing method is used, two fields in one bank are needed to be read out. In this case, bank number is current bank minus 1.

$$\text{bank_sel} = \text{rd_buf_id} / 2 - 1;$$

If we use $\text{rd_buf_id} / 2$, read out field may be conflict with write field. For example, if rd_buffer_id is 0, then buffer 0 and 1 will be read out. But buffer 1 may be written at the same time.

Write Buffer ID Calculation

For write, if frequency is fast, the previous frame will be overwritten. For example, if current write frame is in bank 0, that means odd field is written to buffer 0, even field is written to buffer 1. If next written bank is still bank 0, then next odd field is still written to buffer 0 and even field is still written to buffer 1. Write buffer is determined by write bank and field information. Write bank is always not less than previous one. But write buffer ID can be less than 1 then previous one. Write page number is output from frame rate control module.

There are totally 20 live video write units in TW2880. Because the incoming timing for each channel is totally asynchronous, we need to consider all the possible timing combinations. The following diagram shows four different write timing. In here, low level represents odd field and high level means even field. The number in the sequence means buffer ID.

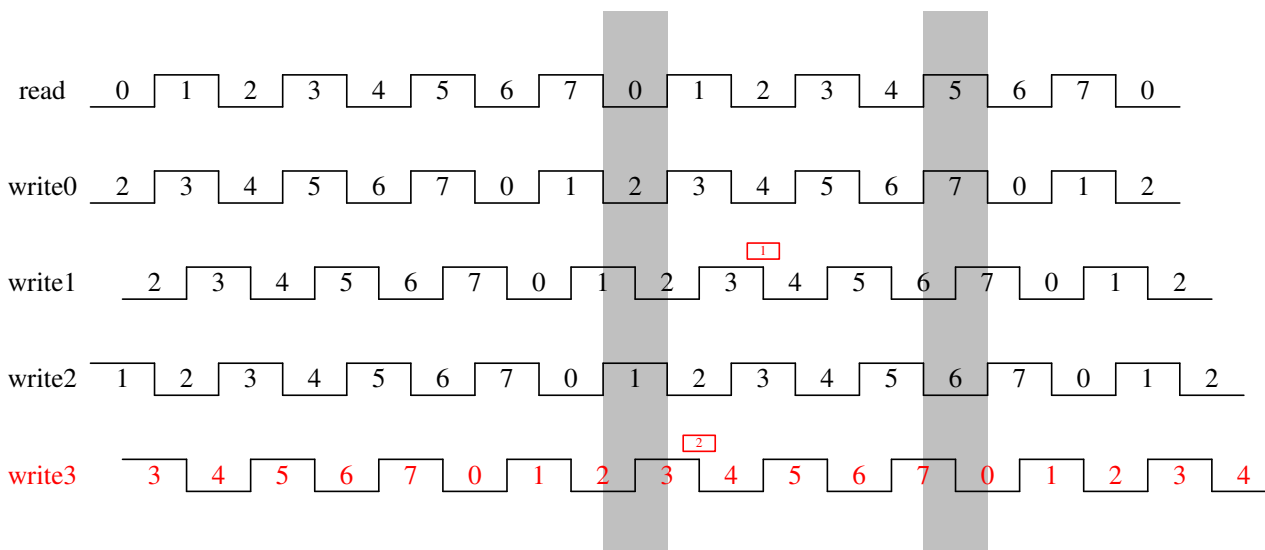

In this diagram, when read buffer ID equals to 0, write buffer ID could be 1 and 2 and 3. When read buffer ID is 5, write buffer could be 6 and 7 and 0. Write buffer will always get update in the beginning of odd field. So when we reading one buffer, there are altogether three buffers are being updated by write units.

From this timing diagram, we can find next write page is current read buffer plus 3 then divided by 2. Use write1 as first example, in position 1, write page need to be updated. Current read buffer ID is 2 and then next write buffer ID is $2+3=5$. Buffer ID 5 is in bank 2, so next write page is 2. That channel will write buffer 4 and 5. Use write2 as second example, in position 2, write page need to be updated. Current read buffer ID is 1, then next write buffer ID is $1+3=4$. Buffer ID 4 is in bank 2 so next write page is 2. That channel will write buffer 4 and 5.

In conclusion, we can use the following formulas:

$$\text{wr_buf_id_next} = \text{rd_buf_id} + 3$$

$$\text{wr_page} = \text{wr_buf_id_next} / 2.$$

If write operation is faster, that means read operation is slower so read buffer ID will keep same. From the last section we know the suggested write page number will be the same.

VGA Controller and Video interface

Introduction

TW2880 has glue-less video output interface capable of driving VGA-compatible display devices with screen size up to 1920x1080 at 60 Hz. As shown in the next diagram, display data is pulled from the SDRAM and sent to the VGA device through three 10 bit DACs according to the VGA timing. The display path used here is just an example, the detailed explanation of the display plane is in the next section.

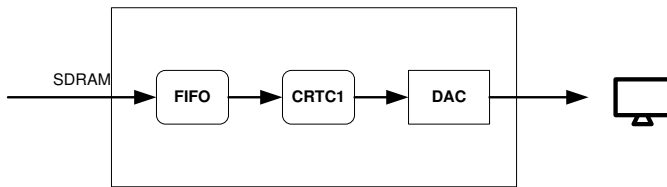

TW2880 Display Controller

Display controller includes Frame buffer controller, CRT controller and DAC for the progressive data stream. Based on the display requirements, Data FIFO will raise request through DBUS and get display data in advance. When the display is active, the data will be sent to display device and a series of requests will go into DCU. The FIFOs are designed to fetch display data based on the display pattern.

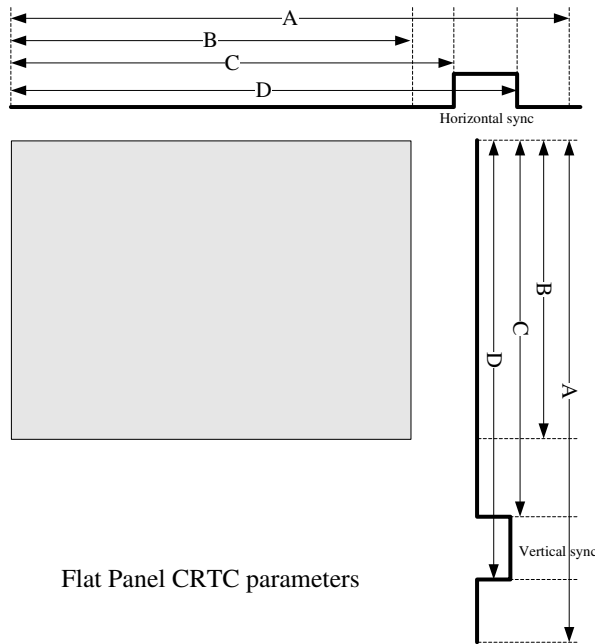

Flat Panel CRTC parameters

The frame display size is determined by horizontal total register (unit in pixel clock) and vertical total register (unit in scan line). Display end register is used to determine whether they are in active display area and if not data stream request to the FIFO can be turned off. Synchronization pulses are used to generate frame pulse and line pulse to the panel. The sync pulse start time and end time can adjust to fit different panels.

Features

- Support LCD monitor and HDMI TV
- Support interlaced mode and progressive mode for HDMI TV
- Resolution up to 1080p
- Support 2D/3D de-interlace
- Support upscale for video
- Support edge enhancement
- Support 16 live channel and 16 play back channel windows
- Support 4 Privacy windows / per channel
- Support simple OSD for 32 channels
- Support 16 motion box
- Support 8 single box
- Support 3 layer OSG, each layer has 8 sub-window
- Support upscale for OSG
- Support 2 layer mouse cursors
- Support up to 16 mouse shapes in SDRAM
- Support digital RGB gain
- Support CVBS output using dual monitor's TV encoder

Frame Buffer Controller

Frame buffer controller is the display data agent responsible for raising the request to the DCU and getting the display data and put into the FIFO. The frame buffer is a virtual buffer as it is actually a piece of DRAM address space and the fetch locations are controlled by the display buffer starting address. For progressive device the address counter will get reset when vertical end is reached. A reset in display buffer address occurs when a sequence of odd / even fields reach the vertical ends. At the end of the horizontal line CPU need to pad zero if the data is not aligned to the DWORD boundary. Line end is from horizontal display end.

Output Interface

TW2880 supports three display output interface formats on three different ports. These ports can be turned on and off independently. The main output port supports standard VGA socket (HD15) or the HDMI format from XGA to Full HD resolutions. And HDMI can also support interlaced video format such as 1080i. As the DVI-D port is compatible with HDMI port, user can choose to layout a DVI head in the board to support digital RGB LCD monitors.

Another output is the 24 bit RGB output port and the pins are shared with live video inputs. To use this output, incoming video decoder has to run at 108 MHz mode and user needs to turn on live video pin function control. The DualView port will be covered in next section and is not mentioned here anymore.

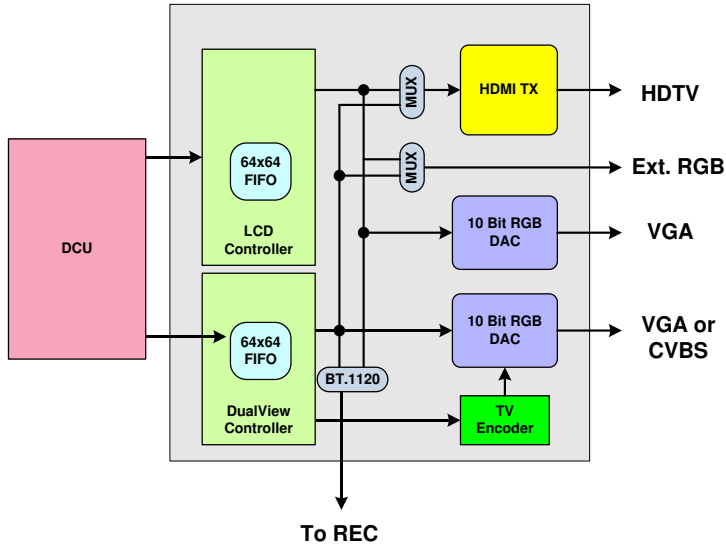

VGA Interface

The diagram on the right shows a VGA pin out. TW2880 uses R, G, B, Hsync and Vsync to drive video. Pin 10, 12, and 15 is used to support VESA E-DDC.

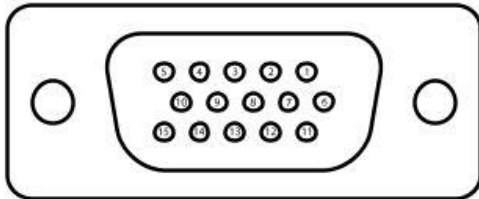

A female DE15 socket (video card side).

Pin 1	RED	Red video
Pin 2	GREEN	Green video
Pin 3	BLUE	Blue video
Pin 4	N/C	Not connected
Pin 5	GND	Ground (Hsync)
Pin 6	RED_RTN	Red return
Pin 7	GREEN_RTN	Green return
Pin 8	BLUE_RTN	Blue return
Pin 9	SENSE	+5 V DC from gfx adapter
Pin 10	GND	Ground (VSync, DDC)
Pin 11	N/C	Monitor ID
Pin 12	SDA	I ² C data
Pin 13	HSync	Horizontal sync
Pin 14	VSync	Vertical sync
Pin 15	SCL	I ² C clock

Block Diagram

There are ten display planes in the TW2880 display subsystem. There are, from the highest precedence to lowest: mouse, text cursor, OSG, single box, MD box, external OSD, simple OSD, live display, boundary and background. We have detailed description of each plane in the subsequent sections. The live display windows and background are compared and displayed on a pixel by pixel basis.

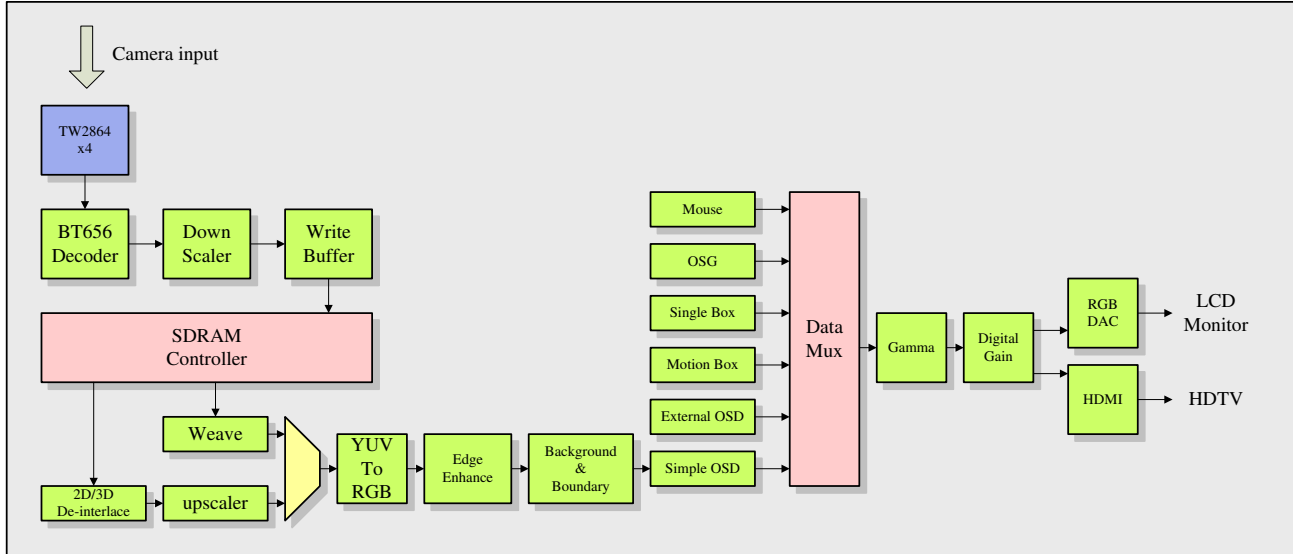

Display Layers

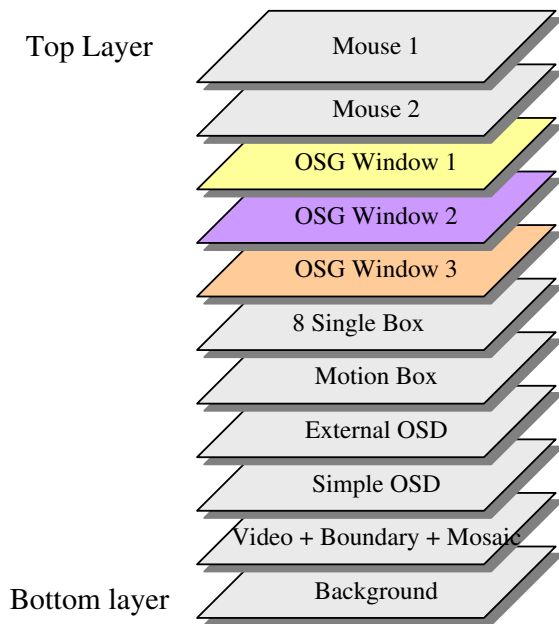

Display Resolutions

RESOLUTION	VCLK	HTT	HDE	HS	HSPW	HPOL	VTT	VDE	VS	VSPW	VSPOL
1280x1024	108	1688	1280	48	112	1	1066	1024	1	3	1
1440x900	106.5	1904	1440	80	152	0	934	900	3	6	1
1680x1050r	119	1840	1680	48	32	1	1080	1050	3	6	0
1920x1080p	148.5	2200	1920	88	44	1	1125	1080	4	5	0
1920x1080r	138.5	2080	1920	48	32	1	1111	1080	3	5	0
1920x1080	173	2576	1920	128	200	0	1120	1080	3	5	1
1920x1080i	74.25	2200	1920	88	44	1	562	540	2	5	0
1280x720	74.25	1650	1280	110	40	1	750	720	5	5	1
NTSC (480i)	13.5	858	720	16	64	1	262	240	3	4	0
PAL (576i)	13.5	864	720	16	64	1	312	288	3	4	0

This table is based on VESA standard. Some registers need to minus 1 such as HTT, HDE, VTT and VDE. 1920x1080p and 1920x1080i are based on EIA/CEA-861-B standard. "r" means reduced blank.

De-interlacing

TW2880 is equipped with advanced motion adaptive de-Interlacing circuit. If multi-channel display is desired, set the de-interlacing mode to MD or by-pass to use original Weave method. If one or two particular channels zoom up view are needed, user can only turn on few channels and pipe the data through scale up circuit to get the blow up view. The biggest size of the incoming video stream is limited to 1920 pixels. There are three de-interlacing method: Weave, 2D or 3D. In weave mode, no upscale supported.

Upscale

Up scaling function is only supported in 2D or 3D de-Interlaced mode is selected. TW2880's upscaler does not support channel based upscaling activities. That means all channels must be upscaled at the same time with the same ratio. When upscaling function is enabled, original channel position, size and boundaries will be changed. User must set POS_UPS_EN and POS_HSCALE and POS_VSCALE register accordingly to prevent wrong image.

Mouse Interface

TW2880 supports two identical 32x32 mouse pointer. One will be used as text cursor and the other will be used as mouse pointer. The location of the mouse0 is controlled by MOUSE0_HPOS and MOUSE0_VPOS register. User can write mouse data to local SRAM directly. Or user can write up to 16 mouse shape to SDRAM and then hardware load mouse shape to local SRAM automatically. Each mouse pixel has 4 bits.

Bit	Description
3	Blinking Control 1: Blink 0: Static
2	Mixing Control 1: Based on mouse mix control 0: mouse color
1:0	Mouse Type 00: Transparent 01: Filled with white color 10: Foreground color 11: Background color

To load mouse data to SRAM, there are total 1024 bytes in local SRAM. One mouse uses 512 bytes. Sample code is shown below:

```

for (i=0;i<1024;i=i+4)
begin
  PWRITE(12'h54c, i/4); //mouse data location
  PWRITE(12'h54d, mouse_data[i]); //mouse data
  PWRITE(12'h54d, mouse_data[i+1]); //mouse data
  PWRITE(12'h54d, mouse_data[i+2]); //mouse data
  PWRITE(12'h54d, mouse_data[i+3]); //mouse data
  PWRITE(12'h54f, 8'h00); //mouse data write enable
End

```

Mouse_data is 8 bit which is combined by two pixels. Bit[7:4] is p1, bit[3:0] is p0. Here is the SRAM allocation:

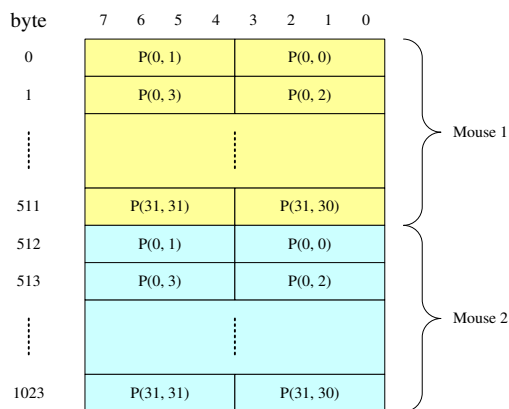

To load mouse shape to SDRM, sample code is shown below:

```

MOUSE_BASE_ADDR = 24'h3ffc00;
PWRITE(12'h46c, MOUSE_BASE_ADDR[7:0]); //MOUSE_BASE_ADDR[7:0]
PWRITE(12'h46d, MOUSE_BASE_ADDR[15:8]); //MOUSE_BASE_ADDR[15:8]
PWRITE(12'h46e, MOUSE_BASE_ADDR[23:16]); //MOUSE_BASE_ADDR[23:16]

host_dram_addr = MOUSE_BASE_ADDR;
PWRITE(12'h003, 8'he0); //dram_rw_ctrl, [7]:0:r, 1:w, [6]: enable, [5:0] b1

for(j=0;j<16;j=j+1)
begin
PWRITE(12'h000, host_dram_addr[7:0]); //dram_addr_l
PWRITE(12'h001, host_dram_addr[15:8]); //dram_addr_m
PWRITE(12'h002, host_dram_addr[23:16]); //dram_addr_h

for (i=0;i<256;i=i+1) PWRITE(12'h004, mouse_data[i]); //dram_data
PREAD(12'h044); //check status, if bit 0 is high, done

host_dram_addr = host_dram_addr + 8'h20;

PWRITE(12'h000, host_dram_addr[7:0]); //dram_addr_l
PWRITE(12'h001, host_dram_addr[15:8]); //dram_addr_m
PWRITE(12'h002, host_dram_addr[23:16]); //dram_addr_h

for (i=256;i<512;i=i+1) PWRITE(12'h004, mouse_data[i]); //dram_data
PREAD(12'h044); //check status, if bit 0 is high, done

host_dram_addr = host_dram_addr + 8'h20;
end

PWRITE(12'h470, 8'h00); //MOUSE_BUF,MOUSE_INDEX
PWRITE(12'h46f, 8'h01); //MOUSE_UPDATE_EN
PREAD(12'h46f); //check bit 0, if 0 done
    
```

Motion Box

TW2880 supports 16 motion box for live channels. Motion box positions and size can be set by registers. User must set these register according to live channels down scale ratio.

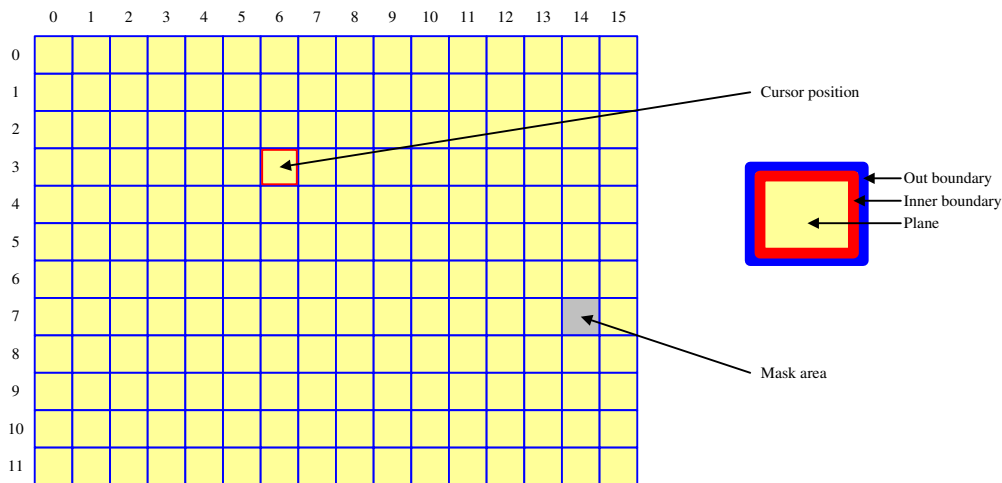

The user can enable plane, out boundary and inner boundary. Cursor and motion are using inner boundary. When motion detection mode is enabled, user must set horizontal cell number to 15 and vertical cell number to 12.

Single Box

TW2880 provides 8 single boxes which can be used for highlighting portion of the display. The effects include a single box or box cursor, a masking box and a box blending with a plane color. Each box has programmable location and sizes and controlled by BOX_HL (0x513 - 0x51A), BOX_HW (0x51B - 0x522), BOX_VT (0x523 - 0x52A) and BOX_VW (0x52B - 0x532) registers. The BOX_HL is the horizontal location of box with 2 pixel unit and the BOX_HW is the horizontal size of box with 2 pixel unit. The BOX_VT is the vertical location of box with 1 line unit and the BOX_VW is the vertical size of box with 1 line unit.

The display option is controlled by registers (0x50C - 0x510). BOX_PLNEN bit in these register enables each plane color and its R, G, B components are defined by registers 0x536, 0x537, 0x538 for box 1-4, by registers 0x496, 0x497, 0x498 for box 5-8. The color of box boundary is enabled via the BOX_BNDEN bit in the control registers and its color is defined by registers 0x533, 0x534, 0x535 for box 1-4, 0x493, 0x494, 0x495 for box 5-8.

In case that several boxes have same region specified, there will be a conflict of what to display for that region. Generally the TW2880 defines that box 0 has priority over box 7. So if a conflict happens between more than 2 boxes, box 0 will be displayed first as top layer and box 1 to box 7 are hidden beneath that are not supported for pop-up attribute unlike channel display.

Peak Function

TW2880B support peak function. This function make video looks sharp. It applies both horizontal and vertical directions.

OSG Layer

TW2880B main display support 3 layers OSG window. Each window has 8 sub-windows. But 8 sub-window cannot overlap. Each sub-window has its own memory location and screen location and size. Detail descriptions are in OSG chapter.

Simple OSD

TW2880B support 32 channel simple OSD. Simple OSD is font based OSD. In each channel, it can support 8 font channel number information and 32x32 pictures. In whole screen, it support 32 title and 32 time information. Detail descriptions are in OSD chapter.

Background and Channel Boundary

The area without video will show background. Background color is 24bit color which can be set by registers.

Each channel has its own boundary. TW2880B can support 32 channel boundary. Channel position and size information are got from rgb_interface related registers. If upscale is enable, user must turn on pos_ups_en and set correct pos_hscale and pos_vscale registers. In some cases, video is not turn on, user still wanted to show boundary for this channel. User must set the following registers:

```
[0x4F0] to [0x4F3]: BND_CH_EN  
[0x4CE] bit 4: BND_CH_EN_SEL, this bit must be set to "1"  
[0x4F8] to [0x4FA]: NOVID_R/G/B
```

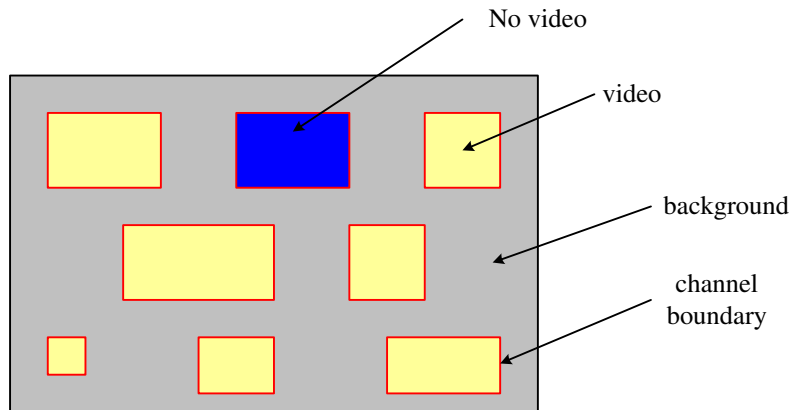

Display Background and Boundary

Digital Gain

Digital gain is the last stage of the video pipe and is operated on the RGB color space. The formulary is:

$$R = R * R_GAIN + R_OFFSET$$

$$G = G * G_GAIN + G_OFFSET$$

$$B = B * B_GAIN + B_OFFSET$$

Gain and offset are set by register. 0x40 is default value which gain is "1". Offset is 2's complement value. "0" means no offset. 0x7f is maximum offset. 0x80 is -128 and 0xFF is -1.

Register Table

Following are pages 4 and 5. Page 1 for OSG and simple OSD is described in a separate section.

Address	R/W	Default	Description
0x400	R/W	0x10	[7:4]: rg_afm_ctl [2]: rg_di_use_bob [1]: rg_di_use_3field [0]: rg_force_2ddi
0x401	R/W	0x00	rg_di_err_base[7:0]
0x402	R/W	0x00	rg_di_err_base[15:8]
0x403	R/W	0x00	rg_di_err_base[21:16]
0x404	R/W	0xF0	rg_man_wr_height[7:0]
0x405	R/W	0x00	rg_man_wr_height[10:8]
0x406	R/W	0xD0	rg_man_wr_width[7:0]
0x407	R/W	0x02	rg_man_wr_width[10:8]
0x408	R/W	0x00	rg_ditb0[6:0]
0x409	R/W	0x04	rg_ditb4[6:0]
0x40A	R/W	0x08	rg_ditb8
0x40B	R/W	0x0C	rg_ditb12
0x40C	R/W	0x40	rg_ditb16
0x40D	R/W	0x40	rg_ditb24
0x40E	R/W	0x40	rg_ditb32
0x40F	R/W	0x40	rg_ditb48
0x410	R/W	0x30	rg_afm_yf02_thd
0x411	R/W	0x68	rg_afm_yf02_h_thd
0x412	R/W	0x08	rg_afm_yf01_thd
0x413	R/W	0x80	rg_afm_yf01_h_thd
0x414	R/W	0x01	rg_32_caption_thd
0x415	R/W	0x00	[7:4]: rg_ups1_vsharp_gain [1]: rg_ups1_vlimit_on [0]: rg_disable_man_disp
0x416	R/W	0x00	rg_BGcolor
0x417	R/W	0x00	rg_ups1_hscale[7:0]
0x418	R/W	0x10	rg_ups1_hscale[12:8]
0x419	R/W	0x00	rg_ups1_vscale[7:0]
0x41A	R/W	0x04	rg_ups1_vscale[10:8]
0x41B	R/W	0x00	rg_ups1_Xst[7:0]
0x41C	R/W	0x00	rg_ups1_Xst[10:8]
0x41D	R/W	0x00	rg_ups1_Yst[7:0]
0x41E	R/W	0x00	rg_ups1_Yst[10:8]
0x41F	R/W	0xD0	rg_ups1_Xmax[7:0]
0x420	R/W	0x02	rg_ups1_Xmax[10:8]
0x421	R/W	0xE0	rg_ups1_Ymax[7:0]
0x422	R/W	0x01	rg_ups1_Ymax[10:8]
0x423	R/W	0x00	rg_ups1_Xoff
0x424	R/W	0x00	rg_ups1_Yoff
0x425	R/W	0x00	[7]: rg_panorama [6]: rg_ups1_hs_type [5:4]: rg_ups1_hs_step [3:0]: rg_ups1_hs_inc
0x426	R/W	0x00	rg_ups1_hs_center[7:0]
0x427	R/W	0x00	rg_ups1_hs_center[12:8]
0x428	R/W	0x00	rg_2ddi_ctl

Address	R/W	Default	Description
0x429	R/W	0x28	rg_2ddi_thd1
0x42A	R/W	0x1E	rg_2ddi_thd2
0x42B	R/W	0x28	rg_2ddi_thd3
0x42C	R/W	0x10	rg_2ddi_thd4
0x42D	R/W	0x24	rg_2ddi_thd5
0x42E	R/W	0x6F	rg_2ddi_thd6
0x42F	R/W	0x00	rg_3ddi_ctl
0x430	R/W	0x0A	rg_3ddi_thd1
0x431	R/W	0x95	rg_3ddi_thd2
0x432	R/W	0x00	rg_ups1_dbg
0x440	R/W	0x00	SBOX4_CTRL[4:0]
0x441	R/W	0x00	SBOX5_CTRL[4:0]
0x442	R/W	0x00	SBOX6_CTRL[4:0]
0x443	R/W	0x00	SBOX7_CTRL[4:0]
0x444	R/W	0x00	[7:6]: SBOX5_V_LINE [5:4]: SBOX5_H_LINE [3:2]: SBOX4_V_LINE [1:0]: SBOX4_H_LINE
0x445	R/W	0x00	[7:6]: SBOX5_V_LINE [5:4]: SBOX5_H_LINE [3:2]: SBOX4_V_LINE [1:0]: SBOX4_H_LINE
0x446	R/W	0x00	SBOX4_HL[7:0]
0x447	R/W	0x00	SBOX4_HL[10:8]
0x448	R/W	0x00	SBOX5_HL[7:0]
0x449	R/W	0x00	SBOX5_HL[10:8]
0x44A	R/W	0x00	SBOX6_HL[7:0]
0x44B	R/W	0x00	SBOX6_HL[10:8]
0x44C	R/W	0x00	SBOX7_HL[7:0]
0x44D	R/W	0x00	SBOX7_HL[10:8]
0x44E	R/W	0x00	SBOX4_HR[7:0]
0x44F	R/W	0x00	SBOX4_HR[10:8]
0x450	R/W	0x00	SBOX5_HR[7:0]
0x451	R/W	0x00	SBOX5_HR[10:8]
0x452	R/W	0x00	SBOX6_HR[7:0]
0x453	R/W	0x00	SBOX6_HR[10:8]
0x454	R/W	0x00	SBOX7_HR[7:0]
0x455	R/W	0x00	SBOX7_HR[10:8]
0x456	R/W	0x00	SBOX4_VT[7:0]
0x457	R/W	0x00	SBOX4_VT[10:8]
0x458	R/W	0x00	SBOX5_VT[7:0]
0x459	R/W	0x00	SBOX5_VT[10:8]
0x45A	R/W	0x00	SBOX6_VT[7:0]
0x45B	R/W	0x00	SBOX6_VT[10:8]
0x45C	R/W	0x00	SBOX7_VT[7:0]
0x45D	R/W	0x00	SBOX7_VT[10:8]
0x45E	R/W	0x00	SBOX4_VB[7:0]
0x45F	R/W	0x00	SBOX4_VB[10:8]
0x460	R/W	0x00	SBOX5_VB[7:0]
0x461	R/W	0x00	SBOX5_VB[10:8]
0x462	R/W	0x00	SBOX6_VB[7:0]
0x463	R/W	0x00	SBOX6_VB[10:8]

Address	R/W	Default	Description
0x464	R/W	0x00	SBOX7_VB[7:0]
0x465	R/W	0x00	SBOX7_VB[10:8]
0x466	R/W	0x00	BBR2: Box border R
0x467	R/W	0x00	BBG2: Box border G
0x468	R/W	0x00	BBB2: Box border B
0x469	R/W	0x00	BPR2: Box plane R
0x46A	R/W	0x00	BPG2: Box plane G
0x46B	R/W	0x00	BPB2: Box plane B
0x46C	R/W	0x00	MOUSE_BASE_ADDR[7:0]
0x46D	R/W	0x00	MOUSE_BASE_ADDR[15:8]
0x46E	R/W	0x00	MOUSE_BASE_ADDR[23:16]
0x46F	R/W	0x00	[0]: MOUSE_UPDATE_EN, MOUSE_UPDATE_BUSY
0x470	R/W	0x00	[4]: MOUSE_BUF [3:0]: MOUSE_INDEX
0x471			
0x472	R/W	0x00	VPOS_32[7:0]
0x473	R/W	0x00	HPOS_32[7:0]
0x474	R/W	0x00	VSIZE_32[7:0]
0x475	R/W	0x00	HSIZE_32[7:0]
0x476	RW	0x00	[5:4]:HPOS_32[9:8] [3:0]: VPOS_32[11:8]
0x477	R/W	0x00	[4]:HSIZE_32[8] [2:0]: VSIZE_32[10:8]
0x478	R/W	0x00	DM_VPOS_32[7:0]
0x479	R/W	0x00	DM_HPOS_32[7:0]
0x47A	R/W	0x00	DM_VSIZE_32[7:0]
0x47B	R/W	0x00	DM_HSIZE_32[7:0]
0x47C	RW	0x00	[5:4]: DM_HPOS_32[9:8] [3:0]: DM_VPOS_32[11:8]
0x47D	R/W	0x00	[4]: DM_HSIZE_32[8] [2:0]: DM_VSIZE_32[10:8]
0x47E	R/W	0x00	[1]: CH32_BND_EN [0]: CH32_EN
0x47F	R/W	0x00	[1]: DM_CH32_BND_EN [0]: DM_CH32_EN
0x480	R/W	0x80	[7]: OUT_DIS [6]: MDBOX_POS_SEL [5]: Reserved [4]: BND_EN [3]: COLBAR_EN [2]: SWITCH_EN [1]: HSPOL [0]: VSPOL
0x481	R/W	0x2F	[7:4]: BND_WIDTH [3:0]: VSDEL
0x482	R/W	0xFF	BND_R: Channel Boundary R
0x483	R/W	0xFF	BND_G: Channel Boundary G
0x484	R/W	0xFF	BND_B: Channel Boundary B
0x485	R/W	0x00	POS_HSCALE[7:0]
0x486	R/W	0x10	POS_HSCALE[15:8]
0x487	R/W	0x00	POS_VSCALE[7:0]
0x488	R/W	0x10	POS_VSCALE[15:8]
0x489	R/W	0x00	[0]: POS_UPS_EN

Address	R/W	Default	Description
0x48A	R/W	0x00	[1:0]: OSD_BLINK_TIME
0x48B	R/W	0x00	[7:4]: CUR1_VPOS [3:0]: CUR0_VPOS
0x48C	R/W	0x00	[7:4]: CUR3_VPOS [3:0]: CUR2_VPOS
0x48D	R/W	0x00	[7:4]: CUR5_VPOS [3:0]: CUR4_VPOS
0x48E	R/W	0x00	[7:4]: CUR7_VPOS [3:0]: CUR6_VPOS
0x48F	R/W	0x00	[7:4]: CUR9_VPOS [3:0]: CUR8_VPOS
0x490	R/W	0x00	[7:4]: CUR11_VPOS [3:0]: CUR10_VPOS
0x491	R/W	0x00	[7:4]: CUR13_VPOS [3:0]: CUR12_VPOS
0x492	R/W	0x00	[7:4]: CUR15_VPOS [3:0]: CUR14_VPOS
0x493	R/W	0x00	MDBOX_OBR
0x494	R/W	0x00	MDBOX_OBG
0x495	R/W	0x00	MDBOX_OBB
0x496	R/W	0x00	MDBOX_IBR
0x497	R/W	0x00	MDBOX_IBG
0x498	R/W	0x00	MDBOX_IBB
0x499	R/W	0x00	MDBOX_MSKR
0x49A	R/W	0x00	MDBOX_MSKG
0x49B	R/W	0x00	MDBOX_MSKB
0x49C	R/W	0x00	MDBOX_PR
0x49D	R/W	0x00	MDBOX_PG
0x49E	R/W	0x00	MDBOX_PB
0x49F			
0x4A0	R/W	0x00	HSTART[7:0]
0x4A1	R/W	0x00	HSTART[9:8]
0x4A2	R/W	0x00	VSTART[7:0]
0x4A3	R/W	0x00	VSTART[11:8]
0x4A4	R/W	0xFF	VTT_WIN
0x4A5	R/W	0x00	[2]: VTT_ADJUST [1]: VTT_ADJUST_MODE [0]: VTT_ADJUST_EN
0x4A6	RO	-	NEW_VTT_RGBW[7:0]
0x4A7	RO	-	NEW_VTT_RGBW[11:8]
0x4A8	RO	-	NEW_VTT[7:0]
0x4A9	RO	-	NEW_VTT[10:8]
0x4AA	R/W	0xFF	[7:4]: BND_EN_1 [3:0]: BND_EN_0
0x4AB	R/W	0xFF	[7:4]: BND_EN_3 [3:0]: BND_EN_2
0x4AC	R/W	0xFF	[7:4]: BND_EN_5 [3:0]: BND_EN_4
0x4AD	R/W	0xFF	[7:4]: BND_EN_7 [3:0]: BND_EN_6
0x4AE	R/W	0xFF	[7:4]: BND_EN_9 [3:0]: BND_EN_8

Address	R/W	Default	Description
0x4AF	R/W	0xFF	[7:4]: BND_EN_11 [3:0]: BND_EN_10
0x4B0	R/W	0xFF	[7:4]: BND_EN_13 [3:0]: BND_EN_12
0x4B1	R/W	0xFF	[7:4]: BND_EN_15 [3:0]: BND_EN_14
0x4B2	R/W	0xFF	[7:4]: BND_EN_17 [3:0]: BND_EN_16
0x4B3	R/W	0xFF	[7:4]: BND_EN_19 [3:0]: BND_EN_18
0x4B4	R/W	0xFF	PS2CON[7:0]
0x4B5	R/W	0xFF	PS2CON[15:8]
0x4B6	RO	-	PS2DATA_OUT[7:0]
0x4B7	RO	-	PS2DATA_OUT[15:8]
0x4B8	RO	-	PS2DATA_OUT[23:16]
0x4B9	RO	-	PS2DATA_OUT[31:24]
0x4BA	R/W		[0]: ps2_int_reg
0x4BB	R/W	0x00	[4]: EOSD_SEL [3]: EOSD_EN [2]: EOSD_MODE [1]: EOSD_EN_DIS [0]: EOSD_ALPHA_EN
0x4BC	R/W	0x00	[3:0]: EOSD_ALPHA
0x4BD	R/W	0x00	EOSD_R
0x4BE	R/W	0x00	EOSD_G
0x4BF	R/W	0x00	EOSD_B
0x4C0	R/W	0xFF	[3:0]: INT_MASK [3]: osg_vblank_int_mask [2]: ps2_int_mask [1]: osg_host_busy_int_mask [0]: osg_host_wait_int_mask
0x4C1	R/W	0x00	[3]: osg_vblank_int / clear [2]: ps2_int / clear [1]: osg_host_busy_int / clear [0]: osg_host_wait_int / clear
0x4C2	R/W	0x00	FRSC_DBG_CTRL [7]: rd_buf_id_toggle [6]: rd_buf_inc [5]: wr_page_fix [4]: rd_page_fix [3:2]: wr_page_sel [1:0]: rd_page_sel
0x4C3	R/W	0x60	[7:5]: WR_BUF_OFST [4]: INTERLACE_DBG [3]: VTT_INV [2]: EVEN_REPEAT [1]: DMON_VS_EN [0]: interlace
0x4C4	R/W	0xFF	[7:4]: BND_EN_21 [3:0]: BND_EN_20
0x4C5	R/W	0xFF	[7:4]: BND_EN_23 [3:0]: BND_EN_22
0x4C6	R/W	0xFF	[7:4]: BND_EN_25 [3:0]: BND_EN_24

Address	R/W	Default	Description
0x4C7	R/W	0xFF	[7:4]: BND_EN_27 [3:0]: BND_EN_26
0x4C8	R/W	0xFF	[7:4]: BND_EN_29 [3:0]: BND_EN_28
0x4C9	R/W	0xFF	[7:4]: BND_EN_31 [3:0]: BND_EN_30
0x4CA	R/W	0x00	GAMA_ADDR[7:0]
0x4CB	R/W	0x00	GAMA_ADDR[9:8]
0x4CC	R/W	0x00	GAMA_DATA[7:0]
0x4CD	R/W	0x00	GAMA_DATA[9:8]
0x4CE	R/W	0x00	[6]: OSD_CH_EN_SEL [5]: NOVID_SWITCH_EN [4]: BND_CH_EN_SEL [3]: PEAK_C_DUP [2]: GAIN_EN [1]: PEAK_EN [0]: GAMA_EN
0x4CF	R/W	0x00	FRSC_DBG_CTRL[15:8] [5:4]: rd_buf_id_sel_dm [3:2]: rd_buf_id_sel [1]: fld_inv [0]: all_available
0x4D0	R/W	0x30	[7:0]: PEAK_CTRL
0x4D1	R/W	0x00	PEAK_TB0
0x4D2	R/W	0x00	PEAK_TB1
0x4D3	R/W	0x00	PEAK_TB2
0x4D4	R/W	0x00	PEAK_TB3
0x4D5	R/W	0x00	PEAK_TB4
0x4D6	R/W	0x00	PEAK_TB5
0x4D7	R/W	0x00	PEAK_VTB
0x4D8	R/W	0x00	[7:4]: PEAK_FTHD [3:0]: PEAK_CORING
0x4D9	R/W	0x00	[4:0]: PEAK_OVERSHOT
0x4DA	R/W	0x40	R_GAIN
0x4DB	R/W	0x40	G_GAIN
0x4DC	R/W	0x40	B_GAIN
0x4DD	R/W	0	R_OFST
0x4DE	R/W	0	G_OFST
0x4DF	R/W	0	B_OFST
0x4F0	R/W	0	BND_CH_EN[7:0]
0x4F1	R/W	0	BND_CH_EN[15:8]
0x4F2	R/W	0	BND_CH_EN[23:16]
0x4F3	R/W	0	BND_CH_EN[31:24]
0x4F4	R/W	0xFF	FRSC_CH_EN[7:0]
0x4F5	R/W	0xFF	FRSC_CH_EN[15:8]
0x4F6	R/W	0xFF	FRSC_CH_EN[23:16]
0x4F7	R/W	0xFF	FRSC_CH_EN[31:24]
0x4F8	R/W	0	NOVID_R
0x4F9	R/W	0	NOVID_G
0x4FA	R/W	0xFF	NOVID_B
0x500	R/W	0x2F	HTT[7:0]
0x501	R/W	0x07	HTT[12:8]

Address	R/W	Default	Description
0x502	R/W	0x37	VTT[7:0]
0x503	R/W	0x04	VTT[10:8]
0x504	R/W	0x8F	HDE[7:0]
0x505	R/W	0x06	HDE[10:8]
0x506	R/W	0x19	VDE[7:0]
0x507	R/W	0x04	VDE[10:8]
0x508	R/W	0x30	PHSYNC[8:1]
0x509	R/W	0x02	PVSYNC[7:0]
0x50A	R/W	0x20	HSPW[7:0]
0x50B	R/W	0x06	VSPW[7:0]
0x50C	R/W	0x00	SBOX0_CTRL[4:0]
0x50D	R/W	0x00	SBOX1_CTRL[4:0]
0x50E	R/W	0x00	SBOX2_CTRL[4:0]
0x50F	R/W	0x00	SBOX3_CTRL[4:0]
0x511	R/W	0x00	[7:6]: SBOX3_V_LINE [5:4]: SBOX3_H_LINE [3:2]: SBOX2_V_LINE [1:0]: SBOX2_H_LINE
0x512	R/W	0x00	[7:6]: SBOX1_V_LINE [5:4]: SBOX1_H_LINE [3:2]: SBOX0_V_LINE [1:0]: SBOX0_H_LINE
0x513	R/W	0x00	SBOX0_HL[7:0]
0x514	R/W	0x00	SBOX0_HL[10:8]
0x515	R/W	0x00	SBOX1_HL[7:0]
0x516	R/W	0x00	SBOX1_HL[10:8]
0x517	R/W	0x00	SBOX2_HL[7:0]
0x518	R/W	0x00	SBOX2_HL[10:8]
0x519	R/W	0x00	SBOX3_HL[7:0]
0x51A	R/W	0x00	SBOX3_HL[10:8]
0x51B	R/W	0x00	SBOX0_HR[7:0]
0x51C	R/W	0x00	SBOX0_HR[10:8]
0x51D	R/W	0x00	SBOX1_HR[7:0]
0x51E	R/W	0x00	SBOX1_HR[10:8]
0x51F	R/W	0x00	SBOX2_HR[7:0]
0x520	R/W	0x00	SBOX2_HR[10:8]
0x521	R/W	0x00	SBOX3_HR[7:0]
0x522	R/W	0x00	SBOX3_HR[10:8]
0x523	R/W	0x00	SBOX0_VT[7:0]
0x524	R/W	0x00	SBOX0_VT[10:8]
0x525	R/W	0x00	SBOX1_VT[7:0]
0x526	R/W	0x00	SBOX1_VT[10:8]
0x527	R/W	0x00	SBOX2_VT[7:0]
0x528	R/W	0x00	SBOX2_VT[10:8]
0x529	R/W	0x00	SBOX3_VT[7:0]
0x52A	R/W	0x00	SBOX3_VT[10:8]
0x52B	R/W	0x00	SBOX0_VB[7:0]
0x52C	R/W	0x00	SBOX0_VB[10:8]
0x52D	R/W	0x00	SBOX1_VB[7:0]
0x52E	R/W	0x00	SBOX1_VB[10:8]
0x52F	R/W	0x00	SBOX2_VB[7:0]
0x530	R/W	0x00	SBOX2_VB[10:8]

Address	R/W	Default	Description
0x531	R/W	0x00	SBOX3_VB[7:0]
0x532	R/W	0x00	SBOX3_VB[10:8]
0x533	R/W	0x00	BBR: Box border R
0x534	R/W	0x00	BBG: Box border G
0x535	R/W	0x00	BBB: Box border B
0x536	R/W	0x00	BPR: Box plane R
0x537	R/W	0x00	BPG: Box plane G
0x538	R/W	0x00	BPB: Box plane B
0x539	R/W	0x00	BAR: Background R
0x53A	R/W	0x00	BAG: Background G
0x53B	R/W	0x00	BAB: Background B
0x53C	R/W	0x00	MOUSE0_HPOS[7:0]
0x53D	R/W	0x00	MOUSE0_HPOS[10:8]
0x53E	R/W	0x00	MOUSE0_VPOS[7:0]
0x53F	R/W	0x00	MOUSE0_VPOS[10:8]
0x540	R/W	0x00	MOUSE1_HPOS[7:0]
0x541	R/W	0x00	MOUSE1_HPOS[10:8]
0x542	R/W	0x00	MOUSE1_VPOS[7:0]
0x543	R/W	0x00	MOUSE1_VPOS[10:8]
0x544	R/W	0x00	[6:4]: MOUSE1_CTRL [2:0]: MOUSE0_CTRL
0x545	R/W	0x00	BR: mouse background R
0x546	R/W	0x00	BG: mouse background G
0x547	R/W	0x00	BB: mouse background B
0x548	R/W	0x00	FR: mouse foreground R
0x549	R/W	0x00	FG: mouse foreground G
0x54A	R/W	0x00	FB: mouse foreground B
0x54B	R/W	0x00	DMODE[1:0]
0x54C	R/W	0x00	MOUSE_WR_LOC[7:0]
0x54D	R/W	0x00	MOUSE_WR_DATA
0x54E	R/W	0x01	MOUSE_REG_UPDATE
0x54F	WO	0x00	MOUSE_WR_EN
0x550	R/W	0x00	MDBOX0_CTRL[7:0]
0x551	R/W	0x00	MDBOX1_CTRL[7:0]
0x552	R/W	0x00	MDBOX2_CTRL[7:0]
0x553	R/W	0x00	MDBOX3_CTRL[7:0]
0x554	R/W	0x00	MDBOX4_CTRL[7:0]
0x555	R/W	0x00	MDBOX5_CTRL[7:0]
0x556	R/W	0x00	MDBOX6_CTRL[7:0]
0x557	R/W	0x00	MDBOX7_CTRL[7:0]
0x558	R/W	0x00	MDBOX8_CTRL[7:0]
0x559	R/W	0x00	MDBOX9_CTRL[7:0]
0x55A	R/W	0x00	MDBOX10_CTRL[7:0]
0x55B	R/W	0x00	MDBOX11_CTRL[7:0]
0x55C	R/W	0x00	MDBOX12_CTRL[7:0]
0x55D	R/W	0x00	MDBOX13_CTRL[7:0]
0x55E	R/W	0x00	MDBOX14_CTRL[7:0]
0x55F	R/W	0x00	MDBOX15_CTRL[7:0]
0x560	R/W	0x00	[7:6]: MDBOX1_V_LINE [5:4]: MDBOX1_H_LINE [3:2]: MDBOX0_V_LINE [1:0]: MDBOX0_H_LINE

Address	R/W	Default	Description
0x561	R/W	0x00	[7:6]: MDBOX3_V_LINE [5:4]: MDBOX3_H_LINE [3:2]: MDBOX2_V_LINE [1:0]: MDBOX2_H_LINE
0x562	R/W	0x00	[7:6]: MDBOX5_V_LINE [5:4]: MDBOX5_H_LINE [3:2]: MDBOX4_V_LINE [1:0]: MDBOX4_H_LINE
0x563	R/W	0x00	[7:6]: MDBOX7_V_LINE [5:4]: MDBOX7_H_LINE [3:2]: MDBOX6_V_LINE [1:0]: MDBOX6_H_LINE
0x564	R/W	0x00	[7:6]: MDBOX9_V_LINE [5:4]: MDBOX9_H_LINE [3:2]: MDBOX8_V_LINE [1:0]: MDBOX8_H_LINE
0x565	R/W	0x00	[7:6]: MDBOX11_V_LINE [5:4]: MDBOX11_H_LINE [3:2]: MDBOX10_V_LINE [1:0]: MDBOX10_H_LINE
0x566	R/W	0x00	[7:6]: MDBOX13_V_LINE [5:4]: MDBOX13_H_LINE [3:2]: MDBOX12_V_LINE [1:0]: MDBOX12_H_LINE
0x567	R/W	0x00	[7:6]: MDBOX15_V_LINE [5:4]: MDBOX15_H_LINE [3:2]: MDBOX14_V_LINE [1:0]: MDBOX14_H_LINE
0x568	R/W	0x00	MDBOX0_HL[7:0]
0x569	R/W	0x00	MDBOX0_HL[10:8]
0x56A	R/W	0x00	MDBOX1_HL[7:0]
0x56B	R/W	0x00	MDBOX1_HL[10:8]
0x56C	R/W	0x00	MDBOX2_HL[7:0]
0x56D	R/W	0x00	MDBOX2_HL[10:8]
0x56E	R/W	0x00	MDBOX3_HL[7:0]
0x56F	R/W	0x00	MDBOX3_HL[10:8]
0x570	R/W	0x00	MDBOX4_HL[7:0]
0x571	R/W	0x00	MDBOX4_HL[10:8]
0x572	R/W	0x00	MDBOX5_HL[7:0]
0x573	R/W	0x00	MDBOX5_HL[10:8]
0x574	R/W	0x00	MDBOX6_HL[7:0]
0x575	R/W	0x00	MDBOX6_HL[10:8]
0x576	R/W	0x00	MDBOX7_HL[7:0]
0x577	R/W	0x00	MDBOX7_HL[10:8]
0x578	R/W	0x00	MDBOX8_HL[7:0]
0x579	R/W	0x00	MDBOX8_HL[10:8]
0x57A	R/W	0x00	MDBOX9_HL[7:0]
0x57B	R/W	0x00	MDBOX9_HL[10:8]
0x57C	R/W	0x00	MDBOX10_HL[7:0]
0x57D	R/W	0x00	MDBOX10_HL[10:8]
0x57E	R/W	0x00	MDBOX11_HL[7:0]
0x57F	R/W	0x00	MDBOX11_HL[10:8]
0x580	R/W	0x00	MDBOX12_HL[7:0]
0x581	R/W	0x00	MDBOX12_HL[10:8]

Address	R/W	Default	Description
0x582	R/W	0x00	MDBOX13_HL[7:0]
0x583	R/W	0x00	MDBOX13_HL[10:8]
0x584	R/W	0x00	MDBOX14_HL[7:0]
0x585	R/W	0x00	MDBOX14_HL[10:8]
0x586	R/W	0x00	MDBOX15_HL[7:0]
0x587	R/W	0x00	MDBOX15_HL[10:8]
0x588	R/W	0x00	MDBOX0_VT[7:0]
0x589	R/W	0x00	MDBOX0_VT[10:8]
0x58A	R/W	0x00	MDBOX1_VT[7:0]
0x58B	R/W	0x00	MDBOX1_VT[10:8]
0x58C	R/W	0x00	MDBOX2_VT[7:0]
0x58D	R/W	0x00	MDBOX2_VT[10:8]
0x58E	R/W	0x00	MDBOX3_VT[7:0]
0x58F	R/W	0x00	MDBOX3_VT[10:8]
0x590	R/W	0x00	MDBOX4_VT[7:0]
0x591	R/W	0x00	MDBOX4_VT[10:8]
0x592	R/W	0x00	MDBOX5_VT[7:0]
0x593	R/W	0x00	MDBOX5_VT[10:8]
0x594	R/W	0x00	MDBOX6_VT[7:0]
0x595	R/W	0x00	MDBOX6_VT[10:8]
0x596	R/W	0x00	MDBOX7_VT[7:0]
0x597	R/W	0x00	MDBOX7_VT[10:8]
0x598	R/W	0x00	MDBOX8_VT[7:0]
0x599	R/W	0x00	MDBOX8_VT[10:8]
0x59A	R/W	0x00	MDBOX9_VT[7:0]
0x59B	R/W	0x00	MDBOX9_VT[10:8]
0x59C	R/W	0x00	MDBOX10_VT[7:0]
0x59D	R/W	0x00	MDBOX10_VT[10:8]
0x59E	R/W	0x00	MDBOX11_VT[7:0]
0x59F	R/W	0x00	MDBOX11_VT[10:8]
0x5A0	R/W	0x00	MDBOX12_VT[7:0]
0x5A1	R/W	0x00	MDBOX12_VT[10:8]
0x5A2	R/W	0x00	MDBOX13_VT[7:0]
0x5A3	R/W	0x00	MDBOX13_VT[10:8]
0x5A4	R/W	0x00	MDBOX14_VT[7:0]
0x5A5	R/W	0x00	MDBOX14_VT[10:8]
0x5A6	R/W	0x00	MDBOX15_VT[7:0]
0x5A7	R/W	0x00	MDBOX15_VT[10:8]
0x5A8	R/W	0x00	MDBOX0_HS[7:0]
0x5A9	R/W	0x00	MDBOX0_HS[10:8]
0x5AA	R/W	0x00	MDBOX1_HS[7:0]
0x5AB	R/W	0x00	MDBOX1_HS[10:8]
0x5AC	R/W	0x00	MDBOX2_HS[7:0]
0x5AD	R/W	0x00	MDBOX2_HS[10:8]
0x5AE	R/W	0x00	MDBOX3_HS[7:0]
0x5AF	R/W	0x00	MDBOX3_HS[10:8]
0x5B0	R/W	0x00	MDBOX4_HS[7:0]
0x5B1	R/W	0x00	MDBOX4_HS[10:8]
0x5B2	R/W	0x00	MDBOX5_HS[7:0]
0x5B3	R/W	0x00	MDBOX5_HS[10:8]
0x5B4	R/W	0x00	MDBOX6_HS[7:0]
0x5B5	R/W	0x00	MDBOX6_HS[10:8]

Address	R/W	Default	Description
0x5B6	R/W	0x00	MDBOX7_HS[7:0]
0x5B7	R/W	0x00	MDBOX7_HS[10:8]
0x5B8	R/W	0x00	MDBOX8_HS[7:0]
0x5B9	R/W	0x00	MDBOX8_HS[10:8]
0x5BA	R/W	0x00	MDBOX9_HS[7:0]
0x5BB	R/W	0x00	MDBOX9_HS[10:8]
0x5BC	R/W	0x00	MDBOX10_HS[7:0]
0x5BD	R/W	0x00	MDBOX10_HS[10:8]
0x5BE	R/W	0x00	MDBOX11_HS[7:0]
0x5BF	R/W	0x00	MDBOX11_HS[10:8]
0x5C0	R/W	0x00	MDBOX12_HS[7:0]
0x5C1	R/W	0x00	MDBOX12_HS[10:8]
0x5C2	R/W	0x00	MDBOX13_HS[7:0]
0x5C3	R/W	0x00	MDBOX13_HS[10:8]
0x5C4	R/W	0x00	MDBOX14_HS[7:0]
0x5C5	R/W	0x00	MDBOX14_HS[10:8]
0x5C6	R/W	0x00	MDBOX15_HS[7:0]
0x5C7	R/W	0x00	MDBOX15_HS[10:8]
0x5C8	R/W	0x00	MDBOX0_VS[7:0]
0x5C9	R/W	0x00	MDBOX0_VS[10:8]
0x5CA	R/W	0x00	MDBOX1_VS[7:0]
0x5CB	R/W	0x00	MDBOX1_VS[10:8]
0x5CC	R/W	0x00	MDBOX2_VS[7:0]
0x5CD	R/W	0x00	MDBOX2_VS[10:8]
0x5CE	R/W	0x00	MDBOX3_VS[7:0]
0x5CF	R/W	0x00	MDBOX3_VS[10:8]
0x5D0	R/W	0x00	MDBOX4_VS[7:0]
0x5D1	R/W	0x00	MDBOX4_VS[10:8]
0x5D2	R/W	0x00	MDBOX5_VS[7:0]
0x5D3	R/W	0x00	MDBOX5_VS[10:8]
0x5D4	R/W	0x00	MDBOX6_VS[7:0]
0x5D5	R/W	0x00	MDBOX6_VS[10:8]
0x5D6	R/W	0x00	MDBOX7_VS[7:0]
0x5D7	R/W	0x00	MDBOX7_VS[10:8]
0x5D8	R/W	0x00	MDBOX8_VS[7:0]
0x5D9	R/W	0x00	MDBOX8_VS[10:8]
0x5DA	R/W	0x00	MDBOX9_VS[7:0]
0x5DB	R/W	0x00	MDBOX9_VS[10:8]
0x5DC	R/W	0x00	MDBOX10_VS[7:0]
0x5DD	R/W	0x00	MDBOX10_VS[10:8]
0x5DE	R/W	0x00	MDBOX11_VS[7:0]
0x5DF	R/W	0x00	MDBOX11_VS[10:8]
0x5E0	R/W	0x00	MDBOX12_VS[7:0]
0x5E1	R/W	0x00	MDBOX12_VS[10:8]
0x5E2	R/W	0x00	MDBOX13_VS[7:0]
0x5E3	R/W	0x00	MDBOX13_VS[10:8]
0x5E4	R/W	0x00	MDBOX14_VS[7:0]
0x5E5	R/W	0x00	MDBOX14_VS[10:8]
0x5E6	R/W	0x00	MDBOX15_VS[7:0]
0x5E7	R/W	0x00	MDBOX15_VS[10:8]
0x5E8	R/W	0xFF	[7:4]: MDBOX1_HCELL [3:0]: MDBOX0_HCELL

Address	R/W	Default	Description
0x5E9	R/W	0xFF	[7:4]: MDBOX3_HCELL [3:0]: MDBOX2_HCELL
0x5EA	R/W	0xFF	[7:4]: MDBOX5_HCELL [3:0]: MDBOX4_HCELL
0x5EB	R/W	0xFF	[7:4]: MDBOX7_HCELL [3:0]: MDBOX6_HCELL
0x5EC	R/W	0xFF	[7:4]: MDBOX9_HCELL [3:0]: MDBOX8_HCELL
0x5ED	R/W	0xFF	[7:4]: MDBOX11_HCELL [3:0]: MDBOX10_HCELL
0x5EE	R/W	0xFF	[7:4]: MDBOX13_HCELL [3:0]: MDBOX12_HCELL
0x5EF	R/W	0xFF	[7:4]: MDBOX15_HCELL [3:0]: MDBOX14_HCELL
0x5F0	R/W	0xBB	[7:4]: MDBOX1_VCELL [3:0]: MDBOX0_VCELL
0x5F1	R/W	0xBB	[7:4]: MDBOX3_VCELL [3:0]: MDBOX2_VCELL
0x5F2	R/W	0xBB	[7:4]: MDBOX5_VCELL [3:0]: MDBOX4_VCELL
0x5F3	R/W	0xBB	[7:4]: MDBOX7_VCELL [3:0]: MDBOX6_VCELL
0x5F4	R/W	0xBB	[7:4]: MDBOX9_VCELL [3:0]: MDBOX8_VCELL
0x5F5	R/W	0xBB	[7:4]: MDBOX11_VCELL [3:0]: MDBOX10_VCELL
0x5F6	R/W	0xBB	[7:4]: MDBOX13_VCELL [3:0]: MDBOX12_VCELL
0x5F7	R/W	0xBB	[7:4]: MDBOX15_VCELL [3:0]: MDBOX14_VCELL
0x5F8	R/W	0x00	[7:4]: CUR1_HPOS [3:0]: CUR0_HPOS
0x5F9	R/W	0x00	[7:4]: CUR3_HPOS [3:0]: CUR2_HPOS
0x5FA	R/W	0x00	[7:4]: CUR5_HPOS [3:0]: CUR4_HPOS
0x5FB	R/W	0x00	[7:4]: CUR7_HPOS [3:0]: CUR6_HPOS
0x5FC	R/W	0x00	[7:4]: CUR9_HPOS [3:0]: CUR8_HPOS
0x5FD	R/W	0x00	[7:4]: CUR11_HPOS [3:0]: CUR10_HPOS
0x5FE	R/W	0x00	[7:4]: CUR13_HPOS [3:0]: CUR12_HPOS
0x5FF	R/W	0x00	[7:4]: CUR15_HPOS [3:0]: CUR14_HPOS

Register

DE-INTERLACE MODE SELECTION REGISTER 1 – 0X400

Bit	R/W	Default	Description
7:4	R/W	0x1	rg_afm_ctl [7]: debug_alpha, internal use only [6]: disable_line_conv, internal use only [5]: disable 32 pulldown 1: Turn off 32 pulldown detection. 0: Turn on 32 pulldown detection. [4]: disable 22 pulldown 1: Turn off 22 Pulldown detection 0: Turn on 22 pulldown detection.
3	R/W	0	WEAVE_UP_EN: Weave mode up-scaler on/off control 1 = turn on up-scaler 0 = turn off up-scaler
2	R/W	0	rg_dl_use_bob 1: Use BOB for 2D de-interlace. 0: Use low angle 2D de-interlace.
1	R/W	0	rg_dl_use_3field 1 = use 3 fields for de-interlace 0 = use 5 fields for de-interlace
0	R/W	0	rg_force_2ddl 1 = turn off 3D de-interlace, use 2D de-interlace 0 = turn on 3D de-interlace

ERROR BUFFER BASE LOW BYTE REGISTER – 0X401

Bit	R/W	Default	Description
7:0	R/W	0x00	rg_dl_err_base [7:0] Start address of error field buffer allocated in the SDRAM. This number is in unit of 8 bytes. [23:22] is bank address. (2048 x height x 2) / 8

ERROR BUFFER BASE MIDDLE BYTE REGISTER – 0X402

Bit	R/W	Default	Description
7:0	R/W	0x00	rg_dl_err_base [15:8] Start address of error field buffer allocated in the SDRAM. This number is in unit of 8 bytes. [23:22] is bank address. (2048 x height x 2) / 8

ERROR BUFFER BASE HIGH BYTE REGISTER – 0X403

Bit	R/W	Default	Description
7:0	R/W	0x00	rg_dl_err_base [23:16] Start address of error field buffer allocated in the SDRAM. This number is in unit of 8 bytes. [23:22] is bank address. (2048 x height x 2) / 8

HEIGHT OF ONE FIELD IN BUFFER REGISTER LOW BYTE – 0X404

Bit	R/W	Default	Description
7:0	R/W	0xF0	rg_man_wr_height [7:0] This number specifies the number of lines in the field. It is half of frame height.

HEIGHT OF ONE FIELD IN BUFFER REGISTER HIGH BYTE – 0X405

Bit	R/W	Default	Description
7:3	R	0x0	Reserved
2:0	R/W	0x0	rg_man_wr_height [10:8] This number specifies the number of lines in the field. It is half of frame height.

WIDTH OF ONE FIELD IN BUFFER REGISTER LOW BYTE – 0X406

Bit	R/W	Default	Description
7:0	R/W	0xD0	rg_man_wr_width [7:0] This number specifies the number of pixels per line in the buffer.

WIDTH OF ONE FIELD IN BUFFER REGISTER HIGH BYTE – 0X407

Bit	R/W	Default	Description
7:3	R	0x0	Reserved
2:0	R/W	0x2	rg_man_wr_width [10:8] This number specifies the number of pixels per line in the buffer.

3D DE-INTERLACE DITB0 REGISTER – 0X408

Bit	R/W	Default	Description
7	R	0x0	Reserved
6:0	R/W	0x00	rg_ditb0

3D DE-INTERLACE DITB4 REGISTER – 0X409

Bit	R/W	Default	Description
7	R	0x0	Reserved
6:0	R/W	0x04	rg_ditb4

3D DE-INTERLACE DITB8 REGISTER - 0X40A

Bit	R/W	Default	Description
7	R	0x0	Reserved
6:0	R/W	0x08	rg_ditb8

3D DE-INTERLACE DITB12 REGISTER - 0X40B

Bit	R/W	Default	Description
7	R	0x0	Reserved
6:0	R/W	0x0C	rg_ditb12

3D DE-INTERLACE DITB16 REGISTER - 0X40C

Bit	R/W	Default	Description
7	R	0x0	Reserved
6:0	R/W	0x40	rg_ditb16

3D DE-INTERLACE DITB24 REGISTER - 0X40D

Bit	R/W	Default	Description
7	R	0x0	Reserved
6:0	R/W	0x40	rg_ditb24

3D DE-INTERLACE DITB32 REGISTER - 0X40E

Bit	R/W	Default	Description
7	R	0x0	Reserved
6:0	R/W	0x40	rg_ditb32

3D DE-INTERLACE DITB48 REGISTER - 0X40F

Bit	R/W	Default	Description
7	R	0x0	Reserved
6:0	R/W	0x40	rg_ditb48

3D DE-INTERLACE AFM_YF02_THD REGISTER - 0X410

Bit	R/W	Default	Description
7:0	R/W	0x30	rg_afm_yf02_thd

3D DE-INTERLACE AFM_YF02_H_THD REGISTER - 0X411

Bit	R/W	Default	Description
7:0	R/W	0x68	rg_afm_yf02_h_thd

3D DE-INTERLACE AFM_YF01_THD REGISTER - 0X412

Bit	R/W	Default	Description
7:0	R/W	0x08	rg_afm_yf01_thd

3D DE-INTERLACE AFM_YF01_H_THD REGISTER - 0X413

Bit	R/W	Default	Description
-----	-----	---------	-------------

7:0	R/W	0x80	rg_afm_yf01_h_thd
-----	-----	------	-------------------

3D DE-INTERLACE 32 CAPTION THRESHOLD REGISTER – 0X414

Bit	R/W	Default	Description
7:0	R/W	0x01	rg_32_caption_thd

UP-SCALE CONTROL REGISTER – 0X415

Bit	R/W	Default	Description
7:4	R/W	0x0	rg_ups1_vsharp_gain There is a sharpener before upscaler. This register controls the sharpening weighting.
3:2	R/W	0x0	Reserved
1	R/W	0x0	rg_ups1_vlimit_on 1 = remove overshoot 0 = turn off overshoot removal
0	R/W	0x0	rg_disable_man_disp 1 = black out the panel 0 = normal operation

UP-SCALE BACKGROUND COLOR – 0X416

Bit	R/W	Default	Description
7:0	R/W	0x00	rg_BGcolor The background color used when there is no valid data in the main stream. This is also the color used in the border of the video window. The color is specified as 2 bit Y, 3 bit Cb, 2 bit Cr

UP-SCALE HORIZONTAL FACTOR LOW BYTE REGISTER – 0X417

Bit	R/W	Default	Description
7:0	R/W	0x00	rg_ups1_hscale [7:0] When rg_ups1_hscale == 0x1000, the horizontal scaling factor is 1. When rg_ups1_hscale is any number smaller than 0x1000, the main path picture is up scaled horizontally. When rg_ups1_hscale is larger than 0x1000, the main video window is down scaled horizontally. The down scaling has to be less than 0x2000

UP-SCALE HORIZONTAL FACTOR HIGH BYTE REGISTER – 0X418

Bit	R/W	Default	Description
7:5	R	0x0	Reserved
4:0	R/W	0x10	rg_ups1_hscale [12:8] When rg_ups1_hscale == 0x1000, the horizontal scaling factor is 1. When rg_ups1_hscale is any number smaller than 0x1000, the main path picture is up scaled horizontally. When rg_ups1_hscale is greater than 0x1000, the main video window is down scaled horizontally. The down scaling has to be less than 0x2000

UP-SCALE VERTICAL FACTOR LOW BYTE REGISTER – 0X419

Bit	R/W	Default	Description
7:0	R/W	0x00	rg_ups1_vscale [7:0] When rg_ups1_vscale == 0x400, the vertical scaling factor is 1 When rg_ups1_vscale is any number smaller than 0x400, the main path picture is up scaled vertically. When rg_ups1_vscale is any number greater than 0x400, the main path picture is down scaled vertically The downscaling has to be less than 0x500

UP-SCALE VERTICAL FACTOR HIGH BYTE REGISTER – 0X41A

Bit	R/W	Default	Description
7:3	R	0x0	Reserved
2:0	R/W	0x4	rg_ups1_vscale [10:8] When rg_ups1_vscale == 0x400, the vertical scaling factor is 1 When rg_ups1_vscale is any number smaller than 0x400, the main path picture is up scaled vertically. When rg_ups1_vscale is any number greater than 0x400, the main path picture is down scaled vertically The downscaling has to be less than 0x500

UP-SCALE HORIZONTAL START LOW BYTE REGISTER – 0X41B

Bit	R/W	Default	Description
7:0	R/W	0x00	rg_ups1_xst [7:0] Main Video Window Horizontal Starting location, unit is pixel

UP-SCALE HORIZONTAL START HIGH BYTE REGISTER – 0X41C

Bit	R/W	Default	Description
7:3	R	0x0	Reserved
2:0	R/W	0x0	rg_ups1_xst [10:8] Main Video Window Horizontal Starting location, unit is pixel

UP-SCALE VERTICAL START LOW BYTE REGISTER – 0X41D

Bit	R/W	Default	Description
7:0	R/W	0x00	rg_ups1_Yst [7:0] Main Video Window Vertical Starting location, unit is line

UP-SCALE VERTICAL START HIGH BYTE REGISTER – 0X41E

Bit	R/W	Default	Description
7:3	R	0x0	Reserved
2:0	R/W	0x0	rg_ups1_Yst [10:8] Main Video Window Vertical Starting location, unit is line

UP-SCALE OUTPUT WIDTH LOW BYTE REGISTER – 0X41F

Bit	R/W	Default	Description
7:0	R/W	0xD0	rg_ups1_Xmax [7:0] Main Video Window width after scaling, unit is pixel

UP-SCALE OUTPUT WIDTH HIGH BYTE REGISTER – 0X420

Bit	R/W	Default	Description
7:3	R	0x0	Reserved
2:0	R/W	0x2	rg_ups1_Xmax [10:8] Main Video Window width after scaling, unit is pixel

UP-SCALE OUTPUT HEIGHT LOW BYTE REGISTER – 0X421

Bit	R/W	Default	Description
7:0	R/W	0xE0	rg_ups1_Ymax [7:0] Main Video Window height after scaling, unit is line

UP-SCALE OUTPUT HEIGHT HIGH BYTE REGISTER – 0X422

Bit	R/W	Default	Description
7:3	R	0x0	Reserved
2:0	R/W	0x1	rg_ups1_Ymax [10:8] Main Video Window height after scaling, unit is line

UP-SCALE X BOUNDARY WIDTH REGISTER – 0X423

Bit	R/W	Default	Description
7:0	R/W	0x00	rg_ups1_Xoff Main Video Window horizontal colored boundary width. When the panorama / Water glass mode is on, this offset specifies the width of the band at two side of the picture that will be scaled into panorama / water glass

UP-SCALE Y BOUNDARY WIDTH REGISTER – 0X424

Bit	R/W	Default	Description
7:0	R/W	0x00	rg_ups1_Yoff Main Video Window vertical colored boundary width.

UP-SCALE PANORAMA / WATER GLASS CONTROL REGISTER – 0X425

Bit	R/W	Default	Description
7	R/W	0x0	rg_ups1_panorama 1 = Enable Panorama / Water glass scaling. 0 = Disable Panorama / Water glass scaling
6	R/W	0x0	rg_ups1_hs_type 0 = Concave (Panorama) 1 = Convex (Water Glass)
5:4	R/W	0x0	rg_ups1_hs_step When Panorama / Water glass is on, the scaling factor increased/decreased every N pixels at the input side. 0 : N = 1, 1: N = 2, 2: N = 4, 3: N = 8.
3:0	R/W	0x0	rg_ups1_hs_inc The scaling factor change between steps of input pixels as specified in bit 5:4. This change is added/subtracted from the scaling factor of the previous step closer to the center.

UP-SCALE HORIZONTAL CENTER SCALE FACTOR LOW BYTE REGISTER – 0X426

Bit	R/W	Default	Description
7:0	R/W	0x00	rg_ups1_hs_center [7:0] The scaling factor at the center portion. When panorama/water glass mode is on, the horizontal scaling factor rg_ups1_hscale is not used. Instead, rg_ups1_hs_center is used for the center portion.

UP-SCALE HORIZONTAL CENTER SCALE FACTOR HIGH BYTE REGISTER – 0X427

Bit	R/W	Default	Description
7:5	R	0x00	Reserved
4:0	R/W	0x00	rg_ups1_hs_center [12:8] The scaling factor at the center portion. When panorama/water glass mode is on, the horizontal scaling factor rg_ups1_hscale is not used. Instead, rg_ups1_hs_center is used for the center portion.

2D DE-INTERLACE CONTROL REGISTER – 0X428

Bit	R/W	Default	Description
7:0	R/W	0x00	rg_2ddi_ctl

2D DE-INTERLACE THRESHOLD 1 REGISTER – 0X429

Bit	R/W	Default	Description
7:0	R/W	0x28	rg_2ddi_thd1

2D DE-INTERLACE THRESHOLD 2 REGISTER – 0X42A

Bit	R/W	Default	Description
7:0	R/W	0x1E	rg_2ddi_thd2

2D DE-INTERLACE THRESHOLD 3 REGISTER – 0X42B

Bit	R/W	Default	Description
7:0	R/W	0x28	rg_2ddi_thd3

2D DE-INTERLACE THRESHOLD 4 REGISTER – 0X42C

Bit	R/W	Default	Description
7:0	R/W	0x28	rg_2ddi_thd4

2D DE-INTERLACE THRESHOLD 5 REGISTER – 0X42D

Bit	R/W	Default	Description
7:0	R/W	0x24	rg_2ddi_thd5

2D DE-INTERLACE THRESHOLD 6 REGISTER – 0X42E

Bit	R/W	Default	Description
7:0	R/W	0x6F	rg_2ddi_thd6

3D DE-INTERLACE CONTROL REGISTER – 0X42F

Bit	R/W	Default	Description
7:0	R/W	0x00	rg_3ddi_ctl

3D DE-INTERLACE THRESHOLD 1 REGISTER – 0X430

Bit	R/W	Default	Description
7:0	R/W	0x0A	rg_3ddi_thd1

3D DE-INTERLACE THRESHOLD 2 REGISTER – 0X431

Bit	R/W	Default	Description
7:0	R/W	0x95	rg_3ddi_thd2

UPSCALER OPTION REGISTER – 0X432

Bit	R/W	Default	Description
7:2	R	0	Reserved
1	R/W	0	Ups1_dbg[1] Vertical upscale parameter select
0	R/W	0	Ups1_dbg[0] Horizontal upscale parameter select

SINGLE BOX 4 TO 7 REGISTER – 0X440 TO 0X46B

Single box 4 to 7 are same as single box 0 to 3. Please refer to register 0x50C 0x538

MOUSE BASE ADDRESS LOW BYTE REGISTER – 0X46C

Bit	R/W	Default	Description
7:0	R/W	0x00	MOUSE_BASE_ADDR[7:0] There are 16 mouse shape can be written to SDRAM. This is address for the first mouse. All mouse data is continuous. This address is 8 bytes unit.

MOUSE BASE ADDRESS MIDDLE BYTE REGISTER – 0X46D

Bit	R/W	Default	Description
7:0	R/W	0x00	MOUSE_BASE_ADDR[15:8] There are 16 mouse shape can be written to SDRAM. This is address for the first mouse. All mouse data is continuous. This address is 8 bytes unit.

MOUSE BASE ADDRESS HIGH BYTE REGISTER – 0X46E

Bit	R/W	Default	Description
7:0	R/W	0x00	MOUSE_BASE_ADDR[23:16] There are 16 mouse shape can be written to SDRAM. This is address for the first mouse. All mouse data is continuous. This address is 8 bytes unit.

MOUSE UPDATE ENABLE REGISTER – 0X46F

Bit	R/W	Default	Description
7:1	R	0	Reserved
0	R/W	0	MOUSE_UPDATE_EN Set this bit to high, hardware will automatically load mouse data from SDRAM to local SRAM. This bit will be clear when load is done.

MOUSE INDEX REGISTER – 0X470

Bit	R/W	Default	Description
7:5	R	0	Reserved
4	R/W	0	MOUSE_BUF : This bit select which buffer will be updated. 0: first mouse buffer 1: second mouse buffer
3:0	R/W	0	MOUSE_INDEX[3:0] This register set which mouse shape will be loaded from SDRAM. Up to 16 mouse shapes can be saved in SDRAM. If user wants more than 16 mouse shape, user can set different mouse base address.

WINDOW 32 VERTICAL POSITION REGISTER LOW BYTE – 0X472

Bit	R/W	Default	Description
7:0	R/W	0	VPOS_32[7:0] Window 32 vertical position. This window will show memory content instead of video. It can be used for LOGO display. 1 line unit.

WINDOW 32 HORIZONTAL POSITION REGISTER LOW BYTE – 0X473

Bit	R/W	Default	Description
7:0	R/W	0	HPOS_32[7:0] Window 32 horizontal position. This window will show memory content instead of video. It can be used for LOGO display. 4 pixels unit.

WINDOW 32 VERTICAL SIZE REGISTER LOW BYTE – 0X474

Bit	R/W	Default	Description
7:0	R/W	0	VSIZE_32[7:0] Window 32 vertical size. This window will show memory content instead of video. It can be used for LOGO display. 1 line unit.

WINDOW 32 HORIZONTAL SIZE REGISTER LOW BYTE – 0X475

Bit	R/W	Default	Description
7:0	R/W	0	HSIZE_32[7:0] Window 32 horizontal size. This window will show memory content instead of video. It can be used for LOGO display. 4 pixels unit.

WINDOW 32 VERTICAL AND HORIZONTAL POSITION REGISTER HIGH BYTE – 0X476

Bit	R/W	Default	Description
7:6	R	0	Reserved
5:4	R/W	0	HPOS_32[9:8] Window 32 horizontal position. This window will show memory content instead of video. It can be used for LOGO display. 4 pixels unit.
3:0	R/W	0	VPOS_32[11:8] Window 32 vertical position. This window will show memory content instead of video. It can be used for LOGO display. 1 line unit.

WINDOW 32 VERTICAL AND HORIZONTAL SIZE REGISTER HIGH BYTE – 0X477

Bit	R/W	Default	Description
7:5	R	0	Reserved
4	R/W	0	HSIZE_32[8] Window 32 horizontal size. This window will show memory content instead of video. It can be used for LOGO display. 4 pixels unit.
2:0	R/W	0	VSIZE_32[10:8] Window 32 vertical size. This window will show memory content instead of video. It can be used for LOGO display. 1 line unit.

Register 0x478 to 0x47D are for dual monitor window 32.

WINDOW 32 ENABLE REGISTER – 0X47E

Bit	R/W	Default	Description
7:2	R	0	Reserved
1	R/W	0	CH32_BND_EN Window 32 boundary enable
0	R/W	0	CH32_EN Window 32 DRAM data display enable

Register 0x47F is for dual monitor window 32.

DISPLAY MISC. CONTROL REGISTER – 0X480

Bit	R/W	Default	Description
7	R/W	1	OUT_DIS Output disable. If set to high, VGA output will have all signals low.
6	R/W	0	MDBOX_POS_SEL Motion box position selection. If set to high, motion box position is automatically set to channel position
5	R/W	0	Reserved
4	R/W	0	BND_EN Channel boundary enable. Only enabled channel has boundary.
3	R/W	0	COLBAR_EN Color bar enable. Output is color bar instead of live video.
2	R/W	0	SWITCH_EN Switch to SDRAM contents if channel is disabled. If this bit is set to low, disabled channel will show background. If this bit is set to high, background is not shown. The contents in SDRAM will shows up. This is used for debug
1	R/W	0	HS_POL: Horizontal sync polarity 1: positive 0: negative
0	R/W	0	VS_POL: Vertical sync polarity 1: positive 0: negative

VERTICAL SYNC DELAY AND BOUNDARY WIDTH REGISTER – 0X481

Bit	R/W	Default	Description
7:4	R/W	0x02	BND_WIDTH Boundary width. Unit is pixel.
3:0	R/W	0x0F	VSDDEL Vertical sync delay cycle after horizontal sync

BOUNDARY RED COLOR INTENSITY REGISTER – 0X482

Bit	R/W	Default	Description
7:0	R/W	0xFF	BND_R[7:0] Boundary red color.

BOUNDARY GREEN COLOR INTENSITY REGISTER – 0X483

Bit	R/W	Default	Description
7:0	R/W	0xFF	BND_G[7:0] Boundary green color.

BOUNDARY BLUE COLOR INTENSITY REGISTER – 0X484

Bit	R/W	Default	Description
7:0	R/W	0xFF	BND_B[7:0] Boundary blue color.

HORIZONTAL UPSCALE FACTOR LOW BYTE REGISTER – 0X485

Bit	R/W	Default	Description
7:0	R/W	0x00	POS_HSCALE[7:0] Channel position information upscale factor. 0x1000 means no upscale. Value more than 0x1000 means upscale. If image is upscaled, this register must be set correctly.

HORIZONTAL UPSCALE FACTOR HIGH BYTE REGISTER – 0X486

Bit	R/W	Default	Description
7:0	R/W	0x10	POS_HSCALE[15:8] Channel position information upscale factor. 0x1000 means no upscale. Value more than 0x1000 means upscale. If image is upscaled, this register must be set correctly.

VERTICAL UPSCALE FACTOR LOW BYTE REGISTER – 0X487

Bit	R/W	Default	Description
7:0	R/W	0x00	POS_VSCALE[7:0] Channel position information upscale factor. 0x1000 means no upscale. Value more than 0x1000 means upscale. If image is upscaled, this register must be set correctly.

VERTICAL UPSCALE FACTOR HIGH BYTE REGISTER – 0X488

Bit	R/W	Default	Description
7:0	R/W	0x10	POS_VSCALE[15:8] Channel position information upscale factor. 0x1000 means no upscale. Value more than 0x1000 means upscale. If image is upscaled, this register must be set correctly.

POSITION UPSCALE ENABLE REGISTER – 0X489

Bit	R/W	Default	Description
7:1	R	0	Reserved
0	R/W	0	POS_UPS_EN Use upscaled position information if this bit set to high.

OSD BLINK RATE REGISTER – 0X48A

Bit	R/W	Default	Description
7:2	R	0	Reserved
1:0	R/W	0x00	OSD_BLINK_TIME: OSD blinking frequency control 00: blinking on each 32 frames 01: blinking on each 16 frames 10: blinking on each 8 frames 11: blinking on each 4 frames

MOTION BOX CURSOR VERTICAL POSITION REGISTER – 0X48B

Bit	R/W	Default	Description
7:4	R/W	0	CUR1_VPOS[3:0] Channel 1 Cursor Vertical Position
3:0	R/W	0	CUR0_VPOS[3:0] Channel 0 Cursor Vertical Position

Similar registers are assigned to control channel 2 to 16 using register 0x48C – 0x492 respectively.

MOTION BOX OUT BOUNDARY RED COLOR REGISTER – 0X493

Bit	R/W	Default	Description
7:0	R/W	0	MDBOX_OBR[7:0] Red color for motion box out boundary

MOTION BOX OUT BOUNDARY GREEN COLOR REGISTER – 0X494

Bit	R/W	Default	Description
7:0	R/W	0	MDBOX_OBG[7:0] Green color for motion box out boundary

MOTION BOX OUT BOUNDARY BLUE COLOR REGISTER – 0X495

Bit	R/W	Default	Description
7:0	R/W	0	MDBOX_OBB[7:0] Blue color for motion box out boundary

MOTION BOX INNER BOUNDARY RED COLOR REGISTER – 0X496

Bit	R/W	Default	Description
7:0	R/W	0	MDBOX_IBR[7:0] Red color for motion box Inner boundary

MOTION BOX INNER BOUNDARY GREEN COLOR REGISTER – 0X497

Bit	R/W	Default	Description
7:0	R/W	0	MDBOX_IBG[7:0] Green color for motion box Inner boundary

MOTION BOX INNER BOUNDARY BLUE COLOR REGISTER – 0X498

Bit	R/W	Default	Description
7:0	R/W	0	MDBOX_IBB[7:0] Blue color for motion box Inner boundary

MOTION BOX MASK RED COLOR REGISTER – 0X499

Bit	R/W	Default	Description
7:0	R/W	0	MDBOX_MSKR[7:0] Red color for motion box mask area

MOTION BOX MASK GREEN COLOR REGISTER – 0X49A

Bit	R/W	Default	Description
7:0	R/W	0	MDBOX_MSKG[7:0] Green color for motion box mask area

MOTION BOX MASK BLUE COLOR REGISTER – 0X49B

Bit	R/W	Default	Description
7:0	R/W	0	MDBOX_MSKB[7:0] Blue color for motion box mask area

MOTION BOX PLANE RED COLOR REGISTER – 0X49C

Bit	R/W	Default	Description
7:0	R/W	0	MDBOX_PR[7:0] Red color for motion box plane area

MOTION BOX PLANE GREEN COLOR REGISTER – 0X49D

Bit	R/W	Default	Description
7:0	R/W	0	MDBOX_PG[7:0] Green color for motion box plane area

MOTION BOX PLANE BLUE COLOR REGISTER – 0X49E

Bit	R/W	Default	Description
7:0	R/W	0	MDBOX_PB[7:0] Blue color for motion box plane area

HORIZONTAL START LOW BYTE REGISTER – 0X4A0

Bit	R/W	Default	Description
7:0	R/W	0	HSTART[7:0] Horizontal start in SDARM for read out. Unit is 4 pixels

HORIZONTAL START HIGH BYTE REGISTER – 0X4A1

Bit	R/W	Default	Description
7:2	RO	-	Reserved
1:0	R/W	0	HSTART[9:8] Horizontal start in SDARM for read out. Unit is 4 pixels

VERTICAL START LOW BYTE REGISTER – 0X4A2

Bit	R/W	Default	Description
7:0	R/W	0	VSTART[7:0] Vertical start in SDARM for read out. Unit is 1 line.

VERTICAL START HIGH BYTE REGISTER – 0X4A3

Bit	R/W	Default	Description
7:4	RO	-	Reserved
3:0	R/W	0	VSTART[11:8] Vertical start in SDARM for read out. Unit is 1 line.

RTI WINDOW REGISTER – 0X4A4

Bit	R/W	Default	Description
7:0	R/W	0xFF	VTT_WIN[7:0] Vertical Total can be changed according to input video frame rate. If difference is more than this number, VTT will not be adjusted. Unit is 1 line.

VERTICAL TOTAL ADJUST MODE REGISTER – 0X4A5

Bit	R/W	Default	Description
7:3	RO	-	Reserved
2	R/W	0x00	VTT_ADJUST It is used for manual mode. After set this bit, VTT will be changed according to current input video frame rate.
1	R/W	0	VTT_ADJUST_MODE 1: auto mode, adjust VTT each frame 0: manual mode, adjust VTT after set VTT_ADJUST
0	R/W	0	VTT_ADJUST_EN Enable VTT adjustment. If set to 0, use register setting. If set to 1, use input video frame rate.

VERTICAL TOTAL FROM INPUT VIDEO LOW BYTE REGISTER – 0X4A6

Bit	R/W	Default	Description
7:0	RO	-	NEW_VTT_RGBW[7:0] It is calculated from input video. The number is for two fields.

VERTICAL TOTAL FROM INPUT VIDEO HIGH BYTE REGISTER – 0X4A7

Bit	R/W	Default	Description
7:4	RO	-	Reserved
3:0	RO	-	NEW_VTT_RGBW[11:8] It is calculated from input video. The number is for two fields.

VERTICAL TOTAL AFTER ADJUSTMENT BYTE REGISTER – 0X4A8

Bit	R/W	Default	Description
7:0	RO	-	NEW_VTT[7:0] It is new VTT which is used in output timing. The number is for one field.

VERTICAL TOTAL AFTER ADJUSTMENT HIGH REGISTER – 0X4A9

Bit	R/W	Default	Description
7:3	RO	-	Reserved
2:0	RO	-	NEW_VTT[10:8] It is new VTT which is used in output timing. The number is for one field.

BOUNDARY ENABLE REGISTER – 0X4AA

Bit	R/W	Default	Description
7:4	R/W	0xF	BND_EN_1[3:0]: Boundary Enable for Channel 1 [0]: left side boundary enable [1]: right side boundary enable [2]: top side boundary enable [3]: bottom side boundary enable
3:0	R/W	0xF	BND_EN_0[3:0]: Boundary Enable for Channel 0 [0]: left side boundary enable [1]: right side boundary enable [2]: top side boundary enable [3]: bottom side boundary enable

Similar register 0x4AB – 0X4B3 are assigned to control channel 12 – 19 respectively.

PS2 MOUSE CONTROL REGISTER – 0X4B4

Bit	R/W	Default	Description
7:0	R/W	0xFF	PS2CON[7:0] [0]: 1 = PS2 enable [1]: 1 = Data write enable [3:2]: MaxByte [7:4]: MaxNoSig

PS2 MOUSE WRITE DATA REGISTER – 0X4B5

Bit	R/W	Default	Description
7:0	R/W	0xFF	PS2DATA_IN The data written to PS2 mouse

PS2 MOUSE WRITE DATA REGISTER 1- 0X4B6

Bit	R/W	Default	Description
7:0	R/W	-	PS2DATA_OUT[7:0] The data read from PS2 mouse

PS2 MOUSE WRITE DATA REGISTER 2- 0X4B7

Bit	R/W	Default	Description
7:0	R/W	-	PS2DATA_OUT[15:8] The data read from PS2 mouse

PS2 MOUSE WRITE DATA REGISTER 3- 0X4B8

Bit	R/W	Default	Description
7:0	R/W	-	PS2DATA_OUT[23:16] The data read from PS2 mouse

PS2 MOUSE WRITE DATA REGISTER 4– 0X4B9

Bit	R/W	Default	Description
7:0	R/W	-	PS2DATA_OUT[31:24] The data read from PS2 mouse

PS2 INTERRUPT REGISTER– 0X4BA

Bit	R/W	Default	Description
7:1	RO	-	Reserved
0	R/W	-	PS2_INT_REG 1 = PS2 interrupt. Clear by write

EXTERNAL OSD CONTROL REGISTER– 0X4BB

Bit	R/W	Default	Description
7:5	RO	-	Reserved
4	R/W	0	EOSD_SEL 0: select external OSD 1: select internal pure color
3	R/W	0	EOSD_EN 1 = External OSD enable
2	R/W	0	EOSD_MODE 0: ex_osd_en high active 1: ex_osd_en low active
1	R/W	0	EOSD_EN_DIS 0: use ex_osd_en 1: always enable, no transparent
0	R/W	0	EOSD_ALPHA_EN 1 = External OSD alpha blending enable

EXTERNAL OSD ALPHA REGISTER– 0X4BC

Bit	R/W	Default	Description
7:4	RO	-	Reserved
3:0	R/W	0	EOSD_ALPHA Alpha blending alpha number for external OSD layer. The output image will be: Video_data * alpha + eosd_data * (1 - alpha). Here alpha = OSD_ALPHA / 16. Maximum is 15.

EXTERNAL OSD COLOR R REGISTER– 0X4BD

Bit	R/W	Default	Description
7:0	R/W	0	EOSD_R Red Color for external OSD. It is used when EOSD_SEL is set to high.

EXTERNAL OSD COLOR G REGISTER- 0X4BE

Bit	R/W	Default	Description
7:0	R/W	0	EOSD_G Green Color for external OSD. It is used when EOSD_SEL is set to high.

EXTERNAL OSD COLOR B REGISTER- 0X4BF

Bit	R/W	Default	Description
7:0	R/W	0	EOSD_B Blue Color for external OSD. It is used when EOSD_SEL is set to high.

INTERRUPT MASK REGISTER- 0X4C0

Bit	R/W	Default	Description
7:4	RO	-	Reserved
3	RW	1	INT_MASK_OSG_VBLANK 1 = OSG vblank interrupt mask enable
2	R/W	1	INT_MASK_PS2 1 = PS2 interrupt mask enable
1	R/W	1	INT_MASK_OSG_BUSY 1 = OSG busy interrupt mask enable
0	R/W	1	INT_MASK_OSG_WAIT 1 = OSG wait interrupt mask enable

INTERRUPT STATUS REGISTER- 0X4C1

Bit	R/W	Default	Description
7:4	RO	-	Reserved
3	RO	-	INT_OSG_VBLANK 1 = OSG vertical blank toggle interrupt, write clear
2	RO	-	INT_PS2 1 = PS2 interrupt, write clear
1	RO	-	INT_OSG_BUSY 1 = OSG busy interrupt, write clear
0	RO	-	INT_OSG_WAIT 1 = OSG wait interrupt, write clear. When OSG write buffer (1KB) is almost empty, interrupt will be high.

FRAME RATE CONTROL DEBUG REGISTER- 0X4C2

Bit	R/W	Default	Description
7	R/W	0	rd_buf_id_toggle 1: read buffer ID always toggle between odd and even 0: odd or even can be repeat
6	R/W	0	Rd_buf_inc 1: read buffer ID free running 0: increase read buffer ID according to write buffer ID
5	R/W	0	WR_PAGE_EN Manual set write page enable, 1 = enable
4	R/W	0	RD_PAGE_EN Manual set read page enable
3:2	R/W	0	WR_PAGE Used in manual mode
1:0	R/W	0	RD_PAGE Used in manual mode

MISC CONTROL REGISTER - 0X4C3

Bit	R/W	Default	Description
7:5	R/W	3	WR_BUF_OFST This register should be set to 3.
4	R/W	0	INTERLACE_DBG Interlaced mode debugging use.
3	R/W	0	VTT_INV It is used in interlaced mode, it should be set to 0
2	R/W	0	EVEN_REPEAT 0: repeat odd or even when needed 1: repeat even only
1	R/W	0	DMON_VS_EN 0: not use dual monitor vsync 1: use dual monitor vsync. This is used when main display data goes to dual monitor display.
0	R/W	0	INTERLACE 0: progressive mode 1: interlaced mode

BOUNDARY ENABLE REGISTER 2 – 0X4C4

Bit	R/W	Default	Description
7:4	R/W	0xF	BND_EN_21[3:0]: Boundary Enable for Channel 21 [0]: left side boundary enable [1]: right side boundary enable [2]: top side boundary enable [3]: bottom side boundary enable
3:0	R/W	0xF	BND_EN_20[3:0]: Boundary Enable for Channel 20 [0]: left side boundary enable [1]: right side boundary enable [2]: top side boundary enable [3]: bottom side boundary enable

Similar register 0x4C5 – 0X4C9 are assigned to control channel 22 – 31 respectively.

IMAGE CONTROL REGISTER – 0X4CE

Bit	R/W	Default	Description
7	RO	-	Reserved
6	R/W	0	OSD_CH_EN_SEL: Simple OSD channel enable select 0: use rgb_interface channel enable 1: use another register set, [0x4F0] to [0x4F3]
5	R/W	0	NOVID_SWITCH_EN In normal case, this bit set to 0. No video color will show up. If this bit set to 1, SDRAM data will show up.
4	R/W	0	BND_CH_EN_SEL: Boundary channel enable select. 0: use rgb_interface channel enable 1: use another register set, [0x4F0] to [0x4F3]
3	R/W	1	PEAK_C_DUP: In peak module, Cb/Cr using average or using duplicate data 0: average 1: duplicate
2	R/W	0	GAIN_EN: 1 = RGB digital gain enable
1	R/W	0	PEAK_EN: 1 = Peak enable
0	R	0	Reserved

PEAK CONTROL REGISTER – 0X4D0

Bit	R/W	Default	Description
7	RO	-	Reserved
6	R/W	0	PEAK_HD_EN 1 = enable
5	R/W	1	PEAK_V_EN Peak vertical enable, 1 = enable

Bit	R/W	Default	Description
4	R/W	1	PEAK_H_EN Peak horizontal enable, 1 = enable
3:2	RO	-	Reserved
1	R/W		PEAK_DIS_V_CON2, 1 = disable
0	R/W		PEAK_DIS_V_CON1, 1 = disable

DIGITAL R GAIN REGISTER – 0X4DA

Bit	R/W	Default	Description
7:0	R/W	0x40	R_GAIN: R digital gain. 0x40 is no gain. More than 0x40 means gain more than 1.

DIGITAL G GAIN REGISTER – 0X4DB

Bit	R/W	Default	Description
7:0	R/W	0x40	G_GAIN: G digital gain. 0x40 is no gain. More than 0x40 means gain more than 1.

DIGITAL B GAIN REGISTER – 0X4DC

Bit	R/W	Default	Description
7:0	R/W	0x40	B_GAIN: B digital gain. 0x40 is no gain. More than 0x40 means gain more than 1.

R OFFSET REGISTER – 0X4DD

Bit	R/W	Default	Description
7:0	R/W	0x00	R_OFST[7:0] R offset. $R_{out} = R_{in} * R_GAIN + R_OFST$. This value is 2's complement value. R_OFST can be negative data.

G OFFSET REGISTER – 0X4DE

Bit	R/W	Default	Description
7:0	R/W	0x00	G_OFST[7:0] G offset. $R_{out} = R_{in} * R_GAIN + R_OFST$. This value is 2's complement value. R_OFST can be negative data.

B OFFSET REGISTER – 0X4DF

Bit	R/W	Default	Description
7:0	R/W	0x00	B_OFST[7:0] B offset. $R_{out} = R_{in} * R_GAIN + R_OFST$. This value is 2's complement value. R_OFST can be negative data.

BOUNDARY CHANNEL ENABLE REGISTER 1 – 0X4F0

Bit	R/W	Default	Description
7:0	RW	0	BND_CH_EN[7:0]: Control channel 7 - 0 Boundary channel enable. This register is only used when BND_CH_EN_SEL is high. This is only used when user want to show boundary when channel is not enable.

BOUNDARY CHANNEL ENABLE REGISTER 2 – 0X4F1

Bit	R/W	Default	Description
7:0	RW	0	BND_CH_EN[15:8]: Control live channel 15 - 8 Boundary channel enable. This register is only used when BND_CH_EN_SEL is high. This is only used when user want to show boundary when channel is not enable.

BOUNDARY CHANNEL ENABLE REGISTER 3 – 0X4F2

Bit	R/W	Default	Description
7:0	RW	0	BND_CH_EN[23:16]: Control live channel 23 - 16 Boundary channel enable. This register is only used when BND_CH_EN_SEL is high. This is only used when user want to show boundary when channel is not enable.

BOUNDARY CHANNEL ENABLE REGISTER 4 – 0X4F3

Bit	R/W	Default	Description
7:0	RW	0	BND_CH_EN[31:24]: Control live channel 31 - 24 Boundary channel enable. This register is only used when BND_CH_EN_SEL is high. This is only used when user want to show boundary when channel is not enable.

FRAME RATE CONTROL ENABLE REGISTER 1 – 0X4F4

Bit	R/W	Default	Description
7:0	RW	0xFF	FRSC_CH_EN[7:0]: Control live channel 7 - 0 This register and the next three forms a group. These 32 bits will determine which channel are included in the frame rate control decision. This is only for debugging purpose. In default, all channels will be included.

FRAME RATE CONTROL ENABLE REGISTER 2 – 0X4F5

Bit	R/W	Default	Description
7:0	RW	0xFF	FRSC_CH_EN[15:8]: Control live channel 15 - 8

FRAME RATE CONTROL ENABLE REGISTER 3 – 0X4F6

Bit	R/W	Default	Description
7:0	RW	0xFF	FRSC_CH_EN[23:16]: Control PB channel 7 - 0

FRAME RATE CONTROL ENABLE REGISTER 4 – 0X4F7

Bit	R/W	Default	Description
7:0	RW	0xFF	FRSC_CH_EN[31:24]: Control PB channel 15 - 8

RED COLOR FOR NO VIDEO CHANNEL – 0X4F8

Bit	R/W	Default	Description
7:0	RW	0	NOVID_R This color will show up when the channel boundary is enable, but channel has no video.

GREEN COLOR FOR NO VIDEO CHANNEL – 0X4F9

Bit	R/W	Default	Description
7:0	RW	0	NOVID_G This color will show up when the channel boundary is enable, but channel has no video.

BLUE COLOR FOR NO VIDEO CHANNEL – 0X4FA

Bit	R/W	Default	Description
7:0	RW	0xFF	NOVID_B This color will show up when the channel boundary is enable, but channel has no video.

HORIZONTAL TOTAL REGISTER 1 – 0X500

Bit	R/W	Default	Description
7:0	R/W	0x2F	HTT[7:0] Pixel count of one horizontal line including blanking. This value should minus 1 by real horizontal total. In interlace mode, if down scaler and TV encoder is used, the vclk is set to 108MHz, so HTT will be set to $4 * 1716 - 1 = 6863$

HORIZONTAL TOTAL REGISTER 2 – 0X501

Bit	R/W	Default	Description
7:4	R	-	Reserved
3:0	R/W	0x07	HTT[12:8] Pixel count of one horizontal line including blanking. This value should minus 1 by real horizontal total. In interlace mode, if down scaler and TV encoder is used, the vclk is set to 108MHz, so HTT will be set to $4 * 1716 - 1 = 6863$

VERTICAL TOTAL REGISTER 1 – 0X502

Bit	R/W	Default	Description
7:0	R/W	0x37	VTT[7:0] Line count of one display frame including blanking. This value should minus 1 by real vertical total. In interlace mode, this value is set to lines of odd filed. Even field is this value plus 1.

VERTICAL TOTAL REGISTER 2 – 0X503

Bit	R/W	Default	Description
7:3	R	-	Reserved
2:0	R/W	0x04	VTT[10:8] Line count of one display frame including blanking. This value should minus 1 by real vertical total. In interlace mode, this value is set to lines of odd filed. Even field is this value plus 1.

HORIZONTAL DISPLAY END REGISTER 1 – 0X504

Bit	R/W	Default	Description
7:0	R/W	0x8F	HDE[7:0] Active display pixel count of one horizontal line. This value should minus 1 by real value.

HORIZONTAL DISPLAY END REGISTER 2 – 0X505

Bit	R/W	Default	Description
7	R/W	0	PHSYNC[9]
6:4	R	-	Reserved
3:0	R/W	0x06	HDE[10:8] Active display pixel count of one horizontal line. This value should minus 1 by real value.

VERTICAL DISPLAY END REGISTER 1 – 0X506

Bit	R/W	Default	Description
7:0	R/W	0x19	VDE[7:0] Line count of active display frame. This value should minus 1 by real value. This value is set to active lines in one field.

VERTICAL DISPLAY END REGISTER 2 – 0X507

Bit	R/W	Default	Description
7:3	R	-	Reserved
2:0	R/W	0x04	VDE[10:8] Line count of active display frame. This value should minus 1 by real value. This value is set to active lines in one field.

HORIZONTAL SYNC STARTING POSITION REGISTER – 0X508

Bit	R/W	Default	Description
7:0	R/W	0x30	PHSYNC[8:1] Horizontal sync pulse starting position after HDE (in two pixels increment)

VERTICAL SYNC STARTING POSITION REGISTER – 0X509

Bit	R/W	Default	Description
7:0	R/W	0x02	PVSYNC[7:0] Vertical sync pulse starting position after VDE

HORIZONTAL SYNC WIDTH REGISTER – 0X50A

Bit	R/W	Default	Description
7:0	R/W	0x20	HSPW[7:0] Horizontal sync pulse width

VERTICAL SYNC WIDTH REGISTER – 0X50B

Bit	R/W	Default	Description
7:0	R/W	0x06	VSPW[7:0] Vertical sync pulse width

SBOX0 CONTROL REGISTER – 0X50C

Bit	R/W	Default	Description
7:5	R/W	0x0	Reserved
4	R/W	0x0	Boundary Line enable 0 = disable 1 = enable
3	R/W	0x0	Box plane enable 0 = disable 1 = enable
2	R/W	0x0	Blinking enable 0 = disable 1 = enable
1:0	R/W	0x0	Mixing control 00 = 75% original pixel value / 25% plane (boundary) color mix 01 = 50% original pixel value / 50% plane (boundary) color mix 10 = 25% original pixel value / 75% plane (boundary) color mix 11 = plane (boundary) color

SBOX LINE WIDTH CONTROL REGISTER 1 - 0X511

Bit	R/W	Default	Description
7:6	R/W	0x0	Box3 Vertical line width control 00 = 1 line 01 = 2 line 10 = 3 line 11 = 4 line
5:4	R/W	0x0	Box3 Horizontal line width control 00 = 1 line 01 = 2 line 10 = 3 line 11 = 4 line
3:2	R/W	0x0	Box2 Vertical line width control 00 = 1 line 01 = 2 line 10 = 3 line 11 = 4 line
1:0	R/W	0x0	Box2 Horizontal line width control 00 = 1 line 01 = 2 line 10 = 3 line 11 = 4 line

SBOX LINE WIDTH CONTROL REGISTER 2 - 0X512

Bit	R/W	Default	Description
7:6	R/W	0x0	Box1 Vertical line width control 00 = 1 line 01 = 2 line 10 = 3 line 11 = 4 line
5:4	R/W	0x0	Box1 Horizontal line width control 00 = 1 line 01 = 2 line 10 = 3 line 11 = 4 line
3:2	R/W	0x0	Box0 Horizontal line width control 00 = 1 line 01 = 2 line 10 = 3 line 11 = 4 line
1:0	R/W	0x0	Box0 Horizontal line width control 00 = 1 line 01 = 2 line 10 = 3 line 11 = 4 line

SBOX0 HL CONTROL REGISTER 1 – 0X513

Bit	R/W	Default	Description
7:0	R/W	0x0	Box0 Left Horizontal point SBOX0_HL[7:0], unit is pixel

SBOX0 HL CONTROL REGISTER 2 – 0X514

Bit	R/W	Default	Description
7:3	R	0x0	Reserved
2:0	R/W	0x0	Box0 Left Horizontal point SBOX0_HL[10:8], unit is pixel

SBOX0 HR CONTROL REGISTER 1 – 0X51B

Bit	R/W	Default	Description
7:0	R/W	0x0	Box0 Right Horizontal point SBOX0_HR[7:0], unit is pixel

SBOX0 HR CONTROL REGISTER 2 – 0X51C

Bit	R/W	Default	Description
7:3	R	0x0	Reserved
2:0	R/W	0x0	Box0 Right Horizontal point SBOX0_HR[10:8], unit is pixel

SBOX0 VT CONTROL REGISTER 1 – 0X523

Bit	R/W	Default	Description
7:0	R/W	0x0	Box0 Top Vertical point SBOX0_VT[7:0], unit is line

SBOX0 VT CONTROL REGISTER 2 – 0X524

Bit	R/W	Default	Description
7:3	R	0x0	Reserved
2:0	R/W	0x0	Box0 Top Vertical point SBOX0_VT[10:8], unit is line

SBOX0 VB CONTROL REGISTER 1 – 0X52B

Bit	R/W	Default	Description
7:0	R/W	0x0	Box0 Bottom Vertical point SBOX0_VB[7:0], unit is line

SBOX0 VB CONTROL REGISTER 2 – 0X52C

Bit	R/W	Default	Description
7:3	R	0x0	Reserved
2:0	R/W	0x0	Box0 Bottom Vertical point SBOX0_VB[10:8], unit is line

BOX BOUNDARY COLOR R BYTE – 0X533

Bit	R/W	Default	Description
7:0	R/W	0x0	Color red byte[7:0]

BOX BOUNDARY COLOR G BYTE – 0X534

Bit	R/W	Default	Description
7:0	R/W	0x0	Color green byte[7:0]

BOX BOUNDARY COLOR B BYTE – 0X535

Bit	R/W	Default	Description
7:0	R/W	0x0	Color blue byte[7:0]

BOX PLANE COLOR R BYTE – 0X536

Bit	R/W	Default	Description
7:0	R/W	0x0	Color red byte[7:0]

BOX PLANE COLOR G BYTE – 0X537

Bit	R/W	Default	Description
7:0	R/W	0x0	Color green byte[7:0]

BOX PLANE COLOR B BYTE – 0X538

Bit	R/W	Default	Description
7:0	R/W	0x0	Color blue byte[7:0]

SCREEN BACKGROUND COLOR R BYTE – 0X539

Bit	R/W	Default	Description
7:0	R/W	0x0	Color red byte[7:0]

SCREEN BACKGROUND COLOR G BYTE – 0X53A

Bit	R/W	Default	Description
7:0	R/W	0x0	Color green byte[7:0]

SCREEN BACKGROUND COLOR B BYTE – 0X53B

Bit	R/W	Default	Description
7:0	R/W	0x0	Color blue byte[7:0]

MOUSE0 HORIZONTAL POSITION REGISTER 1 – 0X53C

Bit	R/W	Default	Description
7:0	R/W	0x0	Mouse0 Horizontal position MOUSE0_HPOS[7:0]

MOUSE0 HORIZONTAL POSITION REGISTER 2 – 0X53D

Bit	R/W	Default	Description
7:3	R	0x0	Reserved
2:0	R/W	0x0	Mouse0 Horizontal position MOUSE0_HPOS[10:8]

MOUSE0 VERTICAL POSITION REGISTER 1 – 0X53E

Bit	R/W	Default	Description
7:0	R/W	0x0	Mouse0 Vertical position MOUSE0_VPOS[7:0]

MOUSE0 VERTICAL POSITION REGISTER 2 – 0X53F

Bit	R/W	Default	Description
7:3	R	0x0	Reserved
2:0	R/W	0x0	Mouse0 Vertical position MOUSE0_VPOS[10:8]

MOUSE1 HORIZONTAL POSITION REGISTER 1 – 0X540

Bit	R/W	Default	Description
7:0	R/W	0x0	Mouse0 Horizontal position MOUSE1_HPOS[7:0]

MOUSE1 HORIZONTAL POSITION REGISTER 2 – 0X541

Bit	R/W	Default	Description
7:3	R	0x0	Reserved
2:0	R/W	0x0	Mouse0 Horizontal position MOUSE1_HPOS[10:8]

MOUSE1 VERTICAL POSITION REGISTER 1 – 0X542

Bit	R/W	Default	Description
7:0	R/W	0x0	Mouse0 Vertical position MOUSE1_VPOS[7:0]

MOUSE1 VERTICAL POSITION REGISTER 2 – 0X543

Bit	R/W	Default	Description
7:3	R	0x0	Reserved
2:0	R/W	0x0	Mouse0 Vertical position MOUSE1_VPOS[10:8]

MOUSE CONTROL REGISTER – 0X544

Bit	R/W	Default	Description
7	R	0x0	Reserved
6	R/W	0x0	Mouse1 Enable 0 = disable 1 = enable
5:4	R/W	0x0	Mouse1 Mixing control 00 = 75% original pixel value / 25% mouse color mix 01 = 50% original pixel value / 50% mouse color mix 10 = 25% original pixel value / 75% mouse color mix 11 = mouse color
3	R	0x0	Reserved
2	R/W	0x0	Mouse0 Enable 0 = disable 1 = enable
1:0	R/W	0x0	Mouse0 Mixing control 00 = 75% original pixel value / 25% mouse color mix 01 = 50% original pixel value / 50% mouse color mix 10 = 25% original pixel value / 75% mouse color mix 11 = mouse color

MOUSE BACKGROUND COLOR R BYTE – 0X545

Bit	R/W	Default	Description
7:0	R/W	0x0	Color red byte[7:0]

MOUSE BACKGROUND COLOR G BYTE – 0X546

Bit	R/W	Default	Description
7:0	R/W	0x0	Color green byte[7:0]

MOUSE BACKGROUND COLOR B BYTE – 0X547

Bit	R/W	Default	Description
7:0	R/W	0x0	Color blue byte[7:0]

MOUSE FOREGROUND COLOR R BYTE – 0X548

Bit	R/W	Default	Description
7:0	R/W	0x0	Color red byte[7:0]

MOUSE FOREGROUND COLOR G BYTE – 0X549

Bit	R/W	Default	Description
7:0	R/W	0x0	Color green byte[7:0]

MOUSE FOREGROUND COLOR B BYTE – 0X54A

Bit	R/W	Default	Description
7:0	R/W	0x0	Color blue byte[7:0]

DISPLAY MODE CONTROL REGISTER – 0X54B

Bit	R/W	Default	Description
7	R/W	0x0	DM_MD_SET: Dual monitor motion box enable (motion box, cursor) 1 : dual monitor motion box register set 0 : Main motion box register set
6:3	R	0x0	Reserved
2	R/W	0x0	LCD_YC_SWAP Control luma and chroma position for BT1120 output
1	R/W	0x0	DIS_VIDEO 1: disable video 0: enable video
0	R/W	0x0	DE_INTLACE 0: weave 1: 2D or 3D

MOUSE RAM ADDRESS REGISTER – 0X54C

Bit	R/W	Default	Description
7:0	R/W	0x0	MOUSE_WR_LOC[7:0]

MOUSE RAM DATA REGISTER – 0X54D

Bit	R/W	Default	Description
7:0	R/W	0x0	MOUSE_WR_DATA

MOUSE REGISTER UPDATE ENABLE REGISTER – 0X54E

Bit	R/W	Default	Description
7:4	R/W	0x3	Repeat frame expected value
3	R/W	0x0	Enable
2	R/W	0x1	Disable
1	R/W	0x0	Masking Bit
0	R/W	0x1	MOUSE_REG_UPDATE 0: not update mouse related registers. 1: update mouse related registers Before set mouse position registers, set this bit to 0. After set done, set this bit to 1.

MOUSE RAM WRITE ENABLE REGISTER – 0X54F

Bit	R/W	Default	Description
0	R/W	0x0	MOUSE_WR_EN

MD BOX CONTROL REGISTER 0 – 0X550

Bit	R/W	Default	Description
7	R/W	0x0	MD Box Enable
6	R/W	0x0	MD Box operation mode select 0 = table mode 1 = motion display mode
5	R/W	0x0	Cursor Cell Enable 0 = disable 1 = enable
4	R/W	0x0	Out Boundary Cell Enable 0 = disable 1 = enable
3	R/W	0x0	Masking Plane Enable 0 = disable 1 = enable
2	R/W	0x0	Detection Plane Enable 0 = disable 1 = enable

Bit	R/W	Default	Description
1:0	R/W	0x0	Mixing control 00 = 75% original pixel value / 25% plane (boundary) color mix 01 = 50% original pixel value / 50% plane (boundary) color mix 10 = 25% original pixel value / 75% plane (boundary) color mix 11 = plane (boundary) color

This register is for channel 1. Similar register 0x551 – 0x55F is for channel 2 – channel 16.

MD BOX LINE WIDTH CONTROL REGISTER 0 – 0X560

Bit	R/W	Default	Description
7:6	R/W	0x0	Box1 Vertical line width control 00 = 1 line 01 = 2 line 10 = 3 line 11 = 4 line
5:4	R/W	0x0	Box1 Horizontal line width control 00 = 1 line 01 = 2 line 10 = 3 line 11 = 4 line
3:2	R/W	0x0	Box0 Vertical line width control 00 = 1 line 01 = 2 line 10 = 3 line 11 = 4 line
1:0	R/W	0x0	Box0 Horizontal line width control 00 = 1 line 01 = 2 line 10 = 3 line 11 = 4 line

This register is for box0, 1. Similar register 0x561 – 0x567 is for box 2 – box 16.

MD BOX 0 HORIZONTAL LEFT POSITION REGISTER 1 – 0X568

Bit	R/W	Default	Description
7:0	R/W	0x0	Box 0 Horizontal Left Position MDBOX0_HL[7:0]

MD BOX 0 HORIZONTAL LEFT POSITION REGISTER 2 – 0X569

Bit	R/W	Default	Description
7:3	R	0x0	Reserved
2:0	R/W	0x0	Box 0 Horizontal Left Position MDBOX0_HL[10:8]

This register is for box0. Similar register 0x56A – 0x587 is for box 1 – box 16.

MD BOX 0 VERTICAL TOP POSITION REGISTER 1 – 0X588

Bit	R/W	Default	Description
7:0	R/W	0x0	Box 0 Vertical Top Position MDBOX0_VT[7:0]

MD BOX 0 VERTICAL TOP POSITION REGISTER 2 – 0X589

Bit	R/W	Default	Description
7:3	R	0x0	Reserved
2:0	R/W	0x0	Box 0 Vertical Top Position MDBOX0_VT[10:8]

This register is for box0. Similar register 0x58A – 0x5A7 is for box 1 – box 16.

MD BOX 0 HORIZONTAL SIZE REGISTER 1 – 0X5A8

Bit	R/W	Default	Description
7:0	R/W	0x0	Box 0 Horizontal Size Position MDBOX0_HS[7:0]

MD BOX 0 HORIZONTAL SIZE REGISTER 2 – 0X5A9

Bit	R/W	Default	Description
7:3	R	0x0	Reserved
2:0	R/W	0x0	Box 0 Horizontal Size Position MDBOX0_HS[10:8]

This register is for box0. Similar register 0x5AA – 0x5C7 is for box 2 – box 16.

MD BOX 0 VERTICAL SIZE REGISTER 1 – 0X5C8

Bit	R/W	Default	Description
7:0	R/W	0x0	Box 0 Vertical Size Position MDBOX0_VS[7:0]

MD BOX 0 VERTICAL SIZE REGISTER 2 – 0X5C9

Bit	R/W	Default	Description
7:3	R	0x0	Reserved
2:0	R/W	0x0	Box 0 Vertical Size Position MDBOX0_VS[10:8]

This register is for box0. Similar register 0x5CA – 0x5E7 is for box 2 – box 16.

MD BOX HCELL REGISTER 0 – 0X5E8

Bit	R/W	Default	Description
7:4	R/W	0x0	Box 1 Horizontal Cell Number MDBOX1_HNUM[3:0]
3:0	R/W	0x0	Box 0 Horizontal Cell Number MDBOX0_HNUM[3:0]

This register is for box0. Similar register 0x5E9 – 0x5EF is for box 2 – box 16.

MD BOX VCELL REGISTER 0 – 0X5F0

Bit	R/W	Default	Description
7:4	R/W	0x0	Box 1 Vertical Cell Number MDBOX1_VNUM[3:0]
3:0	R/W	0x0	Box 0 Vertical Cell Number MDBOX0_VNUM[3:0]

This register is for box0, 1. Similar register 0x5F1 – 0x5F7 is for box 2 – box 16.

MD BOX CURSOR HORIZONTAL POSITION REGISTER 0 – 0X5F8

Bit	R/W	Default	Description
7:4	R/W	0x0	Box 1 Horizontal Cursor Position CUR1_HPOS[3:0]
3:0	R/W	0x0	Box 0 Horizontal Cursor Position CUR0_HPOS[3:0]

This register is for box0, 1. Similar register 0x5F8 – 0x5FF is for box 2 – box 16.

HDMI Controller

Introduction

TW2880's HDMI Transmitter Controller supports HDMI 1.2 (High Definition Multimedia Interface) specification. This fully-compliant device provides a simple, low cost method of sending protected digital audio and video data stream to the compatible devices providing end users with a truly all-digital experience. TW2880 HDMI controller is backward compatible with DVI 1.0 which allows TW2880 to connect to any DVI capable display (for example, DTV, PDP, LCD TV or PC monitor).

TW2880's HDMI Transmitter Controller incorporates a flexible audio and video interface. An industry standard S/PDIF input accepts PCM encoded data as well as Dolby Digital, DTS, and other formats capable of being sent over S/PDIF. Four I²S inputs support DVD-Audio.

The controller consists of a transmitting Link block and a PHY block. The Link block supports video, audio input interfaces, I²C interface and DDC interface. The PHY Block is serializer / driver including three data channels and one clock channel. The signals of these channels are output to TMDS link.

- Monitor Detection supported through Hot Plug and Receiver Detection
- Flexible power management

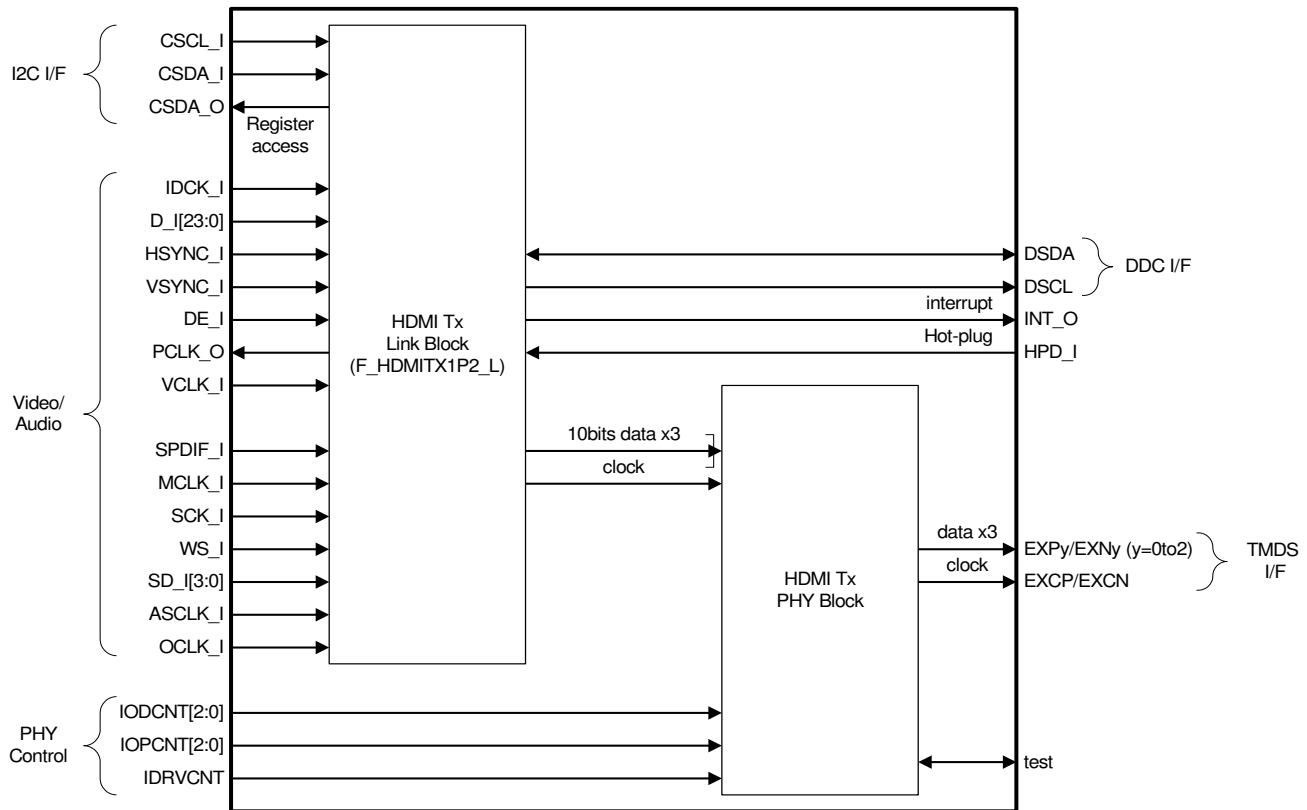
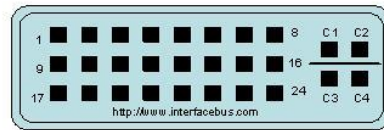

FIGURE 6. HDMI FUNCTIONAL BLOCK DIAGRAM

Physical Port

Two kinds of output connector are supported: DVI and HDMI. DVI uses a 24+4 pin socket and TW2880 can support DVI-D, DVI-I and DVI-A if tapping the output from traditional HD15 VGA analog connector. The pinout is listed below. For HDMI we can support the type A style connector. Both output method support DDC monitor feedback capabilities.



Pin #	Signal Name	Pin #	Signal Name	Pin #	Signal Name
1	TMDS Data2-	9	TMDS Data1-	17	TMDS Data0-
2	TMDS Data2+	10	TMDS Data1+	18	TMDS Data0+
3	TMDS Data2/4 Shield	11	TMDS Data1/3 Shield	19	TMDS Data0/5 Shield
4	TMDS Data4-	12	TMDS Data3-	20	TMDS Data5-
5	TMDS Data4+	13	TMDS Data3+	21	TMDS Data5+
6	DDC Clock [SCL]	14	+5 V Power	22	TMDS Clock Shield
7	DDC Data [SDA]	15	Ground (for +5 V)	23	TMDS Clock +
8	Analog vertical sync	16	Hot Plug Detect	24	TMDS Clock -
C1	Analog Red	--	--	--	--
C2	Analog Green	--	--	--	--
C3	Analog Blue	--	--	--	--
C4	Analog Horizontal Sync	--	--	--	--
C5	Analog GND Return: (analog R, G, B)	--	--	--	--

Control and Configuration

All functions of HDMI Transmitter are controlled and observed by internal I²C registers. TW2880 host interface has an I²C master interface which will translate parallel bus operation into serial I²C operation. If serial interface is chosen as the host interface, The user is actually accessing both TW2880 core and HDMI transmitter using I²C bus. The device addresses are 0x72 for the first device and 0x7A for the second device.

Register addresses range from 0x00 to 0xFF on each page in I²C protocol. Because there are more than 255 bytes of registers in the HDMI Transmitter, the device is accessible at one of two I²C device addresses. All references to device address in this document use the default values of 0x72 and 0x7A.

REGISTERS/CONFIGURATION LOGIC

The register/configuration logic block incorporates all the registers required for configuring and managing this HDMI Transmitter. These registers are used to perform, audio/video format processing, CEA-861B info-packet formatting, and power-down control.

SLAVE I²C INTERFACE

The controller I²C interface on this HDMI Transmitter (ports CSCL_I, CSDA_I and CSDA_O) is a slave interface capable of running up to 400 kHz. This bus is used to configure this HDMI Transmitter by reading/writing to necessary registers.

Audio Data Capture Logic

TW2880 HDMI Transmitter has a high-End digital audio interface which can accept digital audio over S/PDIF, four I²S inputs and eight one-bit audio inputs. 4x I²S inputs accept Dolby Digital, DVD-Audio input (2-channel 192kHz, 8-channel 96kHz). S/PDIF Input supports PCM, Dolby Digital, DTS digital audio transmission (32-192kHz Fs sample rate) IEC60958 or IEC61937 compatible. Flexible, programmable I²S channel mapping. Master I²C interface for DDC connection simplifies board layout and lower cost

S/PDIF

The S/PDIF stream can carry 2-channel uncompressed PCM data (IEC 60958) or a compressed bit stream for multi-channel (IEC 61937) formats. The audio data capture logic forms the audio data into packets in accordance with the HDMI specification. The S/PDIF input supports audio sampling rates from 32 to 192 kHz. A separate master clock input (MCLK), coherent with the S/PDIF input, is required for time-stamping purposes. Coherent means that the MCLK and S/PDIF must have been created from the same clock source. This is typically done by using the original MCLK to strobe out the S/PDIF from the sourcing chip. There is no setup or hold timing requirement on an input with respect to MCLK.

I²S

Four I²S inputs allow transmission of DVD-Audio or decoded Dolby Digital to A/V Receivers and high-end displays. The interface supports up to 8-channel 192 kHz. The I²S ports must also be coherent with MCLK. The audio data can be down-sampled by one half or one-fourth with register control. This allows this HDMI Transmitter to share the audio bus with a high sample rate audio DAC, while down-sampling audio for an attached display which supports only lower rates. Conversions from 192 to 48 kHz, 176.4 to 44.1 kHz, 96 to 48 kHz, and 88.2 to 44.1 kHz are supported. Audio data can only be down-sampled on 2-ch. audio. The appropriate registers must be configured to describe the format of audio being input into this HDMI Transmitter. This information is passed over the HDMI link in the CEA-861B Audio Info (AI) packets. MCLK frequencies support various audio sample rates as shown in Table 18.

TABLE 18. SUPPORTED MCLK FREQUENCIES

Multiple of Fs	Audio Sample Rate, Fs						
	I ² S and S/PDIF Supported Rates						
	32kHz	44.1kHz	48kHz	88.2kHz	96kHz	176.4kHz	192kHz
128	4.096 MHz	5.645 MHz	6.144 MHz	11.29 MHz	12.288 MHz	22.579 MHz	24.576 MHz
192	6.144 MHz	8.467 MHz	9.216 MHz	16.934 MHz	18.432 MHz	33.868 MHz	36.864 MHz
256	8.192 MHz	11.29 MHz	12.288 MHz	22.579 MHz	24.576 MHz	45.158 MHz	49.152 MHz
384	12.288 MHz	16.934 MHz	18.432 MHz	33.864 MHz	36.864 MHz	67.737 MHz	73.728 MHz
512	16.384 MHz	22.579 MHz	24.576 MHz	45.158 MHz	49.152 MHz		
768	24.576 MHz	33.869 MHz	36.864 MHz	67.738 MHz	73.728 MHz		
1024	32.768 MHz	45.158MHz	49.152 MHz				
1152	36.864 MHz	50.803 MHz	55.296 MHz				

TMDS Digital Core

The TMDS digital core performs 8-to-10-bit TMDS encoding on the audio/video/aux data received from the HDMI Link layer. This data is output onto three TMDS differential data lines along with a TMDS differential clock. A resistor tied to the EXT_SWING pin is used to control the TMDS swing amplitude.

DDC Master I²C Interface

This HDMI Transmitter includes a master I²C port for direct connection to the HDMI cable. DDC reads and writes are executed by reading and writing registers in this HDMI Transmitter.

The Master DDC block supports I²C transactions specified by VESA Enhanced Display Data Channel Standard (Section 3.1.2) and supports an I²C write transaction. The Master DDC block complies with the Standard Mode timing of the I²C specification (100 kHz) and supports slave clock stretching as required by EDDC.

Current Read



Sequential Read



Enhanced DDC Read

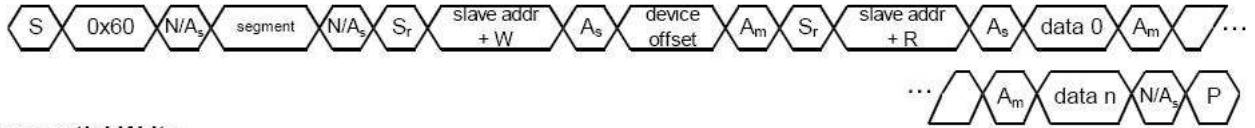

Sequential Write

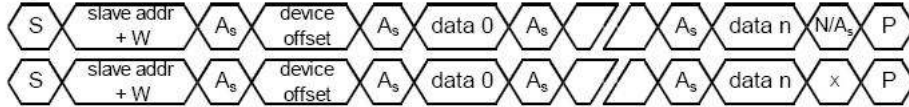

- S = start
- S_r = restart
- A_s = slave acknowledge
- A_m = master acknowledge
- N = no ack
- P = stop

Supported Master I²C Transactions

Register Grouping

The registers in this document are described in groups according to their function. Certain registers in each address range are reserved for future use. The reserved registers have no detailed definitions in this document. Register addresses that are not described in this document should not be written. Modifications to undocumented registers may cause unintended errors in the chip function. Register bits marked as reserved should be written as zeros and will be read as zeros unless otherwise noted.

TABLE 19 REGISTER ADDRESS GROUPS

I ² C Address	Address Range	Group Name	Purpose	Section
0x72	0x00-0x0E	Base	Device identification and general programming.	188
	0x0F-0x31	Reserved	Reserved	Reserved
	0x32-0x6F	Video	DE, Sync Decoder and Encoder.	191
	0x70-0x7F	Interrupt	Interrupt processing.	199
	0xEC-0xFF	DDC	Mastering DDC Bus.	205
	0xF8-0xFF	Reserved	Reserved	207
0x7A	0x00-0x3D	Audio	Audio features and translations.	208
	0x3E-0xFE	CEA-861B	Support for InfoFrame Packets.	216

Usages and Conventions

Bit N	Bits are numbered in little-endian format: the least-significant bit of a byte or word is referred to as bit 0.
0xNN	Hexadecimal representation of base-16 numbers are represented using C language notation, preceded by 0x.
0bNN	Binary (base-2) numbers are represented using C language notation, preceded by 0b.
NN	Decimal (base-10) numbers are represented using no additional prefixes or suffixes.
	Reserved register bits are shaded in the register description.
RSVD0	A bit in a register which is reserved and read-only, and returns a zero value
RSVD1	A bit in a register which is reserved and read-only, and returns a one value.
RSVDRW	A bit in a register which is reserved and read-write, returning the value written to it. RSVDRW0 implies a default of 0 and RSVDRW1 implies a default of 1. RSVDRW implies a default of 0 unless other specified.
X	A register bit defaulting to X has no defined state after hardware reset.

Base Register Set

VENDOR ID REGISTER

Dev	Addr	Name	7	6	5	4	3	2	1	0
0x72	0x00	VND_IDL	Vendor ID Low Byte							
0x72	0x01	VND_IDH	Vendor ID High Byte							
Bit	Label	R/W	Description							Default
15:0	VND_ID	R	Provides unique vendor identification through I ² C.							0x01(Low) 0x00 (High)

DEVICE ID REGISTER

Dev	Addr	Name	7	6	5	4	3	2	1	0
0x72	0x02	DEV_IDL	Device ID Low Byte							
0x72	0x03	DEV_IDH	Device ID High Byte							
Bit	Label	R/W	Description							Default
15:0	DEV_ID	R	Provides unique device type identification through I ² C.							0x32 (Low) 0x91 (High)

DEVICE REVISION REGISTER

Dev	Addr	Name	7	6	5	4	3	2	1	0
0x72	0x04	DEV_REV	Device Revision Byte							
Bit	Label	R/W	Description							Default
7:0	DEV_REV	R	Allows distinction between revisions of same device.							0x01

SOFTWARE RESET REGISTER

Dev	Addr	Name	7	6	5	4	3	2	1	0
0x72	0x05	SRST	RSVD0						FIFORST	SWRST
Bit	Label	R/W	Description							Default
1	FIFORST	RW	Audio FIFO reset: 0 = Normal operation 1 = Reset (flush) audio FIFO							0
0	SWRST	R/W	Software reset: 0 = Normal Operation 1 = Reset all sections, including audio FIFO, but <i>not</i> writable registers							0

SYSTEM CONTROL REGISTER #1

Dev	Addr	Name	7	6	5	4	3	2	1	0
0x72	0x08	SYS_CTRL1	RSVDRW0	VSYNC	VEN	HEN	RSVDRW0	RSVDRW1	EDGE	PD#
Bit	Label	R/W	Description							Default
6	VSYNC	R	The current status of the VSYNC input pin. Refer to the INTR2 register (0x72:0x72), described on page 199, for an interrupt tied to VSYNC active edge.							X
5	VEN	R/W	VSYNC enable: 0 = Fixed LOW 1 = Follow VSYNC input							1
4	HEN	R/W	HSYNC enable: 0 = Fixed LOW 1 = Follow HSYNC input							1
1	EDGE	R/W	Edge select: 0 = Latch Input on Falling Edge 1 = Latch Input on Rising Edge							0
0	PD#	R/W	Power down mode: HIGH is normal operation. When LOW, TMDS core is powered down and interrupts are in power-down mode. Most other register values are not affected by assertion of the PD# bit. For exceptions, see page .259							0

SYSTEM STATUS REGISTER

Dev	Addr	Name	7	6	5	4	3	2	1	0	
0x72	0x09	SYS_STAT	VLOW	RSVDRW0				RSEN	HPD	P_STABLE	
Bit	Label	R/W	Description							Default	
7	VLOW	R	VREF mode. Always HIGH.							1	
2	RSEN	R	Receiver Sense (works in DC-coupled systems only): 0 = No Receiver connected 1 = Receiver is connected and powered on RSEN is active when the TMDS link is terminated, usually into a powered-on TMDS Receiver chip. An active RSEN implies an active Hot Plug Detect, as the link must also be physically connected.							X	
1	HPD	R	Hot Plug Detect: The state of the Hot Plug Detect pin can be read here.							X	
0	P_STABLE	R	IDCK to TMDS Clock Stable. A change to the IDCK sets this bit LOW. After a subsequent LOW to HIGH transition, indicating a stable input clock, a software reset is recommended.							0	

LEGACY REGISTERS

Dev	Addr	Name	7	6	5	4	3	2	1	0	
0x72	0x0A	SYS_CTRL3	RSVDRW0					CTL SVDO			RSVDRW0
0x72	0x0B	LEGACY1	RSVDRW0								
0x72	0x0E	LEGACY3	RSVDRW0								
Bit	Label	R/W	Description							Default	
2:1	CTL	R/W	The states of these control bits are transmitted across the TMDS link during blanking times for DVI 1.0 mode only.							0b00	

DATA CONTROL REGISTER

Dev	Addr	Name	7	6	5	4	3	2	1	0
0x72	0x0D	DCTL	RSVDRW0			RSVDO		RSVDRW0	AUD_MUTE	Reserved
Bit	Label	R/W	Description							Default
1	AUD_MUTE	R/W	0 = Do not send zeros in audio packet 1 = Send zeros in audio packet							0

Automatic Ri Check

The auto-synchronous Ri check compares the HDMI Transmitter's Ri value to the HDMI Receiver's Ri' value on the 0 and 127th frame. When reading the HDMI Receiver's Ri' value, the automatic Ri check uses the DDC output port. Use bit 0 in the RI_STAT register (0x72.0x26), described below, for proper handshaking between the automatic Ri check and the Master DDC functionality. The automatic Ri check can also be enabled or disabled (it is disabled by default). Interrupts can be configured to trigger on an HDMI Transmitter Ri and Receiver Ri' mismatch condition.

RI STATUS REGISTER

Dev	Addr	Name	7	6	5	4	3	2	1	0
0x72	0x26	RI_STAT	RSVDO							Ri_Started
Bit	Label	R/W	Description							Default
0	Ri_Started	R	Ri check started status. This signal is used for handshaking between the firmware and the hardware. After the Ri check is enabled, the hardware waits for the DDC master to finish the current transaction before taking control. After this bit is set, the firmware loses the ability to use the DDC Master, unless it disables Ri Check and this bit resets to 0.							0

RI COMMAND REGISTER

Dev	Addr	Name	7	6	5	4	3	2	1	0
0x72	0x27	RI_Cmd	RSVDRW0							Ri_En
Bit	Label	R/W	Description							Default
0	Ri_En	R/W	Enable Ri check. Check bit 0 of the Ri_STAT register (0x72:0x26) for firmware and hardware DDC control handshaking. 1 = Enabled 0 = Disabled							0

RI LINE START REGISTER

Dev	Addr	Name	7	6	5	4	3	2	1	0
0x72	0x28	RI_START	Ri_Line_Start							
Bit	Label	R/W	Description							Default
7:0	Ri_Line_Start	R/W	Indicates at what line within frame 127 or 0 to start the Ri Check. 2 LSB are 0.							0x04

RI FROM RX REGISTER

Dev	Addr	Name	7	6	5	4	3	2	1	0
0x72	0x29	RI_RX_L	Ri_RX[7:0]							
0x72	0x2A	RI_RX_H	Ri_RX[15:8]							
Bit	Label	R/W	Description							Default
15:0	Ri_RX	R	This value represents the HDMI Receiver's Ri value if any of the Ri Check errors occurred.							0

DE Generator Register Set

The HDMI Transmitter provides an internal Data Enable (DE) generator for use when the attached video source does not provide a DE signal with the other video signals. The DE signal is needed for encoding the TMDS output of the HDMI Transmitter. A DE signal is generated for use by the Transmitter, based on the values in the DE Generator registers and the arrival times of the HSYNC and VSYNC pulses from the video source. This DE signal is included in the control data sent to the HDMI Receiver across the link. The DE Generator registers are used only for DE generation. The registers are shown diagrammatically in Figure 7. The vertical sync pulse (VSYNC) occurs in the top area of the frame, before the active video area. The active (leading) edge is shown with an arrow. The horizontal sync pulse (HSYNC) occurs every line before the active video area during the DE_DLY time. The active (leading) edge of HSYNC is shown with an arrow.

Note: The VSYNC and HSYNC widths are not shown to scale.

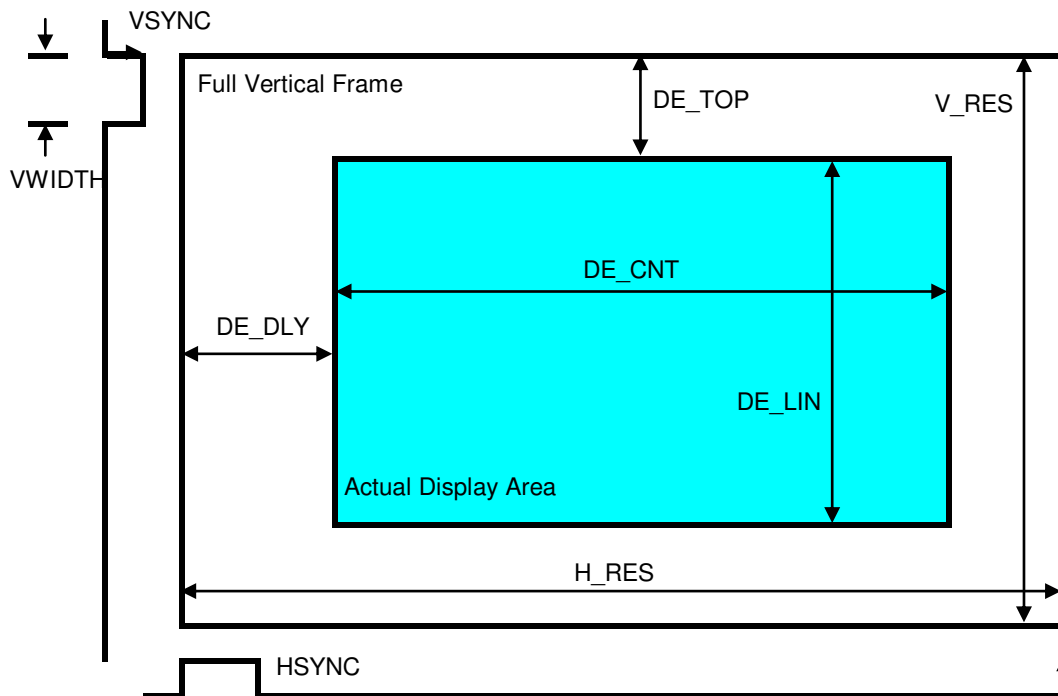

FIGURE 7. DE GENERATOR MEASUREMENTS

In the following definitions, *pixels* mean unique pixels. The counts in the DE Generator registers, if expressed in pixels, are counted according to the original input clock even if that original input clock is multiplied within the chip. For example, a 480i field contains 720 unique pixels per line in the active video area even when the clock is multiplied to 1440 clock cycles per active video time.

Register 0x72:0x3F records the detected polarity of VSYNC and HSYNC. The output polarities are set by register 0x72:0x33.

Note: When using the Sync Decoding module (see page 195), the DE input signal should be tied LOW.

VIDEO DE DELAY REGISTER

Dev	Addr	Name	7	6	5	4	3	2	1	0
0x72	0x32	DE_DLY	DE_DLY[7:0]							
Bit	Label	R/W	Description							Default
7:0	DE_DLY[7:0]	R/W	Width of the area to the left of the active display. The unit of measure is pixels. This register should be set to the sum of (HSYNC width) + (horizontal back porch) + (horizontal left border), and is used only for DE generation. Note: This 12-bit value includes two bits from register 0x72:0x33. The valid range is 1-4095. 0 is invalid.							0x00

VIDEO DE CONTROL REGISTER

Dev	Addr	Name	7	6	5	4	3	2	1	0
0x72	0x33	DE_CTRL	RSVD0	DE_GEN	VS_POL#	HS_POL#	DE_DLY[11:8]			
Bit	Label	R/W	Description							Default
6	DE_GEN	R/W	Generate DE signal: 0 = Disabled 1 = Enabled							0
5	VS_POL#	R/W	VSYNC polarity: 0 = Positive polarity (leading edge rises). 1 = Negative polarity (leading edge falls). This bit should be set to the input VSYNC polarity for the source that provides VSYNC. For embedded syncs, this bit should be set to the desired VSYNC polarity that is generated from the embedded sync codes.							0
4	HS_POL#	R/W	HSYNC polarity: 0 = Positive polarity (leading edge rises). 1 = Negative polarity (leading edge falls). This bit should be set to the input HSYNC polarity for the source that provides HSYNC. For embedded syncs, this bit should be set to the desired HSYNC polarity that is generated from the embedded sync codes.							0
3:0	DE_DLY[11:8]	R/W	Bits 11:8 of the DE_DLY value (see register 0x72:0x32).							0b0000

Note: If both DE signal generation and sync decoding are enabled, VS_POL# and HS_POL# define the polarities of VSYNC and HSYNC from the sync decoder. The DE Generator may be used in combination with sync decoding because the encoded syncs do not carry polarity information. To set the transmitted HSYNC and VSYNC to HDMI-compliant states, the DE Generator may be needed. See the VID_MODE register (0x72:0x4A), described on page 198 and the diagram on 198.

VIDEO DE TOP REGISTER

Dev	Addr	Name	7	6	5	4	3	2	1	0
0x72	0x34	DE_TOP	RSVD0	DE_TOP						
Bit	Label	R/W	Description							Default
6:0	DE_TOP	R/W	Defines the height of the area above the active display. The unit of measure is lines (HSYNC pulses). This register should be set to the sum of (VSYNC width) + (vertical back porch) + (vertical top border). The valid range is 1-127. 0 is invalid.							0b0000000

VIDEO DE COUNT REGISTER

Dev	Addr	Name	7	6	5	4	3	2	1	0
0x72	0x36	DE_CNTL	DE_CNTL[7:0]							
0x72	0x37	DE_CNTH	RSVD0				DE_CNTH[11:8]			
Bit	Label	R/W	Description							Default
11:0	DE_CNT	R/W	Defines the width of the active display. The unit of measure is pixels. This register should be set to the desired horizontal resolution. The valid range is 1-4095. 0 is invalid.							0

Note: Values measured in pixels (DE_CNT, and so on) count the total number of unique pixels on a line. If the input clock is a multiple of the pixel rate (see the DEMUX bit, described on page 198 and the ICLK bit, described on page 197), the registers indicate pixel count, which is not the same as clock count.

VIDEO DE LINE REGISTER

Dev	Addr	Name	7	6	5	4	3	2	1	0		
0x72	0x38	DE_LINL	DE_LIN[7:0]									
0x72	0x39	DE_LINH	RSVDO					DE_LIN[10:8]				
Bit	Label	R/W	Description								Default	
10:0	DE_LIN	R/W	Defines the height of the active display. The unit of measure is lines (HSYNC pulses). This register should be set to the desired vertical resolution. For interlaced modes, this register should be programmed to the number of lines per field, which is half the overall vertical resolution. The valid range is 1-2047. 0 is invalid.								0	

VIDEO H RESOLUTION REGISTER

Dev	Addr	Name	7	6	5	4	3	2	1	0		
0x72	0x3A	HRES_L	H_RES[7:0]									
0x72	0x3B	HRES_H	RSVDO					H_RES[12:8]				
Bit	Label	R/W	Description								Default	
12:0	H_RES	R	Measures the time between two HSYNC active edges. The unit of measure is pixels.								0	

VIDEO V REFRESH REGISTER

Dev	Addr	Name	7	6	5	4	3	2	1	0		
0x72	0x3C	VRES_L	V_RES[7:0]									
0x72	0x3D	VRES_H	RSVDO					V_RES[10:8]				
Bit	Label	R/W	Description								Default	
10:0	V_RES	R	Measures the time between two VSYNC active edges. The unit of measure is lines.								0	

The values in the DE Generator read-only registers are maintained until input HSYNC and VSYNC pulses are stopped. If an input IDCK continues, the DE Generator counters overflow and the registers store zero until HSYNC and VSYNC are active again. The values in these registers are accurate only when there are active HSYNC and VSYNC inputs, or active SAV/EAV sequences (for embedded sync input).

Video Embedded Sync Decoding Registers

When decoding syncs from the embedded sync stream (see register 0x72:0x4A, on page 198), the DE Generator block should be disabled (see register 0x72:0x33[6], on page 193). Also, the DE input signal should be tied LOW.

See the diagram on page 229 and the explanation for handling interlaced video on page 231.

VIDEO INTERFACE ADJUSTMENT REGISTER

Dev	Addr	Name	7	6	5	4	3	2	1	0
0x72	0x3E	IADJUST	RSVD0					DE_ADJ#	F2VADJ	F2VOFST
Bit	Label	R/W	Description							Default
2	DE_ADJ#	R/W	0 = Enable VSYNC 1 = Disable VSYNC Setting this bit HIGH disables VSYNC adjustments and sets the DE generator to be more compatible with the existing Transmitters. Clearing this bit enables detection circuits to locate the position of VSYNC relative to HSYNC and only include HSYNC edges that are greater than 3/4 lines from VSYNC in the line count for DE_TOP.							1
1	F2VADJ	R/W	If this bit is set, the VBIT_TO_VSYNC value (register 0x72:0x46) is adjusted during field 2 of an interlace frame according to the setting of the F2VOFST bit. This bit defaults to 0.							0
0	F2VOFST	R/W	0 = If F2VADJ and this bit are cleared, VBIT_TO_VSYNC (register 0x72:0x46) is decremented by one during field 2 of an interlace frame. 1 = If F2VADJ and this bit are set, VBIT_TO_VSYNC is incremented by one during field 2 of an interlace frame.							0

VIDEO SYNC POLARITY DETECTION REGISTER

Dev	Addr	Name	7	6	5	4	3	2	1	0
0x72	0x3F	POL_DETECT	RSVD0					I_DET	VPOL_DET#	HPOL_DET#
Bit	Label	R/W	Description							Default
2	I_DET	R	Interlace detect: 0 = Non-interlaced video 1 = Interlaced video This bit is set by checking for a varying VSYNC timing characteristic of interlaced modes.							0
1	VPOL_DET#	R	Detected input VSYNC polarity, using internal circuit: 0 = Active high (leading edge rises) 1 = Active low (leading edge falls) Note: The polarity of VPOL_DET# is opposite the polarity of the detect bits in the receiver.							1
0	HPOL_DET#	R	Detected input HSYNC polarity, using internal circuit: 0 = Active HIGH (leading edge rises) 1 = Active LOW (leading edge falls) Note: The polarity of HPOL_DET# is opposite the polarity of the detect bits in the receiver.							1

VIDEO HBIT TO HSYNC REGISTER

Dev	Addr	Name	7	6	5	4	3	2	1	0	
0x72	0x40	HBIT_2HSYNC1	HBIT_TO_HSYNC[7:0]								
0x72	0x41	HBIT_2HSYNC2	RSVD0						[9:8]		
Bit	Label	R/W	Description							Default	
9:0	HBIT_TO_HSYNC	R/W	Creates HSYNC pulses. Set this register to the delay from the detection of an EAV sequence (H bit change from 1 to 0) to the active edge of HSYNC. The unit of measure is pixels. The valid range is 1-1023. 0 is invalid.							0	

Note: Registers 0x72:0x40 and 0x72:0x41 are useful only when the input video uses 656 encoded syncs.

VIDEO FIELD2 HSYNC OFFSET REGISTER

Dev	Addr	Name	7	6	5	4	3	2	1	0	
0x72	0x42	FLD2_HS_OFSTL	FIELD2_OFST[7:0]								
0x72	0x43	FLD2_HS_OFSTH	RSVD0				FIELD2_OFST[11:8]				
Bit	Label	R/W	Description							Default	
11:0	FIELD2_OFST	R/W	Determines VSYNC pixel offset for the odd field of an interlaced source. Set this to half the number of pixels/line. The valid range is 1-4095. 0 is invalid.							0	

VIDEO HSYNC LENGTH REGISTER

Dev	Addr	Name	7	6	5	4	3	2	1	0	
0x72	0x44	HWIDTH1	HWIDTH[7:0]								
0x72	0x45	HWIDTH2	RSVD0						[9:8]		
Bit	Label	R/W	Description							Default	
9:0	HWIDTH	R/W	Sets the width of the HSYNC pulses. Set this register to the desired HSYNC pulse width. The unit of measure is pixels. The valid range is 1-1023. 0 is invalid.							0	

VIDEO VBIT TO VSYNC REGISTER

Dev	Addr	Name	7	6	5	4	3	2	1	0
0x72	0x46	VBIT_TO_VSYNC	RSVD0		VBIT_TO_VSYNC					
Bit	Label	R/W	Description							Default
5:0	VBIT_TO_VSYNC	R/W	Sets the delay from the detection of V bit changing from 1 to 0 in an EAV sequence, to the asserting edge of VSYNC. The unit of measure is lines. The valid range is 1-63. 0 is invalid.							0b000000

Note: Registers 0x72:0x42-0x46 are useful only when the input video uses 656 encoded syncs.

VIDEO VSYNC LENGTH REGISTER

Dev	Addr	Name	7	6	5	4	3	2	1	0
0x72	0x47	VWIDTH	RSVD0		VWIDTH					
Bit	Label	R/W	Description							Default
5:0	VWIDTH	R/W	Sets the width of VSYNC pulse. The unit of measure is lines. The valid range is 1-63. 0 is invalid.							0b000000

Figure 7 shows the HWIDTH and VWIDTH dimensions relative to the complete frame time.

VIDEO CONTROL REGISTER

Dev	Addr	Name	7	6	5	4	3	2	1	0
0x72	0x48	VID_CTRL	IFPOL	RSVDRW	EXTN	CSCSEL	RSVD0	ICLK		
Bit	Label	R/W	Description							Default
7	IFPOL	R/W	Invert field polarity: 0 = Do not invert field bit 1 = Invert field bit This bit is used when the 656 Flag bit is opposite the standard polarity for Field1 and Field2. Inverting the field polarity causes the sync extraction to format HSYNC and VSYNC properly based on the F bit. In embedded sync mode, the HDMI Transmitter does not detect <i>even</i> from <i>odd</i> field, except based on the setting of the F bit. With explicit syncs, the HDMI Transmitter encodes HSYNC and VSYNC across the HDMI/TMDS link regardless of field sequence.							0
6	RSVDRW	R/W	Do not write this bit to 1.							0
5	EXTN	R/W	Extended Bit mode: 0 = All 8-bit input modes 1 = All 12-bit 4:2:2 input modes For 4:2:2 inputs wider than 8 bits but less than 12 bits, the unused bits should be set to 0.							0
4	CSCSEL	R/W	Color Space Conversion Standard select: 0 = BT.601 conversion 1 = BT.709 conversion							0
1:0	ICLK	R/W	Clock mode: 0b00 = Pixel data is not replicated 0b01 = Pixels are replicated once (each sent twice) 0b10 = RSVD 0b11 = Pixels are replicated 4 times (each sent four times) Refer to page 233. for examples of coding ICLK and the related field TCLKSEL for various video+audio modes. Note: If the DEMUX bit (0x72:0x4A[1]) is set to 0, the value of ICLK must be the same as the value for the pixel replication field of AVI v2 data byte 5. If the DEMUX bit is set to 1, the value of ICLK must be the next highest entry.							0b00

VIDEO MODE REGISTER

Dev	Addr	Name	7	6	5	4	3	2	1	0
0x72	0x4A	VID_MODE	RSVDRW0		DITHER	RANGE	CSC	UPSMP	DEMUX	SYNCEXT
Bit	Label	R/W	Description							Default
5	DITHER	R/W	0 = Dither disabled; the video output is truncated to the output width specified in DITHER_MODE [7:6] 1 = Dither enabled; the video output is dithered to the output width specified in DITHER_MODE [7:6]							0
4	RANGE	R/W	Data Range 16-to-235 to 0-to-255 expansion: 0 = Disabled 1 = Enabled When this bit is set, the HDMI Transmitter expands the range of pixel data values from 16-235 into the full 8-bit range of 0-255. This is suitable for translating input YCbCr data into output RGB data in PC modes that use the complete range. The HDMI 1.0 Specification allows one non-CEA-861B mode in the first and only 18-byte descriptor of the Sink's EDID 1.3. This is the native resolution of the Sink, which may be RGB. It may be a standard PC resolution (XGA, SXGA, WXGA, and so on), or a specific native resolution. In these cases (or for a Sink with the Type B HDMI connector, which allows multiple PC modes), when the HDMI Transmitter receives YCbCr data, the data must be expanded to full range for outputting RGB full-range modes. See the HDMI 1.0 Specification, Sections 4.1.2.1 and 4.1.2.2.							0
3	CSC	R/W	YCbCr to RGB Color Space Conversion: 0 = Disabled 1 = Enabled							0
2	UPSMP	R/W	Up sampling 4:2:2 to 4:4:4: 0 = Disabled 1 = Enabled							0
1	DEMUX	R/W	One- to Two-Data-Channel Demux: 0 = Disabled 1 = Enabled							0
0	SYNCEXT	R/W	Embedded Sync Extraction: 0 = Disabled 1 = Enabled							0

Interrupt Registers

The interrupt registers are used to coordinate enabling and recognition of a variety of interrupts with the HDMI Transmitter.

INTERRUPT STATE REGISTER

Dev	Addr	Name	7	6	5	4	3	2	1	0	
0x72	0x70	INTR_STATE	RSVDO							INTR	
Bit	Label	R/W	Description							Default	
0	INTR	R	Interrupt State. When an interrupt is asserted, this bit is set to 1. The polarity of the INT output signal is set using this bit and the POLARITY# bit in the INT_CTRL register (0x72:0x79). Only INTR1, INTR2, and INTR3 bits with matching set bits in INT_UNMASK can contribute to setting the INTR bit.							0	

INTERRUPT SOURCE REGISTER

Dev	Addr	Name	7	6	5	4	3	2	1	0
0x72	0x71	INTR1	SOFT	HPD	RSEN	DROP_SAMP LE	BI_PHASE_ ERR	RI_128	OVER_ RUN	UNDER_ RUN
0x72	0x72	INTR2	RSVDO	SPDIF_ PAR	ENC_ DIS	PREAM_ ERR	CTS_CHG	ACR_OVR	TCLK_ STBL	VSYNC_ REC
0x72	0x73	INTR3	RI ERR #3	RI ERR #2	RI ERR #1	RI ERR #0	DDC Cmd Done	DDC FIFO Half	DDC FIFO Full	DDC FIFO Empty
Bit	Label	R/W	Description							Default

INTR1

7	SOFT	R	Software Induced Interrupt - allows the firmware to generate an interrupt directly.	0
6	HPD	R	Monitor Detect Interrupt - asserted if Hot Plug Detect has changed state. The HDMI Transmitter signals a change in the connectivity to a Sink, either unplug or plug. HDMI specifies that Hot Plug be active only when the Sink's EDID is ready to be read and that Hot Plug be toggled any time there is a change in connectivity downstream of an attached Repeater.	0
5	RSEN	R	Receiver Sense Interrupt asserted if RSEN has changed. This interrupt is set whenever VCC is applied to, or removed from, the attached HDMI Receiver chip. A Receiver with multiple input ports can also disconnect the TMDS termination to the unused port, which triggers this RSEN interrupt.	0
4	DROP_SAMPLE	R	New preamble forced to drop sample (S/PDIF input only). If the HDMI Transmitter detects an 8-bit preamble in the S/PDIF input stream before the sub-frame has been captured, this interrupt is set. A S/PDIF input that stops signaling or a flat line condition can create such a premature preamble.	0
3	BIP_HASE_ERR	R	Input S/PDIF stream has bi-phase error. This can occur when there is noise or an Fs rate change on the S/PDIF input.	0
2	RI_128	R	Input counted past frame count threshold set in RI_128_COMP register. This interrupt occurs when the count written to register 0x72:0x24 is matched by the VSYNC (frame) counter in the HDMI Transmitter. It should trigger the firmware to perform a link integrity check. Such a match occurs every 128 frames.	0

Dev	Addr	Name	7	6	5	4	3	2	1	0
1	OVER_RUN		R	Audio FIFO Overflow. This interrupt occurs if the audio FIFO overflows when more samples are written into it than are drawn out across the HDMI link. Such a condition can occur from a transient change in the Fs or pixel clock rate.						0
0	UNDER_RUN		R	Audio FIFO Underflow. Similar to OVER_RUN. This interrupt occurs when the audio FIFO empties.						0

INTR2

6	SPDIF_PAR		R	S/PDIF Parity Error. The S/PDIF stream includes a parity (P) bit at the end of each sub frame. An interrupt occurs if the calculated parity does not match the state of this bit.						0
5	ENC_DIS		R	The ENC_EN bit (0x72:0x0F[0]) changed from 1 to 0. This interrupt occurs if encryption is turned off.						0
4	PREAM_ERR		R	The condition is the opposite of the condition that causes DROP_SAMPLE (0x72:0x71[4]). This interrupt occurs if a preamble is expected but not found when decoding the S/PDIF stream.						0
3	CTS_CHG		R	Change In ACR CTS Value. This interrupt occurs when the change is of an unexpected magnitude. Such an interrupt should be expected when changing Fs or pixel clock frequency.						0
2	ACR_OVR		R	ACR Packet Overwrite. This interrupt occurs if the HDMI Transmitter puts a NCTS packet into the queue before the previous NCTS packet has been sent. This can happen if very long active data times do not allow for sufficient NCTS packet bandwidth. For all CEA-861B modes, no ACR_OVR interrupt should occur.						0
1	TCLK_STBL		R	TCLK_STABLE (register 0x72:0x09[0]) changes state. Whenever IDCK changes, there is a temporary instability in the internal clocking. This interrupt is set when the internal clocking has stabilized.						0
0	VSYNC_REC		R	Asserted when VSYNC active edge is recognized. It is useful for triggering firmware actions that occur during vertical blanking.						0

INTR3

7	Ri Err #3		R	Ri not read within one frame.						0
6	Ri Err #2		R	Ri did not change between frame #127 and #0.						0
5	Ri Err #1		R	Ri and Ri' do not match during frame #0 (ICNT)						0
4	Ri Err #0		R	Ri and Ri' do not match during frame #127 (ICNT-1)						0
3	DCC Cmd Done		R	DDC command is complete.						0
2	DDC FIFO Half		R	DDC FIFO is half full.						0
1	DDC FIFO Full		R	DDC FIFO is full.						0
0	DDC FIFO Empty		R	DDC FIFO is empty.						1

7:0	For each interrupt bit...	R	1 = Interrupt asserted 0 = No interrupt occurred						
7:0		W	Write any bit to 1 to clear the bit and the interrupt						

When the device is powered-down (PD#=0) the INT output pin is driven with RSEN. No other condition generates an interrupt when the HDMI Transmitter is powered-down with PD#. The Source device must use other means to monitor the hot plug state, if necessary, such as polling the System Status Register (see page 189). The RSEN interrupt bit is set *only* when the HDMI Receiver sense changes from 0 to 1, *not* on a change from 1 to 0.

INTERRUPT UNMASK REGISTER

Interrupts are set in the INTR1, INTR2, and INTR3 registers as they occur, but only those interrupts with a corresponding set bit in INT_UNMASK1 through INT_UNMASK3 are also logically ORed into the INT output pin signal. The state of all interrupts can be checked at any time by reading the INTR1, INTR2, and INTR3 registers directly.

All bits marked RSVD in the interrupt registers should have the corresponding bit in the INT_UNMASK register cleared to zero.

Dev	Addr	Name	7	6	5	4	3	2	1	0
0x72	0x75	INT_UNMASK1								
0x72	0x76	INT_UNMASK2								
0x72	0x77	INT_UNMASK3								
Bit	Label	R/W	Description							Default
23:0	INT_UNMASK	R/W	Each bit corresponds to one bit in INTR1, INTR2, or INTR3: 0 = Disable corresponding interrupt from INT output 1 = Enable corresponding interrupt to INT output							0

INTERRUPT CONTROL REGISTER

Dev	Addr	Name	7	6	5	4	3	2	1	0
0x72	0x79	INT_CTRL	RSVDRO			SOFT_INTR		RSVDRWO	POLARITY#	RSVDRO
Bit	Label	R/W	Description							Default
3	SOFT_INTR	R/W	Set software interrupt: 0 = Clear interrupt 1 = Set interrupt							0
1	POLARITY#	R/W	INT pin assertion level: 0 = Assert HIGH 1 = Assert LOW							1

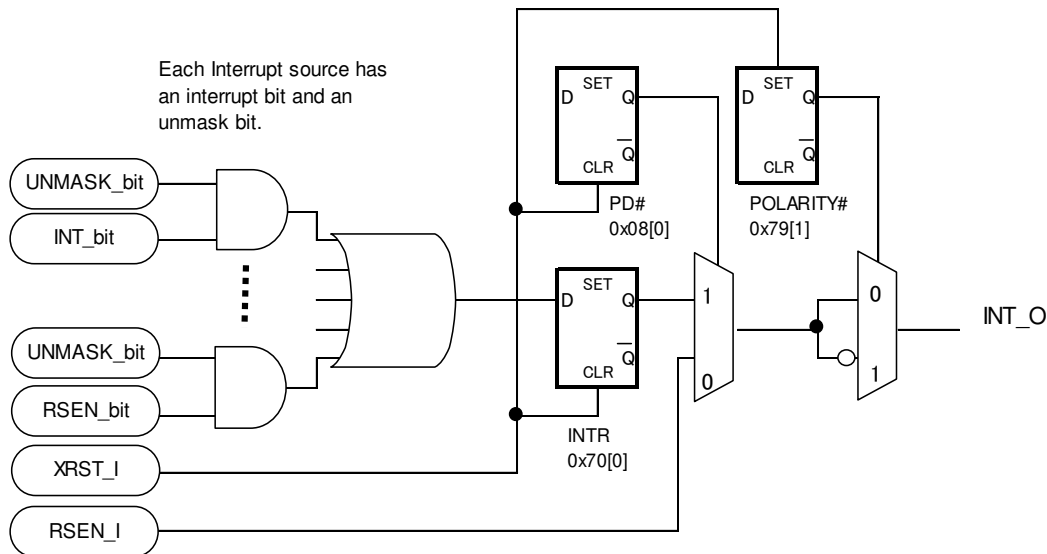

FIGURE 8. INTERRUPT PIN CONTROL

The representation in Figure 8 shows the control of the INT output pin. Each interrupt source has a bit (shown as INT_bit) and an unmask (shown as UNMASK_bit). These are logically ANDed, then ORed, and latched with the active output clock. During RESET#=LOW, PD# is reset to zero. In power-down mode (PD# asserted), the active level from the HDMI Receiver sense logic (RSEN) is output as the INT signal. The POLARITY# control affects INT in all modes. RESET#=LOW loads PD#=0 and POLARITY#=1 as a default. Therefore, the INT output will be driven LOW when a powered-on TMDS Receiver is attached (RSEN=1).

TMDS Control Register Set

The TMDS registers control TMDS (Transition-Minimized Differential Signaling).

TMDS CONTROL REGISTER

Dev	Addr	Name	7	6	5	4	3	2	1	0
0x72	0x82	TMDS_CTRL	RSVDRW0	TCLKSEL		RSVDRW0				
Bit	Label	R/W	Description							Default
6:5	TCLKSEL	R/W	Selects FPLL multiple of the IDCK: 0b00 = FPLL is 0.5*IDCK 0b01 = FPLL is 1.0*IDCK 0b10 = FPLL is 2.0*IDCK 0b11 = FPLL is 4.0*IDCK							01

For certain combinations of video input clock frequency and audio sampling rate, it is necessary for the HDMI Transmitter to use a higher multiple of the input pixel clock when sampling the S/PDIF input.

You must set ICLK to reflect the pixel replication factor of the input data stream so that it is properly decoded. TCLKSEL indicates the factor by which the input clock (IDCK) must be multiplied to yield the output clock frequency. These settings ensure that the output clock can provide sufficient bandwidth for multi-channel audio data on an HDMI link (25MHz at a minimum). The pixel replication count bits in the AVI InfoFrame Packet must be accurate.

480p mode (pixel clock = 27MHz)							
Input Clock (IDCK) ¹	Audio Mode & max f _s	ICLK 0x48[1:0] Input Pixel Replication ⁴	DEMUX 0x4A[1]	TCLKSEL ³ 0x82[6:5]	Output (Link) Clock ¹	Output Pixel Replication ¹⁰	AVI InfoFrame Packet Byte 5bits PR3:PR0 ¹⁰
54MHz	8ch, 96kHz	0b01 (2x)	0	0b01 (1.0)	54MHz ⁶	2x ⁷	0b0001
54MHz	2ch, 192kHz	0b01 (2x)	0	0b00 (0.5)	27MHz	1x	0b0000
54MHz	8ch, 96kHz	0b00 (1x)	1 ⁵	0b01	54MHz ⁶	2x ⁷	0b0001
54MHz	2ch, 192kHz	0b00 (1x)	1 ⁵	0b00	27MHz	1x	0b0000
27MHz	8ch, 96kHz	0b00 (1x)	0	0b10 (2.0)	54MHz ⁶	2x ⁷	0b0001
27MHz	2ch, 192kHz	0b00 (1x)	0	0b11 (4.0)	108MHz	4x ⁸	0b0011
27MHz	8ch, 48kHz	0b00 (1x)	0	0b01	27MHz	1x ⁹	0b0000

NOTES:

Input Clock (IDCK) and Output Clock must be within the min/max range for the HDMI Transmitter.

For proper decoding, you must set ICLK to reflect the pixel replication factor of the input data stream.

Factor by which input clock must be multiplied to give output clock frequency.

There is only one pixel per 27 MHz clock cycle, so each must be replicated.

When YCbCr 4:2:2 data is multiplexed onto a single channel, the input clock must be doubled.

54 MHz is necessary so the blanking intervals have sufficient bandwidth to carry the 8-channel audio data sampled at frequencies up to 96 kHz.

Because the output clock has been doubled, pixels must be replicated.

Illustrates 4x pixel replication on output.

27 MHz input clock provides sufficient bandwidth for 8-channel audio data sampled at frequencies 48 kHz and below. Refer to the *HDMI Specification*.

Bits PR0:PR3 of Byte 5 of the AVI InfoFrame packet indicate to the HDMI Sink how many repetitions of each unique pixel are transmitted. Refer to Table 14 in the *CEA-861B Specification*.

These settings ensure that the output clock provides sufficient bandwidth for multi-channel audio data on a HDMI link (25MHz minimum).

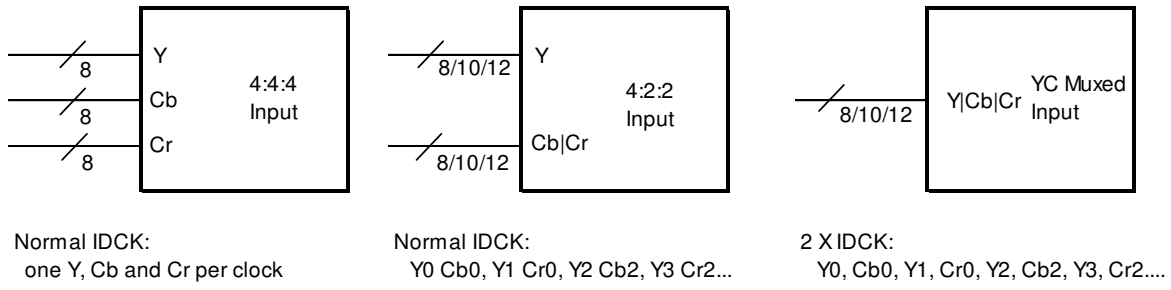

FIGURE 9. INPUT BUS DIAGRAM FOR DIFFERENT FORMATS

Note: All three input bus formats can use 656 encoded syncs.

DDC Master Registers

The following registers control the DDC output port. A description of this feature begins on page 255. The speed of the Master DDC clock is determined by an internal oscillator in the HDMI Transmitter, with a maximum of 100kbps. There is no requirement for an active input pixel clock to the HDMI Transmitter and the DDC SCL speed is not affected by the pixel clock frequency.

The DDC output port is also used by the auto-synchronous RI check. For proper handshaking, refer to the RI_Started bit in the RI_STAT register (0x72.0x26[0]), described on page 190.

Note: The DDC_CMD, DDC_DATA and DDC_STATUS registers are not accessible if PDOSC#=0 or PDTOT#=0.

DDC I²C MANUAL REGISTER

Dev	Addr	Name	7	6	5	4	3	2	1	0
0x72	0xEC	DDC_MAN	RSVDRW0						IO_SCL	IO_SDA
Bit	Label	R/W	Description						Default	
1	IO_SDA	R	DDC SDA input state.						0	
0	IO_SCL	R	DDC SCL input state.						0	

Note: The default values of IO_SCL and IO_SDA depend on the condition of DDC bus.

DDC I²C TARGET SLAVE ADDRESS REGISTER

Dev	Addr	Name	7	6	5	4	3	2	1	0
0x72	0xED	DDC_ADDR	DDC_ADDR							RSVD0
Bit	Label	R/W	Description						Default	
7:1	DDC_ADDR	R/W	DDC device address.						0b0000000	

DDC I²C TARGET SEGMENT ADDRESS REGISTER

Dev	Addr	Name	7	6	5	4	3	2	1	0
0x72	0xEE	DDC_SEGM	DDC_SEGM							
Bit	Label	R/W	Description						Default	
7:0	DDC_SEGM	R/W	DDC segment address.						0x00	

DDC I²C TARGET OFFSET ADDRESS REGISTER

Dev	Addr	Name	7	6	5	4	3	2	1	0
0x72	0xEF	DDC_OFFSET	DDC_OFFSET							
Bit	Label	R/W	Description						Default	
7:0	DDC_OFFSET	R/W	DDC offset address.						0x00	

DDC I²C DATA COUNT REGISTER

Dev	Addr	Name	7	6	5	4	3	2	1	0	
0x72	0xF0	DDC_COUNT1	DDC_COUNT[7:0]								
0x72	0xF1	DDC_COUNT2	RSVDRW0						[9:8]		
Bit	Label	R/W	Description							Default	
9:0	DDC_COUNT	R/W	The total number of bytes to be read from the slave or written to the slave before a <i>Stop</i> bit is sent on the DDC bus.							0	

DDC I²C STATUS REGISTER

Dev	Addr	Name	7	6	5	4	3	2	1	0
0x72	0xF2	DDC_STATUS	RSVDRO	BUS_LOW	NO_ACK	IN_PROG	FIFO_FULL	FIFO_EMP	FRD_USE	FWT_USE
Bit	Label	R/W	Description							Default
6	BUS_LOW	R	1 = I ² C transaction did not start because I ² C bus is pulled LOW by an external device							0
5	NO_ACK	R	1 = HDMI Transmitter did not receive an ACK from slave device during address or data write							0
4	IN_PROG	R	1 = DDC operation in progress							0
3	FIFO_FULL	R	1 = DDC FIFO Full							0
2	FIFO_EMP	R	1 = DDC FIFO Empty							1
1	FRD_USE	R	1 = DDC FIFO Read In Use							0
0	FWT_USE	R	1 = DDC FIFO Write In Use							0

The DDC master feature recognizes and supports clock stretching by an I²C slave device. Clock stretching is described in the I²C Specification, Section 13.2.

DDC I²C COMMAND REGISTER

Dev	Addr	Name	7	6	5	4	3	2	1	0
0x72	0xF3	DDC_CMD	RSVD0	DDC_FLT_EN	SDA_DEL_EN	DDC_CMD				
Bit	Label	R/W	Description							Default
5	DDC_FLT_EN	R/W	Enable the DDC delay: 0 = Enabled 1 = Disabled A DDC delay is inserted into the SDA line to create a 300ns delay for the falling edge of the DDC SDA signal to avoid an erroneous I ² C START condition. The real start condition must have a setup time of 600ns so that this delay of 300ns does not remove the real START condition. Filtering is done using a Ring Oscillator.							0
4	SDA_DEL_EN	R/W	Enable 3ns glitch filtering on the DDC clock and data line: 0 = Enabled 1 = Disabled Filtering is done using a Ring Oscillator.							0

Dev	Addr	Name	7	6	5	4	3	2	1	0
3:0	DDC_CMD	R/W	DDC command: 0b1111 = Abort Transaction 0b1001 = Clear FIFO 0b1010 = Clock SCL 0b0000 = Current Address Read with no ACK on last byte 0b0010 = Sequential Read with no ACK on last byte 0b0100 = Enhanced DDC Read with no ACK on last byte 0b0110 = Sequential Write ignoring ACK on last byte 0b0111 = Sequential Write requiring ACK on last byte Writing to this register immediately initiates the I ² C transaction on the DDC bus. Note: The Clear FIFO command resets the FIFO read and write pointers to zero. Data formerly loaded into the FIFO cannot be re-read after a Clear FIFO, as the FIFO will be empty. Other command codes are reserved and may cause the DDC bus to hang if used. The Clock SCL command resets any I ² C devices on the DDC lines. This should be initiated once before initiating the DDC commands.							0b0000

DDC I²C DATA REGISTER

Dev	Addr	Name	7	6	5	4	3	2	1	0
0x72	0xF4	DDC_DATA	DDC_DATA							
Bit	Label	R/W	Description							Default
7:0	DDC_DATA	R	DDC data input.							0xFF

The FIFO supports multi-byte sequential read commands from the controller. Such a command is diagrammed in Figure 18 on page 255. Up to 16 bytes can be read in one local I²C command. Data bytes continue to be put into the FIFO as long as it is not full.

DDC I²C FIFO COUNT REGISTER

Dev	Addr	Name	7	6	5	4	3	2	1	0
0x72	0xF5	DDC_FIFOCNT	RSVDRW0			DDC_FIFOCNT				
Bit	Label	R/W	Description							Default
4:0	DDC_FIFOCNT	R	FIFO data byte count (the number of bytes in the FIFO). The DDC FIFO size is 16. The maximum value for DDC_FIFOCNT is 0x10.							0x00

Audio Registers

The HDMI link does *not* transport an explicit audio master clock, it encodes the frequency of that clock in N/CTS Packets sent during command times. The ratio of the current pixel clock frequency to the desired MCLK frequency is defined by a numerator, N and a denominator, CTS. Whenever the pixel clock frequency changes (the video mode changes), or the audio clock changes (the audio sampling rate changes), the N value must also be updated.

ACR CONTROL REGISTER

Dev	Addr	Name	7	6	5	4	3	2	1	0
0x7A	0x01	ACR_CTRL	RSVD0						NCTSPKT_EN	CTS_SEL
Bit	Label	R/W	Description							Default
1	NCTSPKT_EN	R/W	CTS Request Enable: 0 = N/CTS packet disabled 1 = N/CTS packet enabled							1
0	CTS_SEL	R/W	CTS Source Select: 0 = Send HW-updated CTS value in N/CTS packet (recommended) 1 = Send SW-updated CTS value in N/CTS packet (for diagnostic use) Note: FUJITSU recommends that you do <i>not</i> set this bit to 1.							0

ACR AUDIO FREQUENCY REGISTER

Dev	Addr	Name	7	6	5	4	3	2	1	0	
0x7A	0x02	FREQ_SVAL	RSVD0						MCLK_CONF		
Bit	Label	R/W	Description							Default	
2:0	MCLK_CONF	R/W	MCLK input mode: 0b000 = MCLK is 128*Fs 0b001 = MCLK is 256*Fs 0b010 = MCLK is 384*Fs 0b011 = MCLK is 512*Fs 0b100 = MCLK is 768*Fs 0b101 = MCLK is 1024*Fs 0b110 = MCLK is 1152*Fs 0b111 = MCLK is 192*Fs The HDMI Transmitter uses these bits to divide the MCLK input to produce CTS values according to the 128*Fs formula. The MCLK to Fs ratio is for the input Fs, not the down-sampled output Fs (see the ASRC register (0x7A:0x23), on page 213).							0b001	

ACR N SOFTWARE VALUE REGISTER

Dev	Addr	Name	7	6	5	4	3	2	1	0
0x7A	0x03	N_SVAL1	N_SVAL[7:0]							
0x7A	0x04	N_SVAL2	N_SVAL[15:8]							
0x7A	0x05	N_SVAL3	RSVD0				N_SVAL[19:16]			
Bit	Label	R/W	Description							Default
19:0	N_SVAL	R/W	N Value for audio clock regeneration method; a 20-bit value. This must be written to the registers to create the correct divisor for audio clock regeneration. Only values greater than 0 are valid. This register must be written after a hardware reset.							0

ACR CTS SOFTWARE VALUE REGISTER

Dev	Addr	Name	7	6	5	4	3	2	1	0
0x7A	0x06	CTS_SVAL1	CTS_SVAL[7:0]							
0x7A	0x07	CTS_SVAL2	CTS_SVAL[15:8]							
0x7A	0x08	CTS_SVAL3	RSVDO				CTS_SVAL[19:16]			
Bit	Label	R/W	Description							Default
19:0	CTS_SVAL	R/W	CTS Value for audio clock regeneration method; a 20-bit value. Diagnostic use and applied only when the CTS_SEL bit (0x7A:0x01[0]) is set to 1.							0

ACR CTS HARDWARE VALUE REGISTERS

Dev	Addr	Name	7	6	5	4	3	2	1	0
0x7A	0x09	CTS_HVAL1	CTS_HVAL[7:0]							
0x7A	0x0A	CTS_HVAL2	CTS_HVAL[15:8]							
0x7A	0x0B	CTS_HVAL3	RSVDO				CTS_HVAL[19:16]			
Bit	Label	R/W	Description							Default
19:0	CTS_HVAL	R	CTS Value for audio clock regeneration method; a 20-bit value. This value is measured and stored here by the hardware when MCLK is active and N is valid, after 128Fs/N cycles of MCLK.							X

AUDIO IN MODE REGISTER

Dev	Add	Name	7	6	5	4	3	2	1	0
0x7A	0x14	AUD_MODE	SD3_EN	SD2_EN	SD1_EN	SD0_EN	RSVDRW0	RSVDRW0	SPDIF_EN	AUD_EN
Bit	Label	R/W	Description		Default					
7	SD3_EN	R/W	I ² S input channel #3 enable.		0					
6	SD2_EN	R/W	I ² S input channel #2 enable.		0					
5	SD1_EN	R/W	I ² S input channel #1 enable.		0					
4	SD0_EN	R/W	I ² S input channel #0 enable.		0					
1	SPDIF_EN	R/W	S/PDIF input stream enable: 0 = Disabled 1 = Enabled		0					
0	AUD_EN	R/W	Audio input stream enable: 0 = Disabled 1 = Enabled		0					

Audio input data is selected from either the S/PDIF input or the I²S inputs. Audio input data can be disabled by clearing the AUD_EN bit. See Figure 10 on page 224.

See the note on the HDMI Transmitter's limitation in assigning the I²S channels to audio FIFOs, on page 211.

AUDIO IN S/PDIF CONTROL REGISTER

Dev	Addr	Name	7	6	5	4	3	2	1	0
0x7A	0x15	SPDIF_CTRL	RSVDRW0		NOAUDIO		RSVDRW0	FS_OVERRIDE		RSVDRW0
Bit	Label	R/W	Description							Default
3	NOAUDIO	R	No S/PDIF audio: 1 = No change detected on the S/PDIF input 0 = Detected change on the S/PDIF input							1
1	FS_OVERRIDE	R/W	S/PDIF input stream override: 0 = Use input S/PDIF stream's detected FS 1 = Use software FS in I2S_CHST4 register (0x7A:0x21)							0

AUDIO IN S/PDIF EXTRACTED FS AND LENGTH REGISTER

Dev	Addr	Name	7	6	5	4	3	2	1	0																					
0x7A	0x18	HW_SPDIF_FS	HW_SPDIF_LEN		HW_MAXLEN		HW_SPDIF_FS																								
Bit	Label	R/W	Description							Default																					
7:5	HW_SPDIF_LEN	R	Channel status bits 33 to 35 (bit 33=LSB, bit 35=MSB) Combines with HW_MAXLEN to indicate sample size: <table border="1" style="margin-left: auto; margin-right: auto;"> <thead> <tr> <th>Bits</th> <th>Max 24</th> <th>Max 20</th> </tr> </thead> <tbody> <tr> <td>000</td> <td colspan="2">not indicated</td> </tr> <tr> <td>001</td> <td>20 bits</td> <td>16 bits</td> </tr> <tr> <td>010</td> <td>22 bits</td> <td>18 bits</td> </tr> <tr> <td>100</td> <td>23 bits</td> <td>19 bits</td> </tr> <tr> <td>101</td> <td>24 bits</td> <td>20 bits</td> </tr> <tr> <td>110</td> <td>21 bits</td> <td>17 bits</td> </tr> </tbody> </table>							Bits	Max 24	Max 20	000	not indicated		001	20 bits	16 bits	010	22 bits	18 bits	100	23 bits	19 bits	101	24 bits	20 bits	110	21 bits	17 bits	110
Bits	Max 24	Max 20																													
000	not indicated																														
001	20 bits	16 bits																													
010	22 bits	18 bits																													
100	23 bits	19 bits																													
101	24 bits	20 bits																													
110	21 bits	17 bits																													
4	HW_MAXLEN	R	Maximum sample length (channel status bit 32): 1 = Maximum sample length is 24 bits 0 = Maximum sample length is 20 bits							1																					
3:0	HW_SPDIF_FS	R	Set to the FS extracted from the S/PDIF input channel status bits 24-27.							0000																					

AUDIO IN I²S CHANNEL SWAP REGISTER

Dev	Addr	Name	7	6	5	4	3	2	1	0
0x7A	0x19	SWAP_I2S	SWCH3	SWCH2	SWCH1	SWCH0	RSVDRW			
Bit	Label	R/W	Description							Default
7	SWCH3	R/W	Swap left-right channels for I ² S Channel 3: 0 = Do not swap left and right 1 = Swap left and right							0
6	SWCH2	R/W	Swap left-right channels for I ² S Channel 2.							0
5	SWCH1	R/W	Swap left-right channels for I ² S Channel 1.							0
4	SWCH0	R/W	Swap left-right channels for I ² S Channel 0.							0
3:0	RSVDRW	R/W	Reserved - do not modify.							0x9

Note: Each SWCH[3:0] bit is active *only* when the corresponding I²S input channel is enabled with register 0x7A:0x14.

AUDIO ERROR THRESHOLD REGISTER

Dev	Addr	Name	7	6	5	4	3	2	1	0
0x7A	0x1B	SPDIF_ERTH	RSVDRW0	RSVDRW1	AUD_ERR_THRESH					
Bit	Label	R/W	Description							Default
5:0	AUD_ERR_THRESH	R/W	Specifies the error threshold level. The frame is marked as invalid if the number of bi-phase mark encoding errors in the audio stream exceeds this threshold level during frame decoding.							0b001000

AUDIO IN I²S DATA IN MAP REGISTER

Dev	Addr	Name	7	6	5	4	3	2	1	0
0x7A	0x1C	I2S_IN_MAP	FIFO3_MAP	FIFO2_MAP	FIFO1_MAP			FIFO0_MAP		
Bit	Label	R/W	Description							Default
7:6	FIFO3_MAP	R/W	Channel map to FIFO #3 (for HDMI Layout 1): 0b00 = Map SD0 to FIFO #3 0b01 = Map SD1 to FIFO #3 0b10 = Map SD2 to FIFO #3 0b11 = Map SD3 to FIFO #3							0b11
5:4	FIFO2_MAP	R/W	Channel map to FIFO #2 (for HDMI Layout 1): 0b00 = Map SD0 to FIFO #2 0b01 = Map SD1 to FIFO #2 0b10 = Map SD2 to FIFO #2 0b11 = Map SD3 to FIFO #2							0b10
3:2	FIFO1_MAP	R/W	Channel map to FIFO #1 (for HDMI Layout 1): 0b00 = Map SD0 to FIFO #1 0b01 = Map SD1 to FIFO #1 0b10 = Map SD2 to FIFO #1 0b11 = Map SD3 to FIFO #1							0b01
1:0	FIFO0_MAP	R/W	Channel map to FIFO #0 (for HDMI Layout 0 or 1): 0b00 = Map SD0 to FIFO #0 0b01 = Map SD1 to FIFO #0 0b10 = Map SD2 to FIFO #0 0b11 = Map SD3 to FIFO #0							0b00

HDMI allows for up to eight channels of audio content. Two channels pass through each of the four FIFOs listed in the description for register 0x7A:0x1C. HDMI does not restrict the Source to use any specific subset of the FIFOs. For example, 4-channel content can use many combinations of two FIFOs and two fields in the Audio Packets (indicated by each packet's B.X and SP.X bits, see HDMI 1.1, Sections 5.3.4 and 7.6), limited only by the channel assignment choices in EIA/CEA-861B Section 8.3.2. The B and PR bits are set automatically in each Audio InfoFrame packet by the HDMI Transmitter logic, using both the 0x1C register settings and the I²S channel enables in the 0x7A:0x14 register.

Some HDMI Receiver chips may not make the arriving B and PR bit information accessible to the Sink's firmware. Therefore, the only indicator of *used audio channels* is in the Audio InfoFrame packet's Data Byte 4.

AUDIO IN I²S CONTROL REGISTER

Dev	Addr	Name	7	6	5	4	3	2	1	0
0x7A	0x1D	I2S_IN_CTRL	RSVD0	SCK_EDGE	RSVD0		I2S_WS	I2S_JUST	I2S_DIR	I2S_SHIFT
Bit	Label	R/W	Description							Default
6	SCK_EDGE	R/W	SCK sample edge: 0 = Sample edge is falling; SD3-SD0 and WS source should change state on the rising edge of SCK 1 = Sample clock is rising; SD3-SD0 and WS source should change state on the falling edge of SCK							1
3	I2S_WS	R/W	WS polarity: 0 = Left polarity when WS is LOW 1 = Left polarity when WS is HIGH							0
2	I2S_JUST	R/W	SD justify: 0 = Data is left-justified 1 = Data is right-justified							1
1	I2S_DIR	R/W	SD direction: 0 = MSB shifted first 1 = LSB shifted first							0
0	I2S_SHIFT	R/W	WS to SD first bit shift: 0 = First bit shift (refer to the Philips Specification) 1 = No shift							1

AUDIO IN I²S CHANNEL STATUS REGISTERS

Dev	Addr	Name	7	6	5	4	3	2	1	0																					
0x7A	0x1E	I2S_CHST1	cbit7	cbit6	cbit5	cbit4	cbit3	cbit2	cbit1	cbit0																					
0x7A	0x1F	I2S_CHST2	cbit15	cbit14	cbit13	cbit12	cbit11	cbit10	cbit9	cbit8																					
0x7A	0x20	I2S_CHST3	I2S_CHAN_NUM				I2S_SRC_NUM																								
0x7A	0x21	I2S_CHST4	CLK_ACCUR				SW_SPDIF_FS																								
0x7A	0x22	I2S_CHST5	FS_ORIG				I2S_LEN			I2S_MAXLEN																					
Bit	Label	R/W	Description							Default																					
7:0	I2S_CHST1	R/W	Channel Status Byte #0							0x00																					
7:0	I2S_CHST2	R/W	Channel Status Byte #1: Category Code							0x00																					
7:4	I2S_CHAN_NUM	R/W	Channel Status Byte #2: Source Number							0b0000																					
3:0	I2S_SRC_NUM	R/W	Channel Status Byte #3: Source Number							0b0000																					
7:4	CLK_ACCUR	R/W	Clock Accuracy							0b0000																					
3:0	SW_SPDIF_FS	R/W	Sampling frequency as set by software. If S/PDIF source is connected, this value will be inserted into the S/PDIF stream if FS_OVERRIDE is enabled. See note below.							0b1111																					
7:4	FS_ORIG	R/W	Original Fs							0b0000																					
3:1	I2S_LEN	R/W	Audio sample word length: Defined in bits with I2S_MAXLEN: <table border="1" style="margin-left: 20px;"> <thead> <tr> <th>I2S_LEN</th> <th>I2S_MAXLEN=0</th> <th>I2S_MAXLEN=1</th> </tr> </thead> <tbody> <tr> <td>0b000</td> <td>not indicated</td> <td>not indicated</td> </tr> <tr> <td>0b001</td> <td>16</td> <td>20</td> </tr> <tr> <td>0b010</td> <td>18</td> <td>22</td> </tr> <tr> <td>0b100</td> <td>19</td> <td>23</td> </tr> <tr> <td>0b101</td> <td>20</td> <td>24</td> </tr> <tr> <td>0b110</td> <td>17</td> <td>21</td> </tr> </tbody> </table>							I2S_LEN	I2S_MAXLEN=0	I2S_MAXLEN=1	0b000	not indicated	not indicated	0b001	16	20	0b010	18	22	0b100	19	23	0b101	20	24	0b110	17	21	0b000
I2S_LEN	I2S_MAXLEN=0	I2S_MAXLEN=1																													
0b000	not indicated	not indicated																													
0b001	16	20																													
0b010	18	22																													
0b100	19	23																													
0b101	20	24																													
0b110	17	21																													
0	I2S_MAXLEN	R/W	Maximum audio sample word length 0 = 20 bits 1 = 24 bits							1																					

Note: The word length bits [3:0] should always match the word length of the audio samples coming into the HDMI Transmitter, even if the audio is down-sampled in the Transmitter. The word length of the input I²S stream is set in

the 0x7A:0x24 register, described on page 214. Audio stream down sampling is enabled in the 0x7A:0x23 register, described on page 213.

HDMI 1.0 requires that accurate channel status information be transmitted in the Audio InfoFrames. When the audio is supplied to the HDMI Transmitter at the S/PDIF input, the channel status is extracted from the S/PDIF stream. When the audio is supplied by I²S inputs, the firmware must write accurate values into the channel status registers. Refer to IEC 60958-3 for detailed definitions of the channel status bits. The channel status information is used in the HDMI Receiver to reconstruct the audio into I²S format.

When down-sampling the audio stream (see the ASRC register on page 213), both CHST5 and CHST4 should be loaded with the original (input) Fs rate. The chip sends the original Fs in the audio packet channel status bits corresponding to CHST5, divides the original Fs rate (according to register ASRC), and sends that slower Fs in the bits corresponding to CHST4. Always write the input Fs into CHST4 and CHST5 when connected to an I²S source. A S/PDIF source loads both bytes automatically.

If FS_OVERRIDE is set to 0 (0x7A:0x15[1]), the sampling frequency is extracted from the S/PDIF input stream. It is encoded in that stream's Channel Status bits as shown in Table 20.

TABLE 20 ENCODED AUDIO SAMPLING FREQUENCY

CH_ST				Fs Sampling Frequency
3	2	1	0	
0	0	0	0	44.1kHz
1	0	0	0	88.2kHz
1	1	0	0	176.4kHz
0	0	1	0	48kHz
1	0	1	0	96kHz
1	1	1	0	192kHz
0	0	1	1	32kHz
0	0	0	1	no indicated

Note: The value in FS_OVERRIDE is provided to assist with source systems that do not provide correct FS information in the raw S/PDIF stream. The HDMI Specification requires the transmitted FS value to be correct in the channel status bits of the audio sample packets (see Section 7.3). By setting FS_OVERRIDE to 1, the HDMI Transmitter can be programmed (in SW_SPDIF_FS) with the correct FS value and can ignore the value in the input S/PDIF stream. Values not listed in Table 20 are reserved.

AUDIO SAMPLE RATE CONVERSION REGISTER

Dev	Addr	Name	7	6	5	4	3	2	1	0
0x7A	0x23	ASRC	RSVDRW0						RATIO	SRC_EN
Bit	Label	R/W	Description							Default
1	RATIO	R/W	Sample rate down-conversion ratio: 0 = Down-sample 2-to-1 when SRC_EN is set to 1 1 = Down-sample 4-to-1 when SRC_EN is set to 1							0
0	SRC_EN	R/W	Audio sample rate conversion: 0 = Disabled 1 = Enabled							0

Sample rate conversion is applied only to 2-channel audio, either from the S/PDIF input or from the I²S Channel 0 input. Setting register ASRC to 0x01, down-samples 96KHz audio to 48KHz and 88.2KHz to 44.1KHz. Setting ASRC to 0x02, down-samples 192KHz to 48KHz and 174.4KHz to 44.1KHz. This conversion is performed after selecting S/PDIF or I²S input paths to the HDMI Transmitter. The CHST5 bits written in register 0x7A:0x22 should always indicate the sample rate before any down-sampling (see page 212).

If an audio source is connected to both the HDMI Transmitter and an audio DAC, the audio source may output 196KHz (or 176.4KHz) audio to drive the DAC and the Transmitter. The DAC uses the higher sample rate, while the

HDMI Transmitter simultaneously down-samples that stream to the 48KHz (or 44.1KHz) sample rate. 48KHz and 44.1KHz are the default audio rates for HDMI.

The N value and the I²S channel status registers should be set per input audio configuration. The N value is affected by the down-sampling so that the outgoing N value in the N/CTS packets represents the video-to-audio ratio for the down-sampled audio stream. For example, to input 96kHz audio with 74.25MHz video input and to output 48kHz audio, the N register value should be set to 12288. This N will be divided by the down-sample RATIO, so that the HDMI Transmitter outputs packets with N=6144.

Important: Sample rate conversion works only for 2-channel PCM audio; you must set LAYOUT to 0 in register 0x7A:0x2F.

AUDIO I²S INPUT LENGTH REGISTER

Dev	Addr	Name	7	6	5	4	3	2	1	0
0x7A	0x24	I2S_IN_LEN	RSVDRW0				IN_LENGTH			
Bit	Label	R/W	Description							Default
3:0	IN_LENGTH	R/W	Number of valid bits in the input I ² S stream. Used for the extraction of the I ² S data from the input stream. 0b1111 - 0b1110 = N/A 0b1101 = 21 bit 0b1100 = 17 bit 0b1011 = 24 bit 0b1010 = 20 bit 0b1001 = 23 bit 0b1000 = 19 bit 0b0111 - 0b0110 = N/A 0b0101 = 22 bit 0b0100 = 18 bit 0b0011 = N/A 0b0010 = 16 bit 0b0001 - 0b0000 = N/A							0b1011

HDMI CONTROL REGISTER

Dev	Addr	Name	7	6	5	4	3	2	1	0
0x7A	0x2F	HDMI_CTRL	RSVD0	RSVDRW	PACKET_MODE			LAYOUT		HDMI_MODE
Bit	Label	R/W	Description							Default
5:3	PACKET_MODE	R/W	Specifies the number of bits per pixel sent to the packetizer: 0b000 = Reserved 0b001 = Reserved 0b010 = Reserved 0b011 = Reserved 0b100 = 24 bits per pixel (8 bits per pixel; no packing) 0b101 = 30 bits per pixel (10 bits per pixel pack to 8 bits) 0b110 = 36 bits per pixel (12 bits per pixel pack to 8 bits) 0b111 = 48 bits per pixel (16 bits per pixel; no packing) Note: The firmware must program 24 bits per pixel (8 bits per pixel; no packing) for initialization.							0b000
2:1	LAYOUT	R/W	Audio packet header layout indicator: 0b00 = Layout 0 (2-channel)							0b00

Dev	Addr	Name	7	6	5	4	3	2	1	0	
			0b01 = Layout 1 (up to 8 channels) 0b1x = Reserved								
0	HDMI_MODE	R/W	HDMI mode: 0 = Disabled 1 = Enabled							0	

AUDIO PATH STATUS REGISTER

Dev	Addr	Name	7	6	5	4	3	2	1	0	
0x7A	0x30	AUDO_TXSTAT	RSVD0						MUTE	RSVD0	
Bit	Label	R/W	Description							Default	
2	MUTE	R	<p>General Control Packet mute status: 0 = No packet with SETAVM=1 has been sent. 1 = A packet with SETAVM=1 has been sent.</p> <p>The MUTE bit is equal to the SETAVM bit in register 0x7A.0xDF, described on page 221. MUTE is not set immediately when the SETAVM bit in register 0xDF is written. After writing SETAVM to 1, MUTE is set after Control Packet is transmitted in HDMI mode. In DVI mode, MUTE is set at the start of VSYNC. MUTE is cleared when a Control Packet with CLRAVM=1 is sent, or (in DVI mode) at the start of VSYNC after CLRAVM has been written to 1.</p> <p>Note: The combinations {SETAVM, CLRAVM}={0,0} and {1,1} are not supported by <i>HDMI 1.0 Specification</i>, Section 5.3.6. For more details see page 222.</p>								

DIAGNOSTIC POWER DOWN REGISTER

Dev	Addr	Name	7	6	5	4	3	2	1	0	
0x7A	0x3D	DPD	RSVDRW0				TCLKPHZ#	PDIDCK#	PDOSC#	PDTOT#	
Bit	Label	R/W	Description							Default	
3	TCLKPHZ#	R/W	<p>Selects the TCLK phase: 0 = Invert TCLK; change the phase 180 degrees 1 = Default phase; the same as TMDS core</p>							1	
2	PDIDCK#	R/W	<p>Power down IDCK input: 0 = Power down; gate off IDCK signal to disable all IDCK-based logic 1 = Normal operation</p>							1	
1	PDOSC#	R/W	<p>Power down Internal Oscillator. This disables the I²C port to the internal ROM (disabling loading), halts all interrupt updates, and disables the Master DDC block. 0 = Power down 1 = Normal operation</p>							1	
0	PDTOT#	R/W	<p>Power down total: 0 = Power down everything; INT source is RSEN. 1 = Normal operation</p>							1	

Refer to the page 259 for details on the restrictions for using these power-down bits.

Packet Registers

For all the packets described in the following registers, the packet transmission is controlled by two bits that allow the packet to be sent once or repeatedly. To send a packet one time, set the *enable* bit only after the corresponding packet data has been written into the appropriate registers. Read the enable bit to determine if the packet has actually been transmitted across the link. When cleared to zero, the packet has been transmitted.

If you want to send the packet repeatedly, write the *repeat* bit to 1 at the same time as enable is set to 1. This sends the corresponding packet during every VBLANK period.

To disable the repeated transmission, clear the repeat and enable bits simultaneously.

To guarantee that the HDMI Receiver remains in HDMI mode, at least one HDMI packet must be transmitted every two VSYNC periods (see the HDMI Specification, Section 5.2.3.2). This is accomplished automatically whenever audio is being transmitted, but if audio has not yet been enabled or if the HDMI Transmitter is not sending audio for some other reason, it is recommended that a Null Packet (all zeroes) be transmitted during every VBLANK. This can be accomplished by setting the contents of the Generic Packet buffer to all zeroes and then setting both enable and repeat bits for that packet.

The ID, TYPE, checksum, and length fields in each HDMI InfoFrame must be loaded by the microcontroller. There is no internal logic for calculating the checksum automatically, or any preset length value.

Note: The enable bits in registers 0x7A:0x3E-0x3F can only be set or cleared when the HDMI Transmitter is *not* in a powered-down state. The following bits must not be set: PD# (0x72:0x08[0]) and PDTOT# (0x7A:0x3D[0]). See page 159 for more details on power-down bits. Also, IDCK must be active. The data bytes in each InfoFrame, as well as the SETAVM/CLRAVM bits in the Control Packet and the repeat bit for each packet type can be written when the HDMI Transmitter is powered-down. Therefore, the firmware can write all necessary registers except the enable bits, then de-assert any power-down bits, and finally write any necessary enable bits.

Note: The enable and repeat bits for the various packet types are not affected by the state of the HDMI_MODE bit (register 0x7A:0x2F[0], described on page 214). Although packets cannot be transmitted in DVI mode (when HDMI_MODE is set to 0), and the HDMI Transmitter ignores the states of registers 0x3E-0x3F when HDMI_MODE is set to 0, the firmware should clear the packet enable and repeat bits whenever switching to DVI mode so that the status of packet sending, when read back from registers 0x3E-0x3F, is consistent with the link mode. All packet enables and repeats are set to their default values after hardware reset.

PACKET BUFFER CONTROL #1 REGISTER

Dev	Addr	Name	7	6	5	4	3	2	1	0
0x7A	0x3E	PB_CTRL1	MPEG_EN	MPEG_RPT	AUD_EN	AUD_RPT	SPD_EN	SPD_RPT	AVI_EN	AVI_RPT
Bit	Label	R/W	Description							Default
7	MPEG_EN	R/W	Enable MPEG InfoFrame transmission: 0 = Disabled 1 = Enabled							0
6	MPEG_RPT	R/W	Repeat MPEG InfoFrame transmission: 0 = Disabled (send once after <i>enable</i> bit is set) 1 = Enabled (send in every VBLANK period)							0
5	AUD_EN	R/W	Enable Audio InfoFrame transmission: 0 = Disabled 1 = Enabled							0
4	AUD_RPT	R/W	Repeat Audio InfoFrame transmission: 0 = Disabled (send once after <i>enable</i> bit is set) 1 = Enabled (send in every VBLANK period)							0
3	SPD_EN	R/W	Enable SPD InfoFrame transmission: 0 = Disabled 1 = Enabled							0
2	SPD_RPT	R/W	Repeat SPD InfoFrame transmission: 0 = Disabled (send once after <i>enable</i> bit is set) 1 = Enabled (send in every VBLANK period)							0
1	AVI_EN	R/W	Enable AVI InfoFrame transmission: 0 = Disabled 1 = Enabled							0
0	AVI_RPT	R/W	Repeat AVI InfoFrame transmission: 0 = Disabled (send once after <i>enable</i> bit is set) 1 = Enabled (send in every VBLANK period)							0

PACKET BUFFER CONTROL #2 REGISTER

Dev	Addr	Name	7	6	5	4	3	2	1	0
0x7A	0x3F	PB_CTRL2	RSVDO		GEN2_EN	GEN2_RPT	CP_EN	CP_RPT	GEN_EN	GEN_RPT
Bit	Label	R/W	Description							Default
5	GEN2_EN	R/W	Enable Generic #2 Packet transmission: 0 = Disabled 1 = Enabled							0
4	GEN2_RPT	R/W	Repeat Generic #2 Packet transmission: 0 = Disabled (send once after <i>enable</i> bit is set) 1 = Enabled (send in every VBLANK period)							0
3	CP_EN	R/W	Enable General Control Packet transmission: 0 = Disabled 1 = Enabled							0
2	CP_RPT	R/W	Repeat General Control Packet transmission: 0 = Disabled (send once after <i>enable</i> bit is set) 1 = Enabled (send in every VBLANK period)							0
1	GEN_EN	R/W	Enable Generic Packet transmission: 0 = Disabled 1 = Enabled							0
0	GEN_RPT	R/W	Repeat Generic Packet transmission: 0 = Disable (send once after <i>enable</i> bit is set) 1 = Enable (send in every VBLANK period)							0

Note: The PB_CTRL1 and PB_CTRL2 registers cannot be written when PD#=0, PDTOT#=0, or PDIDCK#=0; or if IDCK is inactive.

PACKET REGISTERS

Refer to the HDMI and CEA-861B Specifications for a detailed explanation of these register fields.

Dev	Addr	Name	7	6	5	4	3	2	1	0
0x7A	0x40	AVI_TYPE	AVI_HDR[7:0]							
0x7A	0x41	AVI_VERS	AVI_HDR[15:8]							
0x7A	0x42	AVI_LEN	AVI_HDR[23:16]							
0x7A	0x43	AVI_CHSUM	AVI_HDR[31:24]							
0x7A	0x44	AVI_DBYTE1	AVI_DATA							
0x7A	0x45	AVI_DBYTE2								
0x7A	0x46	AVI_DBYTE3								
0x7A	0x47	AVI_DBYTE4								
0x7A	0x48	AVI_DBYTE5								
0x7A	0x49	AVI_DBYTE6								
0x7A	0x4A	AVI_DBYTE7								
0x7A	0x4B	AVI_DBYTE8								
0x7A	0x4C	AVI_DBYTE9								
0x7A	0x4D	AVI_DBYTE10								
0x7A	0x4E	AVI_DBYTE11								
0x7A	0x4F	AVI_DBYTE12								
0x7A	0x50	AVI_DBYTE13								
0x7A	0x51	AVI_DBYTE14								
0x7A	0x52	AVI_DBYTE15								
Bit	Label	R/W	Description						Default	
7:0	AVI_TYPE	R/W	AVI InfoFrame Type Code.						0x00	
7:0	AVI_VERS	R/W	AVI InfoFrame Version Code.						0x00	
7:0	AVI_LEN	R/W	AVI InfoFrame Length.						0x00	
7:0	AVI_CHSUM	R/W	AVI InfoFrame Checksum.						0x00	
	AVI_DATA	R/W	AVI InfoFrame Data Bytes.							

Refer to the page 252 for more details on the fields and valid settings in the AVI InfoFrame.

SPD INFOFRAME REGISTERS

Refer to the CEA-861B Specification for a detailed explanation of these register fields.

Dev	Addr	Name	7	6	5	4	3	2	1	0
0x7A	0x60	SPD_TYPE	SPD_HDR[7:0]							
0x7A	0x61	SPD_VERS	SPD_HDR[15:8]							
0x7A	0x62	SPD_LEN	SPD_HDR[23:16]							
0x7A	0x63	SPD_CHSUM	SPD_HDR[31:24]							
0x7A	0x64	SPD_DBYTE1	SPD_DATA							
0x7A	0x65	SPD_DBYTE2								
0x7A	0x66	SPD_DBYTE3								
0x7A	0x67	SPD_DBYTE4								
0x7A	0x68	SPD_DBYTE5								
0x7A	0x69	SPD_DBYTE6								
0x7A	0x6A	SPD_DBYTE7								
0x7A	0x6B	SPD_DBYTE8								

Dev	Addr	Name	7	6	5	4	3	2	1	0
0x7A	0x6C	SPD_DBYTE9								
0x7A	0x6D	SPD_DBYTE10								
0x7A	0x6E	SPD_DBYTE11								
0x7A	0x6F	SPD_DBYTE12								
0x7A	0x70	SPD_DBYTE13								
0x7A	0x71	SPD_DBYTE14								
0x7A	0x72	SPD_DBYTE15								
0x7A	0x73	SPD_DBYTE16								
0x7A	0x74	SPD_DBYTE17								
0x7A	0x75	SPD_DBYTE18								
0x7A	0x76	SPD_DBYTE19								
0x7A	0x77	SPD_DBYTE20								
0x7A	0x78	SPD_DBYTE21								
0x7A	0x79	SPD_DBYTE22								
0x7A	0x7A	SPD_DBYTE23								
0x7A	0x7B	SPD_DBYTE24								
0x7A	0x7C	SPD_DBYTE25								
0x7A	0x7D	SPD_DBYTE26								
0x7A	0x7E	SPD_DBYTE27								
Bit	Label	R/W	Description							Default
7:0	SPD_TYPE	R/W	SPD InfoFrame Type Code.							0x00
7:0	SPD_VERS	R/W	SPD InfoFrame Version Code.							0x00
7:0	SPD_LEN	R/W	SPD InfoFrame Length.							0x00
7:0	SPD_CHSUM	R/W	SPD InfoFrame Checksum.							0x00
	SPD_DATA	R/W	SPD InfoFrame Data Bytes.							

AUDIO INFOFRAME REGISTERS

Refer to the HDMI and CEA-861B Specifications for a detailed explanation of these register fields.

Dev	Addr	Name	7	6	5	4	3	2	1	0
0x7A	0x80	AUDIO_TYPE	AUDIO_HDR[7:0]							
0x7A	0x81	AUDIO_VERS	AUDIO_HDR[15:8]							
0x7A	0x82	AUDIO_LEN	AUDIO_HDR[23:16]							
0x7A	0x83	AUDIO_CHSUM	AUDIO_HDR[31:24]							
0x7A	0x84	AUDIO_DBYTE1	AUDIO_DATA							
0x7A	0x85	AUDIO_DBYTE2								
0x7A	0x86	AUDIO_DBYTE3								
0x7A	0x87	AUDIO_DBYTE4								
0x7A	0x88	AUDIO_DBYTE5								
0x7A	0x89	AUDIO_DBYTE6								
0x7A	0x8A	AUDIO_DBYTE7								
0x7A	0x8B	AUDIO_DBYTE8								
0x7A	0x8C	AUDIO_DBYTE9								
0x7A	0x8D	AUDIO_DBYTE10								
Bit	Label	R/W	Description							Default
7:0	AUDIO_TYPE	R/W	AUDIO InfoFrame Type Code.							0x00

Dev	Addr	Name	7	6	5	4	3	2	1	0	
7:0	AUDIO_VERS	R/W	AUDIO InfoFrame Version Code.							0x00	
7:0	AUDIO_LEN	R/W	AUDIO InfoFrame Length.							0x00	
7:0	AUDIO_CHSUM	R/W	AUDIO InfoFrame Checksum.							0x00	
	AUDIO_DATA	R/W	AUDIO InfoFrame Data Bytes.								

MPEG INFOFRAME REGISTERS

Refer to the CEA-861B Specification for a detailed explanation of these register fields.

Dev	Addr	Name	7	6	5	4	3	2	1	0
0x7A	0xA0	MPEG_TYPE	MPEG_HDR[7:0]							
0x7A	0xA1	MPEG_VERS	MPEG_HDR[15:8]							
0x7A	0xA2	MPEG_LEN	MPEG_HDR[23:16]							
0x7A	0xA3	MPEG_CHSUM	MPEG_HDR[31:24]							
0x7A	0xA4	MPEG_DBYTE1	MPEG_DATA							
0x7A	0xA5	MPEG_DBYTE2								
0x7A	0xA6	MPEG_DBYTE3								
0x7A	0xA7	MPEG_DBYTE4								
0x7A	0xA8	MPEG_DBYTE5								
0x7A	0xA9	MPEG_DBYTE6								
0x7A	0xAA	MPEG_DBYTE7								
0x7A	0xAB	MPEG_DBYTE8								
0x7A	0xAC	MPEG_DBYTE9								
0x7A	0xAD	MPEG_DBYTE10								
0x7A	0xAE	MPEG_DBYTE11								
0x7A	0xAF	MPEG_DBYTE12								
0x7A	0xB0	MPEG_DBYTE13								
0x7A	0xB1	MPEG_DBYTE14								
0x7A	0xB2	MPEG_DBYTE15								
0x7A	0xB3	MPEG_DBYTE16								
0x7A	0xB4	MPEG_DBYTE17								
0x7A	0xB5	MPEG_DBYTE18								
0x7A	0xB6	MPEG_DBYTE19								
0x7A	0xB7	MPEG_DBYTE20								
0x7A	0xB8	MPEG_DBYTE21								
0x7A	0xB9	MPEG_DBYTE22								
0x7A	0xBA	MPEG_DBYTE23								
0x7A	0xBB	MPEG_DBYTE24								
0x7A	0xBC	MPEG_DBYTE25								
0x7A	0xBD	MPEG_DBYTE26								
0x7A	0xBE	MPEG_DBYTE27								
Bit	Label	R/W	Description							Default
7:0	MPEG_TYPE	R/W	MPEG InfoFrame Type Code.							0x00
7:0	MPEG_VERS	R/W	MPEG InfoFrame Version Code.							0x00
7:0	MPEG_LEN	R/W	MPEG InfoFrame Length.							0x00
7:0	MPEG_CHSUM	R/W	MPEG InfoFrame Checksum.							0x00
	MPEG_DATA	R/W	MPEG InfoFrame Data Bytes.							

GENERIC PACKET REGISTERS

These registers may be used to transmit any type of packet.

Dev	Addr	Name	7	6	5	4	3	2	1	0
0x7A	0xC0	GEN_DBYTE1	GEN_DATA							
0x7A	0xC1	GEN_DBYTE2								
0x7A	0xC2	GEN_DBYTE3								
0x7A	0xC3	GEN_DBYTE4								
0x7A	0xC4	GEN_DBYTE5								
0x7A	0xC5	GEN_DBYTE6								
0x7A	0xC6	GEN_DBYTE7								
0x7A	0xC7	GEN_DBYTE8								
0x7A	0xC8	GEN_DBYTE9								
0x7A	0xC9	GEN_DBYTE10								
0x7A	0xCA	GEN_DBYTE11								
0x7A	0xCB	GEN_DBYTE12								
0x7A	0xCC	GEN_DBYTE13								
0x7A	0xCD	GEN_DBYTE14								
0x7A	0xCE	GEN_DBYTE15								
0x7A	0xCF	GEN_DBYTE16								
0x7A	0xD0	GEN_DBYTE17								
0x7A	0xD1	GEN_DBYTE18								
0x7A	0xD2	GEN_DBYTE19								
0x7A	0xD3	GEN_DBYTE20								
0x7A	0xD4	GEN_DBYTE21								
0x7A	0xD5	GEN_DBYTE22								
0x7A	0xD6	GEN_DBYTE23								
0x7A	0xD7	GEN_DBYTE24								
0x7A	0xD8	GEN_DBYTE25								
0x7A	0xD9	GEN_DBYTE26								
0x7A	0xDA	GEN_DBYTE27								
0x7A	0xDB	GEN_DBYTE28								
0x7A	0xDC	GEN_DBYTE29								
0x7A	0xDD	GEN_DBYTE30								
0x7A	0xDE	GEN_DBYTE31								
Bit	Label	R/W	Description						Default	
	GEN_DATA	R/W	Generic Packet Data Bytes.							

GENERAL CONTROL PACKET REGISTER

Dev	Addr	Name	7	6	5	4	3	2	1	0
0x7A	0xDF	CP_BYTE1	RSVD0			CLRAVM	RSVD0			SETAVM
Bit	Label	R/W	Description							Default
4	CLRAVM	R/W	Clear AV Mute flag.							0
0	SETAVM	R/W	Set AV Mute flag.							0

Note: Before enabling Control Packet transmission (CP_EN, CP_RPT), the firmware must write 0x10 or 0x01 to this register. The default value of 0x00 is not valid in a transmitted Control Packet.

GENERIC PACKET #2 REGISTERS

These registers may be used to transmit any type of packet.

Dev	Addr	Name	7	6	5	4	3	2	1	0
0x7A	0xE0	GEN2_DBYTE1	GEN2_DATA							
0x7A	0xE1	GEN2_DBYTE2								
0x7A	0xE2	GEN2_DBYTE3								
0x7A	0xE3	GEN2_DBYTE4								
0x7A	0xE4	GEN2_DBYTE5								
0x7A	0xE5	GEN2_DBYTE6								
0x7A	0xE6	GEN2_DBYTE7								
0x7A	0xE7	GEN2_DBYTE8								
0x7A	0xE8	GEN2_DBYTE9								
0x7A	0xE9	GEN2_DBYTE10								
0x7A	0xEA	GEN2_DBYTE11								
0x7A	0xEB	GEN2_DBYTE12								
0x7A	0xEC	GEN2_DBYTE13								
0x7A	0xED	GEN2_DBYTE14								
0x7A	0xEE	GEN2_DBYTE15								
0x7A	0xEF	GEN2_DBYTE16								
0x7A	0xF0	GEN2_DBYTE17								
0x7A	0xF1	GEN2_DBYTE18								
0x7A	0xF2	GEN2_DBYTE19								
0x7A	0xF3	GEN2_DBYTE20								
0x7A	0xF4	GEN2_DBYTE21								
0x7A	0xF5	GEN2_DBYTE22								
0x7A	0xF6	GEN2_DBYTE23								
0x7A	0xF7	GEN2_DBYTE24								
0x7A	0xF8	GEN2_DBYTE25								
0x7A	0xF9	GEN2_DBYTE26								
0x7A	0xFA	GEN2_DBYTE27								
0x7A	0xFB	GEN2_DBYTE28								
0x7A	0xFC	GEN2_DBYTE29								
0x7A	0xFD	GEN2_DBYTE30								
0x7A	0xFE	GEN2_DBYTE31								
Bit	Label	R/W	Description							Default
	GEN2_DATA	R/W	Generic Packet #2 Data Bytes.							

Appendices

The following sections describe how to use the HDMI Transmitter's functional block.

Area	Page	Topic
Audio	224	Handling Audio
	226	Handling DVD Audio
Video	228	Programming Video Input Mode and Video Output Mode
Control	252	Handling InfoFrames
	255	Operating DDC Master

Handling Audio

ENABLING AUDIO INPUTS

Audio input data is accepted from either the S/PDIF input or one or more I²S channels. The AUD_EN bit (register 0x7A:0x14) is logically ANDed with each channel enable bit (S/PDIF and I²S in register 0x7A:0x14). You can stop audio processing by writing 0 to AUD_EN. This stops the decoding of input samples so that no samples are written into the Audio FIFOs. When the FIFOs are emptied by HDMI formatting, the HDMI Transmitter stops sending audio packets on the HDMI link. NCTS packets continue to be sent as long as the Transmitter is in HDMI mode.

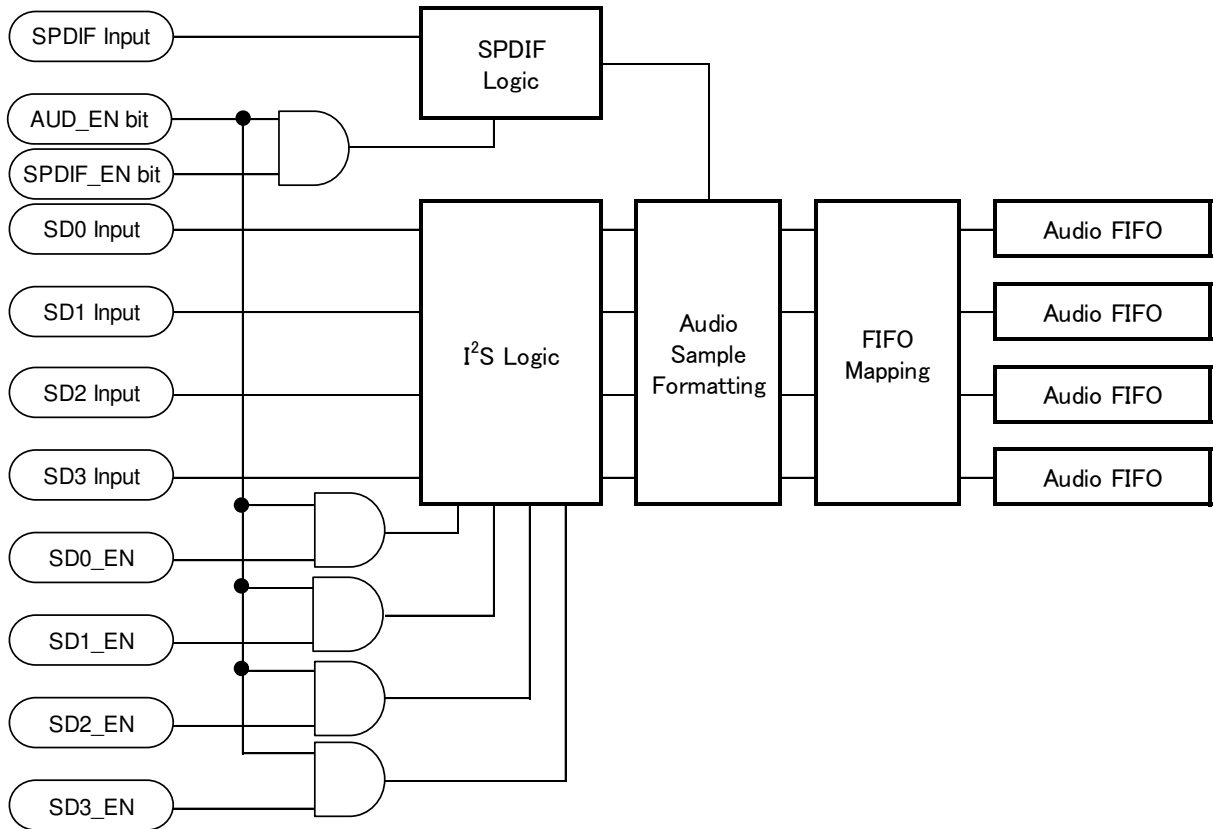

FIGURE 10. AUDIO INPUT CONTROL

ENCODING AUDIO ON HDMI

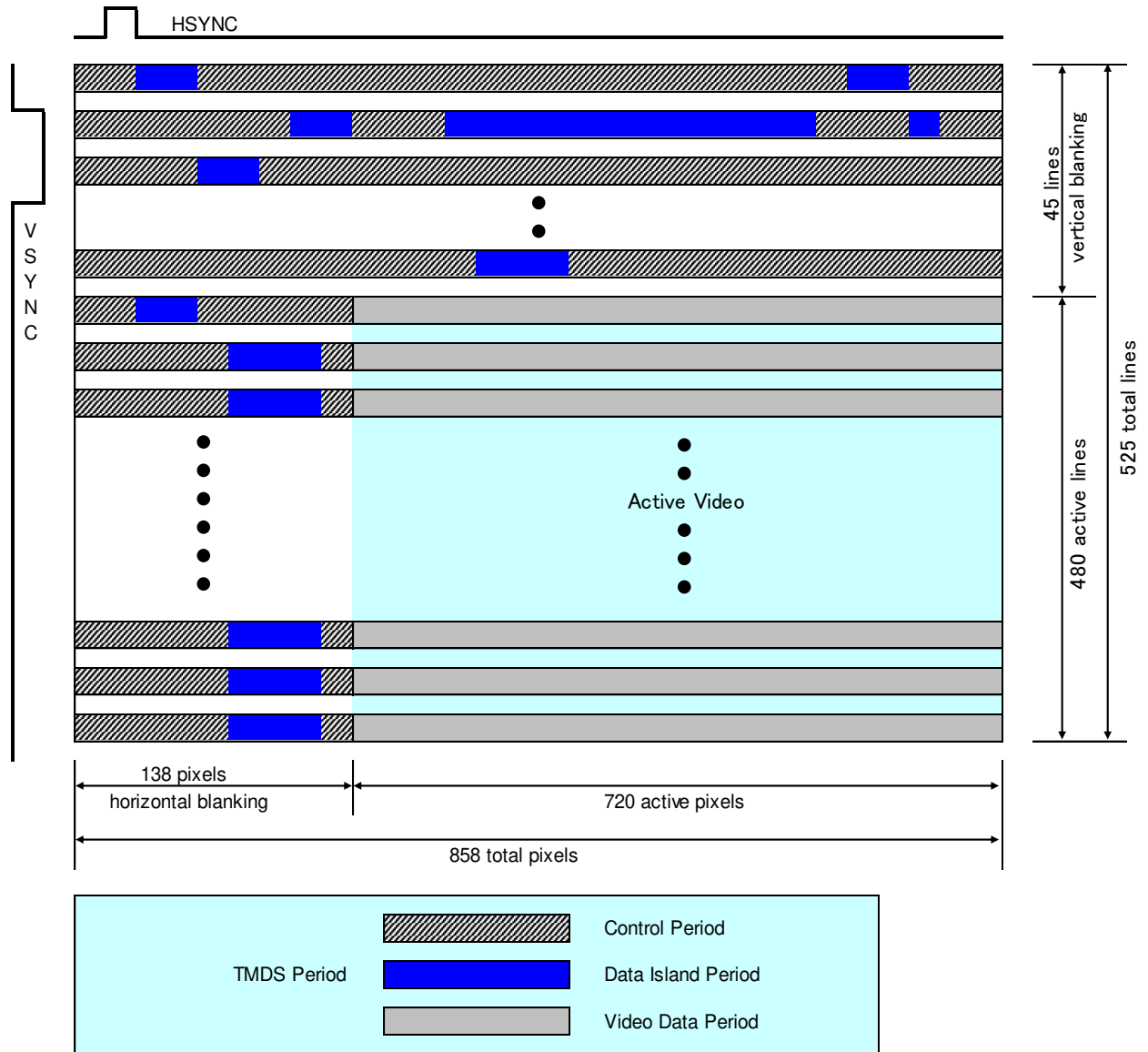

FIGURE 11. OVERVIEW OF HDMI OPERATING MODES IN 480P STREAM

Handling DVD Audio

SINK SUPPORT FOR AUDIO CONTENT PROTECTION

HDMI 1.1 describes three new packet types to support content protection for various audio formats: ACP, ISRC1, and ISRC2. The Source device transmits these packets, like other packets, as data islands during the vertical blanking time. The Source transmits these packets only if it recognizes the attached Sink or Repeater device as capable of receiving these packets as indicated in the EDID VSDB. The formats of the ACP, ISRC1, and ISRC2 packets are defined in HDMI 1.1, Sections 5.3.7 and 5.3.8.

The Sink and Repeater devices indicate support for these packets with a Vendor-Specific Data Block (VSDB) of length greater than 5 bytes in their E-EDID. This longer VSDB must be in the first 861B EDID timing extension, and includes bit fields new to HDMI 1.1. Older HDMI devices with 5-byte HDMI VSDBs indicate non-acceptance of ACP, ISRC1, or ISRC2 packets.

TRANSMITTING ACP PACKETS

The HDMI Transmitter allocates register space for four packets with a full-size payload of 31 data bytes. Each includes a 4-byte header with TYPE, VERSION, LENGTH, and CHECKSUM fields. The SPD and MPEG InfoFrames are defined in CEA-861B, although their lengths are less than 31 bytes. The HDMI Transmitter expands the register space for those InfoFrame Packets to accommodate any type of packet with 31 total bytes. In addition, the HDMI Transmitter provides for a *Generic Packet* and *Generic Packet #2*. With these four packets, the HDMI Transmitter can set up and transmit any four of the five defined packet types: SPD, MPEG, ACP, ISRC1, and ISRC2.

ISRC packets are used together to transmit International Standard Recording Code (ISRC) data from the Source to the Sink. When this information extends beyond 16 bytes, the ISRC_CONT field in the ISRC1 packet is set in the header and the remaining bytes are sent in the ISRC2 packet. The requirements for handling ISRC data are defined in the *DVD Specifications for Read-Only Disc, Part 4 (Version 1.0, March 1999, Annex B)*.

The Source device is required by HDMI 1.1 to transmit ACP packets within 300 milliseconds of changing to audio content, which requires transmission of content protection information and to repeat transmission of ACP packets at least every 300 milliseconds. If a Sink does not detect ACP packets for 600 milliseconds, it assumes that there is no content protection information needed. Details on transmission timing requirements for ACP and related packets are described in *HDMI 1.1 Section 9.3*.

To control transmission of ACP and related packets with the HDMI Transmitter, the packet registers must be loaded and enabled. If, in addition to ACP, ISRC1, and ISRC2, the Source also needs to send MPEG and SPD InfoFrames, then one set of packet registers must alternate between one of those packet payloads and the ACP or related payload. One possible flowchart for this process is shown in Figure 12. If all five types are sent, the last register set alternates between sending SPD and MPEG InfoFrames. See page 216 for register details on enabling and disabling packet transmission.

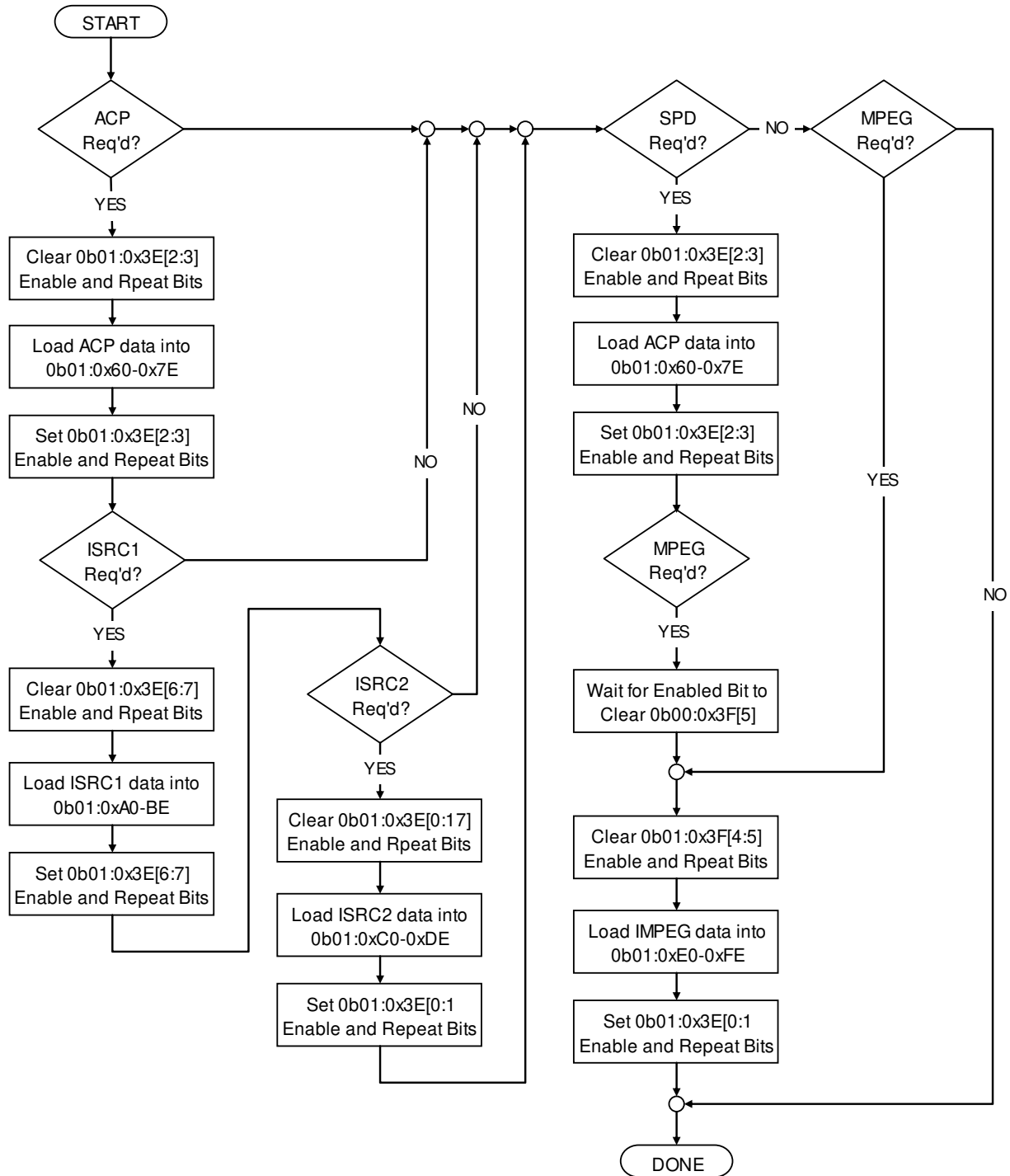

FIGURE 12. ACP PACKET CONTROL FLOWCHART

Before loading new data into a packet buffer, the firmware must check that the previous packet was sent.

Handling Video

PROGRAMMING VIDEO INPUT MODE AND VIDEO OUTPUT MODE

Specific registers in the HDMI Transmitter must be programmed according to the selection of input video bus mode and output video format.

The following notes apply to all tables on pages 233-247:

The DE parameters need to be programmed only when the DE Generator is enabled (0x72:0x33[6]).

The timings are based on EIA/CEA-861B specifications.

The parameters are application dependent. Consult the timing requirements of the Source device.

Set to 1 only when Y and C channels are each 12 bits wide. If these bus widths are less than 12 bits, set this bit to 0 and tie all unused pins to GND.

Shaded registers need not be programmed in this mode.

HBIT_TO_HSYNC, FIELD2_OFST, and VBIT_TO_VSYNC may differ depending on the porch timings in the input stream.

Set RANGE to 1 whenever converting YCbCr data and outputting full-range (0-255) RGB (PC mode) data across HDMI. When outputting limited-range (16-235) RGB (CE mode) data across the link, clear RANGE to 0.

Set WIDE_BUS to the number of bits per *input* video channel.

Set DITHER_MODE to the number of bits per *output* video channel supported by the Sink. By default, the HDMI Transmitter dithers the input (if DITHER 0x72:0x4A[5] is enabled) or truncates the input (if DITHER is disabled) to 8 bits.

Figure 13 diagrams the processing of video input data, leading to the TMDS encoding.

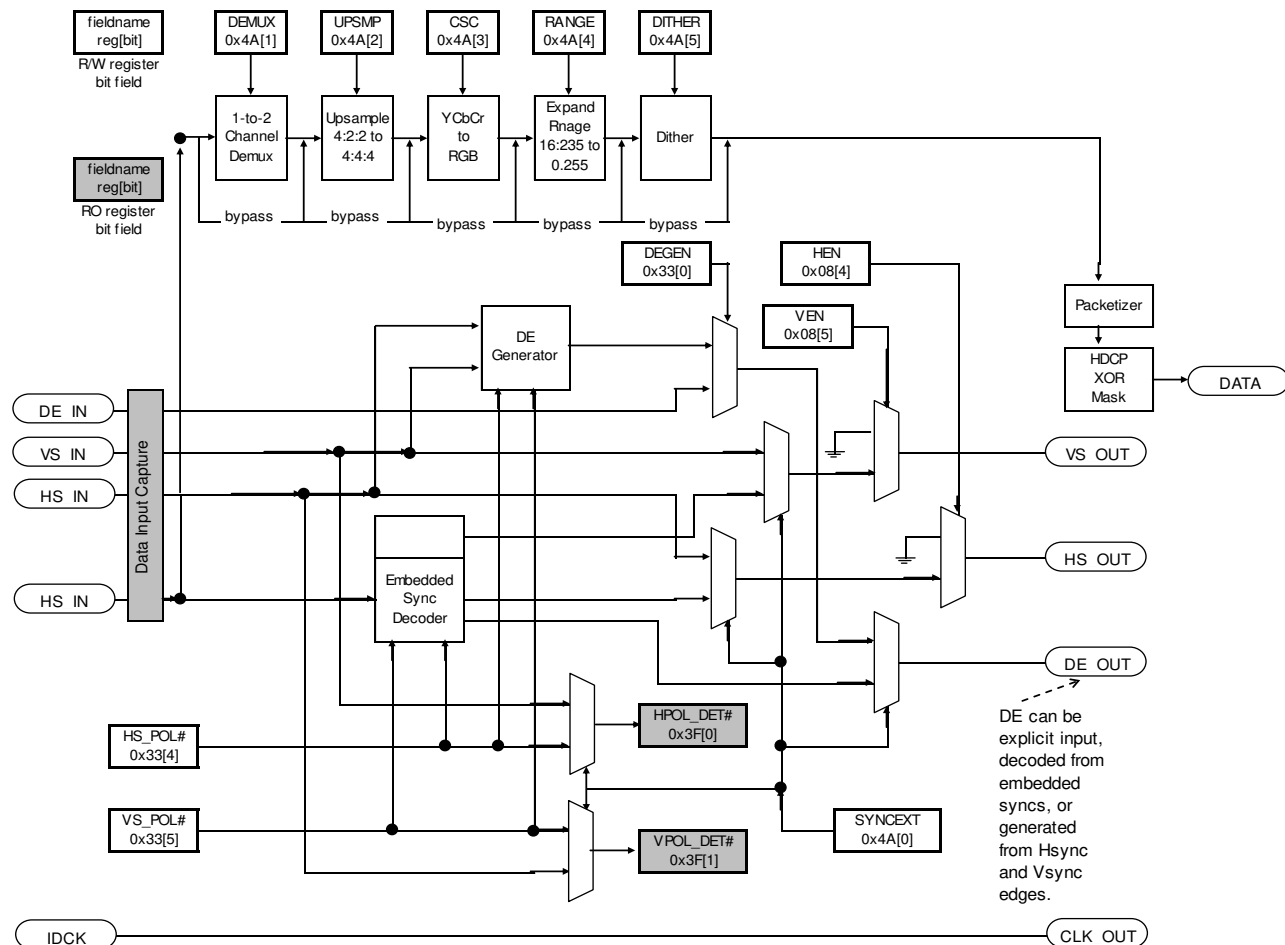

FIGURE 13. TRANSMITTER VIDEO DATA PROCESSING PATH

If Range Expand is enabled (0x72:0x4A[4]) and Color Space Conversion from YCbCr to RGB is enabled (0x72:0x4A[3]), then all 3 color channels are expanded by a ratio of 1.164.

If DITHER is enabled (0x72:0x4A[5]), the video output is *dithered* to the output width specified in DITHER_MODE (0x72:0x4A[7:6]). If DITHER is disabled, the video output is *truncated* to the output width specified in DITHER_MODE.

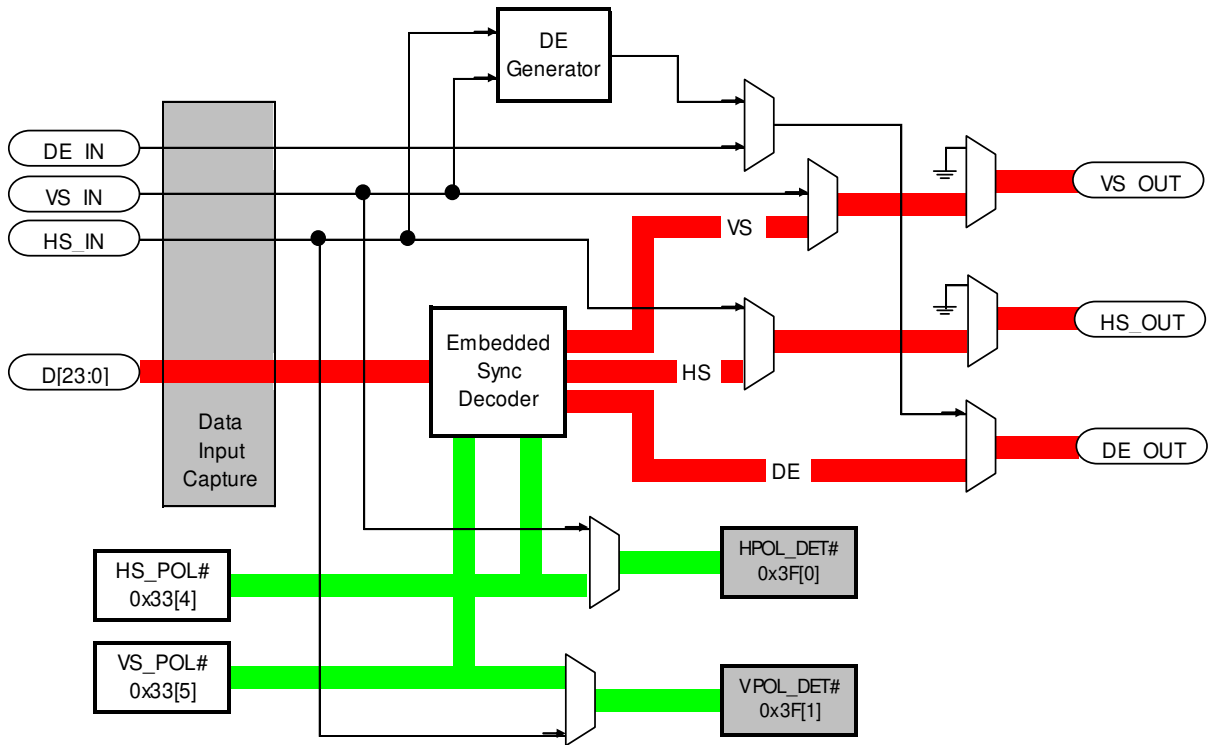

FIGURE 14. TRANSMITTER VIDEO DATA WITH SYNC DECODING

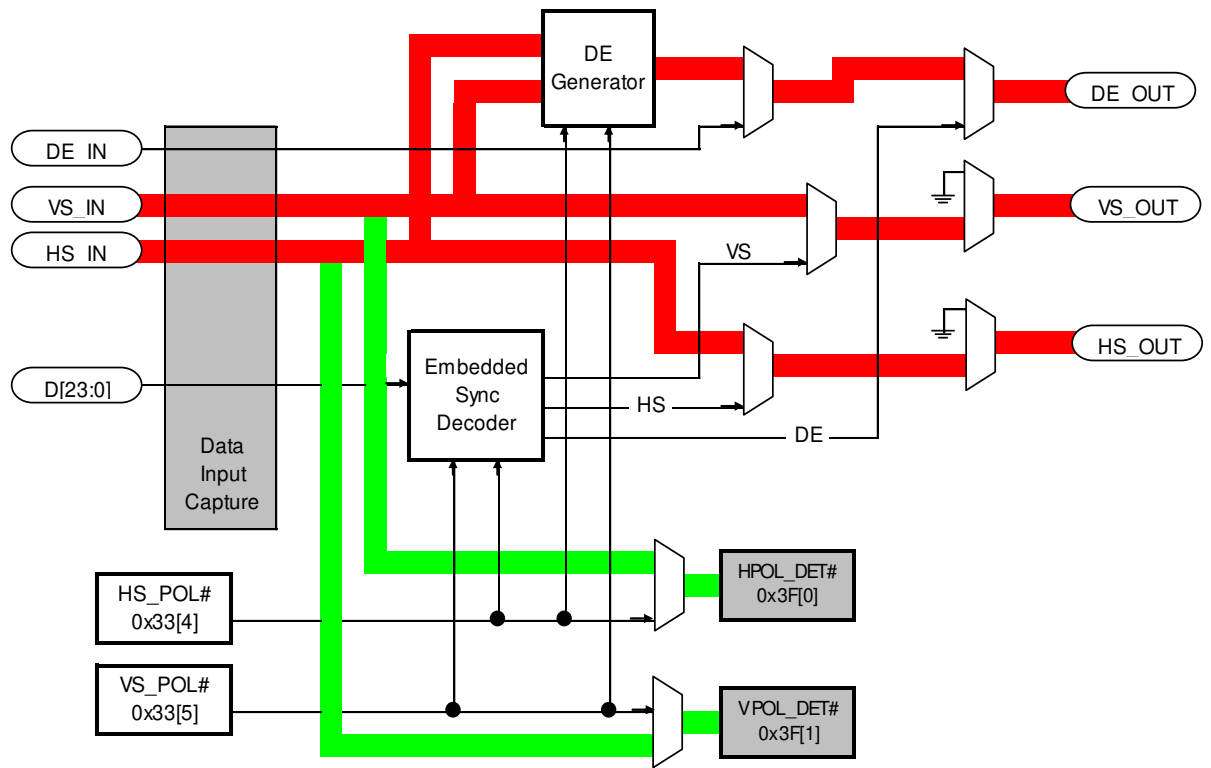

FIGURE 15. TRANSMITTER VIDEO DATA WITH DE GENERATOR FROM VS, HS

In Figure 14 and Figure 15, TMDS cores are generated using the signal paths colored red. The state of the VSYNC and HSYNC signals sent across the link can be read from VPOL_DET# and HPOL_DET#, as shown by the signal paths colored green.

HANDLING INTERLACED VIDEO

Interlaced video is more challenging for the HDMI Transmitter because the timing from VSYNC to pixel data changes from even to odd fields. Also, many MPEG sources do not provide standard timings in interlaced modes.

This must be corrected by the HDMI Transmitter so that the video timing across the HDMI link is compliant with CEA-861B. The registers listed in Table 21 are involved in decoding embedded syncs and generating DE for interlaced modes.

TABLE 21. REGISTERS USED TO HANDLE INTERFACED VIDEO

Field	Register	Address	Use
DE_ADJ#	IADJUST	0x72:0x3E	Video Interface Adjustment.
F2VADJ			
F2VOFST			
I_DET	POL_DETECT	0x72:0x3F	Video SYNC Polarity Detection.
VPOL_DET#			
HPOL_DET#			
HBIT_2H_SYNC	HBIT_2HSYNC	0x72:0x40-0x41	Video Hbit to HSYNC.
FIELD2_OFST	FLD2_HS_OFST	0x72:0x42-0x43	Video Field to HSYNC Offset.
HWIDTH	HWIDTH	0x72:0x44-0x45	Video HSYNC Length.
VBIT_TO_VSYNC	VBIT_TO_VSYNC	0x72:0x46	Video Vbit to VSYNC.
VWIDTH	VWIDTH	0x72:0x47	Video VSYNC Length.

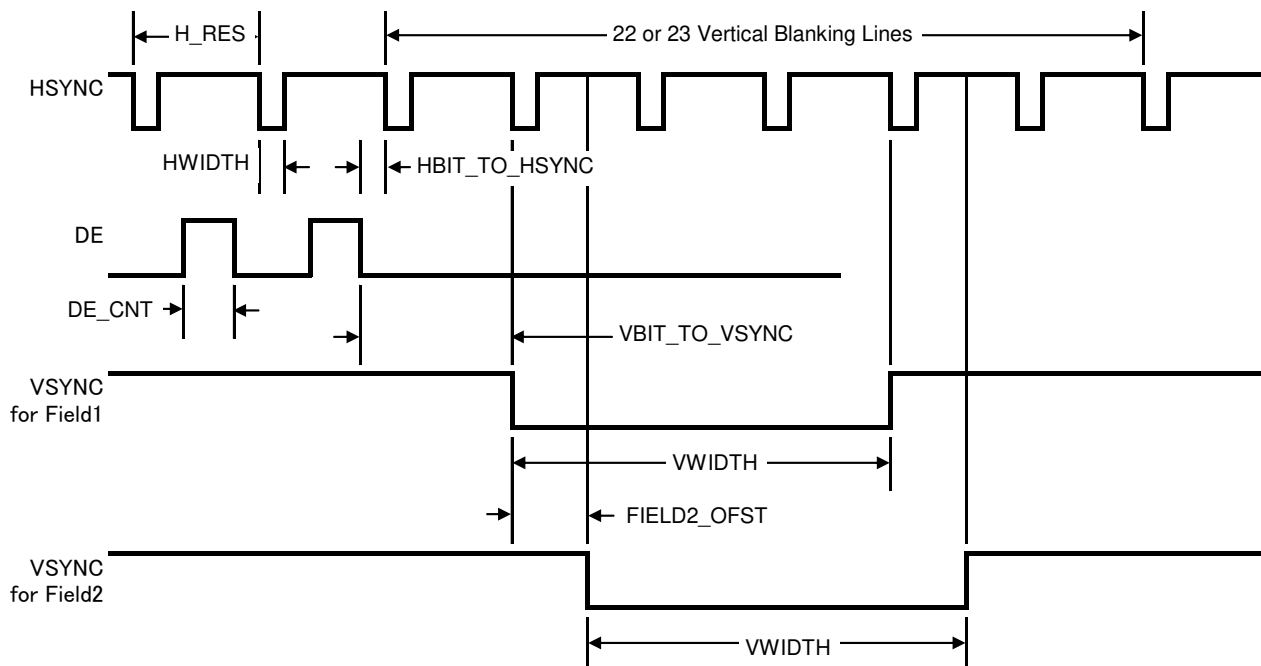

FIGURE 16. 480I EXAMPLE FOR HANDLING SYNCs

Note: Registers 0x72:0x40-0x46 are useful only when the input video uses 656 encoded syncs.

Summary of Video Processing Path Options

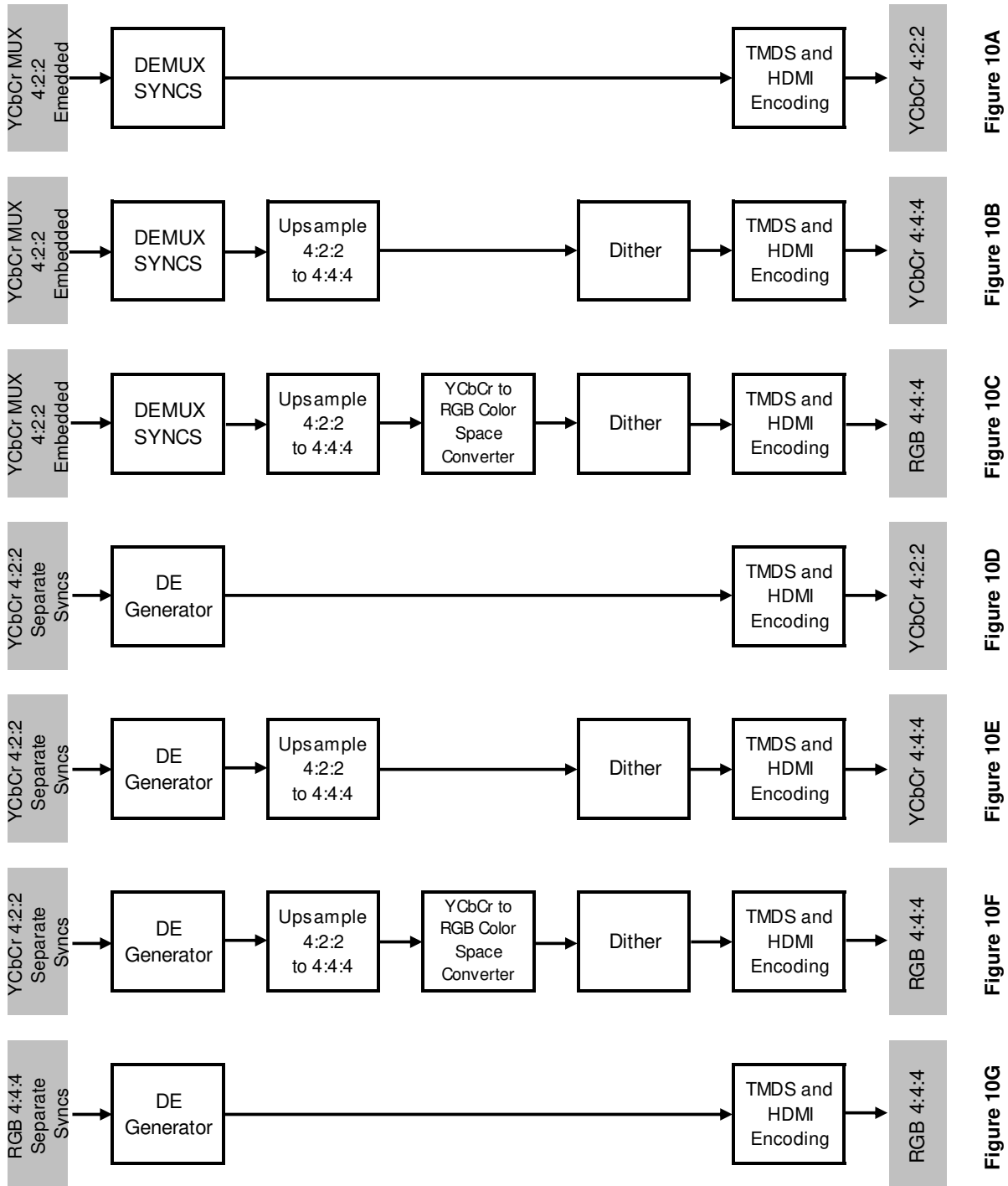

FIGURE 17. VIDEO INPUT TO VIDEO OUTPUT DATA FLOW

480i Input

480I MUXED YCBCR 4:2:2 EMBEDDED SYNC INPUT

Input Mode			Muxed YCbCr 4:2:2 Embedded Syncs			Notes	Page	
Output Mode			YCbCr 4:2:2	YCbCr 4:4:4	RGB			
Register								
DE_DLY	0x33 0x32	3:0 7:0				DE Delay	1,2,3	192
DE_TOP	0x34	6:0				DE Top	1,2,3	193
DE_CNT0	0x37 0x36	3:0 7:0				DE Count	1,2	193
DE_LIN	0x39 0x38	2:0 7:0				DE Lines	1,2	194
HS_POL#	0x33	4	1	1	1	HSYNC Polarity	2,3	193
VS_POL#	0x33	5	1	1	1	VSYNC Polarity	2,3	193
DE_GEN	0x33	6	0	0	0	DE_GEN Enable		193
HBIT_TO_HSYNC	0x41 0x40	1:0 7:0	00 0x13	00 0x13	00 0x13	HBit to HSYNC Delay	2	196
FIELD2_OFST	0x43 0x42	3:0 7:0	001 0xAD	001 0xAD	001 0xAD	Odd Field Offset	2	196
HWIDTH	0x45 0x44	1:0 7:0	000 0x3E	000 0x3E	000 0x3E	HSYNC Pulse Width	2	196
VBIT_TO_VSYNC	0x46	5:0	0x04	0x04	0x04	VBit to VSYNC Delay	2	196
VWIDTH	0x47	5:0	0x03	0x03	0x03	VSYNC Pulse Width	2	197
ICLK	0x48	1:0	00	00	00	Pixel Replication		197
CSCSEL	0x48	4			0	Color Space Select		197
EXTN	0x48	5	1	1	1	Extended Bit Mode	4	197
SYNCEXT	0x4A	0	1	1	1	Sync Extraction		198
DEMUX	0x4A	1	1	1	1	1-to-2 Chan Demux		198
UPSMP	0x4A	2	0	1	1	Upsampling		198
CSC	0x4A	3	0	0	1	Color Space Convert		198
RANGE	0x4A	4			1	Range Select	7	198
DITHER_MODE	0x4A	7:6				Bits per Output Video Channel	9	198
DITHER	0x4A	5	0	1	1	Dither Enable		198
Data Flow Diagram (Figure 17)			A	B	C			232

The video reconstructed by the HDMI Transmitter may not be compliant with CEA-861B timings, depending on the sync timings received from the Source device. See page 234 for register settings that enable both the sync decoder and the DE generator.

Refer to page 228 for additional notes.

480I MUXED YCBCR 4:2:2 EMBEDDED SYNC INPUT – FIXING FOR CEA-861B

Input Mode			Muxed YCbCr 4:2:2 Embedded Syncs				Notes	Page
Output Mode			YCbCr 4:2:2	YCbCr 4:4:4	RGB			
Register								
DE_DLY	0x33	3:0	0x0	0x0	0x0	DE Delay	1,2,3	192
	0x32	7:0	0x77	0x77	0x77			
DE_TOP	0x34	6:0	0x12	0x12	0x12	DE Top	1,2,3	193
DE_CNT	0x37	3:0	0x2	0x2	0x2	DE Count	1,2	193
	0x36	7:0	0xD0	0xD0	0xD0			
DE_LINC	0x39	2:0	0x0	0x0	0x0	DE Lines	1,2	194
	0x38	7:0	0xF0	0xF0	0xF0			
HS_POL#	0x33	4	1	1	1	HSYNC Polarity	2,3	193
VS_POL#	0x33	5	1	1	1	VSYNC Polarity	2,3	193
DE_GEN	0x33	6	1	1	1	DE_GEN Enable		193
HBIT_TO_HSYNC	0x41	1:0	00	00	00	HBit to HSYNC Delay	2, 6	196
	0x40	7:0	0x13	0x13	0x13			
FIELD2_OFST	0x43	3:0	001	001	001	Odd Field Offset	2, 6	196
	0x42	7:0	0xAD	0xAD	0xAD			
HWIDTH	0x45	1:0	000	000	000	HSYNC Pulse Width	2	196
	0x44	7:0	0x3E	0x3E	0x3E			
VBIT_TO_VSYNC	0x46	5:0	0x04	0x04	0x04	VBit to VSYNC Delay	2, 6	196
VWIDTH	0x47	5:0	0x03	0x03	0x03	VSYNC Pulse Width	2	197
ICLK	0x48	1:0	00	00	00	Pixel Replication		197
CSCSEL	0x48	4			0	Color Space Select		197
EXTN	0x48	5	1	1	1	Extended Bit Mode	4	197
SYNCEXT	0x4A	0	1	1	1	Sync Extraction		198
DEMUX	0x4A	1	1	1	1	1-to-2 Chan Demux		198
UPSMP	0x4A	2	0	1	1	Up sampling		198
CSC	0x4A	3	0	0	1	Color Space Convert		198
RANGE	0x4A	4			1	Range Select	7	198
DITHER_MODE	0x4A	7:6				Bits per Output Video Channel	9	198
DITHER	0x4A	5	0	1	1	Dither Enable		198
Data Flow Diagram (Figure 17)			A	B	C			232

The video reconstructed by the HDMI Transmitter may not be compliant with CEA-861B timings, depending on the sync timings received from the Source device. This table shows programming of both the sync decoder and the DE generator to correct porch timings to be CEA-861B compliant. See page 233 for register settings that enable only the sync decoder when the Source device provides compliant SAV/EAV timings.

Refer to page 228 for additional notes.

480I YCBCR 4:2:2 MUX YC SEPARATE SYNC INPUT

Input Mode			YCbCr 4:2:2 Mux YC Separate Syncs			Notes	Page	
Output Mode			YCbCr 4:2:2	YCbCr 4:4:4	RGB			
Register								
DE_DLY	0x33	3:0	0x0	0x0	0x0	DE Delay	1,2,3	192
	0x32	7:0	0x77	0x77	0x77			
DE_TOP	0x34	6:0	0x12	0x12	0x12	DE Top	1,2,3	193
DE_CNT	0x37	3:0	0x2	0x2	0x2	DE Count	1,2	193
	0x36	7:0	0xD0	0xD0	0xD0			
DE_LIN	0x39	2:0	0x0	0x0	0x0	DE Lines	1,2	194
	0x38	7:0	0xF0	0xF0	0xF0			
HS_POL#	0x33	4	1	1	1	HSYNC Polarity	2,3	193
VS_POL#	0x33	5	1	1	1	VSYNC Polarity	2,3	193
DE_GEN	0x33	6	1	1	1	DE_GEN Enable		193
HBIT_TO_HSYNC	0x41	1:0				HBit to HSYNC Delay	2	196
	0x40	7:0						
FIELD2_OFST	0x43	3:0				Odd Field Offset	2	196
	0x42	7:0						
HWIDTH	0x45	1:0				HSYNC Pulse Width	2	196
	0x44	7:0						
VBIT_TO_VSYNC	0x46	5:0				VBit to VSYNC Delay	2	196
VWIDTH	0x47	5:0				VSYNC Pulse Width	2	197
ICLK	0x48	1:0	00	00	00	Pixel Replication		197
CSCSEL	0x48	4			0	Color Space Select		197
EXTN	0x48	5	1	1	1	Extended Bit Mode	4	197
SYNCEXT	0x4A	0	0	0	0	Sync Extraction		198
DEMUX	0x4A	1	1	1	1			198
UPSMP	0x4A	2	0	1	1	Up sampling		198
CSC	0x4A	3	0	0	1	Color Space Convert		198
RANGE	0x4A	4			1	Range Select	7	198
DITHER_MODE	0x4A	7:6				Bits per Output Video Channel	9	198
DITHER	0x4A	5	0	1	1	Dither Enable		198
Data Flow Diagram (Figure 17)			D	E	F			232

Refer to page 228 for notes.

576i Input

576I YCBCR 4:2:2 EMBEDDED SYNC INPUT

Input Mode			YCbCr 4:2:2 Embedded Syncs			Notes	Page	
Output Mode			YCbCr	YCbCr	RGB			
Register			4:2:2	4:4:4	RGB			
DE_DLY	0x33	3:0				DE Delay	1,2,3	193
	0x32	7:0						
DE_TOP	0x34	6:0				DE Top	1,2,3	193
DE_CNT	0x37	3:0				DE Count	1,2	193
	0x36	7:0						
DE_LIN	0x39	2:0				DE Lines	1,2	194
	0x38	7:0						
HS_POL#	0x33	4	1	1	1	HSYNC Polarity	2,3	193
VS_POL#	0x33	5	1	1	1	VSYNC Polarity	2,3	193
DE_GEN	0x33	6	0	0	0	DE_GEN Enable		193
HBIT_2_HSYNC	0x41	1:0	00	00	00	HBit to HSYNC Delay	2	196
	0x40	7:0	0x0C	0x0C	0x0C			
FIELD2_OFST	0x43	3:0	001	001	001	Odd Field Offset	2	196
	0x42	7:0	0xB0	0xB0	0xB0			
HWIDTH	0x45	1:0	000	000	000	HSYNC Pulse Width	2	196
	0x44	7:0	0x3F	0x3F	0x3F			
VBIT_2_VSYNC	0x46	5:0	0x02	0x02	0x02	VBit to VSYNC Delay	2	196
VWIDTH	0x47	5:0	0x03	0x03	0x03	VSYNC Pulse Width	2	197
ICLK	0x48	1:0	01	01	01	Pixel Replication		197
CSCSEL	0x48	4			0	Color Space Select		197
EXTN	0x48	5	1	1	1	Extended Bit Mode	4	197
SYNCEXT	0x4A	0	1	1	1	Sync Extraction		198
DEMUX	0x4A	1	1	1	1	1-to-2 Chan Demux		198
UPSMP	0x4A	2	0	1	1	Up sampling		198
CSC	0x4A	3	0	0	1	Color Space Convert		198
RANGE	0x4A	4			1	Range Select	7	198
DITHER_MODE	0x4A	7:6				Bits per Output Video Channel	9	198
DITHER	0x4A	5	0	1	1	Dither Enable		198
Data Flow Diagram (Figure 17)			A	B	C			232

The video reconstructed by the HDMI Transmitter may not be compliant with CEA-861B timings, depending on the sync timings received from the Source device. See page 237 for register settings that enable both the sync decoder and the DE generator.

Refer to page 228 for additional notes.

576I YCBCR 4:2:2 EMBEDDED SYNC INPUT – FIXING FOR CEA-861B

Input Mode			YCbCr 4:2:2 Embedded Syncs				Notes	Page
Output Mode			YCbCr	YCbCr	RGB			
Register			4:2:2	4:4:4	RGB			
DE_DLY	0x33	3:0	0x1	0x1	0x1	DE Delay	1,2,3	193
	0x32	7:0	0x08	0x08	0x08			
DE_TOP	0x34	6:0	0x16	0x16	0x16	DE Top	1,2,3	193
DE_CNT	0x37	3:0	0x5	0x5	0x5	DE Count	1,2	193
	0x36	7:0	0xA0	0xA0	0xA0			
DE_LIN	0x39	2:0	0x1	0x1	0x1	DE Lines	1,2	194
	0x38	7:0	0x20	0x20	0x20			
HS_POL#	0x33	4	1	1	1	HSYNC Polarity	2,3	193
VS_POL#	0x33	5	1	1	1	VSYNC Polarity	2,3	193
DE_GEN	0x33	6	1	1	1	DE_GEN Enable		193
HBIT_2_HSYNC	0x41	1:0	00	00	00	HBit to HSYNC Delay	2, 6	196
	0x40	7:0	0x0C	0x0C	0x0C			
FIELD2_OFST	0x43	3:0	001	001	001	Odd Field Offset	2, 6	196
	0x42	7:0	0xB0	0xB0	0xB0			
HWIDTH	0x45	1:0	000	000	000	HSYNC Pulse Width	2	196
	0x44	7:0	0x3F	0x3F	0x3F			
VBIT_2_VSYNC	0x46	5:0	0x02	0x02	0x02	VBit to VSYNC Delay	2, 6	196
VWIDTH	0x47	5:0	0x03	0x03	0x03	VSYNC Pulse Width	2	197
ICLK	0x48	1:0	01	01	01	Pixel Replication		197
CSCSEL	0x48	4			0	Color Space Select		197
EXTN	0x48	5	1	1	1	Extended Bit Mode	4	197
SYNCEXT	0x4A	0	1	1	1	Sync Extraction		198
DEMUX	0x4A	1	1	1	1	1-to-2 Chan Demux		198
UPSMP	0x4A	2	0	1	1	Up sampling		198
CSC	0x4A	3	0	0	1	Color Space Convert		198
RANGE	0x4A	4			1	Range Select	7	198
DITHER_MODE	0x4A	7:6				Bits per Output Video Channel	9	198
DITHER	0x4A	5	0	1	1	Dither Enable		198
Data Flow Diagram (Figure 17)			A	B	C			232

The video reconstructed by the HDMI Transmitter may not be compliant with CEA-861B timings, depending on the sync timings received from the Source device. This table shows programming of both the sync decoder and the DE generator to correct porch timings to be CEA-861B compliant. See page 236 for register settings that enable only the sync decoder when the Source device provides compliant SAV/EAV timings.

Refer to page 228 for additional notes.

780p Input

720P RGB INPUT

Input Mode			RGB			Notes	Page	
Output Mode			YCbCr 4:2:2	YCbCr 4:4:4	RGB			
Register								
DE_DLY	0x33	3:0			0x1	DE Delay	1,2,3	193
	0x32	7:0			0x04			
DE_TOP	0x34	6:0			0x19	DE Top	1,2,3	193
DE_CNT	0x37	3:0			0x5	DE Count	1,2	193
	0x36	7:0			0x00			
DE_LIN	0x39	2:0			0x2	DE Lines	1,2	194
	0x38	7:0			0xD0			
HS_POL#	0x33	4			0	HSYNC Polarity	2,3	193
VS_POL#	0x33	5			0	VSYNC Polarity	2,3	193
DE_GEN	0x33	6			1	DE_GEN Enable		193
HBIT_2_HSYNC	0x41	1:0				HBIT to HSYNC Delay	2	196
	0x40	7:0						
FIELD2_OFST	0x43	3:0				Odd Field Offset	2	196
	0x42	7:0						
HWIDTH	0x45	1:0				HSYNC Pulse Width	2	196
	0x44	7:0						
VBIT_2_VSYNC	0x46	5:0				VBIT to VSYNC Delay	2	196
VWIDTH	0x47	5:0				VSYNC Pulse Width	2	197
ICLK	0x48	1:0			00	Pixel Replication		197
CSCSEL	0x48	4				Color Space Select		197
EXTN	0x48	5			0	Extended Bit Mode	4	197
SYNCEXT	0x4A	0			0	Sync Extraction		198
DEMUX	0x4A	1			0			198
UPSMP	0x4A	2			0	Up sampling		198
CSC	0x4A	3			0	Color Space Convert		198
RANGE	0x4A	4				Range Select		198
DITHER_MODE	0x4A	7:6				Bits per Output Video Channel	9	198
DITHER	0x4A	5			0	Dither Enable		198
Data Flow Diagram (Figure 17)					G			232

Refer to page 228 for notes.

720P YCBCR 4:4:4 SEPARATE SYNC INPUT

Input Mode			YCbCr 4:4:4 Separate Syncs			Notes	Page	
Output Mode			YCbCr 4:2:2	YCbCr 4:4:4	RGB			
Register								
DE_DLY	0x33	3:0		0x1	0x1	DE Delay	1,2,3	193
	0x32	7:0		0x04	0x04			
DE_TOP	0x34	6:0		0x19	0x19	DE Top	1,2,3	193
DE_CNT	0x37	3:0		0x5	0x5	DE Count	1,2	193
	0x36	7:0		0x00	0x00			
DE_LIN	0x39	2:0		0x2	0x2	DE Lines	1,2	194
	0x38	7:0		0xD0	0xD0			
HS_POL#	0x33	4		0	0	HSYNC Polarity	2,3	193
VS_POL#	0x33	5		0	0	VSYNC Polarity	2,3	193
DE_GEN	0x33	6		1	1	DE_GEN Enable		193
HBIT_2_HSYNC	0x41	1:0				HBit to HSYNC Delay	2	196
	0x40	7:0						
FIELD2_OFST	0x43	3:0				Odd Field Offset	2	196
	0x42	7:0						
HWIDTH	0x45	1:0				HSYNC Pulse Width	2	196
	0x44	7:0						
VBIT_2_VSYNC	0x46	5:0				VBit to VSYNC Delay	2	196
VWIDTH	0x47	5:0				VSYNC Pulse Width	2	197
ICLK	0x48	1:0		00	00	Pixel Replication		197
CSCSEL	0x48	4			1	Color Space Select		197
EXTN	0x48	5		0	0	Extended Bit Mode	4	197
SYNCEXT	0x4A	0		0	0	Sync Extraction		198
DEMUX	0x4A	1		0	0			198
UPSMP	0x4A	2		0	0	Up sampling		198
CSC	0x4A	3		0	1	Color Space Convert		198
RANGE	0x4A	4			1	Range Select	7	198
DITHER_MODE	0x4A	7:6		only		Bits per Output Video Channel	9	198
DITHER	0x4A	5		0	1	Dither Enable		198
Data Flow Diagram (Figure 17)			D	E	F			232

Refer to page 228 for notes.

720P YCBCR 4:2:2 SEPARATE SYNC INPUT

Input Mode			YCbCr 4:2:2 Separate Syncs			Notes	Page	
Output Mode			YCbCr 4:2:2	YCbCr 4:4:4	RGB			
Register								
DE_DLY	0x33	3:0	0x1	0x1	0x1	DE Delay	1,2,3	193
	0x32	7:0	0x04	0x04	0x04			
DE_TOP	0x34	6:0	0x19	0x19	0x19	DE Top	1,2,3	193
DE_CNT	0x37	3:0	0x5	0x5	0x5	DE Count	1,2	193
	0x36	7:0	0x00	0x00	0x00			
DE_LIN	0x39	2:0	0x2	0x2	0x2	DE Lines	1,2	194
	0x38	7:0	0xD0	0xD0	0xD0			
HS_POL#	0x33	4	0	0	0	HSYNC Polarity	2,3	193
VS_POL#	0x33	5	0	0	0	VSYNC Polarity	2,3	193
DE_GEN	0x33	6	1	1	1	DE_GEN Enable		193
HBIT_2_HSYNC	0x41	1:0				HBit to HSYNC Delay	2	196
	0x40	7:0						
FIELD2_OFST	0x43	3:0				Odd Field Offset	2	196
	0x42	7:0						
HWIDTH	0x45	1:0				HSYNC Pulse Width	2	196
	0x44	7:0						
VBIT_2_VSYNC	0x46	5:0				VBit to VSYNC Delay	2	196
VWIDTH	0x47	5:0				VSYNC Pulse Width	2	197
ICLK	0x48	1:0	00	00	00	Pixel Replication		197
CSCSEL	0x48	4			1	Color Space Select		197
EXTN	0x48	5	1	1	1	Extended Bit Mode	4	197
SYNCEXT	0x4A	0	0	0	0	Sync Extraction		198
DEMUX	0x4A	1	0	0	0			198
UPSMP	0x4A	2	0	1	1	Up sampling		198
CSC	0x4A	3	0	0	1	Color Space Convert		198
RANGE	0x4A	4			1	Range Select	7	198
DITHER_MODE	0x4A	7:6		only		Bits per Output Video Channel	9	198
DITHER	0x4A	5	0	1	1	Dither Enable		198
Data Flow Diagram (Figure 17)			D	E	F			232

Refer to page 228 for notes.

720P YCBCR 4:2:2 EMBEDDED SYNC INPUT

Input Mode			YCbCr 4:2:2 Embedded Syncs			Register	Note	Page
Output Mode			YCbCr 4:2:2	YCbCr 4:4:4	RGB			
DE_DLY	0x33	3:0				DE Delay	1,2,3	193
	0x32	7:0						
DE_TOP	0x34	6:0				DE Top	1,2,3	193
DE_CNT	0x37	3:0				DE Count	1,2	193
	0x36	7:0						
DE_LIN	0x39	2:0				DE Lines	1,2	194
	0x38	7:0						
HS_POL#	0x33	4	0	0	0	HSYNC Polarity	2,3	193
VS_POL#	0x33	5	0	0	0	VSYNC Polarity	2,3	193
DE_GEN	0x33	6	0	0	0	DE_GEN Enable		193
HBIT_2_HSYNC	0x41	1:0	00	00	00	HBit to HSYNC Delay	2	196
	0x40	7:0	0x6E	0x6E	0x6E			
FIELD2_OFST	0x43	3:0				Odd Field Offset	2	196
	0x42	7:0						
HWIDTH	0x45	1:0	0x0	0x0	0x0	HSYNC Pulse Width	2	196
	0x44	7:0	0x28	0x28	0x28			
VBIT_2_VSYNC	0x46	5:0	0x05	0x05	0x05	VBit to VSYNC Delay	2	196
VWIDTH	0x47	5:0	0x05	0x05	0x05	VSYNC Pulse Width	2	197
ICLK	0x48	1:0	00	00	00	Pixel Replication		197
CSCSEL	0x48	4			1	Color Space Select		197
EXTN	0x48	5	1	1	1	Extended Bit Mode	4	197
SYNCEXT	0x4A	0	1	1	1	Sync Extraction		198
DEMUX	0x4A	1	0	0	0			198
UPSMP	0x4A	2	0	1	1	Up sampling		198
CSC	0x4A	3	0	0	1	Color Space Convert		198
RANGE	0x4A	4			1	Range Select	7	198
DITHER_MODE	0x4A	7:6		only		Bits per Output Video Channel	9	198
DITHER	0x4A	5	0	1	1	Dither Enable		198
Data Flow Diagram (Figure 17)			A	B	C			232

The video reconstructed by the HDMI Transmitter may not be compliant with CEA-861B timings, depending on the sync timings received from the Source device. See page 242 for register settings that enable both the sync decoder and the DE generator.

Refer to page 228 for additional notes.

720P YCBCR 4:2:2 EMBEDDED SYNC INPUT – FIXING FOR CEA-861B

Input Mode			YCbCr 4:2:2 Embedded Syncs				Notes	Page
Output Mode			YCbCr 4:2:2	YCbCr 4:4:4	RGB			
Register								
DE_DLY	0x33	3:0	0x1	0x1	0x1	DE Delay	1,2,3	193
	0x32	7:0	0x04	0x04	0x04			
DE_TOP	0x34	6:0	0x19	0x19	0x19	DE Top	1,2,3	193
DE_CNT	0x37	3:0	0x5	0x5	0x5	DE Count	1,2	193
	0x36	7:0	0x00	0x00	0x00			
DE_LIN	0x39	2:0	0x2	0x2	0x2	DE Lines.	1,2	194
	0x38	7:0	0xD0	0xD0	0xD0			
HS_POL#	0x33	4	0	0	0	HSYNC Polarity	2,3	193
VS_POL#	0x33	5	0	0	0	VSYNC Polarity	2,3	193
DE_GEN	0x33	6	1	1	1	DE_GEN Enable		193
HBIT_2_HSYNC	0x41	1:0	00	00	00	HBit to HSYNC Delay	2, 6	196
	0x40	7:0	0x6E	0x6E	0x6E			
FIELD2_OFST	0x43	3:0				Odd Field Offset	2, 6	196
	0x42	7:0						
HWIDTH	0x45	1:0	0x0	0x0	0x0	HSYNC Pulse Width	2	196
	0x44	7:0	0x28	0x28	0x28			
VBIT_2_VSYNC	0x46	5:0	0x05	0x05	0x05	VBit to VSYNC Delay	2, 6	196
VWIDTH	0x47	5:0	0x05	0x05	0x05	VSYNC Pulse Width	2	197
ICLK	0x48	1:0	00	00	00	Pixel Replication		197
CSCSEL	0x48	4			1	Color Space Select		197
EXTN	0x48	5	1	1	1	Extended Bit Mode	4	197
SYNCEXT	0x4A	0	1	1	1	Sync Extraction		198
DEMUX	0x4A	1	0	0	0			198
UPSMP	0x4A	2	0	1	1	Up sampling		198
CSC	0x4A	3	0	0	1	Color Space Convert		198
RANGE	0x4A	4			1	Range Select	7	198
DITHER_MODE	0x4A	7:6		only		Bits per Output Video Channel	9	198
DITHER	0x4A	5	0	1	1	Dither Enable		198
Data Flow Diagram (Figure 17)			A	B	C			232

The video reconstructed by the HDMI Transmitter may not be compliant with CEA-861B timings, depending on the sync timings received from the Source device. This table shows programming of both the sync decoder and the DE generator to correct porch timings to be CEA-861B compliant. See page 241 for register settings that enable only the sync decoder when the Source device provides compliant SAV/EAV timings.

Refer to page 228 for additional notes.

1080i Input

1080I RGB INPUT

Input Mode			RGB			Notes	Page
Output Mode			YCbCr	YCbCr	RGB		
Register			4:2:2	4:4:4	RGB		
DE_DLY	0x33	3:0			0x0	DE Delay	1,2,3
	0x32	7:0			0xC0		
DE_TOP	0x34	6:0			0x14	DE Top	1,2,3
DE_CNT	0x37	3:0			0x7	DE Count	1,2
	0x36	7:0			0x80		
DE_LIN	0x39	2:0			0x2	DE Lines	1,2
	0x38	7:0			0x1C		
HS_POL#	0x33	4			0	HSYNC Polarity	2,3
VS_POL#	0x33	5			0	VSYNC Polarity	2,3
DE_GEN	0x33	6			1	DE_GEN Enable	193
HBIT_2_HSYNC	0x41	1:0				HBit to HSYNC Delay	2
	0x40	7:0					
FIELD2_OFST	0x43	3:0				Odd Field Offset	2
	0x42	7:0					
HWIDTH	0x45	1:0				HSYNC Pulse Width Fujitsu for	2
	0x44	7:0					
VBIT_2_VSYNC	0x46	5:0				VBit to VSYNC Delay	2
VWIDTH	0x47	5:0				VSYNC Pulse Width	2
ICLK	0x48	1:0			00	Pixel Replication	197
CSCSEL	0x48	4				Color Space Select	197
EXTN	0x48	5			0	Extended Bit Mode	4
SYNCEXT	0x4A	0			0	Sync Extraction	198
DEMUX	0x4A	1			0		198
UPSMP	0x4A	2			0	Up sampling	198
CSC	0x4A	3			0	Color Space Convert	198
RANGE	0x4A	4				Range Select	7
DITHER_MODE	0x4A	7:6				Bits per Output Video Channel	9
DITHER	0x4A	5			0	Dither Enable	198
Data Flow Diagram (Figure 17)					G		232

Refer to page 228 for notes.

1080I YCBCR 4:4:4 SEPARATE SYNC INPUT

Input Mode			YCbCr 4:4:4 Separate Syncs			Notes	Page	
Output Mode			YCbCr 4:2:2	YCbCr 4:4:4	RGB			
Register								
DE_DLY	0x33	3:0		0x0	0x0	DE Delay	1,2,3	193
	0x32	7:0		0xC0	0xC0			
DE_TOP	0x34	6:0		0x14	0x14	DE Top	1,2,3	193
DE_CNT	0x37	3:0		0x7	0x7	DE Count	1,2	193
	0x36	7:0		0x80	0x80			
DE_LIN	0x39	2:0		0x2	0x2	DE Lines	1,2	194
	0x38	7:0		0x1C	0x1C			
HS_POL#	0x33	4		0	0	HSYNC Polarity	2,3	193
VS_POL#	0x33	5		0	0	VSYNC Polarity	2,3	193
DE_GEN	0x33	6		1	1	DE_GEN Enable		193
HBIT_2_HSYNC	0x41	1:0				HBit to HSYNC Delay	2	196
	0x40	7:0						
FIELD2_OFST	0x43	3:0				Odd Field Offset	2	196
	0x42	7:0						
HWIDTH	0x45	1:0				HSYNC Pulse Width	2	196
	0x44	7:0						
VBIT_2_VSYNC	0x46	5:0				VBit to VSYNC Delay	2	196
VWIDTH	0x47	5:0				VSYNC Pulse Width	2	197
ICLK	0x48	1:0		00	00	Pixel Replication		197
CSCSEL	0x48	4			1	Color Space Select		197
EXTN	0x48	5		0	0	Extended Bit Mode	4	197
SYNCEXT	0x4A	0		0	0	Sync Extraction		198
DEMUX	0x4A	1		0	0			198
UPSMP	0x4A	2		0	0	Up sampling		198
CSC	0x4A	3		0	1	Color Space Convert		198
RANGE	0x4A	4			1	Range Select	7	198
DITHER_MODE	0x4A	7:6		only		Bits per Output Video Channel	9	198
DITHER	0x4A	5		0	1	Dither Enable		198
Data Flow Diagram (Figure 17)			D	E	F			232

Refer to page 228 for notes.

1080I YCBCR 4:2:2 SEPARATE SYNC INPUT

Input Mode			YCbCr 4:2:2 Separate Syncs			Notes	Page	
Output Mode			YCbCr 4:2:2	YCbCr 4:4:4	RGB			
Register								
DE_DLY	0x33	3:0	0x0	0x0	0x0	DE Delay	1,2,3	193
	0x32	7:0	0xC0	0xC0	0xC0			
DE_TOP	0x34	6:0	0x14	0x14	0x14	DE Top	1,2,3	193
DE_CNT	0x37	3:0	0x7	0x7	0x7	DE Count	1,2	193
	0x36	7:0	0x80	0x80	0x80			
DE_LIN	0x39	2:0	0x2	0x2	0x2	DE Lines	1,2	194
	0x38	7:0	0x1C	0x1C	0x1C			
HS_POL#	0x33	4	0	0	0	HSYNC Polarity	2,3	193
VS_POL#	0x33	5	0	0	0	VSYNC Polarity	2,3	193
DE_GEN	0x33	6	1	1	1	DE_GEN Enable		193
HBIT_2_HSYNC	0x41	1:0				HBit to HSYNC Delay	2	196
	0x40	7:0						
FIELD2_OFST	0x43	3:0				Odd Field Offset	2	196
	0x42	7:0						
HWIDTH	0x45	1:0				HSYNC Pulse Width	2	196
	0x44	7:0						
VBIT_2_VSYNC	0x46	5:0				VBit to VSYNC Delay	2	196
VWIDTH	0x47	5:0				VSYNC Pulse Width	2	197
ICLK	0x48	1:0	00	00	00	Pixel Replication		197
CSCSEL	0x48	4			1	Color Space Select		197
EXTN	0x48	5	1	1	1	Extended Bit Mode	4	197
SYNCEXT	0x4A	0	0	0	0	Sync Extraction		198
DEMUX	0x4A	1	0	0	0			198
UPSMP	0x4A	2	0	1	1	Up sampling		198
CSC	0x4A	3	0	0	1	Color Space Convert		198
RANGE	0x4A	4			1	Range Select	7	198
DITHER_MODE	0x4A	7:6		only		Bits per Output Video Channel	9	198
DITHER	0x4A	5	0	1	1	Dither Enable		198
Data Flow Diagram (Figure 17)			D	E	F			232

Refer to page 228 for notes.

1080I YCBCR 4:2:2 EMBEDDED SYNC INPUT

Input Mode			YCbCr 4:2:2 Embedded Syncs				Notes	Page
Output Mode			YCbCr 4:2:2	YCbCr 4:4:4	RGB			
Register								
DE_DLY	0x33 0x32	3:0 7:0				DE Delay	1,2,3	193
DE_TOP	0x34	6:0				DE Top	1,2,3	193
DE_CNT	0x37 0x36	3:0 7:0				DE Count	1,2	193
DE_LIN	0x39 0x38	2:0 7:0				DE Lines Confidential.	1,2	194
HS_POL#	0x33	4	0	0	0	HSYNC Polarity	2,3	193
VS_POL#	0x33	5	0	0	0	VSYNC Polarity	2,3	193
DE_GEN	0x33	6	0	0	0	DE_GEN Enable		193
HBIT_2_HSYNC	0x41 0x40	1:0 7:0	00 0x58	00 0x58	00 0x58	HBit to HSYNC Delay Provided to	2	196
FIELD2_OFST	0x43 0x42	3:0 7:0	0x4 0x4C	0x4 0x4C	0x4 0x4C	Odd Field Offset	2	196
HWIDTH	0x45 0x44	1:0 7:0	0x0 0x2C	0x0 0x2C	0x0 0x2C	HSYNC Pulse Width	2	196
VBIT_2_VSYNC	0x46	5:0	0x02	0x02	0x02	VBit to VSYNC Delay	2	196
VWIDTH	0x47	5:0	0x05	0x05	0x05	VSYNC Pulse Width	2	197
ICLK	0x48	1:0	00	00	00	Pixel Replication		197
CSCSEL	0x48	4			1	Color Space Select		197
EXTN	0x48	5	1	1	1	Extended Bit Mode	4	197
SYNCEXT	0x4A	0	1	1	1	Sync Extraction		198
DEMUX	0x4A	1	0	0	0			198
UPSMP	0x4A	2	0	1	1	Up sampling		198
CSC	0x4A	3	0	0	1	Color Space Convert		198
RANGE	0x4A	4			1	Range Select	7	198
DITHER_MODE	0x4A	7:6		only		Bits per Output Video Channel	9	198
DITHER	0x4A	5	0	1	1	Dither Enable		198
Data Flow Diagram (Figure 17)			A	B	C			232

The video reconstructed by the HDMI Transmitter may not be compliant with CEA-861B timings, depending on the sync timings received from the Source device. See page 247 for register settings that enable both the sync decoder and the DE generator.

Refer to page 228 for additional notes.

1080I YBCr 4:2:2 EMBEDDED SYNC INPUT – FIXING FOR CEA-861B

Input Mode			YCbCr 4:2:2 Embedded Syncs				Notes	Page
Output Mode			YCbCr 4:2:2	YCbCr 4:4:4	RGB			
Register								
DE_DLY	0x33	3:0	0x0	0x0	0x0	DE Delay	1,2,3	193
	0x32	7:0	0xC0	0xC0	0xC0			
DE_TOP	0x34	6:0	0x14	0x14	0x14	DE Top	1,2,3	193
DE_CNT	0x37	3:0	0x7	0x7	0x7	DE Count	1,2	193
	0x36	7:0	0x80	0x80	0x80			
DE_LIN	0x39	2:0	0x2	0x2	0x2	DE Lines	1,2	194
	0x38	7:0	0x1C	0x1C	0x1C			
HS_POL#	0x33	4	0	0	0	HSYNC Polarity	2,3	193
VS_POL#	0x33	5	0	0	0	VSYNC Polarity	2,3	193
DE_GEN	0x33	6	1	1	1	DE_GEN Enable		193
HBIT_2_HSYNC	0x41	1:0	00	00	00	HBit to HSYNC Delay	2, 6	196
	0x40	7:0	0x58	0x58	0x58			
FIELD2_OFST	0x43	3:0	0x4	0x4	0x4	Odd Field Offset	2, 6	196
	0x42	7:0	0x4C	0x4C	0x4C			
HWIDTH	0x45	1:0	0x0	0x0	0x0	HSYNC Pulse Width	2	196
	0x44	7:0	0x2C	0x2C	0x2C			
VBIT_2_VSYNC	0x46	5:0	0x02	0x02	0x02	VBit to VSYNC Delay	2, 6	196
VWIDTH	0x47	5:0	0x05	0x05	0x05	VSYNC Pulse Width	2	197
ICLK	0x48	1:0	00	00	00	Pixel Replication		197
CSCSEL	0x48	4			1	Color Space Select		197
EXTN	0x48	5	1	1	1	Extended Bit Mode	4	197
SYNCEXT	0x4A	0	1	1	1	Sync Extraction		198
DEMUX	0x4A	1	0	0	0			198
UPSMP	0x4A	2	0	1	1	Up sampling		198
CSC	0x4A	3	0	0	1	Color Space Convert		198
RANGE	0x4A	4			1	Range Select	7	198
DITHER_MODE	0x4A	7:6		only		Bits per Output Video Channel	9	198
DITHER	0x4A	5	0	1	1	Dither Enable		198
Data Flow Diagram (Figure 17)			A	B	C			232

The video reconstructed by the HDMI Transmitter may not be compliant with CEA-861B timings, depending on the sync timings received from the Source device. This table shows programming of both the sync decoder and the DE generator to correct porch timings to be CEA-861B compliant. See page 246 for register settings that enable only the sync decoder when the Source device provides compliant SAV/EAV timings.

Refer to page 228 for additional notes.

1080P YCBCR 4:4:4 SEPARATE SYNC INPUT

Input Mode			YCbCr 4:4:4 Separate Syncs					
Output Mode			YCbCr 4:2:2	YCbCr 4:4:4	RGB			
Register							Notes	Page
DE_DLY	0x33	3:0		0x0	0x0	DE Delay	1,2,3	193
	0x32	7:0		0xC0	0xC0			
DE_TOP	0x34	6:0		0x29	0x29	DE Top	1,2,3	193
DE_CNT	0x37	3:0		0x7	0x7	DE Count	1,2	193
	0x36	7:0		0x80	0x80			
DE_LIN	0x39	2:0		0x4	0x4	DE Lines	1,2	194
	0x38	7:0		0x38	0x38			
HS_POL#	0x33	4		0	0	HSYNC Polarity	2,3	193
VS_POL#	0x33	5		0	0	VSYNC Polarity	2,3	193
DE_GEN	0x33	6		1	1	DE_GEN Enable		193
HBIT_2_HSYNC	0x41	1:0				HBit to HSYNC Delay	2	196
	0x40	7:0						
FIELD2_OFST	0x43	3:0				Odd Field Offset	2	196
	0x42	7:0						
HWIDTH	0x45	1:0				HSYNC Pulse Width	2	196
	0x44	7:0						
VBIT_2_VSYNC	0x46	5:0				VBit to VSYNC Delay	2	196
VWIDTH	0x47	5:0				VSYNC Pulse Width	2	197
ICLK	0x48	1:0		00	00	Pixel Replication		197
CSCSEL	0x48	4			1	Color Space Select		197
EXTN	0x48	5		0	0	Extended Bit Mode	4	197
SYNCEXT	0x4A	0		0	0	Sync Extraction		198
DEMUX	0x4A	1		0	0			198
UPSMP	0x4A	2		0	0	Up sampling		198
CSC	0x4A	3		0	1	Color Space Convert		198
RANGE	0x4A	4			1	Range Select	7	198
DITHER_MODE	0x4A	7:6				Bits per Output Video Channel	9	198
DITHER	0x4A	5		0	1	Dither Enable		198
Data Flow Diagram (Figure 17)			D	E	F			232

Refer to page 228 for notes.

1080P YCBCR 4:2:2 SEPARATE SYNC INPUT

Input Mode			YCbCr 4:2:2 Separate Syncs				Notes	Page
Output Mode			YCbCr 4:2:2	YCbCr 4:4:4	RGB			
Register								
DE_DLY	0x33	3:0	0x0	0x0	0x0	DE Delay	1,2,3	193
	0x32	7:0	0xC0	0xC0	0xC0			
DE_TOP	0x34	6:0	0x29	0x29	0x29	DE Top	1,2,3	193
DE_CNT	0x37	3:0	0x7	0x7	0x7	DE Count	1,2	193
	0x36	7:0	0x80	0x80	0x80			
DE_LIN	0x39	2:0	0x4	0x4	0x4	DE Lines	1,2	194
	0x38	7:0	0x38	0x38	0x38			
HS_POL#	0x33	4	0	0	0	HSYNC Polarity	2,3	193
VS_POL#	0x33	5	0	0	0	VSYNC Polarity	2,3	193
DE_GEN	0x33	6	1	1	1	DE_GEN Enable		193
HBIT_2_HSYNC	0x41	1:0				HBit to HSYNC Delay	2	196
	0x40	7:0						
FIELD2_OFST	0x43	3:0				Odd Field Offset	2	196
	0x42	7:0						
HWIDTH	0x45	1:0				HSYNC Pulse Width	2	196
	0x44	7:0						
VBIT_2_VSYNC	0x46	5:0				VBit to VSYNC Delay	2	196
VWIDTH	0x47	5:0				VSYNC Pulse Width	2	197
ICLK	0x48	1:0	00	00	00	Pixel Replication		197
CSCSEL	0x48	4			1	Color Space Select		197
EXTN	0x48	5	1	1	1	Extended Bit Mode	4	197
SYNCEXT	0x4A	0	0	0	0	Sync Extraction		198
DEMUX	0x4A	1	0	0	0			198
UPSMP	0x4A	2	0	1	1	Up sampling		198
CSC	0x4A	3	0	0	1	Color Space Convert		198
RANGE	0x4A	4			1	Range Select	7	198
DITHER_MODE	0x4A	7:6				Bits per Output Video Channel	9	198
DITHER	0x4A	5	0	1	1	Dither Enable		198
Data Flow Diagram (Figure 17)			D	E	F			232

Refer to page 228 for notes.

1080P YCBCR 4:2:2 EMBEDDED SYNC INPUT

Input Mode			YCbCr 4:2:2 Embedded Syncs			Notes	Page	
Output Mode			YCbCr 4:2:2	YCbCr 4:4:4	RGB			
Register								
DE_DLY	0x33	3:0				DE Delay	1,2,3	193
	0x32	7:0						
DE_TOP	0x34	6:0				DE Top	1,2,3	193
DE_CNT	0x37	3:0				DE Count	1,2	193
	0x36	7:0						
DE_LIN	0x39	2:0				DE Lines Confidential.	1,2	194
	0x38	7:0						
HS_POL#	0x33	4	0	0	0	HSYNC Polarity	2,3	193
VS_POL#	0x33	5	0	0	0	VSYNC Polarity	2,3	193
DE_GEN	0x33	6	0	0	0	DE_GEN Enable		193
HBIT_2_HSYNC	0x41	1:0	00	00	00	HBit to HSYNC Delay Provided to	2	196
	0x40	7:0	0x58	0x58	0x58			
FIELD2_OFST	0x43	3:0				Odd Field Offset	2	196
	0x42	7:0						
HWIDTH	0x45	1:0	0x0	0x0	0x0	HSYNC Pulse Width	2	196
	0x44	7:0	0x2C	0x2C	0x2C			
VBIT_2_VSYNC	0x46	5:0	0x04	0x04	0x04	VBit to VSYNC Delay	2	196
VWIDTH	0x47	5:0	0x05	0x05	0x05	VSYNC Pulse Width	2	197
ICLK	0x48	1:0	00	00	00	Pixel Replication		197
CSCSEL	0x48	4			1	Color Space Select		197
EXTN	0x48	5	1	1	1	Extended Bit Mode	4	197
SYNCEXT	0x4A	0	1	1	1	Sync Extraction		198
DEMUX	0x4A	1	0	0	0			198
UPSMP	0x4A	2	0	1	1	Up sampling		198
CSC	0x4A	3	0	0	1	Color Space Convert		198
RANGE	0x4A	4			1	Range Select	7	198
DITHER_MODE	0x4A	7:6				Bits per Output Video Channel	9	198
DITHER	0x4A	5	0	1	1	Dither Enable		198
Data Flow Diagram (Figure 17)			A	B	C			232

The video reconstructed by the HDMI Transmitter may not be compliant with CEA-861B timings, depending on the sync timings received from the Source device. See page 251 for register settings that enable both the sync decoder and the DE generator.

Refer to page 228 for additional notes.

1080P YCBCR 4:2:2 EMBEDDED SYNC INPUT – FIXING FOR CEA-861B

Input Mode			YCbCr 4:2:2 Embedded Syncs				Notes	Page
Output Mode			YCbCr 4:2:2	YCbCr 4:4:4	RGB			
Register								
DE_DLY	0x33	3:0	0x0	0x0	0x0	DE Delay	1,2,3	193
	0x32	7:0	0xC0	0xC0	0xC0			
DE_TOP	0x34	6:0	0x29	0x29	0x29	DE Top	1,2,3	193
DE_CNT	0x37	3:0	0x7	0x7	0x7	DE Count	1,2	193
	0x36	7:0	0x80	0x80	0x80			
DE_LIN	0x39	2:0	0x4	0x4	0x4	DE Lines	1,2	194
	0x38	7:0	0x38	0x38	0x38			
HS_POL#	0x33	4	0	0	0	HSYNC Polarity	2,3	193
VS_POL#	0x33	5	0	0	0	VSYNC Polarity	2,3	193
DE_GEN	0x33	6	1	1	1	DE_GEN Enable		193
HBIT_2_HSYNC	0x41	1:0	00	00	00	HBit to HSYNC Delay	2, 6	196
	0x40	7:0	0x58	0x58	0x58			
FIELD2_OFST	0x43	3:0				Odd Field Offset	2, 6	196
	0x42	7:0						
HWIDTH	0x45	1:0	0x0	0x0	0x0	HSYNC Pulse Width	2	196
	0x44	7:0	0x2C	0x2C	0x2C			
VBIT_2_VSYNC	0x46	5:0	0x04	0x04	0x04	VBit to VSYNC Delay	2, 6	196
VWIDTH	0x47	5:0	0x05	0x05	0x05	VSYNC Pulse Width	2	197
ICLK	0x48	1:0	00	00	00	Pixel Replication		197
CSCSEL	0x48	4			1	Color Space Select		197
EXTN	0x48	5	1	1	1	Extended Bit Mode	4	197
SYNCEXT	0x4A	0	1	1	1	Sync Extraction		198
DEMUX	0x4A	1	0	0	0			198
UPSMP	0x4A	2	0	1	1	Up sampling		198
CSC	0x4A	3	0	0	1	Color Space Convert		198
RANGE	0x4A	4			1	Range Select	7	198
DITHER_MODE	0x4A	7:6				Bits per Output Video Channel	9	198
DITHER	0x4A	5	0	1	1	Dither Enable		198
Data Flow Diagram (Figure 17)			A	B	C			232

The video reconstructed by the HDMI Transmitter may not be compliant with CEA-861B timings, depending on the sync timings received from the Source device. This table shows programming of both the sync decoder and the DE generator to correct porch timings to be CEA-861B compliant. See page 250 for register settings that enable only the sync decoder when the Source device provides compliant SAV/EAV timings.

Refer to page 228 for additional notes.

Handling InforFrames

AVI INFORFRAMES

The following descriptions are adapted from Section 6.1 of the *EIA/CEA-861B Specification* and from Section 8.2.1 of the *HDMI 1.0 Specification*. AVI InfoFrame packets are enabled by AVI_EN and AVI_RPT in the Packet Buffer Control #1 Register (0x7A:0x3E), described on page 217.

Reg.		Bit Number								Notes	
		7	6	5	4	3	2	1	0		
0x40	0	Type Code	0x82								1
0x41	1	Version	0x02								2
0x42	2	Length	0x0D								3
0x43	3	Checksum								4	
0x44	4	Data Byte 1	0	Y1	Y0	A0	B1	B0	S1	S0	5,6
0x45	5	Data Byte 2	C1	C0	M1	M0	R3	R2	R1	R0	
0x46	6	Data Byte 3	0	0	0	0	0	0	SC1	SC0	
0x47	7	Data Byte 4	0	VIC6	VIC5	VIC4	VIC3	VIC2	VIC1	VIC0	
0x48	8	Data Byte 5	0	0	0	0	PR3	PR2	PR1	PR0	
0x49	9	Data Byte 6	Bar Info for Letterbox and Curtained Transmissions								
0x4A	10	Data Byte 7									
0x4B	11	Data Byte 8									
0x4C	12	Data Byte 9									
0x4D	13	Data Byte 10									
0x4E	14	Data Byte 11									
0x4F	15	Data Byte 12									
0x50	16	Data Byte 13									
0x51	17	Data Byte 14									
0x52	18	Data Byte 15									

Notes:

Although CEA-861B defines TYPE as 0x02, the HDMI Specification defines TYPE as 0x82 with bit 7 set.

VERSION 0x02 defines this as a CEA-861B AVI InfoFrame.

LENGTH should be set to 13 (0x0D). Additional data bytes are ignored. See the HDMI Specification, Section 8.2.1.

CHECKSUM is calculated so that the modulo-256 sum of {TYPE + VERSION + LENGTH + CHECKSUM + Data Bytes 1 to LENGTH} is zero. See the HDMI Specification, Section 5.3.5.

Shaded bits are RESERVED and are not to be set to other values.

See CEA-861B, Sections 6.1.2-6.1.3 for more details on the labeled fields in Data Bytes 1 through 13. The fields are summarized in Table 22, below.

1. CEA-861B defines only 13 data bytes. HDMI defines 27 data bytes. The HDMI Transmitter has 15 data byte registers. Load data byte 14 and 15 with 0x00.

TABLE 22 AVI INFORFRAME FIELD SETTINGS

Field				Definition
Y1		Y0		Color Space
0		0		RGB
0		1		YCbCr 4:2:2
1		0		YCbCr 4:4:4
1		1		Future
				A0
				Active Format Information Present
				0
				No format data present.
				1
				Active format identification data is present in the AVI InfoFrame.
B1		B0		Bar Info
0		0		Bar data not valid.
0		1		Vertical bar info valid.
1		0		Horizontal bar info valid.
1		1		Both vertical and horizontal bar info valid.
S1		S0		Scan Information
0		0		No data.
0		1		Over-scanned (television). Provided to
1		0		Under-scanned (computer).
1		1		Future
SC1		SC0		Non-Uniform Picture Scaling
0		0		No known non-uniform scaling.
0		1		Picture has been scaled horizontally.
1		0		Picture has been scaled vertically.
1		1		Picture has been scaled both horizontally and vertically.
C1		C0		Colorimetry
0		0		No data.
0		1		SMTPE 170M and ITU 601 (for standard definition TV)
1		0		ITU 709 (for advanced and high definition TV)
1		1		Future
M1		M0		Picture Aspect Ratio
0		0		No data.
0		1		4:3
1		0		16:9
1		1		Future
R3	R2	R1	R0	Active Format Aspect Ratio
1	0	0	0	Same as Picture Aspect Ratio (M1:M0 field).
1	0	0	1	4:3
1	0	1	0	16:9
1	0	1	1	14:9
other values				Per DVB AFD active_format field.

GENERAL CONTROL PACKETS

General Control packets control the flow of video and audio data across the HDMI link. The Control Packet is defined in Section 5.3.6 of the HDMI Specification. This data byte is controlled in the HDMI Transmitter with the CP_BYTE1 register (0x7A:0xDF), described on page 221. The Control Packet is transmitted only during the vertical blanking period, after the active edge of VSYNC.

To change the content of the CP_BYTE1 register, CP_EN must be zero. The firmware should keep CP_EN cleared until the desired value is written into SETAVM and CLRAVM. Then CP_EN and CP_RPT should be set to 1. (A more extensive explanation for Enable and Repeat bits is found on page 216.) The SETAVM bit and CLRAVM bit cannot both be set at the same time (see page 221). Because the Control Packet is synchronized to VSYNC, the action from SETAVM and CLRAVM takes effect immediately after the next VSYNC pulse.

SETAVM	CLRAVM	Action
0	0	Default setting after RESET#. Same action as SETAVM=0 with CLRAVM=1.
0	1	Allow pixel data and audio sample data to pass across the link. No muting.
1	0	Mute video and audio with 0x00 for all pixel data and send 0x00 for all audio packet data.
1	1	<i>NOT ALLOWED BY HDMI SPECIFICATION.</i>

When transmitting in DVI mode, setting SETAVM to 1 changes the video content to 0x00. CTL3 pulses stop at the next frame, so the HDMI Receiver stops decrypting and outputs the 0x00 data as a blank screen.

When a Link Integrity check fails in DVI mode, the HDMI Transmitter should stop the video signaling briefly before beginning a new authentication.

HANDLING AUDIO CONTENT PROTECTION (ACP) PACKETS

HDMI 1.1 defines new packets for handling content protection for audio. Refer to the explanations beginning on page 226.

Operating DDC Master

The HDMI Transmitter includes a logic block to drive the E-DDC bus, which supports a variety of I²C commands. The individual registers are described beginning on page 205. The speed of the I²C clock is determined by an internal oscillator in the HDMI Transmitter and is not dependent on, or a function of, any input pixel clock. The I²C frequency does not exceed 100 kHz.

Current Read

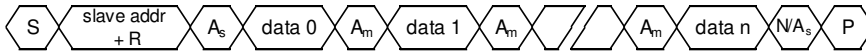

Sequential Read

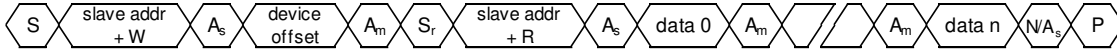

Enhanced DDC Read

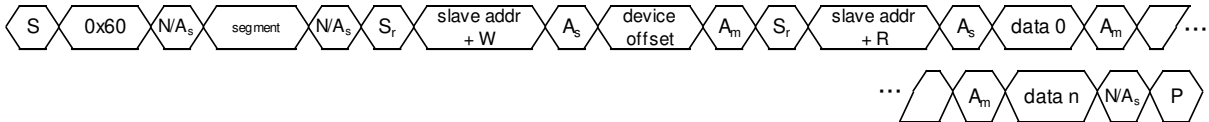

Sequential Write

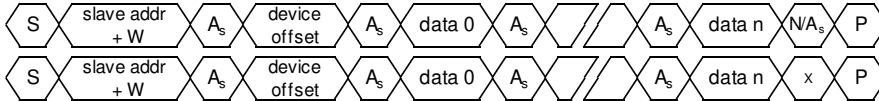

- S = start
- S_r = restart
- A_s = slave acknowledge
- A_m = master acknowledge
- N = no ack
- P = stop

FIGURE 18. SUPPORTED MASTER I²C TRANSACTIONS

Current Address Read – Reads from the last offset address so that no offset needs to be written to the slave. Multiple bytes may be read from consecutive addresses, which auto-increment in the slave with each ACK from the master.

Sequential Read – Reads from a specific start address, which is sent as a write command to the slave. Multiple bytes may be read from consecutive addresses. Although the FIFO in the HDMI Transmitter can hold only 16 bytes, the sequential read command may be of any length up to the 10-bit value in the DDC_COUNT register (0x72:0xF0-0xF1). A Stop bit is sent by the DDC master only when the entire DDC_COUNT has been completed.

Enhanced DDC Read – A special command defined by the VESA E-DDC Specification, which writes a segment address to a separate I²C device address, then sends an offset address to the slave device, and finally reads one or more data bytes beginning from address 128*segment+offset. Multiple bytes within the same segment may be read, as the slave auto-increments the offset with each ACK from the master. The segment register in the slave is reset at the end of each command. A NACK or ACK is required from the slave device if the segment is not zero, but is ignored if the segment is zero. Refer to the E-DDC Specification.

Sequential Write – Similar to the sequential read, this command sends one or more bytes to the slave, beginning at the explicit offset address. Multiple bytes may be written, as the slave auto-increments the address until the master sends a stop bit. Two command op codes are available to either wait for ACK/NACK on last byte or to ignore the ACK/NACK on last byte.

DEVICE ADDRESSES

The standardized device addresses for the E-DDC bus, as specified in the E-DDC standards, are listed in Table 23.

TABLE 23 DDC STANDARD DEVICE ADDRESSES

Device	Address
EDID PROM	0xA0
E-DDC Segment Address	0x60
Reserved	0x74

DDC READ OPERATION

The read command is setup by the micro when it loads values for the device address, the offset address, and the byte count. If the read command is to be an extended-DDC read, the segment address must also be loaded. After loading these values, the command register is loaded with the read command code.

The HDMI Transmitter uses a FIFO to hold data read across the DDC bus. Up to 16 bytes may be held in the FIFO, but as many as 1023 bytes may be read in one master DDC operation by setting the overall count in DDC_COUNT. The IN_PROG bit (0x72:0xF2[4]) is cleared when the last byte has been read. Figure 19 shows how to do a *short read* of 16 bytes or less. All N bytes can be read from the finished FIFO with one local I²C read command.

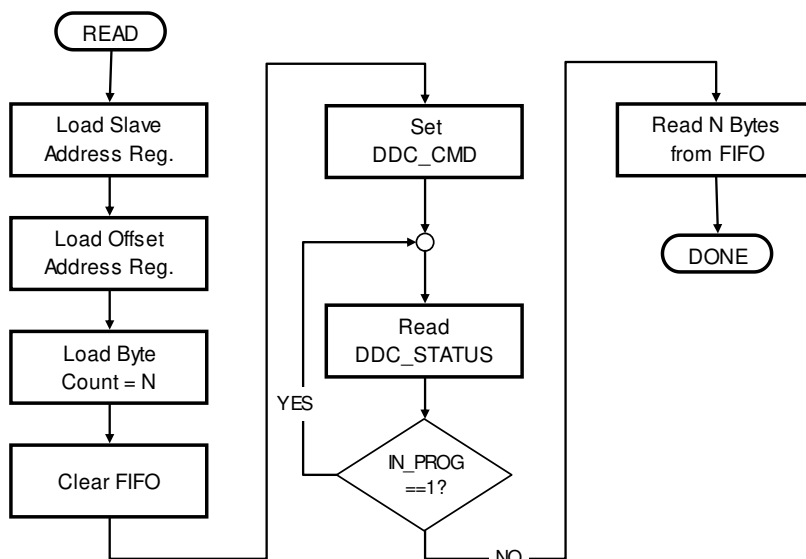

FIGURE 19. MASTER I2C READ COMMAND FLOWCHART #1

There are at least three methods for performing *long reads*. Choose the method suited to the RAM available in the microcontroller.

Figure 20 shows three methods for reading byte blocks through the FIFO. As soon as a data byte is read from the FIFO to the micro, the HDMI Transmitter resumes its read operation across the DDC bus and puts the next data byte from the DDC slave device into the FIFO.

	Advantages	Disadvantages
Method #1	Requires least amount of RAM in micro. Shortest flowchart.	Slow execution when f{DDC} is faster than f{local I ² C}, from high overhead of re-reading status and transferring one byte at a time.
Method #2	More efficient than Method #1 when f{DDC} is slower than f{local I ² C} by minimizing reads on local I ² C bus.	Requires most amount of RAM in micro. Flowchart complicated by reading remainder.
Method #3	Shorter flowchart than Method #2. Balances local I ² C and DDC operations. Optimizes read commands on local I ² C.	Requires more RAM than Method #2. No more efficient than Method #1 when f{local I ² C} is much faster than f{DDC}.

An abort command is used if the master device needs to stop the read command.

Read Single Bytes until Command Complete

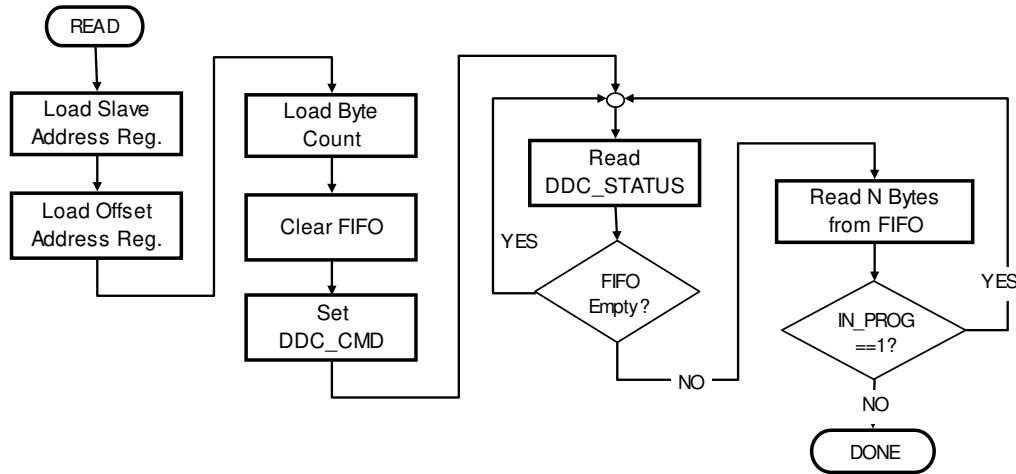

Read 16-Byte Blocks until Command Complete

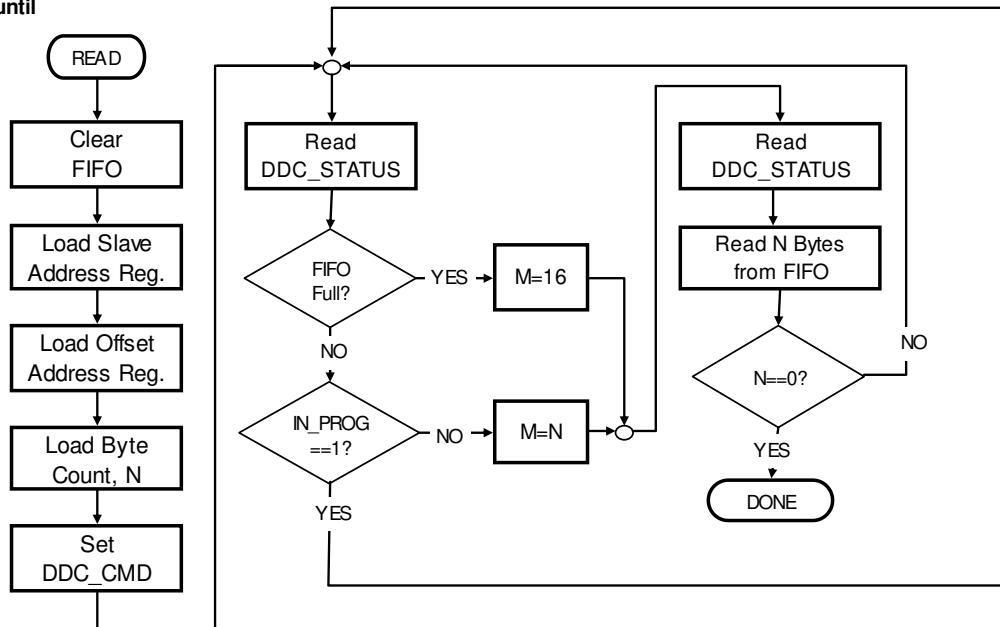

Read FIFO Content until Command Complete

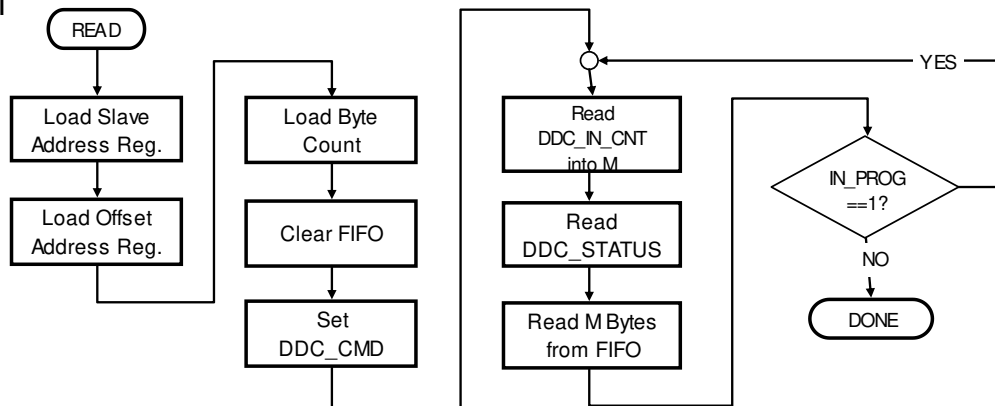

FIGURE 20. MASTER I2C READ COMMAND FLOWCHART #2

WRITE COMMAND

Write commands are similar to read commands. The FIFO must be written to by the micro before initiating the command, after resetting the FIFO to empty as described above. If fewer than 17 bytes are to be written to the DDC channel, the micro must only load the bytes to the FIFO and then write the DDC_CMD register with the write command code. If more than 16 bytes are to be written to the DDC channel, the micro must fill the FIFO, wait for it to begin sending (and not be full), then put the remaining bytes into the FIFO without overflowing it. *Since HDMI does not require a write of more than 16 bytes, such an operation is not described in this Programmer's Reference.*

Each master I²C operation begins with writes to several registers in the HDMI Transmitter. For a write command, the destination device address is followed with the offset address and the byte count. The micro must also clear the FIFO to an empty state before writing data to it. When the byte count is completed, the HDMI Transmitter automatically sends the stop bit onto the DDC bus. Figure 21 shows how to write up to 16 bytes from the micro to the DDC bus. All the data fits into the FIFO and so a multi-byte I²C write can be used from the micro to the HDMI Transmitter. The WRITE command is then issued to the DDC_CMD register and all data bytes are transferred across the DDC bus. Some type of timeout should be used when checking that the Master DDC module is available, either before starting a new command or before returning from the subroutine after beginning a command.

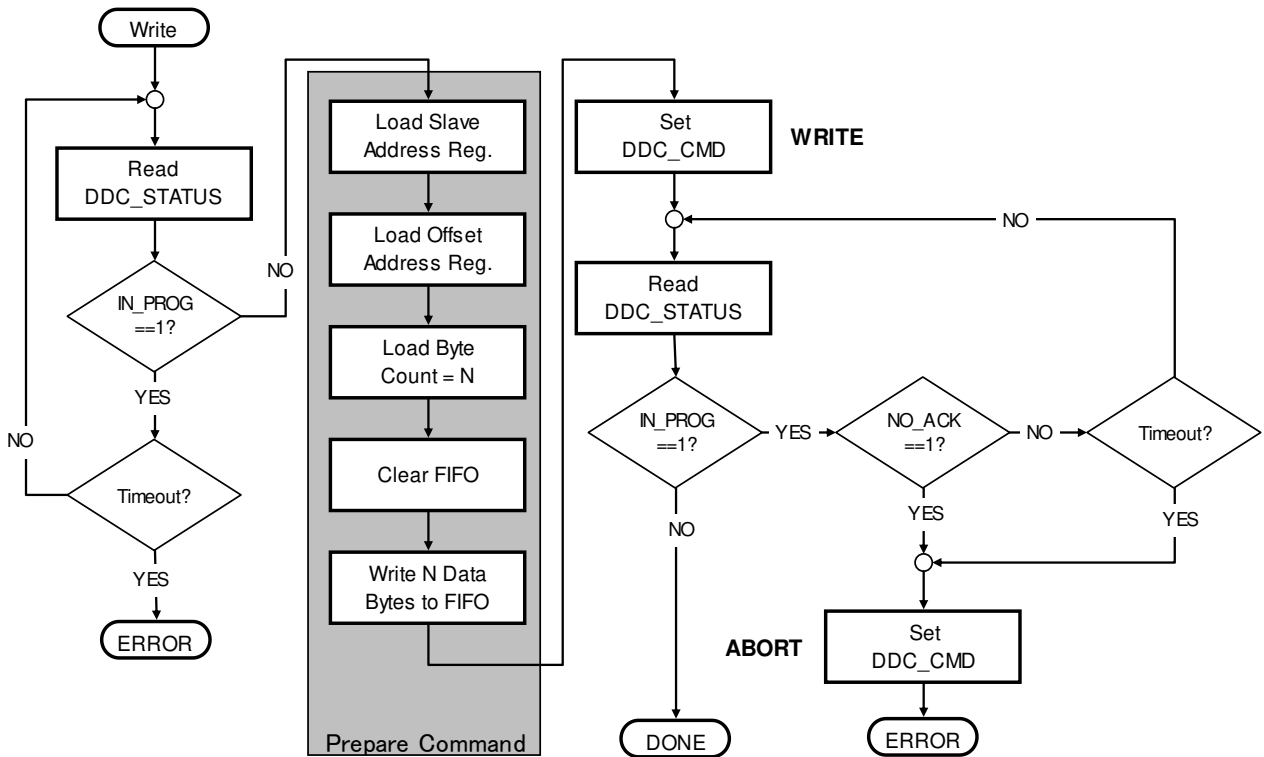

FIGURE 21. MASTER I²C WRITE COMMAND FLOWCHART #1

Figure 21 includes a check before beginning the write command to be certain that the Master DDC block is not already in use; and a check after triggering the write command to check for bus hangs. An abort command is used if the write command times out or fails to receive an ACK from the slave device.

ABORT COMMAND

A read or write command can be interrupted by the micro at any time by writing an Abort command to the DDC_CMD register (0x72:0xF3). The abort command issues a STOP condition, followed by nine SCK clocks, but only if a previous command is incomplete. Issuing the abort command when no other command is in progress causes no action on the DDC link. Firmware should allow for DDC bus hangs and include a timeout in the loop that waits for the completion of a write or read command. This can be done by setting up a watchdog timer with an interrupt service routine and aborting the DDC command if the timer expires. It can also be done by polling the DDC_STATUS byte and deciding that the command is stalled, then issuing an abort command.

Power Down Control

LOGIC BLOCKS AFFECTED BY POWER DOWN

The HDMI Transmitter provides various register bits to control power down of various sections of the chip. PD# is defined on page 189. PDIDCK#, PDOSC#, and PDTOT# are defined on page 215.

TABLE 24 POWER DOWN CONTROL BIT EFFECTS

PD#	PDIDCK#	PDOSC#	PDTOT#	Function	Note
X	X	X	0	Powers down everything. Equivalent to the combination of PD#=0 AND PDIDCK#=0 AND PDOSC#=0.	1
0	1	1	1	Powers down TMDS core and PLL. Digital logic is switching with an active IDCK. Registers are accessible via I ² C with exceptions listed Table 25.	2
1	0	1	1	Powers down internal digital clock tree.	3
1	1	0	1	Powers down internal ring oscillator. Disables internal read of KSV. Disables Master DDC block.	4,5

Notes on Table 24:

This combination delivers the lowest power consumption if input signals are switching.

An attached HDMI Receiver sees no switching clock or data and should react by disabling that HDMI input port until switching is detected again.

A quiet internal clock tree significantly reduces power consumption.

Master DDC can be used when PD#=0 or PDIDCK#=0, such as for reading EDID when the attached HDMI Receiver is not powered on.

Registers Affected by Power Down

The registers shown in Table 25 require PD#=1 AND PDIDCK#=1 AND PDOSC#=1 AND PDTOT#=1.

TABLE 25 REGISTERS AFFECTED BY PD BITS

Dev	Offset	Register	Dev	Offset	Register
0x7A	0x3E	PB_CTRL1	0x72	0x15	AN1
0x7A	0x3F	PB_CTRL2	0x72	0x16	AN2
0x72	0x0F	Reserved	0x72	0x17	AN3
0x72	0x10	BKSV1	0x72	0x18	AN4
0x72	0x11	BKSV2	0x72	0x19	AN5
0x72	0x12	BKSV3	0x72	0x1A	AN6
0x72	0x13	BKSV4	0x72	0x1B	AN7
0x72	0x14	BKSV5	0x72	0x1C	AN8

OSG for Display Path

Introduction

TW2880 OSG controller supports triple bitmap windows with 16 bit-per-pixel mode. Each OSG display window can support 8 sub-windows. OSG display engine supports upscale function. The powerful OSG memory writing engine allows less firmware effort. 16 bit color uses RGB 565 format, and it does not need color look-up-table. The input graphics from CPU can be 2 or 16 bit per pixel to reduce the amount of data writing by the CPU. The OSG writing engine automatically extends 2 bit pixel to 16 bit pixel format before writing into OSG graphic buffer in SDRAM. This is used for objects only with two colors such as fonts. The powerful OSG memory writing engine supports CPU write, block transfer, and block fill mode. When writing to SDRAM, OSG engine also supports color conversion and selective color overwrite. Graphic data are save in the external SDRAM. The maximum size can be 8192x8192 pixels depends on SDRAM size.

Features

- Triple windows bitmap OSG
- Each OSG window has 8 sub-windows
- Window upscale
- Three write modes: written directly by host, block transfer and block fill by hardware
- Bitmap compression for reduced access bandwidth
- Color selective overwrite
- Bit extension from 2bit to 16 bit
- 4 Color conversion
- Blinking, transparent, alpha blending control when displaying on screen
- Hardware BitBit unit
- 1K byte buffer for host write
- Host can write data using 8bit or 16bit
- Big endian and little endian mode

For three write mode, the following table shows which features they can support.

MODE	DE-COMPRESS	LINEAR BUFFER	BIT EXTENSION	SELECTIVE OVERWRITE / BITBLT	COLOR CONVERSION
Host write	Y	Y	Y	Y	Y
Block transfer	N	Y	N	Y	Y
Block fill	N	N	N	N	N

OSG Graphic Buffer

MEMORY DIAGRAM

The following picture shows the OSG memory in SDRAM and some related registers.

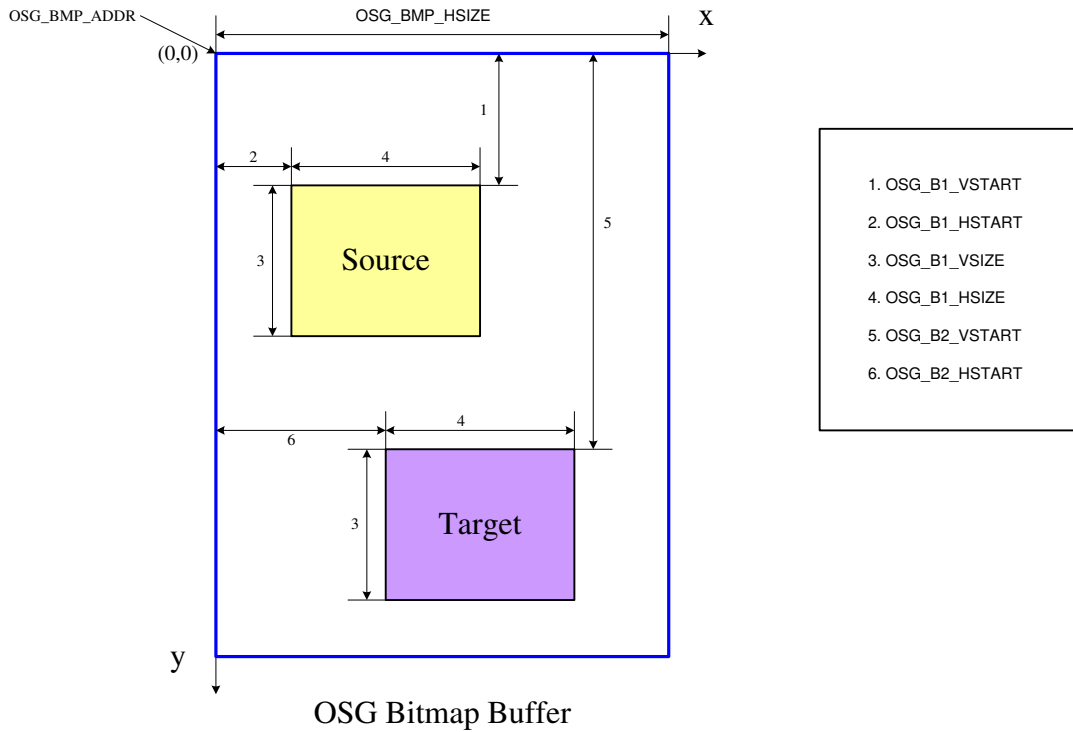

BITMAP BUFFER

TW2880 on screen display is a bitmapped based OSG controller. Each pixel in the OSG window corresponds to a pixel data in the bitmap buffer of 16 bit in external SDRAM memory. The bitmap buffer size supports up to a maximum size of 4096x4096 pixels. The horizontal pixel size is controlled by the OSG_BMP_HSIZE register. The bitmap buffer starting address in SDRAM is controlled by OSG_BMP_ADDR register.

Since video images are saved in upper side of SDRAM, Bitmap Buffer is not saved in continuous physical address in SDRAM. OSG_BMP_ADDR is the start address of each OSG bank in SDRAM. Firmware does not need to know the physical address of an object. Hardware will automatically be calculated physical address of bitmap buffer. Firmware can treat bitmap buffer as a continuous address space.

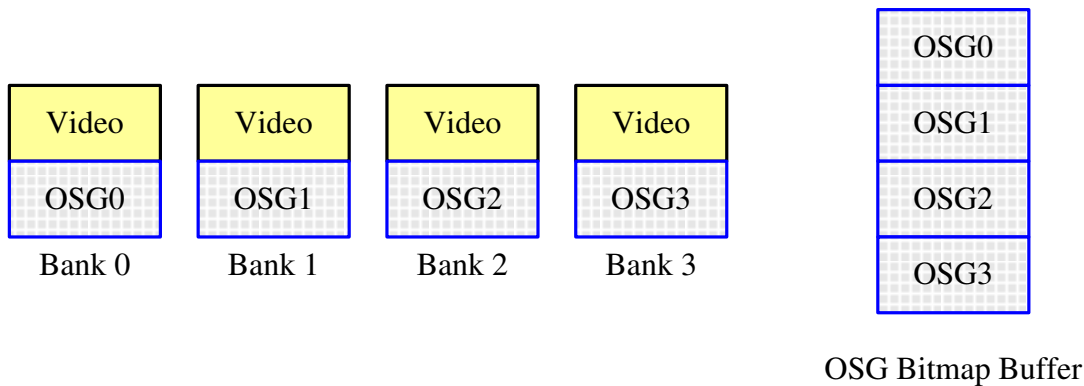

WRITE MEMROY BY HOST

With this method, CPU download original bitmap to bitmap buffer or linear buffer. To use this mode, first select mode by setting register OSG_WR_MODE to 2'b00 and other control register bits. If bitmap buffer is used, horizontal start address (OSG_B2_HSTART) and vertical start address (OSG_B2_VSTART) of target memory location need to be programmed. Both for bitmap buffer and linear buffer, horizontal size (OSG_B1_HSIZE) and vertical size (OSG_B1_VSIZE) need to be programmed. In this mode, data compression, color conversion, selective overwrite and pixel bit extension are all supported. After all registers are ready, host write OSG_WR_START command. After this command is triggered, host continuous write data to OSG_HOST_DATA. If internal memory is full, hardware will generate a wait signal to host. Host will stop running. Host can also read status register. The number of byte written need to be consistent with the setting.

BLOCK TRANSFER

CPU can move a rectangular area from one location to another location. Source can be in bitmap buffer or linear buffer. Target can only be bitmap buffer. It simply specifies the source / destination location and the object size, hardware performs the block transfer automatically. To use this mode, first select mode by setting register OSG_WR_MODE to 2'b01, and configure all the necessary registers such as source location and size and target location and size. After that, host write OSG_WR_START command. In this mode, compression and bit expanding are not supported, color conversion and selective overwrite are supported.

BLOCK FILL

In this mode, CPU specifies a command to fill a rectangular block with a single color and then the hardware automatically fill the specified area with a single color. This allows the CPU to easily fill the background color. To use this mode, first select the mode by setting register OSG_WR_MODE to 2'b10, and configures all the necessary registers such as destination register, then start block fill by setting register OSG_WR_START to 1. Data compression, color conversion, selective overwrite, pixel bit extension and linear buffer are not supported. The color is set by register OSG_FILL_COLOR.

BITBLT

TW2880 also supports BitBlit function. There are 256 operations in BitBlit. It is an extension for block transfer.

BitBlit function need three objects: source, destination and mask. The result is written to destination. It can be written as a function equation: $\text{destination} = \text{bitblit}(\text{mask}, \text{destination}, \text{source})$.

In this function, destination is one bit of destination pixel, source is the same bit of destination pixel, mask is same bit of destination pixel.

(mask, destination, source) generate one 3 bit data. For example if mask is 1, destination is 0 and source is 0. The (mask, destination, source) is 3'b100 which is 4. Then BitBlit bit 4 is the result. Three bit generate data from 0 to 7. Then BitBlit data bit 0 to 7 is the result because BitBlit operation code is 8 bit value.

For example, BitBlit operation code is $0xCA = 11001010b$

We can get the look up table:

MASK	DESTINATION	SOURCE	RESULT
0	0	0	0
0	0	1	1
0	1	0	0
0	1	1	1
1	0	0	0
1	0	1	0
1	1	0	1
1	1	1	1

You will find result is $\text{destination} = \text{mask} \ ? \ \text{destination} : \text{source}$.

0x0001, 0x0002, 0x0003, 0x0004, 0x0004, 0x0004, 0x0004, 0x0004, 0x0004.

Then compressed data string is:

0 0000000000000001 0 000000000000010 0 000000000000011 0 000000000000100 1 00000101

The count number is 5 in this case. Count number is the repeated data number not include the first data.

If count number is 256 in 8-bit case, then count is set to "0". If count number is more than 256, than put several count packets. For example, uncompressed data stream is:

0x0001, 0x0002, 0x0003, 0x0004, 0x0004, 0x0004, 0x0004, 0x0004, 0x0004, ..., 0x0004

In this case, total amount of 0x0004 is 400, then first count should be 0, second count should be 143. Or first count plus second count should be 399.

PIXEL BIT EXTENSION

Although the bitmap buffer is 16 bit per pixel, input pixel from CPU can be 2 bit or 16 bit. When 2 bit format is enabled, hardware will automatically convert 2 bit color to 16 bit color. Here "00" is converted to OSG_CON_TAR1, "01" is converted to OSG_CON_TAR2, "10" is converted to OSG_CON_TAR3, and "11" is converted to OSG_CON_TAR4,. Data written to SDRAM is always 16 bit. To enable this mode, set register OSG_PIXEL_BIT to high. This mode is used for simple color object like font. It will save a lot of CPU memory. It is only used in host write memory mode.

COLOR CONVERSION

Before data are written into SDRAM, color conversion can be enabled by setting bit OSG_COLCON_EN to high. This is used in direct host write and block transfer mode. Four color registers need to be programmed. Source color OSG_CON_SRC1 will be converted to target color OSG_CON_TAR1. Source color OSG_CON_SRC2 will be converted to target color OSG_CON_TAR2.

SELECTIVE OVERWRITE

When writing into the buffer through host write, block transfer. The pixels with color (OSG_OVWR_COLOR) can be specified as transparent pixels so that they will not be written into the buffer. There are four overwrite color can be used. For example, the font background will not be written and allows only the foreground pixels being written. To use this selective pixel writing, set register OSG_OVWR_MODE to 2'b00. This is one of the BitBlit operation.

PIXEL OPERATION SEQUENCE

The sequence of data operation is:

de-compression

bit extension

color conversion

BitBlit (selective overwrite)

Bitmap Buffer Display

TW2880 supports three OSG windows. The contents showed on screen are based on Bitmap Buffer. The following picture shows the bitmap buffer and related display registers.

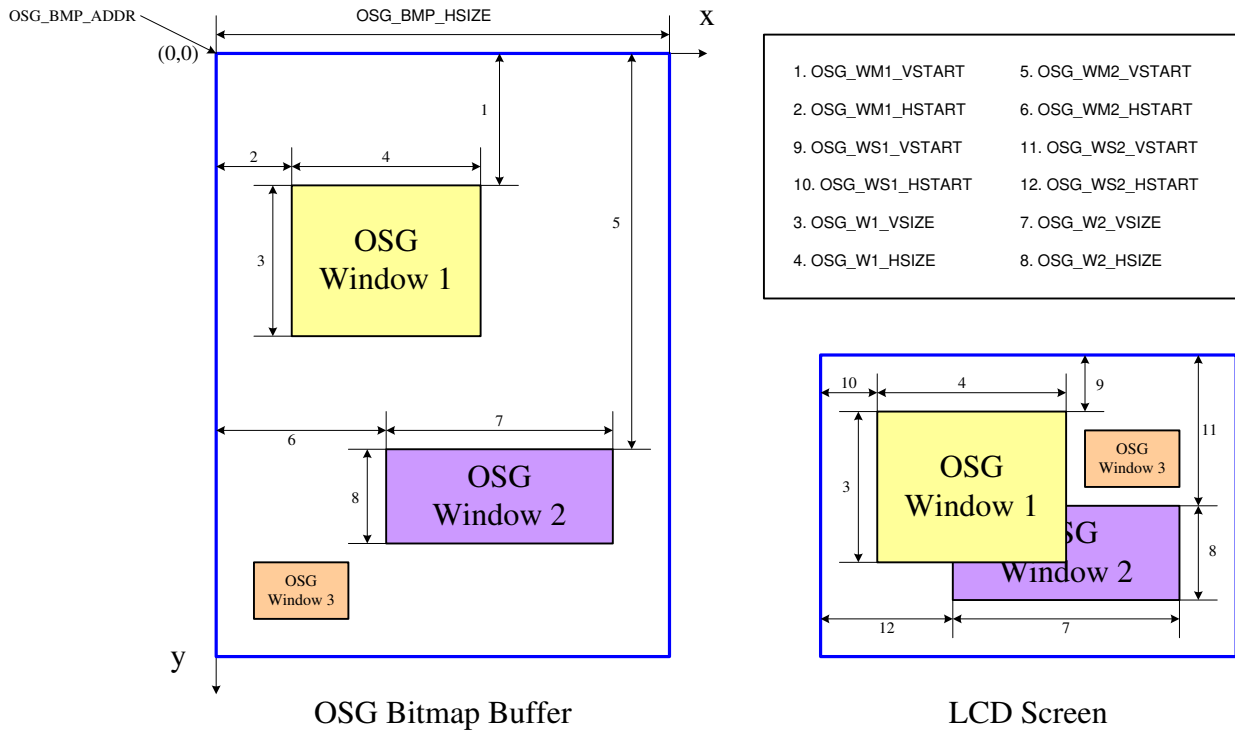

When display, OSG window 3 will overlay lower video, OSG window 2 will overlay OSG window 3, and OSG window 1 will overlay OSG window 2. The sequence of display is:

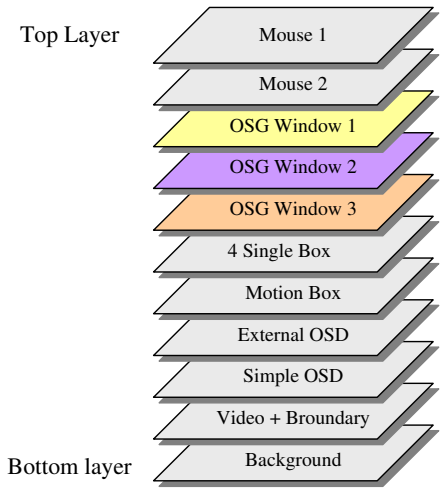

Display modes of three windows are separate for transparent, alpha blending, blinking.

EIGHT SUB-WINDOWS

In each OSG window, there are 8 sub-windows which can select from 8 different SDRAM contents. All eight windows can be different size and position, but cannot overlap.

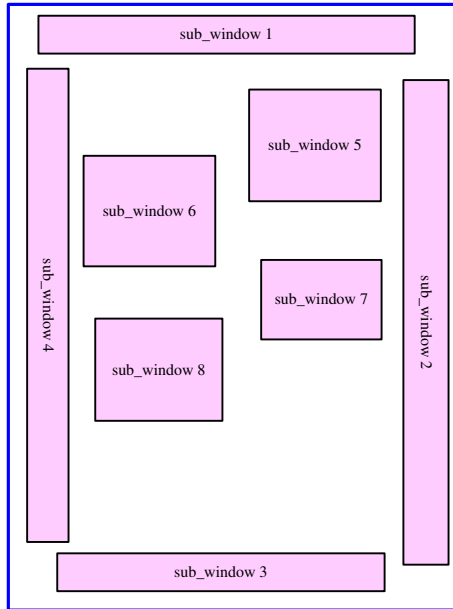

Each window has its own position and size. To set different register, user must set register OSG_W1_SEL for window 1, OSG_W2_SEL or window 2, and OSG_W3_SEL for window 3. Each sub-window can be turn on or off by register OSG_W1_ENn or OSG_W2_ENn or OSG_W3_ENn. Here n is sub-window number. OSG_WM1_VSTARTn, OSG_WM1_HSTARTn, OSG_W1_VSIZEEn, OSG_W1_HSIZEEn, OSG_WS1_VSTARTn and OSG_WS1_HSTARTn share same address.

TRANSPARENT

TW2880 has a fixed transparent color: 0xFFFF. To enable transparent, set bit OSG_TRANS_EN to high. The pixels with color 0xFFFF will not be display on screen. The lower layer image will be displayed. If OSG_TRANS_EN is set to low, all the pixels not in OSG window will display white.

ALPHA BLENDING

Register 0x105[3:2], 0x106[3:2] and 0x163[3:2] are used blending mode control. It controls the alpha blending function of a OSG window. Mode "00" will disable blending. The other three modes enable alpha blending. When mode "01" enabled, pixels with color OSG_ALPHA_COLOR will be mixed with lower layer image, and the other pixels will overwrite lower layer image. When mode "10" enabled, pixels with color OSG_ALPHA_COLOR will overwrite lower layer image, and the other pixels will mixed with lower layer image. When mode "11" is set, all the pixels will mixed with lower layer image. The blending function will be: $\text{Video_data} * \text{alpha} + \text{osg_data} * (1 - \text{alpha})$. There are four big register to program alpha. Each window has two blending colors.

BLINKING

When 0x105 bit [5:4] is other than 0x0, the pixel blinking feature is on. This feature allows the pixel to switch back and forth between a foreground color and a background color. Both colors can be programmed. If bit[5:4] equals 0x1, the pixels with color OSG_BLINK_COLOR will blink. If bit[5:4] equals 0x2, the pixels with colors not equals to OSG_BLINK_COLOR will blink. If bit[5:4] equals 0x3, all pixels will blink. The blink speed is determined by programming the OSG_BLINK_FRAME's value.

RGB FORMAT

TW2880 Support for 16 bit RGB Format.

Mode	15	14	13	12	11	10	9	8	7	6	5	4	3	2	1	0		
0	G						R					B						
1	B	G						R					B					
2	A	G						R					B					
3	B	A	G						R					B				

In mode 0, blinking and blending can be done by color. In mode 1 to 3, blinking and blending can be done by pixel.

If OSG_FORMAT_RG is set to high, data in 16bit mode is like:

Mode	15	14	13	12	11	10	9	8	7	6	5	4	3	2	1	0		
0	R						G					B						
1	B	R						G					B					
2	A	R						G					B					
3	B	A	R						G					B				

UPSCALE

OSG can display upscaled bitmap image to screen. That means bitmap in SDRAM can be a small image, and display image can be upscaled image. Three windows can have different upscale ratios. Upscale ratio is determined by original image size to target image size. Original image size is determined by register [0x1C0] to [0x1CB]. Target image size is determined by LCD screen size. Upscale function can be turned on or off by register [0x105], [0x106] or [0x163] bit 6. OSG_WM_HSTART, OSG_WM_VSTART, OSG_WS_HSTART, OSG_WS_VSTART, OSG_W_HSIZE and OSG_W_VSIZE are setting for original size, not for target size.

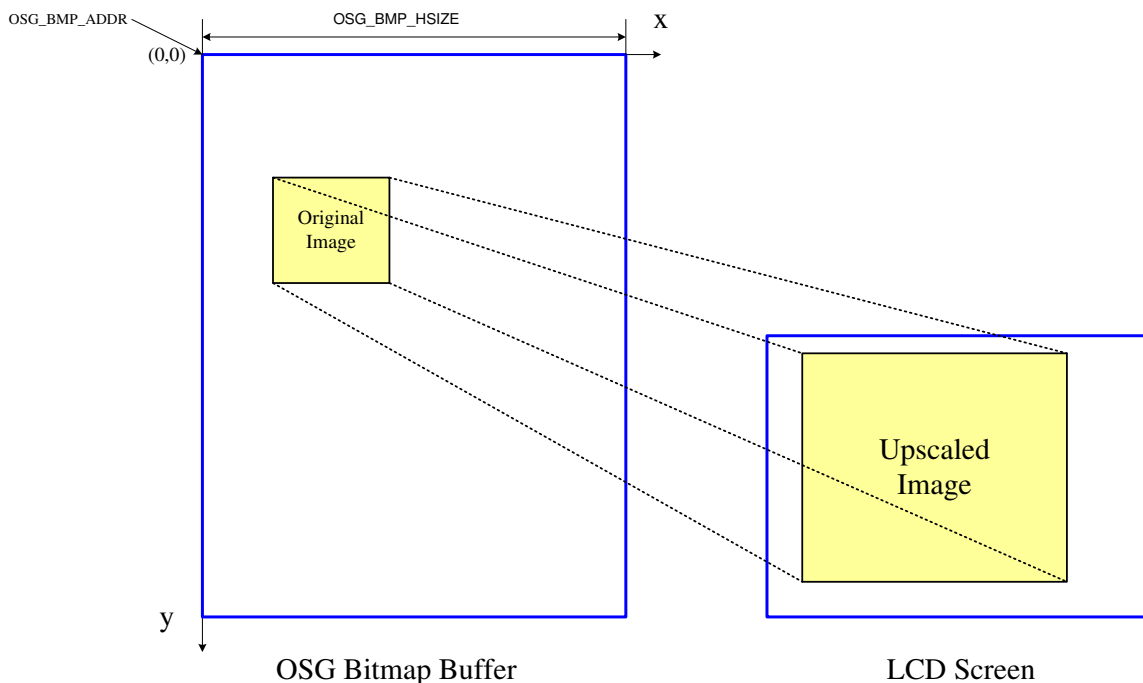

Upscale function is used in bandwidth limitation case. User can use small size bitmap but display it in bigger LCD monitor. For example, original bitmap is 640x480, and LCD monitor is 1920x1080. Then OSG_VSIZE_DN should be 479, and OSG_HSIZE_DN should be 639.

HOST WRITE BUFFER THRESHOLD SETTING

To make the transfer of OSG or menu data to the TW2880 become more efficient, there is a 1K Byte FIFO and some FIFO level control mechanism built in which can be used when the host try to write large amount of OSG data to TW2880.

In transferring OSG data to the off-screen memory, it usually involves consecutive writes the port 0x13A. Although there is a FIFO in the write path, user will still be worried about the operation because once the FIFO becomes full, the subsequent OSG writes will be lost and cannot recover. For this reason user needs to monitor OSG_WR_WAIT ([0x101] bit 1) closely because it represent the buffer state and is controlled by register OSG_TH1 and OSG_TH2. Following is a detailed explanation about the two registers.

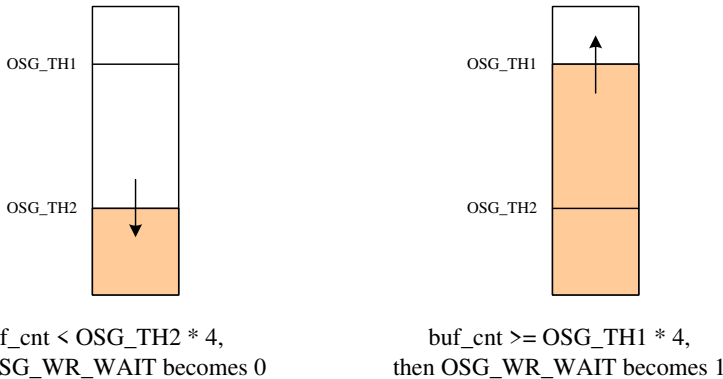

In the above picture, the two rectangles represent the FIFO data level. buf_cnt means data amount in the FIFO. The diagram shows the two criteria's of how the OSG_WR_WAIT change states. So If OSG_WR_WAIT is 0, you can write (1024- OSG_TH1*4) byte to the buffer without polling OSG_WR_WAIT state and the operation will still be right. This is very helpful to cut down the overall CPU overhead in the transfer process.

You must set OSG_TH1 >= OSG_TH2. If OSG_TH2*4 <= buf_cnt < OSG_TH1*4, OSG_WR_WAIT can be 0 or 1. If OSG_WR_WAIT is 0, that means buf_cnt < OSG_TH1*4, if OSG_WR_WAIT is 1, that means buf_cnt >= OSG_TH2*4.

If host does not want to make OSG_WR_WAIT toggle too much, you must set big difference between OSG_TH1 and OSG_TH2. If host does not care about OSG_WR_WAIT toggle too much, set OSG_TH1 = OSG_TH2. The P_WAIT_ST signal is the inverse of OSG_WR_WAIT register bit. Host can use this pin as a CPU halt signal in the total host write flow control.

Host can set a smaller OSG_TH1 value and write a lot of data to TW2880 and don't need to check the status. But if set the OSG_TH1 value become too small the host will need to wait a long time before OSG_WR_WAIT becomes 0. This will stop the transfer flow. The optimized setting is OSG_TH1 = OSG_TH2 = 128. If host want to read the status of OSG_WR_WAIT after writing 1 byte or 1 word, the best way to set OSG_TH1 = OSG_TH2 = 240 or some value close to 255. This is because OSG_WR_WAIT will be "0" most of the time. If carefully spacing the write pulse, host doesn't need to wait at all.

There are three examples for OSG_TH1 and OSG_TH2 setting.

NO.	OSG_TH1	OSG_TH2	USED CASE
1	240	16	When wait_st pin is for interrupt, wait_st will not toggle too frequently
2	128	128	Host can write 512 byte data continuously without checking OSG_WR_WAIT register status
3	240	240	Host write one byte or one word data after checking OSG_WR_WAIT register status. Or Host use wait_st pin as CPU halt signal

HOST WRITE DATA SEQUENCE

Inside OSG design, the buffer uses 16-bit width. So the host needs to write even numbered data. The host can write in little endian sequence or big endian sequence. In default, big endian is used.

For example, if data is 0x12345678...., host write data sequence is:

8-bit mode, big endian, 0x12, 0x34, 0x56, 0x78...

8-bit mode, little endian, 0x34, 0x12, 0x78, 0x56...

16-bit mode, big endian, 0x1234, 0x5678...

16-bit mode, little endian, 0x3412, 0x7856...

Registers Table

Address	R/W	Default	Description
0x100	W	0	[0]: OSG_WR_START
0x101	RO	0	[3]: OSG_VACTIVE [2]: OSG_VBLANK_TOGGLE [1]: OSG_WR_WAIT [0]: OSG_WR_BUSY
0x102	R/W	0	[7:6]: OSG_WR_MODE [5]: OSG_RLC_EN [4]: OSG_COLCON_EN [3]: OSG_FORMAT_RG [2:1]: OSG_OVWR_MODE [0]: OSG_PIXEL_BIT
0x103	R/W	0x80	[7:4]: OSG_CNT_BIT [3:2]: OSG_FORMAT [1:0]: OSG_BLINK_FRAME
0x104	R/W	0xCA	OSG_BITBLIT_OP
0x105	R/W	0	[6]: OSG_UPSCL_EN1 [5:4]: OSG_BLINK_MODE1 [3:2]: OSG_BLEND_MODE1 [1]: OSG_TRANS_EN1 [0]: OSG_W1_EN
0x106	R/W	0	[6]: OSG_UPSCL_EN2 [5:4]: OSG_BLINK_MODE2 [3:2]: OSG_BLEND_MODE2 [1]: OSG_TRANS_EN2 [0]: OSG_W2_EN
0x107	R/W	0	[7:4]: OSG_ALPHA2 [3:0]: OSG_ALPHA1
0x108	R/W	0	OSG_ALPHA_COLOR1 [7:0]
0x109	R/W	0	OSG_ALPHA_COLOR1 [15:8]
0x10A	R/W	0	OSG_ALPHA_COLOR2 [7:0]
0x10B	R/W	0	OSG_ALPHA_COLOR2 [15:8]
0x10C	R/W	0	OSG_ALPHA_COLOR3 [7:0]
0x10D	R/W	0	OSG_ALPHA_COLOR3 [15:8]
0x10E	R/W	0	OSG_ALPHA_COLOR4 [7:0]
0x10F	R/W	0	OSG_ALPHA_COLOR4 [15:8]
0x110	R/W	0	OSG_BLINK_COLOR1 [7:0]
0x111	R/W	0	OSG_BLINK_COLOR1 [15:8]
0x112	R/W	0	OSG_BLINK_COLOR2 [7:0]
0x113	R/W	0	OSG_BLINK_COLOR2 [15:8]
0x114	R/W	0	OSG_FILL_COLOR [7:0]
0x115	R/W	0	OSG_FILL_COLOR [15:8]
0x116	R/W	0	OSG_OVWR_COLOR [7:0]
0x117	R/W	0	OSG_OVWR_COLOR [15:8]
0x118	R/W	0	OSG_CON_SRC1 [7:0]
0x119	R/W	0	OSG_CON_SRC1 [15:8]
0x11A	R/W	0	OSG_CON_TAR1 [7:0]
0x11B	R/W	0	OSG_CON_TAR1 [15:8]
0x11C	R/W	0	OSG_CON_SRC2 [7:0]
0x11D	R/W	0	OSG_CON_SRC2 [15:8]
0x11E	R/W	0	OSG_CON_TAR2 [7:0]
0x11F	R/W	0	OSG_CON_TAR2 [15:8]
0x120	R/W	0	OSG_CON_SRC3 [7:0]

Address	R/W	Default	Description
0x121	R/W	0	OSG_CON_SRC3 [15:8]
0x122	R/W	0	OSG_CON_TAR3 [7:0]
0x123	R/W	0	OSG_CON_TAR3 [15:8]
0x124	R/W	0	OSG_CON_SRC4 [7:0]
0x125	R/W	0	OSG_CON_SRC4 [15:8]
0x126	R/W	0	OSG_CON_TAR4 [7:0]
0x127	R/W	0	OSG_CON_TAR4 [15:8]
0x128	R/W	0	OSG_BMP_HSIZE [7:0]
0x129	R/W	0	OSG_BMP_HSIZE [13:8]
0x12A	R/W	0	OSG_B1_VSTART [7:0]
0x12B	R/W	0	OSG_B1_VSTART [12:8]
0x12C	R/W	0	OSG_B1_HSTART [7:0]
0x12D	R/W	0	OSG_B1_HSTART [12:8]
0x12E	R/W	0	OSG_B1_VSIZE [7:0]
0x12F	R/W	0	OSG_B1_VSIZE [13:8]
0x130	R/W	0	OSG_B1_HSIZE [7:0]
0x131	R/W	0	OSG_B1_HSIZE [13:8]
0x132	R/W	0	OSG_B2_VSTART [7:0]
0x133	R/W	0	OSG_B2_VSTART [12:8]
0x134	R/W	0	OSG_B2_HSTART [7:0]
0x135	R/W	0	OSG_B2_HSTART [12:8]
0x136	R/W	0	OSG_B3_VSTART [7:0]
0x137	R/W	0	OSG_B3_VSTART [12:8]
0x138	R/W	0	OSG_B3_HSTART [7:0]
0x139	R/W	0	OSG_B3_HSTART [12:8]
0x13A	R/W	0	OSG_HOST_DATA [7:0] / OSG_HOST_DATA [15:0]
0x13B	R/W	0	OSG_BMP_ADDR [7:0]
0x13C	R/W	0	OSG_BMP_ADDR [15:8]
0x13D	R/W	0	OSG_BMP_ADDR [21:16]
0x144	R/W	0	OSG_WM1_VSTART [7:0]
0x145	R/W	0	OSG_WM1_VSTART [12:8]
0x146	R/W	0	OSG_WM1_HSTART [7:0]
0x147	R/W	0	OSG_WM1_HSTART [12:8]
0x148	R/W	0	OSG_W1_VSIZE [7:0]
0x149	R/W	0	OSG_W1_VSIZE [10:8]
0x14A	R/W	0	OSG_W1_HSIZE [7:0]
0x14B	R/W	0	OSG_W1_HSIZE [10:8]
0x14C	R/W	0	OSG_WS1_VSTART [7:0]
0x14D	R/W	0	OSG_WS1_VSTART [10:8]
0x14E	R/W	0	OSG_WS1_HSTART [7:0]
0x14F	R/W	0	OSG_WS1_HSTART [10:8]
0x150	R/W	0	OSG_WM2_VSTART [7:0]
0x151	R/W	0	OSG_WM2_VSTART [12:8]
0x152	R/W	0	OSG_WM2_HSTART [7:0]
0x153	R/W	0	OSG_WM2_HSTART [12:8]
0x154	R/W	0	OSG_W2_VSIZE [7:0]
0x155	R/W	0	OSG_W2_VSIZE [10:8]
0x156	R/W	0	OSG_W2_HSIZE [7:0]
0x157	R/W	0	OSG_W2_HSIZE [10:8]
0x158	R/W	0	OSG_WS2_VSTART [7:0]
0x159	R/W	0	OSG_WS2_VSTART [10:8]
0x15A	R/W	0	OSG_WS2_HSTART [7:0]

Address	R/W	Default	Description
0x15B	R/W	0	OSG_WS2_HSTART [10:8]
0x15C	RW	0	OSG_OVWR_COLOR2 [7:0]
0x15D	RW	0	OSG_OVWR_COLOR2 [15:8]
0x15E	RW	0	OSG_OVWR_COLOR3 [7:0]
0x15F	RW	0	OSG_OVWR_COLOR3 [15:8]
0x160	RW	0	OSG_OVWR_COLOR4 [7:0]
0x161	RW	0	OSG_OVWR_COLOR4 [15:8]
0x162	RW	0	[4]: OSG_WAIT_PINEN [3:1]: OSG_VBLANK_SEL [0]: OSG_VBLANK_EN
0x163	R/W	0	[6]: OSG_UPSCL_EN3 [5:4]: OSG_BLINK_MODE3 [3:2]: OSG_BLEND_MODE3 [1]: OSG_TRANS_EN3 [0]: OSG_W3_EN
0x164	R/W	0	[3:0]: OSG_ALPHA3
0x165	R/W	0	OSG_ALPHA_COLOR5 [7:0]
0x166	R/W	0	OSG_ALPHA_COLOR5 [15:8]
0x167	R/W	0	OSG_ALPHA_COLOR6 [7:0]
0x168	R/W	0	OSG_ALPHA_COLOR6 [15:8]
0x169	R/W	0	OSG_BLINK_COLOR3 [7:0]
0x16A	R/W	0	OSG_BLINK_COLOR3 [15:8]
0x16B	R/W	0x01	[7]: OSG_W1_EN8 [6]: OSG_W1_EN7 [5]: OSG_W1_EN6 [4]: OSG_W1_EN5 [3]: OSG_W1_EN4 [2]: OSG_W1_EN3 [1]: OSG_W1_EN2 [0]: OSG_W1_EN1
0x16C	R/W	0x01	[7]: OSG_W2_EN8 [6]: OSG_W2_EN7 [5]: OSG_W2_EN6 [4]: OSG_W2_EN5 [3]: OSG_W2_EN4 [2]: OSG_W2_EN3 [1]: OSG_W2_EN2 [0]: OSG_W2_EN1
0x16D	R/W	0x01	[7]: OSG_W3_EN8 [6]: OSG_W3_EN7 [5]: OSG_W3_EN6 [4]: OSG_W3_EN5 [3]: OSG_W3_EN4 [2]: OSG_W3_EN3 [1]: OSG_W3_EN2 [0]: OSG_W3_EN1
0x16E	R/W	0x00	[6:4]: OSG_W2_SEL [2:0]: OSG_W1_SEL
0x16F	R/W	0x00	[2:0]: OSG_W3_SEL
0x170	R/W	0	OSG_WM3_VSTART [7:0]
0x171	R/W	0	OSG_WM3_VSTART [12:8]
0x172	R/W	0	OSG_WM3_HSTART [7:0]
0x173	R/W	0	OSG_WM3_HSTART [12:8]
0x174	R/W	0	OSG_W3_VSIZE [7:0]

Address	R/W	Default	Description
0x175	R/W	0	OSG_W3_VSIZE [10:8]
0x176	R/W	0	OSG_W3_HSIZE [7:0]
0x177	R/W	0	OSG_W3_HSIZE [10:8]
0x178	R/W	0	OSG_WS3_VSTART [7:0]
0x179	R/W	0	OSG_WS3_VSTART [10:8]
0x17A	R/W	0	OSG_WS3_HSTART [7:0]
0x17B	R/W	0	OSG_WS3_HSTART [10:8]
0x17C	R/W	0	OSG_TH1 [7:0]
0x17D	R/W	0	OSG_TH2 [7:0]
0x17E	R/W	0	[2]: OSG_LIT_ENDIAN [1]: OSG_FROM_DMA [0]: OSG_FROM_DMA_OSG
0x17F	R/W	0x01	[0]: OSG_REG_UPDATE
0x1C0	R/W	0	OSG_VSIZE_DN1 [7:0]
0x1C1	R/W	0	OSG_VSIZE_DN1 [10:8]
0x1C2	R/W	0	OSG_HSIZE_DN1 [7:0]
0x1C3	R/W	0	OSG_HSIZE_DN1 [10:8]
0x1C4	R/W	0	OSG_VSIZE_DN2 [7:0]
0x1C5	R/W	0	OSG_VSIZE_DN2 [10:8]
0x1C6	R/W	0	OSG_HSIZE_DN2 [7:0]
0x1C7	R/W	0	OSG_HSIZE_DN2 [10:8]
0x1C8	R/W	0	OSG_VSIZE_DN3 [7:0]
0x1C9	R/W	0	OSG_VSIZE_DN3 [10:8]
0x1CA	R/W	0	OSG_HSIZE_DN3 [7:0]
0x1CB	R/W	0	OSG_HSIZE_DN3 [10:8]
0x1CC	R/W	0	OSG_BMP_HSIZE_2 [7:0]
0x1CD	R/W	0	OSG_BMP_HSIZE_2 [13:8]
0x1CE	R/W	0	OSG_BMP_ADDR_2 [7:0]
0x1CF	R/W	0	OSG_BMP_ADDR_2 [15:8]
0x1D0	R/W	0	OSG_BMP_ADDR_2 [21:16]

Register Descriptions

OSG CONTROL REGISTER – 0X100

Bit	R/W	Default	Description
0	W	0	OSG_WR_START Block fill, transfer, BitBlit bitmap write mode start. The mode depends on bit [3:1] in this register 1: start 0: auto clear

OSG STATUS REGISTER 2 – 0X101

Bit	R/W	Default	Description
3	RO	-	OSG_VACTIVE OSG vertical active timing information. 1= video active
2	RO	-	OSG_VBLANK_TOGGLE OSG display timing information. This signal toggles after vertical blank start. Read value can be 1 or zero.
1	RO	-	OSG_WR_WAIT OSG buffer almost full. If high, internal data buffer is full, host cannot write data to hardware. If low, host can continue to write data to hardware. It's used for host write data to OSG memory. It is determined by OSG_TH1 and OSG_TH2 1: become full 0: become empty
0	RO	-	OSG_WR_BUSY OSG write busy. If high, internal state is busy doing writing, host cannot send next command. If low, host can send next command. 1: busy 0: ready

OSG MODE REGISTER 1 – 0X102

Bit	R/W	Default	Description
7:6	RW	0	OSG_WR_MODE Block fill, transfer and OSG memory write mode 00: bitmap/linear memory write by host, through OSG_HOST_DATA 01: block transfer by hardware 10: block fill by hardware 11: BitBlit
5	RW	0	OSG_RLC_EN OSG memory write run length compression enable 1: enable 0: disable

Bit	R/W	Default	Description
4	RW	0	OSG_COLCON_EN OSG memory writing or block transfer color conversion enable 1: enable 0: disable
3	RW	0	OSG_LNRMAP_EN OSG linear address mapping enable 1: enable 0: disable
2:1	RW	0	OSG_OVWR_MODE OSG memory host writing or block transfer selective overwrite mode 00: selective overwrite, mask from registers 01: 0xFFFF will not be written to SDRAM 10: BitBlit with mask 0 11: no BitBlit function, all pixels written to SDRAM
0	R/W	0	OSG_PIXEL_BIT When writing OSG bitmap buffer, input data width can be 2 or 16. When 2 bit is used, 2 bit will be expanded to 16 bit. In this case, 00 will be expanded to OSG_CON_TAR1, 01 will be expanded to OSG_CON_TAR2, 10 will be expanded to OSG_CON_TAR3, and 11 will be expanded to OSG_CON_TAR4. 1: 2 bit / pixel 0: 16 bit / pixel

OSG MODE REGISTER 2 - 0X103

Bit	R/W	Default	Description
7:4	R/W	8	OSG_CNT_BIT It is used for compressed data count bit number. 0 means 16 bits.
3:2	R/W	0	OSG_FORMAT OSG 16 bit data format 00: RGB 565 format 01: Blinking bit + RGB 555 format 10: Alpha bit + RGB 555 format 11: Blinking and alpha bit + RGB 554 format
1:0	R/W	0	OSG_BLINK_FRAME OSG blinking frequency control 00: blinking on each 32 frames 01: blinking on each 16 frames 10: blinking on each 8 frames 11: blinking on each 4 frames

OSG BITBLT OPERATION REGISTER – 0X104

Bit	R/W	Default	Description
7:0	R/W	0xCA	OSG_BITBLIT_OP User need to fill in OPENGL style 3OP BitBlit opcode

OSG DISPLAY WINDOW 1 CONTROL REGISTER – 0X105

Bit	R/W	Default	Description
6	R/W	0	OSG_UPSCL_EN1 Upscale enable 0: disable 1: enable
5:4	R/W	0	OSG_BLINK_MODE1 Blink enable. Blink frequency is determined by OSG_BLINK_FRAME 00: blink disable 01: blink in pixels with color OSG_BLINK_COLOR 10: blink in pixels with color not equals to OSG_BLINK_COLOR 11: blink in all pixels
3:2	R/W	0	OSG_BLEND_MODE1 00: alpha blending disable 01: alpha blending in pixels with color OSG_ALPHA_COLOR 10: alpha blending in pixels with color not equals to OSG_ALPHA_COLOR 11: alpha blending in all pixels
1	R/W	0	OSG_TRANS_EN1 OSG transparent enable 1: transparent when data is 0xFFFF 0: do not transparent
0	R/W	0	OSG_W1_EN OSG first window enable 1: enable 0: disable

OSG DISPLAY WINDOW 2 CONTROL REGISTER – 0X106

Bit	R/W	Default	Description
6	R/W	0	OSG_UPSCL_EN2 Upscale enable 0: disable 1: enable
5:4	R/W	0	OSG_BLINK_MODE2 Blink enable. Blink frequency is determined by OSG_BLINK_FRAME 00: blink disable 01: blink in pixels with color OSG_BLINK_COLOR 10: blink in pixels with color not equals to OSG_BLINK_COLOR 11: blink in all pixels

Bit	R/W	Default	Description
3:2	R/W	0	OSG_BLEND_MODE2 00: alpha blending disable 01: alpha blending in pixels with color OSG_ALPHA_COLOR 10: alpha blending in pixels with color not equals to OSG_ALPHA_COLOR 11: alpha blending in all pixels
1	R/W	0	OSG_TRANS_EN2 OSG transparent enable 1: transparent when daa is 0xFFFF 0: do not transparent
0	R/W	0	OSG_W2_EN OSG second window enable 1: enable 0: disable

OSG ALPHA BLENDING REGISTER – 0X107

Bit	R/W	Default	Description
7:4	R/W	0	OSG_ALPHA2 Alpha blending alpha number for OSG window 2. The output will be: video_data2 * alpha2 + osg_data2 * (1 - alpha2). Here alpha2 = OSG_ALPHA2 / 16. Maximum is 15.
3:0	R/W	0	OSG_ALPHA1 Alpha blending alpha number for OSG window 1. The output will be: video_data1 * alpha1 + osg_data1 * (1 - alpha1). Here alpha1 = OSG_ALPHA1 / 16. Maximum is 15.

OSG ALPHA BLENDING COLOR LOW BYTE REGISTER – 0X108

Bit	R/W	Default	Description
7:0	R/W	0	OSG_ALPHA_COLOR1 [7:0] Alpha blending color for OSG window 1. RGB565 color

OSG ALPHA BLENDING COLOR HIGH BYTE REGISTER – 0X109

Bit	R/W	Default	Description
7:0	R/W	0	OSG_ALPHA_COLOR1 [15:8] Alpha blending color for OSG window 1. RGB565 color

OSG ALPHA BLENDING COLOR LOW BYTE REGISTER – 0X10A

Bit	R/W	Default	Description
7:0	R/W	0	OSG_ALPHA_COLOR2 [7:0] Alpha blending color for OSG window 1. RGB565 color

OSG ALPHA BLENDING COLOR HIGH BYTE REGISTER – 0X10B

Bit	R/W	Default	Description
7:0	R/W	0	OSG_ALPHA_COLOR2 [15:8] Alpha blending color for OSG window 1. RGB565 color

OSG ALPHA BLENDING COLOR LOW BYTE REGISTER – 0X10C

Bit	R/W	Default	Description
7:0	R/W	0	OSG_ALPHA_COLOR3 [7:0] Alpha blending color for OSG window 2. RGB565 color

OSG ALPHA BLENDING COLOR HIGH BYTE REGISTER – 0X10D

Bit	R/W	Default	Description
7:0	R/W	0	OSG_ALPHA_COLOR3 [15:8] Alpha blending color for OSG window 2. RGB565 color

OSG ALPHA BLENDING COLOR LOW BYTE REGISTER – 0X10E

Bit	R/W	Default	Description
7:0	R/W	0	OSG_ALPHA_COLOR4 [7:0] Alpha blending color for OSG window 2. RGB565 color

OSG ALPHA BLENDING COLOR HIGH BYTE REGISTER – 0X10F

Bit	R/W	Default	Description
7:0	R/W	0	OSG_ALPHA_COLOR4 [15:8] Alpha blending color for OSG window 2. RGB565 color

OSG BLINKING FOREGROUND COLOR LOW BYTE REGISTER – 0X110

Bit	R/W	Default	Description
7:0	R/W	0	OSG_BLINK_COLOR1 [7:0] Blinking foreground color for OSG window 1. RGB565 color

OSG BLINKING FOREGROUND COLOR HIGH BYTE REGISTER – 0X111

Bit	R/W	Default	Description
7:0	R/W	0	OSG_BLINK_COLOR1 [15:8] Blinking foreground color for OSG window 1. RGB565 color

OSG BLINKING FOREGROUND COLOR LOW BYTE REGISTER – 0X112

Bit	R/W	Default	Description
7:0	R/W	0	OSG_BLINK_COLOR2 [7:0] Blinking foreground color for OSG window 2. RGB565 color

OSG BLINKING FOREGROUND COLOR HIGH BYTE REGISTER – 0X113

Bit	R/W	Default	Description
7:0	R/W	0	OSG_BLINK_COLOR2 [15:8] Blinking foreground color for OSG window 2. RGB565 color

OSG FILL COLOR LOW BYTE – 0X114

Bit	R/W	Default	Description
7:0	R/W	0x00	OSG_FILL_COLOR [7:0] The auto filled pixel color in OSG bitmap buffer, RGB565 color

OSG FILL COLOR HIGH BYTE – 0X115

Bit	R/W	Default	Description
7:0	R/W	0x00	OSG_FILL_COLOR [15:8] The auto filled pixel color in OSG bitmap buffer, RGB565 color

OSG OVERWRITE COLOR LOW BYTE – 0X116

Bit	R/W	Default	Description
7:0	R/W	0x00	OSG_OVWR_COLOR [7:0] When OSG writing bitmap or block transfer, the pixels with this color will not be written to the memory.

OSG OVERWRITE COLOR HIGH BYTE – 0X117

Bit	R/W	Default	Description
7:0	R/W	0x00	OSG_OVWR_COLOR [15:8] When OSG writing bitmap or block transfer, the pixels with this color will not be written to the memory.

OSG COLOR CONVERSION SOURCE COLOR 1 LOW BYTE – 0X118

Bit	R/W	Default	Description
7:0	R/W	0x00	OSG_CON_SRC1 [7:0] When OSG writing bitmap or block transfer, the pixels with this color will be converted to color OSG_CON_TAR1

OSG COLOR CONVERSION SOURCE COLOR 1 HIGH BYTE – 0X119

Bit	R/W	Default	Description
7:0	R/W	0x00	OSG_CON_SRC1 [15:8] When OSG writing bitmap or block transfer, the pixels with this color will be converted to color OSG_CON_TAR1

OSG COLOR CONVERSION TARGET COLOR 1 LOW BYTE – 0X11A

Bit	R/W	Default	Description
7:0	R/W	0x00	OSG_CON_TAR1 [7:0] When OSG writing bitmap or block transfer, the pixels with color OSG_CON_SRC1 will be converted to this color

OSG COLOR CONVERSION TARGET COLOR 1 HIGH BYTE – 0X11B

Bit	R/W	Default	Description
7:0	R/W	0x00	OSG_CON_TAR1 [15:8] When OSG writing bitmap or block transfer, the pixels with color OSG_CON_SRC1 will be converted to this color

OSG COLOR CONVERSION SOURCE COLOR 2 LOW BYTE – 0X11C

Bit	R/W	Default	Description
7:0	R/W	0x00	OSG_CON_SRC2 [7:0] When OSG writing bitmap or block transfer, the pixels with this color will be converted to color OSG_CON_TAR2

OSG COLOR CONVERSION SOURCE COLOR 2 HIGH BYTE – 0X11D

Bit	R/W	Default	Description
7:0	R/W	0x00	OSG_CON_SRC2 [15:8] When OSG writing bitmap or block transfer, the pixels with this color will be converted to color OSG_CON_TAR2

OSG COLOR CONVERSION TARGET COLOR 2 LOW BYTE – 0X11E

Bit	R/W	Default	Description
7:0	R/W	0x00	OSG_CON_TAR2 [7:0] When OSG writing bitmap or block transfer, the pixels with color OSG_CON_SRC2 will be converted to this color

OSG COLOR CONVERSION TARGET COLOR 2 HIGH BYTE – 0X11F

Bit	R/W	Default	Description
7:0	R/W	0x00	OSG_CON_TAR2 [15:8] When OSG writing bitmap or block transfer, the pixels with color OSG_CON_SRC2 will be converted to this color

OSG COLOR CONVERSION SOURCE COLOR 3 LOW BYTE – 0X120

Bit	R/W	Default	Description
7:0	R/W	0x00	OSG_CON_SRC3 [7:0] When OSG writing bitmap or block transfer, the pixels with this color will be converted to color OSG_CON_TAR3

OSG COLOR CONVERSION SOURCE COLOR 3 HIGH BYTE – 0X121

Bit	R/W	Default	Description
7:0	R/W	0x00	OSG_CON_SRC3 [15:8] When OSG writing bitmap or block transfer, the pixels with this color will be converted to color OSG_CON_TAR3

OSG COLOR CONVERSION TARGET COLOR 3 LOW BYTE – 0X122

Bit	R/W	Default	Description
7:0	R/W	0x00	OSG_CON_TAR3 [7:0] When OSG writing bitmap or block transfer, the pixels with color OSG_CON_SRC3 will be converted to this color

OSG COLOR CONVERSION TARGET COLOR 3 HIGH BYTE – 0X123

Bit	R/W	Default	Description
7:0	R/W	0x00	OSG_CON_TAR3 [15:8] When OSG writing bitmap or block transfer, the pixels with color OSG_CON_SRC3 will be converted to this color

OSG COLOR CONVERSION SOURCE COLOR 4 LOW BYTE – 0X124

Bit	R/W	Default	Description
7:0	R/W	0x00	OSG_CON_SRC4 [7:0] When OSG writing bitmap or block transfer, the pixels with this color will be converted to color OSG_CON_TAR4

OSG COLOR CONVERSION SOURCE COLOR 4 HIGH BYTE – 0X125

Bit	R/W	Default	Description
7:0	R/W	0x00	OSG_CON_SRC4 [15:8] When OSG writing bitmap or block transfer, the pixels with this color will be converted to color OSG_CON_TAR4

OSG COLOR CONVERSION TARGET COLOR 4 LOW BYTE – 0X126

Bit	R/W	Default	Description
7:0	R/W	0x00	OSG_CON_TAR4 [7:0] When OSG writing bitmap or block transfer, the pixels with color OSG_CON_SRC4 will be converted to this color

OSG COLOR CONVERSION TARGET COLOR 4 HIGH BYTE – 0X127

Bit	R/W	Default	Description
7:0	R/W	0x00	OSG_CON_TAR4 [15:8] When OSG writing bitmap or block transfer, the pixels with color OSG_CON_SRC4 will be converted to this color

OSG BITMAP BUFFER HORIZONTAL SIZE LOW BYTE – 0X128

Bit	R/W	Default	Description
7:0	R/W	0x00	OSG_BMP_HSIZE [7:0] OSG bitmap buffer total horizontal size for display. The maximum is 8192. Unit is 2 bytes / 1 pixel. The last 7 bit must be 0. OSG_BMP_HSIZE must be times of 128.

OSG BITMAP BUFFER HORIZONTAL SIZE HIGH BYTE – 0X129

Bit	R/W	Default	Description
5:0	R/W	0x00	OSG_BMP_HSIZE [13:8] OSG bitmap buffer total horizontal size for display. The maximum is 8192. Unit is 2 bytes / 1 pixel. The last 7 bit must be 0. OSG_BMP_HSIZE must be times of 128.

OSG BITMAP BUFFER SOURCE WINDOW 1 VERTICAL START LOW BYTE – 0X12A

Bit	R/W	Default	Description
7:0	R/W	0x00	OSG_B1_VSTART [7:0] OSG block transfer memory source 1 vertical start location. Unit is 1 pixel / 2 bytes. The maximum is 8191.

OSG BITMAP BUFFER SOURCE WINDOW 1 VERTICAL START HIGH BYTE – 0X12B

Bit	R/W	Default	Description
4:0	R/W	0x00	OSG_B1_VSTART [12:8] OSG block transfer memory source 1 vertical start location. Unit is 1 pixel / 2 bytes. The maximum is 8191.

OSG BITMAP BUFFER SOURCE WINDOW 1 HORIZONTAL START LOW BYTE – 0X12C

Bit	R/W	Default	Description
7:0	R/W	0x00	OSG_B1_HSTART [7:0] OSG block transfer memory source 1 Horizontal start location. Unit is 1 pixel / 2 bytes. The maximum is 8191.

OSG BITMAP BUFFER SOURCE WINDOW 1 HORIZONTAL START HIGH BYTE – 0X12D

Bit	R/W	Default	Description
4:0	R/W	0x00	OSG_B1_HSTART [12:8] OSG block transfer memory source 1 Horizontal start location. Unit is 1 pixel / 2 bytes. The maximum is 8191.

OSG BITMAP BUFFER SOURCE WINDOW 1 VERTICAL SIZE LOW BYTE – 0X12E

Bit	R/W	Default	Description
7:0	R/W	0x00	OSG_B1_VSIZE [7:0] OSG block transfer memory source 1 vertical size. Unit is 1 pixel / 2 bytes. The maximum is 8192. This is also used for OSG bitmap write target size, block transfer / fill target size.

OSG BITMAP BUFFER SOURCE WINDOW 1 VERTICAL SIZE HIGH BYTE – 0X12F

Bit	R/W	Default	Description
5:0	R/W	0x00	OSG_B1_VSIZE [13:8] OSG block transfer memory source 1 vertical size. Unit is 1 pixel / 2 bytes. The maximum is 8192. This is also used for OSG bitmap write target size, block transfer / fill target size.

OSG BITMAP BUFFER SOURCE WINDOW 1 HORIZONTAL SIZE LOW BYTE – 0X130

Bit	R/W	Default	Description
7:0	R/W	0x00	OSG_B1_HSIZE [7:0] OSG block transfer memory source 1 horizontal size. Unit is 1 pixel / 2 bytes. The maximum is 8192. This is also used for OSG bitmap write target size, block transfer / fill target size.

OSG BITMAP BUFFER SOURCE WINDOW 1 HORIZONTAL SIZE HIGH BYTE – 0X131

Bit	R/W	Default	Description
5:0	R/W	0x00	OSG_B1_HSIZE [13:8] OSG block transfer memory source 1 horizontal size. Unit is 1 pixel / 2 bytes. The maximum is 8192. This is also used for OSG bitmap write target size, block transfer / fill target size.

OSG BITMAP BUFFER TARGET WINDOW VERTICAL START LOW BYTE – 0X132

Bit	R/W	Default	Description
7:0	R/W	0x00	OSG_B2_VSTART [7:0] OSG bitmap write / block transfer / fill memory target vertical start location. Unit is 1 pixel / 2 bytes. The maximum is 4095.

OSG BITMAP BUFFER TARGET WINDOW VERTICAL START HIGH BYTE – 0X133

Bit	R/W	Default	Description
4:0	R/W	0x00	OSG_B2_VSTART [12:8] OSG bitmap write / block transfer / fill memory target vertical start location. Unit is 1 pixel / 2 bytes. The maximum is 8191.

OSG BITMAP BUFFER TARGET WINDOW HORIZONTAL START LOW BYTE – 0X134

Bit	R/W	Default	Description
7:0	R/W	0x00	OSG_B2_HSTART [7:0] OSG bitmap write / block transfer / fill memory target horizontal start location. Unit is 1 pixel / 2 bytes. The maximum is 8191.

OSG BITMAP BUFFER TARGET WINDOW HORIZONTAL START HIGH BYTE – 0X135

Bit	R/W	Default	Description
4:0	R/W	0x00	OSG_B2_HSTART [12:8] OSG block transfer memory source Horizontal start location. Unit is 1 pixel / 2 bytes. The maximum is 8191.

OSG BITMAP BUFFER SOURCE WINDOW 2 VERTICAL START LOW BYTE – 0X136

Bit	R/W	Default	Description
7:0	R/W	0x00	OSG_B3_VSTART [7:0] OSG block transfer memory source 2 vertical start location. Unit is 1 pixel / 2 bytes. The maximum is 8191. It's used for BitBlit.

OSG BITMAP BUFFER SOURCE WINDOW 2 VERTICAL START HIGH BYTE – 0X137

Bit	R/W	Default	Description
4:0	R/W	0x00	OSG_B3_VSTART [12:8] OSG block transfer memory source 2 vertical start location. Unit is 1 pixel / 2 bytes. The maximum is 8191. It's used for BitBlit.

OSG BITMAP BUFFER SOURCE WINDOW 2 HORIZONTAL START LOW BYTE – 0X138

Bit	R/W	Default	Description
7:0	R/W	0x00	OSG_B3_HSTART [7:0] OSG block transfer memory source 2 Horizontal start location. Unit is 1 pixel / 2 bytes. The maximum is 8191. It's used for BitBlit.

BITMAP BUFFER SOURCE WINDOW 2 HORIZONTAL START HIGH BYTE – 0X139

Bit	R/W	Default	Description
4:0	R/W	0x00	OSG_B3_HSTART [12:8] OSG block transfer memory source 2 Horizontal start location. Unit is 1 pixel / 2 bytes. The maximum is 8191. It's used for BitBit.

OSG HOST WRITE DATA PORT – 0X13A

Bit	R/W	Default	Description
15:8	R/W	0x00	OSG_HOST_DATA [15:8] High byte of the write date port. To use this portion of write port user needs to connect the high byte of the I/O pins and use EN16B signal to let host interface know a valid 16 bit transfer is needed. A 16 bit write will not write into 0x13B.
7:0	R/W	0x00	OSG_HOST_DATA [7:0] The data register for OSG bitmap / linear buffer write. Once the write command is started, CPU keeps writing to this register for the byte count consistent with the setting.

OSG BITMAP BUFFER START ADDRESS LOW BYTE – 0X13B

Bit	R/W	Default	Description
7:0	R/W	0x00	OSG_BMP_ADDR [7:0] The bitmap buffer start address for display. Unit is 8 bytes / 4 pixels. Total is 21 bits. Start bank is fixed to 0.

OSG BITMAP BUFFER START ADDRESS MIDDLE BYTE – 0X13C

Bit	R/W	Default	Description
7:0	R/W	0x00	OSG_BMP_ADDR [15:8] The bitmap buffer start address for display. Unit is 8 bytes / 4 pixels. Total is 21 bits. Start bank is fixed to 0.

OSG BITMAP BUFFER START ADDRESS HIGH BYTE – 0X13D

Bit	R/W	Default	Description
7:0	R/W	0x00	OSG_BMP_ADDR [23:16] The bitmap buffer start address for display. Unit is 8 bytes / 4 pixels. Total is 24 bits. Start bank is fixed to 0 when bit [23] = 0. Start bank = bit [22:21] when bit [23] = 1

OSG FORMAT CONTROL – 0X17E

Bit	R/W	Default	Description
4	R/W	0	OSG_YcrCb2RGB 0: No conversion 1: Convert Y Cr Cb format to RGB
2	R/W	0	OSG_LIT_ENDIAN 0: big endian 1: little endian
1	R/W	0	OSG_FROM_DMA 0: Host DMA module write data directly to SDRAM 1: Host DMA module does not write data to SDRAM
0	R/W	0	OSG_FROM_DMA_OSG 0: OSG data is from CPU 1: OSG data is from host DMA module

OSG BITMAP BUFFER START ADDRESS HIGH BYTE – 0X13D

Bit	R/W	Default	Description
4:0	R/W	0x00	OSG_BMP_ADDR [21:16] The bitmap buffer start address for display. Unit is 8 bytes / 4 pixels. Total is 22 bits. Start bank is fixed to 0.

OSG WINDOW 1 VERTICAL START IN BITMAP BUFFER LOW BYTE – 0X144

Bit	R/W	Default	Description
7:0	R/W	0x00	OSG_WM1_VSTART [7:0] OSG first window vertical start in bitmap memory. Unit is 1 pixel / 2 bytes. The maximum is 4095.

OSG WINDOW 1 VERTICAL START IN BITMAP BUFFER HIGH BYTE – 0X145

Bit	R/W	Default	Description
4:0	R/W	0x00	OSG_WM1_VSTART [12:8] OSG first window vertical start in bitmap memory. Unit is 1 pixel / 2 bytes. The maximum is 8191.

OSG WINDOW 1 HORIZONTAL START IN BITMAP BUFFER LOW BYTE – 0X146

Bit	R/W	Default	Description
7:0	R/W	0x00	OSG_WM1_HSTART [7:0] OSG first window horizontal start in bitmap memory. Unit is 1 pixel / 2 bytes. The maximum is 8191.

OSG WINDOW 1 HORIZONTAL START IN BITMAP BUFFER HIGH BYTE – 0X147

Bit	R/W	Default	Description
4:0	R/W	0x00	OSG_WM1_HSTART [12:8] OSG first window horizontal start in bitmap memory. Unit is 1 pixel / 2 bytes. The maximum is 8191.

OSG WINDOW 1 VERTICAL SIZE LOW BYTE – 0X148

Bit	R/W	Default	Description
7:0	R/W	0x00	OSG_W1_VSIZE [7:0] OSG first window vertical size. Unit is 1 pixel / 2 bytes. The maximum is 2047.

OSG WINDOW 1 VERTICAL SIZE HIGH BYTE – 0X149

Bit	R/W	Default	Description
2:0	R/W	0x00	OSG_W1_VSIZE [10:8] OSG first window vertical size. Unit is 1 pixel / 2 bytes. The maximum is 2047.

OSG WINDOW 1 HORIZONTAL SIZE LOW BYTE – 0X14A

Bit	R/W	Default	Description
7:0	R/W	0x00	OSG_W1_HSIZE [7:0] OSG first window horizontal size. Unit is 1 pixel / 2 bytes. The maximum is 2047.

OSG WINDOW 1 HORIZONTAL SIZE HIGH BYTE – 0X14B

Bit	R/W	Default	Description
2:0	R/W	0x00	OSG_W1_HSIZE [10:8] OSG first window horizontal size. Unit is 1 pixel / 2 bytes. The maximum is 2047.

OSG WINDOW 1 VERTICAL START ON SCREEN LOW BYTE – 0X14C

Bit	R/W	Default	Description
7:0	R/W	0x00	OSG_WS1_VSTART [7:0] OSG first window vertical start on screen. Unit is 1 pixel / 2 bytes. The maximum is 2047.

OSG WINDOW 1 VERTICAL START ON SCREEN HIGH BYTE – 0X14D

Bit	R/W	Default	Description
2:0	R/W	0x00	OSG_WS1_VSTART [10:8] OSG first window vertical start on screen. Unit is 1 pixel / 2 bytes. The maximum is 2047.

OSG WINDOW 1 HORIZONTAL START ON SCREEN LOW BYTE – 0X14E

Bit	R/W	Default	Description
7:0	R/W	0x00	OSG_WS1_HSTART [7:0] OSG first window horizontal start on screen. Unit is 1 pixel / 2 bytes. The maximum is 2047.

OSG WINDOW 1 HORIZONTAL START ON SCREEN HIGH BYTE – 0X14F

Bit	R/W	Default	Description
2:0	R/W	0x00	OSG_WS1_HSTART [10:8] OSG first window horizontal start on screen. Unit is 1 pixel / 2 bytes. The maximum is 2047.

OSG WINDOW 2 VERTICAL START IN BITMAP BUFFER LOW BYTE – 0X150

Bit	R/W	Default	Description
7:0	R/W	0x00	OSG_WM2_VSTART [7:0] OSG second window vertical start in bitmap memory. Unit is 1 pixel / 2 bytes. The maximum is 8191.

OSG WINDOW 2 VERTICAL START IN BITMAP BUFFER HIGH BYTE – 0X151

Bit	R/W	Default	Description
4:0	R/W	0x00	OSG_WM2_VSTART [12:8] OSG second window vertical start in bitmap memory. Unit is 1 pixel / 2 bytes. The maximum is 8191.

OSG WINDOW 2 HORIZONTAL START IN BITMAP BUFFER LOW BYTE – 0X152

Bit	R/W	Default	Description
7:0	R/W	0x00	OSG_WM2_HSTART [7:0] OSG second window horizontal start in bitmap memory. Unit is 1 pixel / 2 bytes. The maximum is 8191.

OSG WINDOW 2 HORIZONTAL START IN BITMAP BUFFER HIGH BYTE – 0X153

Bit	R/W	Default	Description
4:0	R/W	0x00	OSG_WM2_HSTART [12:8] OSG second window horizontal start in bitmap memory. Unit is 1 pixel / 2 bytes. The maximum is 8191.

OSG WINDOW 2 VERTICAL SIZE LOW BYTE – 0X154

Bit	R/W	Default	Description
7:0	R/W	0x00	OSG_W2_VSIZE [7:0] OSG second window vertical size. Unit is 1 pixel / 2 bytes. The maximum is 2047.

OSG WINDOW 2 VERTICAL SIZE HIGH BYTE – 0X155

Bit	R/W	Default	Description
2:0	R/W	0x00	OSG_W2_VSIZE [10:8] OSG second window vertical size. Unit is 1 pixel / 2 bytes. The maximum is 2047.

OSG WINDOW 2 HORIZONTAL SIZE LOW BYTE – 0X156

Bit	R/W	Default	Description
7:0	R/W	0x00	OSG_W2_HSIZE [7:0] OSG second window horizontal size. Unit is 1 pixel / 2 bytes. The maximum is 2047.

OSG WINDOW 2 HORIZONTAL SIZE HIGH BYTE – 0X157

Bit	R/W	Default	Description
2:0	R/W	0x00	OSG_W2_HSIZE [10:8] OSG second window horizontal size. Unit is 1 pixel / 2 bytes. The maximum is 2047.

OSG WINDOW 2 VERTICAL START ON SCREEN LOW BYTE – 0X158

Bit	R/W	Default	Description
7:0	R/W	0x00	OSG_WS2_VSTART [7:0] OSG second window vertical start on screen. Unit is 1 pixel / 2 bytes. The maximum is 2047.

OSG WINDOW 2 VERTICAL START ON SCREEN HIGH BYTE – 0X159

Bit	R/W	Default	Description
2:0	R/W	0x00	OSG_WS2_VSTART [10:8] OSG second window vertical start on screen. Unit is 1 pixel / 2 bytes. The maximum is 2047.

OSG WINDOW 2 HORIZONTAL START ON SCREEN LOW BYTE – 0X15A

Bit	R/W	Default	Description
7:0	R/W	0x00	OSG_WS2_HSTART [7:0] OSG second window horizontal start on screen. Unit is 1 pixel / 2 bytes. The maximum is 2047.

OSG WINDOW 2 HORIZONTAL START ON SCREEN HIGH BYTE – 0X15B

Bit	R/W	Default	Description
2:0	R/W	0x00	OSG_WS2_HSTART [10:8] OSG second window horizontal start on screen. Unit is 1 pixel / 2 bytes. The maximum is 2047.

OSG OVERWRITE COLOR2 LOW BYTE – 0X15C

Bit	R/W	Default	Description
7:0	R/W	0x00	OSG_OVWR_COLOR2 [7:0] When OSG writing bitmap or block transfer, the pixels with this color will not be written to the memory.

OSG OVERWRITE COLOR2 HIGH BYTE – 0X15D

Bit	R/W	Default	Description
7:0	R/W	0x00	OSG_OVWR_COLOR2 [15:8] When OSG writing bitmap or block transfer, the pixels with this color will not be written to the memory.

OSG OVERWRITE COLOR3 LOW BYTE – 0X15E

Bit	R/W	Default	Description
7:0	R/W	0x00	OSG_OVWR_COLOR3 [7:0] When OSG writing bitmap or block transfer, the pixels with this color will not be written to the memory.

OSG OVERWRITE COLOR3 HIGH BYTE – 0X15F

Bit	R/W	Default	Description
7:0	R/W	0x00	OSG_OVWR_COLOR3 [15:8] When OSG writing bitmap or block transfer, the pixels with this color will not be written to the memory.

OSG OVERWRITE COLOR4 LOW BYTE – 0X160

Bit	R/W	Default	Description
7:0	R/W	0x00	OSG_OVWR_COLOR4 [7:0] When OSG writing bitmap or block transfer, the pixels with this color will not be written to the memory.

OSG OVERWRITE COLOR4 HIGH BYTE – 0X161

Bit	R/W	Default	Description
7:0	R/W	0x00	OSG_OVWR_COLOR4 [15:8] When OSG writing bitmap or block transfer, the pixels with this color will not be written to the memory.

OSG VERTICAL BLANK REGISTER – 0X162

Bit	R/W	Default	Description
7:5	–	–	Reserved
4	R/W	0	OSG_WAIT_PINEN Wait pin enable. If this bit is set to high, wait pin will be low when OSG_WR_WAIT is high. If this bit is set to low, wait pin is always high (open drain).
3:1	R/W	0	OSG_VBLANK_SEL [1:0] 000: osg1_vblank 001: osg1_vblank_window 010: osg2_vblank 011: osg2_vblank_window 100: osg3_vblank 101: osg3_vblank_window Others: Reserved
0	R/W	0	OSG_VBLANK_EN When this bit set to high, OSG write start begins from vertical blank start. Vertical blank is selected by OSG_VBLANK_SEL register.

OSG DISPLAY WINDOW 3 CONTROL REGISTER – 0X163

Bit	R/W	Default	Description
6	R/W	0	OSG_UPSCL_EN3: Upscale enable 0: disable 1: enable
5:4	R/W	0	OSG_BLINK_MODE3 Blink enable. Blink frequency is determined by OSG_BLINK_FRAME 00: blink disable 01: blink in pixels with color OSG_BLINK_COLOR 10: blink in pixels with color not equals to OSG_BLINK_COLOR 11: blink in all pixels

Bit	R/W	Default	Description
3:2	R/W	0	OSG_BLEND_MODE3 00: alpha blending disable 01: alpha blending in pixels with color OSG_ALPHA_COLOR 10: alpha blending in pixels with color not equals to OSG_ALPHA_COLOR 11: alpha blending in all pixels
1	R/W	0	OSG_TRANS_EN3 OSG transparent enable 1: transparent when daa is 0xFFFF 0: do not transparent
0	R/W	0	OSG_W3_EN OSG third window enable 1: enable 0: disable

OSG ALPHA BLENDING REGISTER – 0X164

Bit	R/W	Default	Description
7:4	-	-	Reserved
3:0	R/W	0	OSG_ALPHA3 Alpha blending alpha number for OSG window 3. The output will be: video_data3 * alpha3 + osg_data3 * (1 - alpha3). Here alpha3 = OSG_ALPHA3 / 16. Maximum is 15.

OSG ALPHA BLENDING COLOR LOW BYTE REGISTER – 0X165

Bit	R/W	Default	Description
7:0	R/W	0	OSG_ALPHA_COLOR5 [7:0] Alpha blending color for OSG window 3. 16 bit = RGB565

OSG ALPHA BLENDING COLOR HIGH BYTE REGISTER – 0X166

Bit	R/W	Default	Description
7:0	R/W	0	OSG_ALPHA_COLOR5 [15:8] Alpha blending color for OSG window 3. 16 bit = RGB565

OSG ALPHA BLENDING COLOR LOW BYTE REGISTER – 0X167

Bit	R/W	Default	Description
7:0	R/W	0	OSG_ALPHA_COLOR6 [7:0] Alpha blending color for OSG window 3. 16 bit = RGB565

OSG ALPHA BLENDING COLOR HIGH BYTE REGISTER – 0X168

Bit	R/W	Default	Description
7:0	R/W	0	OSG_ALPHA_COLOR6 [15:8] Alpha blending color for OSG window 3. 16 bit = RGB565

OSG BLINKING FOREGROUND COLOR LOW BYTE REGISTER – 0X169

Bit	R/W	Default	Description
7:0	R/W	0	OSG_BLINK_COLOR3 [7:0] Blinking foreground color for OSG window 3. 16 bit = RGB565

OSG BLINKING FOREGROUND COLOR HIGH BYTE REGISTER – 0X16A

Bit	R/W	Default	Description
7:0	R/W	0	OSG_BLINK_COLOR3 [15:8] Blinking foreground color for OSG window 3. 16 bit = RGB565

OSG DISPLAY WINDOW 1 ENABLE REGISTER – 0X16B

Bit	R/W	Default	Description
7	R/W	0	OSG_W1_EN8
6	R/W	0	OSG_W1_EN7
5	R/W	0	OSG_W1_EN6
4	R/W	0	OSG_W1_EN5
3	R/W	0	OSG_W1_EN4
2	R/W	0	OSG_W1_EN3
1	R/W	0	OSG_W1_EN2
0	R/W	1	OSG_W1_EN1 Sub-window enable bits for window 1, 1= enable

OSG DISPLAY WINDOW 2 ENABLE REGISTER – 0X16C

Bit	R/W	Default	Description
7	R/W	0	OSG_W2_EN8
6	R/W	0	OSG_W2_EN7
5	R/W	0	OSG_W2_EN6
4	R/W	0	OSG_W2_EN5
3	R/W	0	OSG_W2_EN4
2	R/W	0	OSG_W2_EN3
1	R/W	0	OSG_W2_EN2
0	R/W	1	OSG_W2_EN1 Sub-window enable bits for window 2, 1= enable

OSG DISPLAY WINDOW 3 ENABLE REGISTER – 0X16D

Bit	R/W	Default	Description
7	R/W	0	OSG_W3_EN8
6	R/W	0	OSG_W3_EN7

Bit	R/W	Default	Description
5	R/W	0	OSG_W3_EN6
4	R/W	0	OSG_W3_EN5
3	R/W	0	OSG_W3_EN4
2	R/W	0	OSG_W3_EN3
1	R/W	0	OSG_W3_EN2
0	R/W	1	OSG_W3_EN1
Sub-window enable bits for window 3, 1= enable			

OSG DISPLAY WINDOW 1 AND 2 SELECT REGISTER – 0X16E

Bit	R/W	Default	Description
7	R	0x00	Reserved
6:4	R/W	0x00	OSG_W2_SEL Sub-windows register selection for window 2
3	R	0x00	Reserved
2:0	R/W	0x00	OSG_W1_SEL Sub-windows register selection for window 1

OSG DISPLAY WINDOW 3 SELECT REGISTER – 0X16F

Bit	R/W	Default	Description
7:3	R	0x00	Reserved
2:0	R/W	0x00	OSG_W3_SEL Sub-windows register selection for window 3

OSG WINDOW 3 VERTICAL START IN BITMAP BUFFER LOW BYTE – 0X170

Bit	R/W	Default	Description
7:0	R/W	0x00	OSG_WM3_VSTART [7:0] OSG third window vertical start in bitmap memory. Unit is 1 pixel / 2 bytes. The maximum is 8191.

OSG WINDOW 3 VERTICAL START IN BITMAP BUFFER HIGH BYTE – 0X171

Bit	R/W	Default	Description
4:0	R/W	0x00	OSG_WM3_VSTART [12:8] OSG third window vertical start in bitmap memory. Unit is 1 pixel / 2 bytes. The maximum is 8191.

OSG WINDOW 3 HORIZONTAL START IN BITMAP BUFFER LOW BYTE – 0X172

Bit	R/W	Default	Description
7:0	R/W	0x00	OSG_WM3_HSTART [7:0] OSG third window horizontal start in bitmap memory. Unit is 1 pixel / 2 bytes. The maximum is 8191.

OSG WINDOW 3 HORIZONTAL START IN BITMAP BUFFER HIGH BYTE – 0X173

Bit	R/W	Default	Description
4:0	R/W	0x00	OSG_WM3_HSTART [12:8] OSG third window horizontal start in bitmap memory. Unit is 1 pixel / 2 bytes. The maximum is 8191.

OSG WINDOW 3 VERTICAL SIZE LOW BYTE – 0X174

Bit	R/W	Default	Description
7:0	R/W	0x00	OSG_W3_VSIZE [7:0] OSG third window vertical size. Unit is 1 pixel / 2 bytes. The maximum is 2047.

OSG WINDOW 3 VERTICAL SIZE HIGH BYTE – 0X175

Bit	R/W	Default	Description
2:0	R/W	0x00	OSG_W3_VSIZE [10:8] OSG third window vertical size. Unit is 1 pixel / 2 bytes. The maximum is 2047.

OSG WINDOW 3 HORIZONTAL SIZE LOW BYTE – 0X176

Bit	R/W	Default	Description
7:0	R/W	0x00	OSG_W3_HSIZE [7:0] OSG third window horizontal size. Unit is 1 pixel / 2 bytes. The maximum is 2047.

OSG WINDOW 3 HORIZONTAL SIZE HIGH BYTE – 0X177

Bit	R/W	Default	Description
2:0	R/W	0x00	OSG_W3_HSIZE [10:8] OSG third window horizontal size. Unit is 1 pixel / 2 bytes. The maximum is 2047.

OSG WINDOW 3 VERTICAL START ON SCREEN LOW BYTE – 0X178

Bit	R/W	Default	Description
7:0	R/W	0x00	OSG_WS3_VSTART [7:0] OSG third window vertical start on screen. Unit is 1 pixel / 2 bytes. The maximum is 2047.

OSG WINDOW 3 VERTICAL START ON SCREEN HIGH BYTE – 0X179

Bit	R/W	Default	Description
2:0	R/W	0x00	OSG_WS3_VSTART [10:8] OSG third window vertical start on screen. Unit is 1 pixel / 2 bytes. The maximum is 2047.

OSG WINDOW 3 HORIZONTAL START ON SCREEN LOW BYTE – 0X17A

Bit	R/W	Default	Description
7:0	R/W	0x00	OSG_WS3_HSTART [7:0] OSG third window horizontal start on screen. Unit is 1 pixel / 2 bytes. The maximum is 2047.

OSG WINDOW 3 HORIZONTAL START ON SCREEN HIGH BYTE – 0X17B

Bit	R/W	Default	Description
2:0	R/W	0x00	OSG_WS3_HSTART [10:8] OSG third window horizontal start on screen. Unit is 1 pixel / 2 bytes. The maximum is 2047.

OSG THRESHOLD 1 – 0X17C

Bit	R/W	Default	Description
7:0	R/W	0x80	OSG_TH1 [7:0] OSG threshold 1. OSG_WR_WAIT will be high when data amount in the buffer is more than OSG_TH1*4. The buffer size is 1024 bytes. OSG_TH1 >= OSG_TH2

OSG THRESHOLD 2 – 0X17D

Bit	R/W	Default	Description
7:0	R/W	0x80	OSG_TH2 [7:0] OSG threshold 2. OSG_WR_WAIT will be low when data amount in the buffer is less than OSG_TH2*4. The buffer size is 1024 bytes. OSG_TH1 >= OSG_TH2

OSG FORMAT CONTROL – 0X17E

Bit	R/W	Default	Description
2	R/W	0	OSG_LIT_ENDIAN 0: big endian 1: little endian
1	R/W	0	OSG_FROM_DMA 0: Host DMA module write data directly to SDRAM 1: Host DMA module does not write data to SDRAM
0	R/W	0	OSG_FROM_DMA_OSG 0: OSG data is from CPU 1: OSG data is from host DMA module

OSG FORMAT CONTROL – 0X17F

Bit	R/W	Default	Description
0	R/W	1	OSG_REG_UPDATE When host update OSG display related registers such as position and size, host must set this bit to 0 and then change those registers. After changing done, host set this bit to 1.

OSG ORIGINAL VERTICAL SIZE FOR WINDOW 1 LOW BYTE– 0X1C0

Bit	R/W	Default	Description
7:0	R/W	0x00	OSG_VSIZE_DN1 [7:0] OSG original vertical size minus 1. Unit is pixel.

OSG ORIGINAL VERTICAL SIZE FOR WINDOW 1 HIGH BYTE – 0X1C1

Bit	R/W	Default	Description
2:0	R/W	0x00	OSG_VSIZE_DN1 [10:8] OSG original vertical size minus 1. Unit is pixel.

OSG ORIGINAL HORIZONTAL SIZE FOR WINDOW 1 LOW BYTE– 0X1C2

Bit	R/W	Default	Description
7:0	R/W	0x00	OSG_HSIZE_DN1 [7:0] OSG original horizontal size minus 1. OSG_HSIZE_DN1+1 must be times of 4.

OSG ORIGINAL HORIZONTAL SIZE FOR WINDOW 1 HIGH BYTE – 0X1C3

Bit	R/W	Default	Description
2:0	R/W	0x00	OSG_HSIZE_DN1 [10:8] OSG original horizontal size minus 1. OSG_HSIZE_DN1+1 must be times of 4.

Register 0x1C4 to 0x1CB are for window 2 to 3

OSG BITMAP BUFFER HORIZONTAL SIZE LOW BYTE – 0X1CC

Bit	R/W	Default	Description
7:0	R/W	0x00	OSG_BMP_HSIZE_2 [7:0] OSG bitmap buffer total horizontal size for OSG write. The maximum is 8192. Unit is 2 bytes / 1 pixel. The last 7 bit must be 0. OSG_BMP_HSIZE must be times of 128.

OSG BITMAP BUFFER HORIZONTAL SIZE HIGH BYTE – 0X1CD

Bit	R/W	Default	Description
5:0	R/W	0x00	OSG_BMP_HSIZE_2 [13:8] OSG bitmap buffer total horizontal size for OSG write. The maximum is 8192. Unit is 2 bytes / 1 pixel. The last 7 bit must be 0. OSG_BMP_HSIZE must be times of 128.

OSG BITMAP BUFFER START ADDRESS LOW BYTE – 0X1CE

Bit	R/W	Default	Description
7:0	R/W	0x00	OSG_BMP_ADDR_2 [7:0] The bitmap buffer start address for OSG write. Unit is 8 bytes / 4 pixels. Total is 21 bits. Start bank is fixed to 0.

OSG BITMAP BUFFER START ADDRESS MIDDLE BYTE – 0X1CF

Bit	R/W	Default	Description
7:0	R/W	0x00	OSG_BMP_ADDR_2 [15:8] The bitmap buffer start address for OSG write. Unit is 8 bytes / 4 pixels. Total is 21 bits. Start bank is fixed to 0.

OSG BITMAP BUFFER START ADDRESS HIGH BYTE – 0X1D0

Bit	R/W	Default	Description
4:0	R/W	0x00	OSG_BMP_ADDR_2 [21:16] The bitmap buffer start address for OSG write. Unit is 8 bytes / 4 pixels. Total is 22 bits. Start bank is fixed to 0.

OSD for Display Path

Introduction

TW2880 OSD controller for display path is a complementary to OSG. Since OSG need a lot of SDRAM bandwidth, this simple OSD controller does not need SDRAM bandwidth. All font tables are stored in local SRAM. It can display channel information for each channel. Channel information includes 8 characters and 1 picture. All information can be selected from 64 fonts and 4 pictures saved in SRAM. Font width can be selected from 6, 8, 12 or 16. Font height can be selected from 8, 10, 16 or 20. Picture size is fixed to 32x32. OSD can also display time and data with 32 characters, and title with 32 characters.

Features

- Support 16 live channels and 16 playback channels
- 64 fonts table
- 4 pictures table
- 8 characters Channel information with one picture
- 32 characters title
- 32 characters time/date
- 2 bit color for font and picture

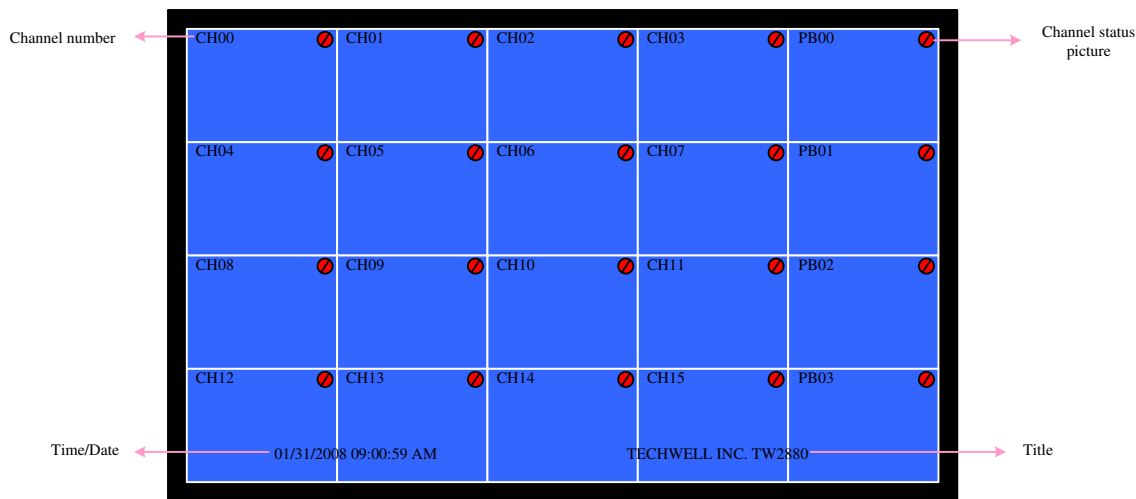

Font and Picture Library

FONT

There are totally 64 fonts which can be saved in SRAM. The font size saved in SRAM is fixed to 8x10. But displayed font size can be changed. Horizontal can display four sizes: 6, 8, 12 or 16. Size 12 or 16 are doubled from size 6 or 8. If 6 or 12 are selected, fonts saved in SRAM must have small size. But additional two pixels must be saved in SRAM. Vertical can display four sizes: 8, 10, 16 or 20. Size 16 or 20 are doubled from size 8 or 10. If 8 or 16 are selected, fonts saved in SRAM must have small size. But additional two lines must be saved in SRAM. The following picture shows SRAM data. For 8x10 font, all SRAM data are valid. For 6x8 font, only 6x8 area are valid. Black area is for dummy data.

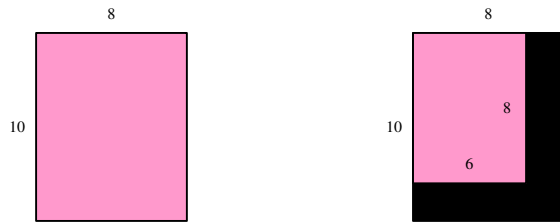

There are 2 bits for each pixel color. 00 means transparent, color 01, 10 and 11 can be set by registers: OSD_FONT_R1 (G1, B1), OSD_FONT_R2 (G2, B2) and OSD_FONT_R3 (G3, B3).

Data saved in SRAM is shown below. There are totally $64 \times 8 \times 10 \times 2 = 640 \times 16$ bits in SRAM. Data are saved font by font. For each font, data is saved line by line. Pixel data in each line is in big endian.

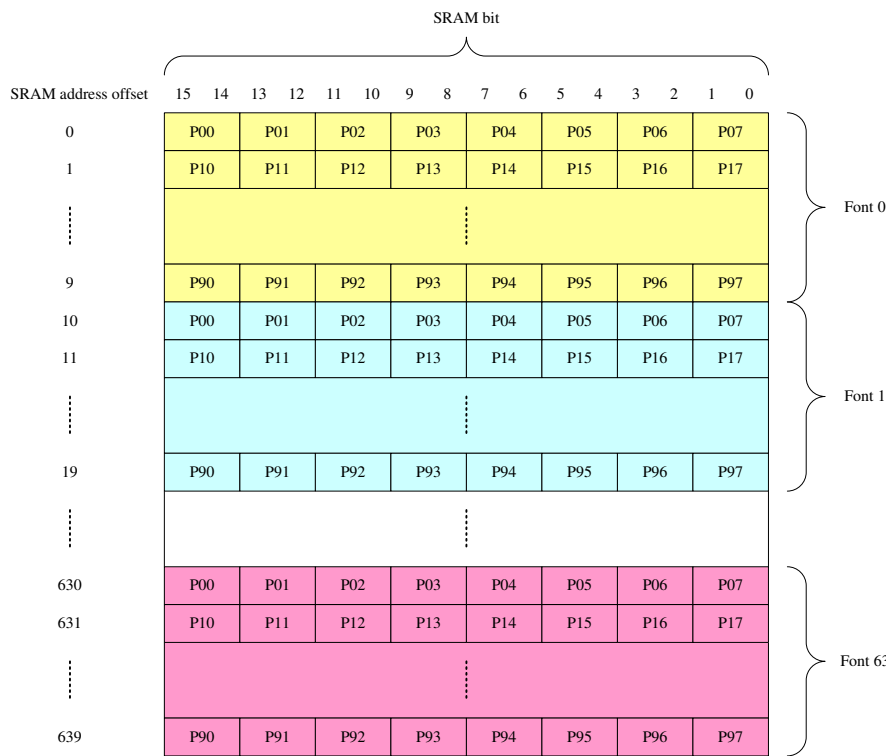

PICTURE

The picture is used for channel status. Each channel has picture display. The picture size in SRAM is fixed to 32x32. The display picture size is also fixed to 32x32. Same as font, it uses 2 bits for picture color. So there are four colors which can be set by registers: OSD_PIC_R0 (G0, B0), OSD_PIC_R1 (G1, B1), OSD_PIC_R2 (G2, B2) and OSD_PIC_R3 (G3, B3). There are four pictures saved in SRAM. Data in SRAM are same as fonts. Data are saved picture by picture. And in one picture, data are line by line. In one byte data, pixel data is stored in big endian. There are totally $32 \times 32 \times 4 \times 2 = 512 \times 16$ bits in SRAM.

Display Information

CHANNEL NUMBER

For each channel, there is a 8-font channel number information. Each font is selected from 64-font table. So index for each font is 6 bit. Channel number can be enabled by setting register OSD_CHNUM_EN and OSD_EN to high. Channel number can be mixed with video data by setting register OSD_CHNUM_MIX to high. Mix percentage is 50% video plus 50% channel number. The positions for each channel are same. They can be in four positions: left top, right top, left bottom and right bottom. It is set by register OSD_CHNUM_POS. For each position, horizontal offset and vertical offset can be set by OSD_CHNUM_HPOS and OSD_CHNUM_VPOS. For each position, the meaning for HPOS and VPOS is different because each channel size may be different.

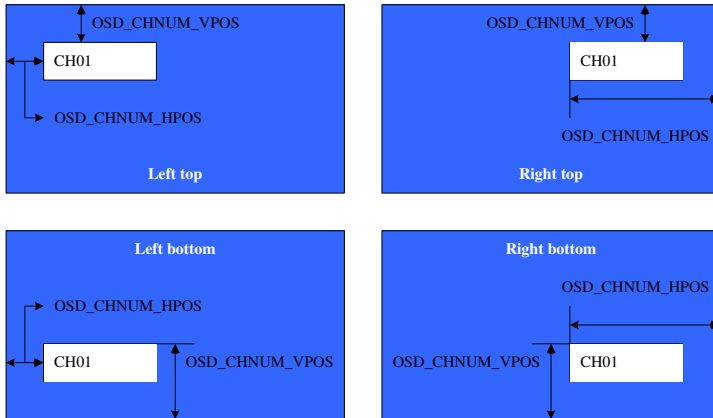

If channel number information has less than 8 fonts, you can set the remaining font to space. So you need to put space font in the 64-font table.

The font size can be changed according to register OSD_FONT_HSIZE and OSD_FONT_VSIZE. But remember the fonts saved in memory are always 8x10. If double size is selected, just repeat every pixel twice.

Channel information for display is saved in display SRAM. It contains 32x8x6=256x6. The sequence is channel by channel. In each channel, the sequence is font by font. SRAM is shown below:

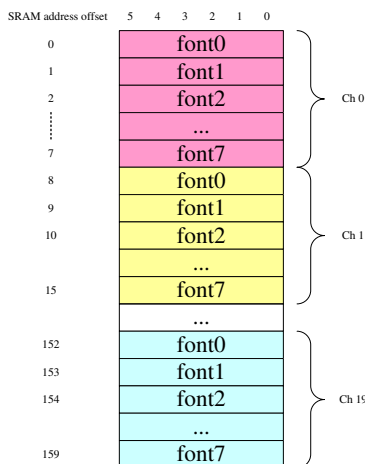

CHANNEL PICTURE

For each channel, there is a picture which can show channel status such as no camera. It can be enabled by setting register OSD_CHPIC_EN and OSD_EN to high. The picture can also be mixed with video by setting register OSD_CHPIC_MIX. The mix method is 50% video and 50% picture. If you want to make some pixels transparent, you can set OSD_CHPIC_TRANS to high. The pixels in color index "00" will be transparent. There is a blink option. If

OSD_CHPIC_BLINK is high, picture index 00 and 01 will not blink, and picture index “10” and “11” will blink. So if you put “no video” picture in picture index “10” or “11”, these pictures will blink every 32 frames.

Picture index information for each channel will be saved in SRAM. It needs totally 32x2=64 bits. But for design easily, we use 32x6 bits. Each 6 bit is for each channel, but only LSB 2 bits are used.

Picture position can also be programmed same as channel number. The register setting is shown below.



DATE AND TIME

Date and time are only display once on whole screen, not channel by channel. There are totally 32 fonts can be displayed including space. Like other display information, the position for date and time can be programmed. And it can also be disabled and be mixed with video. The font index is saved in display SRAM. It needs 32x6 bits.

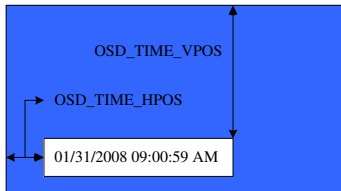

TITLE

Title is same as date and time. It has 32 fonts. It needs 32x6 SRAM size.

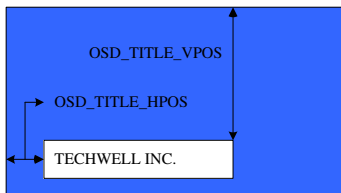

SRAM Allocation

There are two SRAM blocks in this design. One is for font and picture. The other is for display information.

FONT AND PICTURE SRAM

Font and picture are saved in one SRAM block. Font needs 640x16 bits, and picture needs 512x16 bits. So the total SRAM size is 1152x16 bits.

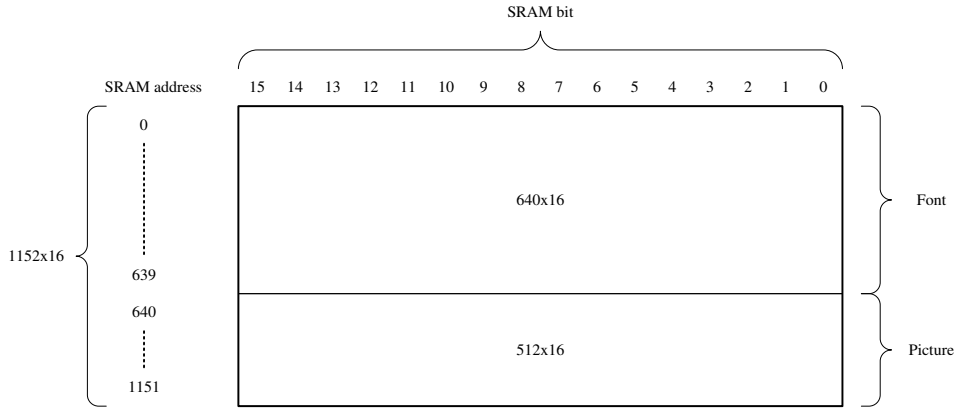

During system initialization, host need to write font and picture data in this SRAM. The write sequence is:

1. OSD_FRAM_ADDR[7:0]
2. OSD_FRAM_ADDR[10:0]
3. OSD_FRAM_DATA[7:0]
4. OSD_FRAM_DATA[15:8]

OSD_FRAM_DATA[15:8] must be the last one.

DISPLAY SRAM

Display SRAM includes channel number, channel picture, date/time and title information. Channel number needs 32x8x6=256 bits, channel picture needs 32x6 bits, date/time needs 32x6 bits and title needs 32x6 bits. So the total SRAM size is 352x6 bits.

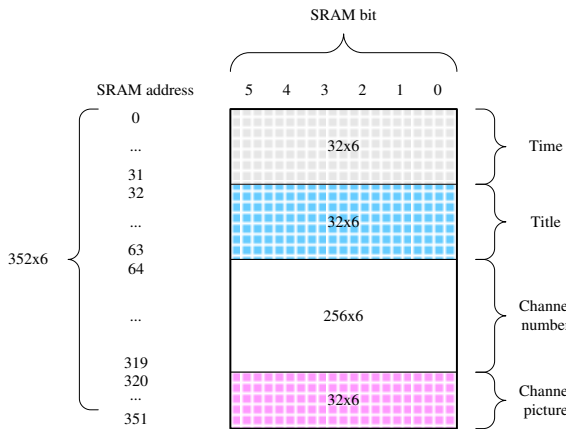

During display, host need to write index data in this SRAM. The write sequence is:

Set OSD_DRAM_ADDR, and then set OSD_DRAM_DATA.

In SPOT simple OSD, display SRAM needs 208x6bits:

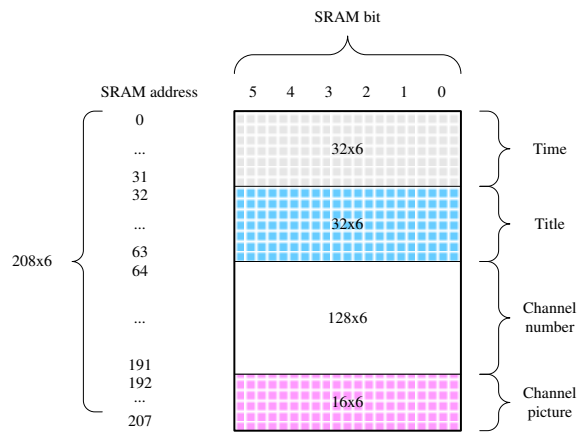

Registers Table

Address	R/W	Default	Description
0x180	R/W	0	[4]: OSD_TITLE_EN [3]: OSD_TIME_EN [2]: OSD_CHPIC_EN [1]: OSD_CHNUM_EN [0]: OSD_EN
0x181	R/W	0	[5]: OSD_CHPIC_BLINK [4]: OSD_CHPIC_TRANS [3]: OSD_TITLE_MIX [2]: OSD_TIME_MIX [1]: OSD_CHPIC_MIX [0]: OSD_CHNUM_MIX
0x182	R/W	0x4F	[7:6]: OSD_CHPIC_POS [5:4]: OSD_CHNUM_POS [3:2]: OSD_FONT_VSIZE [1:0]: OSD_FONT_HSIZE
0x183	R/W	0	OSD_CHNUM_HPOS[7:0]
0x184	R/W	0	OSD_CHNUM_HPOS[10:8]
0x185	R/W	0	OSD_CHNUM_VPOS[7:0]
0x186	R/W	0	OSD_CHNUM_VPOS[10:8]
0x187	R/W	0	OSD_CHPIC_HPOS[7:0]
0x188	R/W	0	OSD_CHPIC_HPOS[10:8]
0x189	R/W	0	OSD_CHPIC_VPOS[7:0]
0x18A	R/W	0	OSD_CHPIC_VPOS[10:8]
0x18B	R/W	0	OSD_TIME_HPOS[7:0]
0x18C	R/W	0	OSD_TIME_HPOS[10:8]
0x18D	R/W	0	OSD_TIME_VPOS[7:0]
0x18E	R/W	0	OSD_TIME_VPOS[10:8]
0x18F	R/W	0	OSD_TITLE_HPOS[7:0]
0x190	R/W	0	OSD_TITLE_HPOS[10:8]
0x191	R/W	0	OSD_TITLE_VPOS[7:0]
0x192	R/W	0	OSD_TITLE_VPOS[10:8]
0x193	R/W	0	OSD_FONT_R1[7:0]
0x194	R/W	0	OSD_FONT_G1[7:0]
0x195	R/W	0	OSD_FONT_B1[7:0]
0x196	R/W	0	OSD_FONT_R2[7:0]
0x197	R/W	0	OSD_FONT_G2[7:0]
0x198	R/W	0	OSD_FONT_B2[7:0]
0x199	R/W	0	OSD_FONT_R3[7:0]
0x19A	R/W	0	OSD_FONT_G3[7:0]
0x19B	R/W	0	OSD_FONT_B3[7:0]
0x19C	R/W	0	OSD_PIC_R0[7:0]
0x19D	R/W	0	OSD_PIC_G0[7:0]
0x19E	R/W	0	OSD_PIC_B0[7:0]
0x19F	R/W	0	OSD_PIC_R1[7:0]
0x1A0	R/W	0	OSD_PIC_G1[7:0]
0x1A1	R/W	0	OSD_PIC_B1[7:0]
0x1A2	R/W	0	OSD_PIC_R2[7:0]
0x1A3	R/W	0	OSD_PIC_G2[7:0]
0x1A4	R/W	0	OSD_PIC_B2[7:0]
0x1A5	R/W	0	OSD_PIC_R3[7:0]
0x1A6	R/W	0	OSD_PIC_G3[7:0]

Address	R/W	Default	Description
0x1A7	R/W	0	OSD_PIC_B3[7:0]
0x1A8	W	0	OSD_FRAM_ADDR[7:0]
0x1A9	W	0	OSD_FRAM_ADDR[10:8]
0x1AA	W	0	OSD_FRAM_DATA[7:0]
0x1AB	W	0	OSD_FRAM_DATA[15:8]
0x1AC	W	0	OSD_DRAM_ADDR[7:0]
0x1AD	W	0	OSD_DRAM_ADDR[8]
0x1AE	W	0	OSD_DRAM_DATA[5:0]

Registers Description

OSD CONTROL REGISTER – 0X180

Bit	R/W	Default	Description
4	RW	0	OSD_TITLE_EN Display title enable 1: enable 0: disable
3	RW	0	OSD_TIME_EN Display time and date enable 1: enable 0: disable
2	RW	0	OSD_CHPIC_EN Display picture for each channel 1: enable 0: disable
1	RW	0	OSD_CHNUM_EN Display channel number for each channel 1: enable 0: disable
0	RW	0	OSD_EN All OSD information enable or disable. If set to 1, each information is enabled by bit [4:1]. If set to 0, all OSD is disabled. 1: enable 0: disable

OSD MODE REGISTER – 0X181

Bit	R/W	Default	Description
5	RW	0	OSD_CHPIC_BLINK If set to 1, picture for each channel blink in picture index 2 and 3. Picture 0 and 1 will not blink 1: enable 0: disable
4	RW	0	OSD_CHPIC_TRANS If set to 1, picture in color index "00" will be transparent 1: enable 0: disable
3	RW	0	OSD_TITLE_MIX Display title mix enable bit. If set to 1, title will be 50% blending with video 1: enable 0: disable

Bit	R/W	Default	Description
2	RW	0	OSD_TIME_MIX Display time and date mix enable bit. If set to 1, time/date will be 50% blending with video 1: enable 0: disable
1	RW	0	OSD_CHPIC_MIX Display picture mix enable bit. If set to 1, picture will be 50% blending with video 1: enable 0: disable
0	RW	0	OSD_CHNUM_MIX Display channel number information mix enable bit. If set to 1, channel information will be 50% blending with video 1: enable 0: disable

OSD FONT SIZE REGISTER – 0X182

Bit	R/W	Default	Description
7:6	RW	0x1	OSD_CHPIC_POS : Channel picture corner position. 00: left top 01: right top 10: left bottom 11: right bottom
5:4	RW	0	OSD_CHNUM_POS : Channel number corner position. 00: left top 01: right top 10: left bottom 11: right bottom
3:2	RW	0x3	OSD_FONT_VSIZE : Font vertical size for display. There are four choices. 00: 8 01: 10 10: 16, scale up from 8 11: 20, scale up from 10
1:0	RW	0x3	OSD_FONT_HSIZE : Font horizontal size for display. There are four choices. 00: 6 01: 8 10: 12, scale up from 6 11: 16, scale up from 8

OSD CHANNEL NUMBER HORIZONTAL POSITION LOW BYTE REGISTER – 0X183

Bit	R/W	Default	Description
7:0	RW	0	OSD_CHNUM_HPOS[7:0] Channel number information horizontal position offset to each channel horizontal start position. It is one pixel unit.

OSD CHANNEL NUMBER HORIZONTAL POSITION HIGH BYTE REGISTER – 0X184

Bit	R/W	Default	Description
2:0	RW	0	OSD_CHNUM_HPOS[10:8] Channel number information horizontal position offset to each channel horizontal start position. It is one pixel unit.

OSD CHANNEL NUMBER VERTICAL POSITION LOW BYTE REGISTER – 0X185

Bit	R/W	Default	Description
7:0	RW	0	OSD_CHNUM_VPOS[7:0] Channel number information vertical position offset to each channel vertical start position. It is one pixel unit.

OSD CHANNEL NUMBER HORIZONTAL POSITION HIGH BYTE REGISTER – 0X186

Bit	R/W	Default	Description
2:0	RW	0	OSD_CHNUM_VPOS[10:8] Channel number information vertical position offset to each channel vertical start position. It is one pixel unit.

OSD CHANNEL PICTURE HORIZONTAL POSITION LOW BYTE REGISTER – 0X187

Bit	R/W	Default	Description
7:0	RW	0	OSD_CHPIC_HPOS[7:0] Channel picture information horizontal position offset to each channel horizontal start position. It is one pixel unit.

OSD CHANNEL PICTURE HORIZONTAL POSITION HIGH BYTE REGISTER – 0X188

Bit	R/W	Default	Description
2:0	RW	0	OSD_CHPIC_HPOS[10:8] Channel picture information horizontal position offset to each channel horizontal start position. It is one pixel unit.

OSD CHANNEL PICTURE VERTICAL POSITION LOW BYTE REGISTER – 0X189

Bit	R/W	Default	Description
7:0	RW	0	OSD_CHPIC_VPOS[7:0] Channel picture information vertical position offset to each channel vertical start position. It is one pixel unit.

OSD CHANNEL PICTURE HORIZONTAL POSITION HIGH BYTE REGISTER – 0X18A

Bit	R/W	Default	Description
2:0	RW	0	OSD_CHPIC_VPOS[10:8] Channel number information vertical position offset to each channel vertical start position. It is one pixel unit.

OSD TIME AND DATE HORIZONTAL POSITION LOW BYTE REGISTER – 0X18B

Bit	R/W	Default	Description
7:0	RW	0	OSD_TIME_HPOS[7:0] Time and Date information horizontal position. It is one pixel unit.

OSD TIME AND DATE HORIZONTAL POSITION HIGH BYTE REGISTER – 0X18C

Bit	R/W	Default	Description
2:0	RW	0	OSD_TIME_HPOS[10:8] Time and Date information horizontal position. It is one pixel unit.

OSD TIME AND DATE VERTICAL POSITION LOW BYTE REGISTER – 0X18D

Bit	R/W	Default	Description
7:0	RW	0	OSD_TIME_VPOS[7:0] Time and Date information vertical position. It is one pixel unit.

OSD TIME AND DATE HORIZONTAL POSITION HIGH BYTE REGISTER – 0X18E

Bit	R/W	Default	Description
2:0	RW	0	OSD_TIME_VPOS[10:8] Time and Date information vertical position. It is one pixel unit.

OSD TITLE HORIZONTAL POSITION LOW BYTE REGISTER – 0X18F

Bit	R/W	Default	Description
7:0	RW	0	OSD_TITLE_HPOS[7:0] Title information horizontal position. It is one pixel unit.

OSD TITLE HORIZONTAL POSITION HIGH BYTE REGISTER – 0X190

Bit	R/W	Default	Description
2:0	RW	0	OSD_TITLE_HPOS[10:8] Title information horizontal position. It is one pixel unit.

OSD TITLE VERTICAL POSITION LOW BYTE REGISTER – 0X191

Bit	R/W	Default	Description
7:0	RW	0	OSD_TITLE_VPOS[7:0] Title information vertical position. It is one pixel unit.

OSD TITLE HORIZONTAL POSITION HIGH BYTE REGISTER – 0X192

Bit	R/W	Default	Description
2:0	RW	0	OSD_TITLE_VPOS[10:8] Title information vertical position. It is one pixel unit.

OSD FONT RED COLOR 1 REGISTER – 0X193

Bit	R/W	Default	Description
7:0	RW	0	OSD_FONT_R1[7:0] Font red color for color index 1.

OSD FONT GREEN COLOR 1 REGISTER – 0X194

Bit	R/W	Default	Description
7:0	RW	0	OSD_FONT_G1[7:0] Font green color for color index 1.

OSD FONT BLUE COLOR 1 REGISTER – 0X195

Bit	R/W	Default	Description
7:0	RW	0	OSD_FONT_B1[7:0] Font blue color for color index 1.

OSD FONT RED COLOR 2 REGISTER – 0X196

Bit	R/W	Default	Description
7:0	RW	0	OSD_FONT_R2[7:0] Font red color for color index 2.

OSD FONT GREEN COLOR 2 REGISTER – 0X197

Bit	R/W	Default	Description
7:0	RW	0	OSD_FONT_G2[7:0] Font green color for color index 2.

OSD FONT BLUE COLOR 2 REGISTER – 0X198

Bit	R/W	Default	Description
7:0	RW	0	OSD_FONT_B2[7:0] Font blue color for color index 2.

OSD FONT RED COLOR 3 REGISTER – 0X199

Bit	R/W	Default	Description
7:0	RW	0	OSD_FONT_R3[7:0] Font red color for color index 3.

OSD FONT GREEN COLOR 3 REGISTER – 0X19A

Bit	R/W	Default	Description
7:0	RW	0	OSD_FONT_G3[7:0] Font green color for color index 3.

OSD FONT BLUE COLOR 3 REGISTER – 0X19B

Bit	R/W	Default	Description
7:0	RW	0	OSD_FONT_B3[7:0] Font blue color for color index 3.

OSD PICTURE RED COLOR 0 REGISTER – 0X19C

Bit	R/W	Default	Description
7:0	RW	0	OSD_PIC_R0[7:0] Picture red color for color index 0.

OSD PICTURE GREEN COLOR 0 REGISTER – 0X19D

Bit	R/W	Default	Description
7:0	RW	0	OSD_PIC_G0[7:0] Picture green color for color index 0.

OSD PICTURE BLUE COLOR 0 REGISTER – 0X19E

Bit	R/W	Default	Description
7:0	RW	0	OSD_PIC_B0[7:0] Picture blue color for color index 0.

OSD PICTURE RED COLOR 1 REGISTER – 0X19F

Bit	R/W	Default	Description
7:0	RW	0	OSD_PIC_R1[7:0] Picture red color for color index 1.

OSD PICTURE GREEN COLOR 1 REGISTER – 0X1A0

Bit	R/W	Default	Description
7:0	RW	0	OSD_PIC_G1[7:0] Picture green color for color index 1.

OSD PICTURE BLUE COLOR 1 REGISTER – 0X1A1

Bit	R/W	Default	Description
7:0	RW	0	OSD_PIC_B1[7:0] Picture blue color for color index 1.

OSD PICTURE RED COLOR 2 REGISTER – 0X1A2

Bit	R/W	Default	Description
7:0	RW	0	OSD_PIC_R2[7:0] Picture red color for color index 2.

OSD PICTURE GREEN COLOR 2 REGISTER – 0X1A3

Bit	R/W	Default	Description
7:0	RW	0	OSD_PIC_G2[7:0] Picture green color for color index 2.

OSD PICTURE BLUE COLOR 2 REGISTER – 0X1A4

Bit	R/W	Default	Description
7:0	RW	0	OSD_PIC_B2[7:0] Picture blue color for color index 2.

OSD PICTURE RED COLOR 3 REGISTER – 0X1A5

Bit	R/W	Default	Description
7:0	RW	0	OSD_PIC_R3[7:0] Picture red color for color index 3.

OSD PICTURE GREEN COLOR 3 REGISTER – 0X1A6

Bit	R/W	Default	Description
7:0	RW	0	OSD_PIC_G3[7:0] Picture green color for color index 3.

OSD PICTURE BLUE COLOR 3 REGISTER – 0X1A7

Bit	R/W	Default	Description
7:0	RW	0	OSD_PIC_B3[7:0] Picture blue color for color index 3.

OSD FONT AND PICTURE RAM ADDRESS LOW BYTE REGISTER – 0X1A8

Bit	R/W	Default	Description
7:0	RW	0	OSD_FRAM_ADDR[7:0] Font and Picture SRAM address. When host write data to this SRAM, address is written first and then data. SRAM size is 1152x16. Font size is 640x16, Picture size is 512x16.

OSD FONT AND PICTURE RAM ADDRESS HIGH BYTE REGISTER – 0X1A9

Bit	R/W	Default	Description
2:0	RW	0	OSD_FRAM_ADDR[10:8] Font and Picture SRAM address. When host write data to this SRAM, address is written first and then data. SRAM size is 1152x16. Font size is 640x16, Picture size is 512x16.

OSD FONT AND PICTURE RAM DATA LOW BYTE REGISTER – 0X1AA

Bit	R/W	Default	Description
7:0	RW	0	OSD_FRAM_DATA[7:0] Font and Picture SRAM address. When host write data to this SRAM, address is written first and then data. SRAM size is 1152x16. Font size is 640x16, Picture size is 512x16.

OSD FONT AND PICTURE RAM DATA HIGH BYTE REGISTER – 0X1AB

Bit	R/W	Default	Description
7:0	RW	0	OSD_FRAM_DATA[15:8] Font and Picture SRAM address. When host write data to this SRAM, address is written first and then data. SRAM size is 1152x16. Font size is 640x16, Picture size is 512x16.

OSD DISPLAY RAM ADDRESS REGISTER – 0X1AC

Bit	R/W	Default	Description
7:0	RW	0	OSD_DRAM_ADDR[7:0] Display SRAM address. When host write data to this SRAM, address is written first and then data. SRAM size is 244x6. Channel number size is 160x6, time/date size is 32x6, title size is 32x6 and picture index size is 20x6.

OSD DISPLAY RAM ADDRESS REGISTER – 0X1AD

Bit	R/W	Default	Description
7:0	RW	0	OSD_DRAM_ADDR[8] Display SRAM address. When host write data to this SRAM, address is written first and then data. SRAM size is 244x6. Channel number size is 160x6, time/date size is 32x6, title size is 32x6 and picture index size is 20x6.

OSD DISPLAY RAM DATA REGISTER – 0X1AE

Bit	R/W	Default	Description
7:0	RW	0	OSD_DRAM_Data[5:0] Display SRAM Data. When host write data to this SRAM, address is written first and then data. SRAM size is 244x6. Channel number size is 160x6, time/date size is 32x6, title size is 32x6 and picture index size is 20x6.

Registers Description

OSD CONTROL REGISTER – 0X180

Bit	R/W	Default	Description
4	RW	0	OSD_TITLE_EN Display title enable 1: enable 0: disable
3	RW	0	OSD_TIME_EN Display time and date enable 1: enable 0: disable
2	RW	0	OSD_CHPIC_EN Display picture for each channel 1: enable 0: disable
1	RW	0	OSD_CHNUM_EN Display channel number for each channel 1: enable 0: disable
0	RW	0	OSD_EN All OSD information enable or disable. If set to 1, each information is enabled by bit [4:1]. If set to 0, all OSD is disabled. 1: enable 0: disable

OSD MODE REGISTER – 0X181

Bit	R/W	Default	Description
5	RW	0	OSD_CHPIC_BLINK If set to 1, picture for each channel blink in picture index 2 and 3. Picture 0 and 1 will not blink 1: enable 0: disable
4	RW	0	OSD_CHPIC_TRANS If set to 1, picture in color index "00" will be transparent 1: enable 0: disable
3	RW	0	OSD_TITLE_MIX Display title mix enable bit. If set to 1, title will be 50% blending with video 1: enable 0: disable

Bit	R/W	Default	Description
2	RW	0	OSD_TIME_MIX Display time and date mix enable bit. If set to 1, time/date will be 50% blending with video 1: enable 0: disable
1	RW	0	OSD_CHPIC_MIX Display picture mix enable bit. If set to 1, picture will be 50% blending with video 1: enable 0: disable
0	RW	0	OSD_CHNUM_MIX Display channel number information mix enable bit. If set to 1, channel information will be 50% blending with video 1: enable 0: disable

OSD FONT SIZE REGISTER – 0X182

Bit	R/W	Default	Description
7:6	RW	0x1	OSD_CHPIC_POS Channel picture corner position. 00: left top 01: right top 10: left bottom 11: right bottom
5:4	RW	0	OSD_CHNUM_POS Channel number corner position. 00: left top 01: right top 10: left bottom 11: right bottom
3:2	RW	0x3	OSD_FONT_VSIZE Font vertical size for display. There are four choices. 00: 8 01: 10 10: 16, scale up from 8 11: 20, scale up from 10
1:0	RW	0x3	OSD_FONT_HSIZE Font horizontal size for display. There are four choices. 00: 6 01: 8 10: 12, scale up from 6 11: 16, scale up from 8

OSD CHANNEL NUMBER HORIZONTAL POSITION LOW BYTE REGISTER – 0X183

Bit	R/W	Default	Description
7:0	RW	0	OSD_CHNUM_HPOS[7:0] Channel number information horizontal position offset to each channel horizontal start position. It is one pixel unit.

OSD CHANNEL NUMBER HORIZONTAL POSITION HIGH BYTE REGISTER – 0X184

Bit	R/W	Default	Description
2:0	RW	0	OSD_CHNUM_HPOS[10:8] Channel number information horizontal position offset to each channel horizontal start position. It is one pixel unit.

OSD CHANNEL NUMBER VERTICAL POSITION LOW BYTE REGISTER – 0X185

Bit	R/W	Default	Description
7:0	RW	0	OSD_CHNUM_VPOS[7:0] Channel number information vertical position offset to each channel vertical start position. It is one pixel unit.

OSD CHANNEL NUMBER HORIZONTAL POSITION HIGH BYTE REGISTER – 0X186

Bit	R/W	Default	Description
2:0	RW	0	OSD_CHNUM_VPOS[10:8] Channel number information vertical position offset to each channel vertical start position. It is one pixel unit.

OSD CHANNEL PICTURE HORIZONTAL POSITION LOW BYTE REGISTER – 0X187

Bit	R/W	Default	Description
7:0	RW	0	OSD_CHPIC_HPOS[7:0] Channel picture information horizontal position offset to each channel horizontal start position. It is one pixel unit.

OSD CHANNEL PICTURE HORIZONTAL POSITION HIGH BYTE REGISTER – 0X188

Bit	R/W	Default	Description
2:0	RW	0	OSD_CHPIC_HPOS[10:8] Channel picture information horizontal position offset to each channel horizontal start position. It is one pixel unit.

OSD CHANNEL PICTURE VERTICAL POSITION LOW BYTE REGISTER – 0X189

Bit	R/W	Default	Description
7:0	RW	0	OSD_CHPIC_VPOS[7:0] Channel picture information vertical position offset to each channel vertical start position. It is one pixel unit.

OSD CHANNEL PICTURE HORIZONTAL POSITION HIGH BYTE REGISTER – 0X18A

Bit	R/W	Default	Description
2:0	RW	0	OSD_CHPIC_VPOS[10:8] Channel number information vertical position offset to each channel vertical start position. It is one pixel unit.

OSD TIME AND DATE HORIZONTAL POSITION LOW BYTE REGISTER – 0X18B

Bit	R/W	Default	Description
7:0	RW	0	OSD_TIME_HPOS[7:0] Time and Date information horizontal position. It is one pixel unit.

OSD TIME AND DATE HORIZONTAL POSITION HIGH BYTE REGISTER – 0X18C

Bit	R/W	Default	Description
2:0	RW	0	OSD_TIME_HPOS[10:8] Time and Date information horizontal position. It is one pixel unit.

OSD TIME AND DATE VERTICAL POSITION LOW BYTE REGISTER – 0X18D

Bit	R/W	Default	Description
7:0	RW	0	OSD_TIME_VPOS[7:0] Time and Date information vertical position. It is one pixel unit.

OSD TIME AND DATE HORIZONTAL POSITION HIGH BYTE REGISTER – 0X18E

Bit	R/W	Default	Description
2:0	RW	0	OSD_TIME_VPOS[10:8] Time and Date information vertical position. It is one pixel unit.

OSD TITLE HORIZONTAL POSITION LOW BYTE REGISTER – 0X18F

Bit	R/W	Default	Description
7:0	RW	0	OSD_TITLE_HPOS[7:0] Title information horizontal position. It is one pixel unit.

OSD TITLE HORIZONTAL POSITION HIGH BYTE REGISTER – 0X190

Bit	R/W	Default	Description
2:0	RW	0	OSD_TITLE_HPOS[10:8] Title information horizontal position. It is one pixel unit.

OSD TITLE VERTICAL POSITION LOW BYTE REGISTER – 0X191

Bit	R/W	Default	Description
7:0	RW	0	OSD_TITLE_VPOS[7:0] Title information vertical position. It is one pixel unit.

OSD TITLE HORIZONTAL POSITION HIGH BYTE REGISTER – 0X192

Bit	R/W	Default	Description
2:0	RW	0	OSD_TITLE_VPOS[10:8] Title information vertical position. It is one pixel unit.

OSD FONT RED COLOR 1 REGISTER – 0X193

Bit	R/W	Default	Description
7:0	RW	0	OSD_FONT_R1[7:0] Font red color for color index 1.

OSD FONT GREEN COLOR 1 REGISTER – 0X194

Bit	R/W	Default	Description
7:0	RW	0	OSD_FONT_G1[7:0] Font green color for color index 1.

OSD FONT BLUE COLOR 1 REGISTER – 0X195

Bit	R/W	Default	Description
7:0	RW	0	OSD_FONT_B1[7:0] Font blue color for color index 1.

OSD FONT RED COLOR 2 REGISTER – 0X196

Bit	R/W	Default	Description
7:0	RW	0	OSD_FONT_R2[7:0] Font red color for color index 2.

OSD FONT GREEN COLOR 2 REGISTER – 0X197

Bit	R/W	Default	Description
7:0	RW	0	OSD_FONT_G2[7:0] Font green color for color index 2.

OSD FONT BLUE COLOR 2 REGISTER – 0X198

Bit	R/W	Default	Description
7:0	RW	0	OSD_FONT_B2[7:0] Font blue color for color index 2.

OSD FONT RED COLOR 3 REGISTER – 0X199

Bit	R/W	Default	Description
7:0	RW	0	OSD_FONT_R3[7:0] Font red color for color index 3.

OSD FONT GREEN COLOR 3 REGISTER – 0X19A

Bit	R/W	Default	Description
7:0	RW	0	OSD_FONT_G3[7:0] Font green color for color index 3.

OSD FONT BLUE COLOR 3 REGISTER – 0X19B

Bit	R/W	Default	Description
7:0	RW	0	OSD_FONT_B3[7:0] Font blue color for color index 3.

OSD PICTURE RED COLOR 0 REGISTER – 0X19C

Bit	R/W	Default	Description
7:0	RW	0	OSD_PIC_R0[7:0] Picture red color for color index 0.

OSD PICTURE GREEN COLOR 0 REGISTER – 0X19D

Bit	R/W	Default	Description
7:0	RW	0	OSD_PIC_G0[7:0] Picture green color for color index 0.

OSD PICTURE BLUE COLOR 0 REGISTER – 0X19E

Bit	R/W	Default	Description
7:0	RW	0	OSD_PIC_B0[7:0] Picture blue color for color index 0.

OSD PICTURE RED COLOR 1 REGISTER – 0X19F

Bit	R/W	Default	Description
7:0	RW	0	OSD_PIC_R1[7:0] Picture red color for color index 1.

OSD PICTURE GREEN COLOR 1 REGISTER – 0X1A0

Bit	R/W	Default	Description
7:0	RW	0	OSD_PIC_G1[7:0] Picture green color for color index 1.

OSD PICTURE BLUE COLOR 1 REGISTER – 0X1A1

Bit	R/W	Default	Description
7:0	RW	0	OSD_PIC_B1[7:0] Picture blue color for color index 1.

OSD PICTURE RED COLOR 2 REGISTER – 0X1A2

Bit	R/W	Default	Description
7:0	RW	0	OSD_PIC_R2[7:0] Picture red color for color index 2.

OSD PICTURE GREEN COLOR 2 REGISTER – 0X1A3

Bit	R/W	Default	Description
7:0	RW	0	OSD_PIC_G2[7:0] Picture green color for color index 2.

OSD PICTURE BLUE COLOR 2 REGISTER – 0X1A4

Bit	R/W	Default	Description
7:0	RW	0	OSD_PIC_B2[7:0] Picture blue color for color index 2.

OSD PICTURE RED COLOR 3 REGISTER – 0X1A5

Bit	R/W	Default	Description
7:0	RW	0	OSD_PIC_R3[7:0] Picture red color for color index 3.

OSD PICTURE GREEN COLOR 3 REGISTER – 0X1A6

Bit	R/W	Default	Description
7:0	RW	0	OSD_PIC_G3[7:0] Picture green color for color index 3.

OSD PICTURE BLUE COLOR 3 REGISTER – 0X1A7

Bit	R/W	Default	Description
7:0	RW	0	OSD_PIC_B3[7:0] Picture blue color for color index 3.

OSD FONT AND PICTURE RAM ADDRESS LOW BYTE REGISTER – 0X1A8

Bit	R/W	Default	Description
7:0	RW	0	OSD_FRAM_ADDR[7:0] Font and Picture SRAM address. When host write data to this SRAM, address is written first and then data. SRAM size is 1152x16. Font size is 640x16, Picture size is 512x16.

OSD FONT AND PICTURE RAM ADDRESS HIGH BYTE REGISTER – 0X1A9

Bit	R/W	Default	Description
2:0	RW	0	OSD_FRAM_ADDR[10:8] Font and Picture SRAM address. When host write data to this SRAM, address is written first and then data. SRAM size is 1152x16. Font size is 640x16, Picture size is 512x16.

OSD FONT AND PICTURE RAM DATA LOW BYTE REGISTER – 0X1AA

Bit	R/W	Default	Description
7:0	RW	0	OSD_FRAM_DATA[7:0] Font and Picture SRAM address. When host write data to this SRAM, address is written first and then data. SRAM size is 1152x16. Font size is 640x16, Picture size is 512x16.

OSD FONT AND PICTURE RAM DATA HIGH BYTE REGISTER – 0X1AB

Bit	R/W	Default	Description
7:0	RW	0	OSD_FRAM_DATA[15:8] Font and Picture SRAM address. When host write data to this SRAM, address is written first and then data. SRAM size is 1152x16. Font size is 640x16, Picture size is 512x16.

OSD DISPLAY RAM ADDRESS REGISTER – 0X1AC

Bit	R/W	Default	Description
7:0	RW	0	OSD_DRAM_ADDR[7:0] Display SRAM address. When host write data to this SRAM, address is written first and then data. SRAM size is 352x6. Channel number size is 256x6, time/date size is 32x6, title size is 32x6 and picture index size is 32x6.

OSD DISPLAY RAM ADDRESS REGISTER – 0X1AD

Bit	R/W	Default	Description
0	RW	0	OSD_DRAM_ADDR[8] Display SRAM address. When host write data to this SRAM, address is written first and then data. SRAM size is 352x6. Channel number size is 256x6, time/date size is 32x6, title size is 32x6 and picture index size is 32x6.

OSD DISPLAY RAM DATA REGISTER – 0X1AE

Bit	R/W	Default	Description
7:0	RW	0	OSD_DRAM_Data[5:0] Display SRAM address. When host write data to this SRAM, address is written first and then data. SRAM size is 352x6. Channel number size is 256x6, time/date size is 32x6, title size is 32x6 and picture index size is 32x6.

Dualview Display Controller Unit

Introduction

In addition to the main display controller, TW2880 has a secondary display controller which can support display devices with interlaced or progressive timing. Using the integrated TV encoder and the DAC, this DualView display controller can drive traditional TV with CVBS or a progressive LCD display with VGA socket. With properly software registers setup and display memory planning between the two display controller, the sixteen input channels and sixteen playback channels can be displayed in many different resolutions and combinations between the two different monitors. (TW2880C cannot fully support main display is at 60 Hz and Dualview controller is set at NTSC standard, some channels may have tearing effect)

Because the bandwidth limitation from the display memory controller, the resolution and frame rate in this secondary controller is limited. The DualView display controller is able to support all NTSC and PAL standards for analog output, which can be composite video or S-Video for display.

Features

- Support NTSC / PAL standard TV monitor with integrated 10 bit DAC and TV encoder
- Support LCD monitor (up to 1080p)
- Down scaling from 1920x1080 resolution
- Support same or different video content with main display
- Two OSG layers, each layer has four sub-window
- Two OSG layers support different upscale ratio
- Support same or different OSG content with main display
- Two mouse layers on screen
- Support 16 mouse shape in SDRAM
- Four single boxes
- Support main display to CVBS output
- Support 16 live channels and 16 play back channels
- Support simple OSG for 32 channels

Dual Monitor Controller Architecture

For the controller to display the video channels on the main LCD screen and on the other CRT / LCD screen, the memory location need to be programmed for the controller to fetch data at the right area, Firmware needs to set the second monitor starting address, size, down scale factors, TV parameters control registers for the CRT monitor to display properly.

MEMORY DIAGRAM

The following picture shows the LCD and Dual monitor memory in SDRAM and some related registers. For the dual monitor start address, it can start anywhere by program the DM_HSTART and DM_VSTART address.

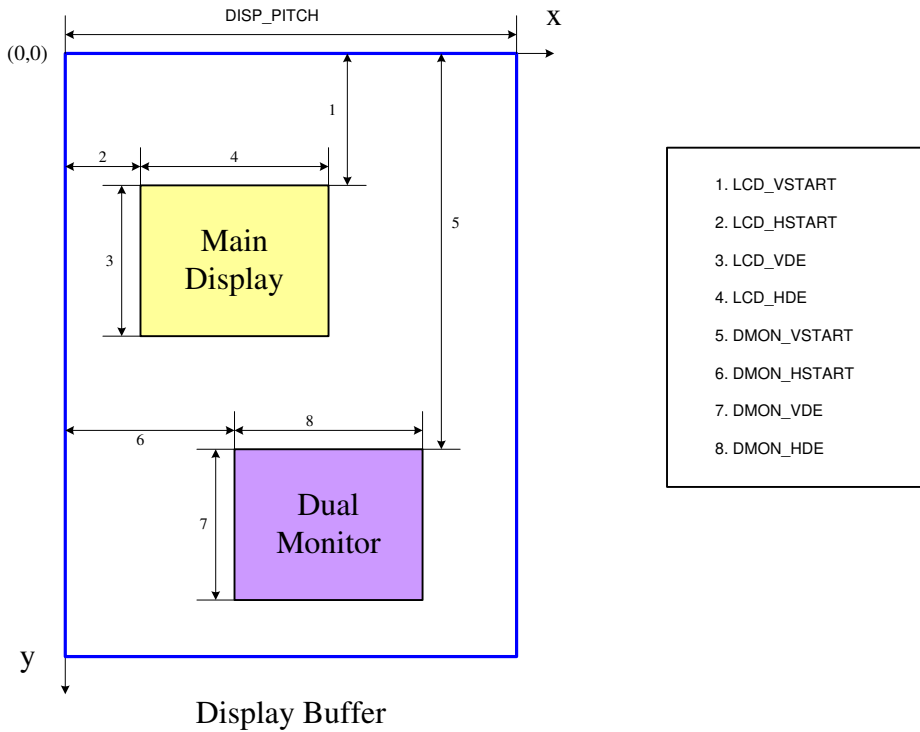

FRAME DATA SYNCHRONIZATION

To prevent the video tearing, the dual monitor controller takes use the frame rate synchronization circuit which will guarantee there are two frames difference between active display frame and active storing frame. If the frame rate of the Dual Monitor is higher than the incoming video pipe, frame repeating process is employed to make sure the two frame boundary is maintained.

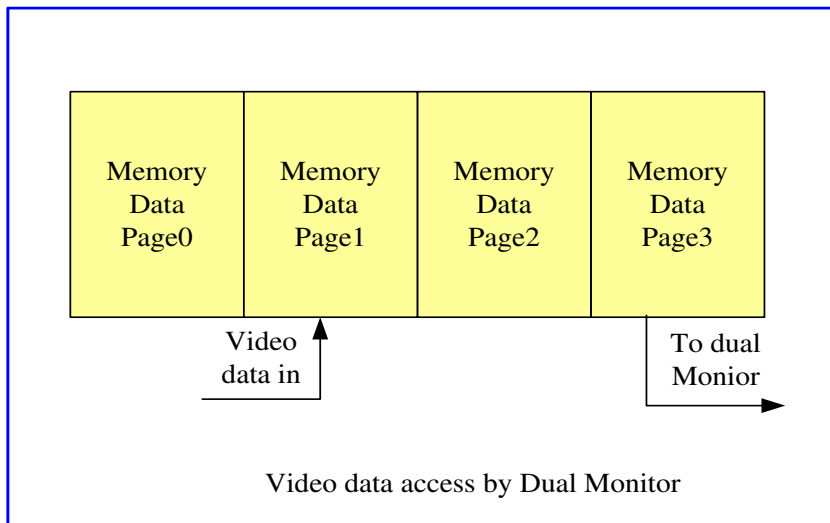

DUAL MONITOR CONTROLLER BLOCK DIAGRAM

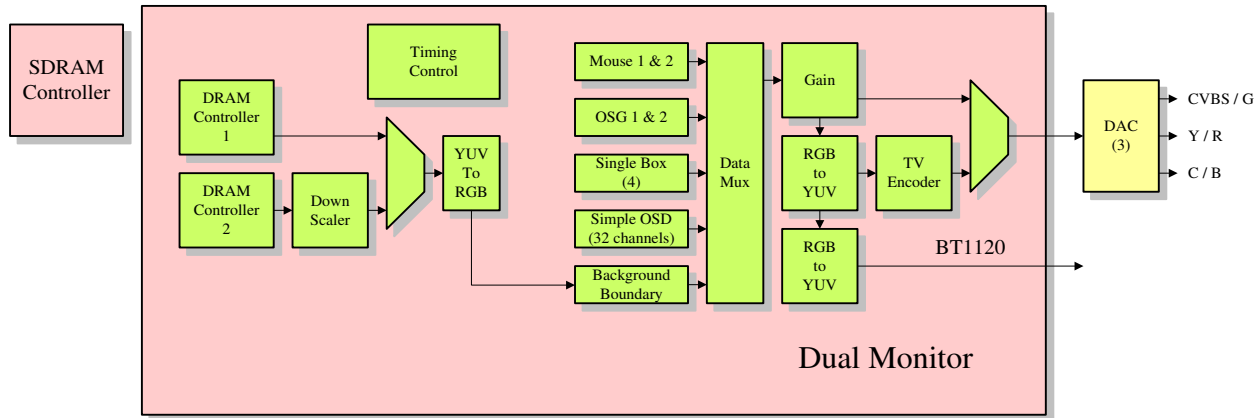

MEMORY INTERFACE

Based on the information of Horizontal and vertical timing, and under registers control, Memory Interface is a module uses to generate request to the DRAM controller and ask for the DRAM access to get the display data from the DRAM and send it the FIFO. There are two DRAM controller modules. One is for the case without down scaler. The other one is for the case with down scaler.

FIFO INTERFACE

Due to the memory clock and video clock running in different frequency, there is a 128 deep and 64 bit wide FIFO to synchronize the data for cross clock domain operation.

HV TIMING CONTROL

Base on the setting of horizontal and vertical registers and the inputs information of the TV Encoder, The HV timing control module generates all pixels, lines, and blanking signals and feed them to the Memory interface module to request data from DRAM.

Depends on the Odd or Even field indicator output from the TV, The Dram Interface module will generate the memory address in that field and fetches data from the line memory, and send to the Down Scale controller and processes the image according the scale factor and send it to the Line Buffers.

Due to the different timing requirement of the LCD panel and the TV, once a while, we may encounter minor display delay between two displays as the calculation shown below.

The Field period in the dual monitor is $1/59.95 = 16.68 \text{ ms}$

The Frame period in the LCD display is $1/60 = 16.667 \text{ ms}$

The different of the period is 0.05 mS that means every 20 seconds, there is a field data get from the same page in the memory and displays on the Dual Monitor.

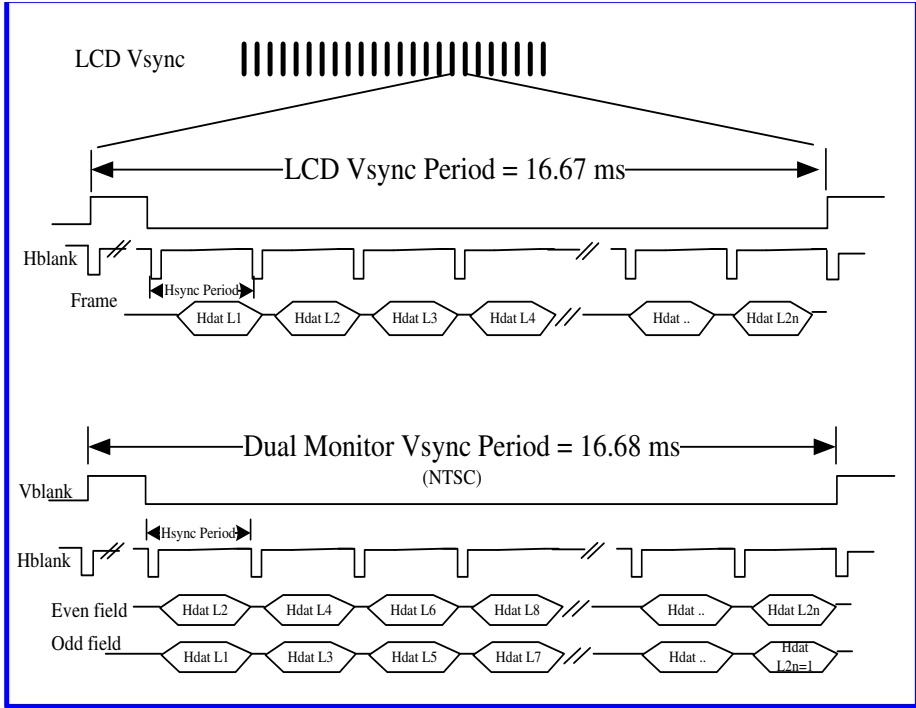

DOWN SCALAR

Down scalar is a module uses to scale down more channels on the display to fit the TV standard timing. So on the second monitor, we can pack as many channels as seen on the LCD and display them on a regular TV.

By using the linear interpolation technique, with independent setting of horizontal and vertical scale factors and others registers. We can scale the number of channels, the size and the location of the channels to the display's native resolution.

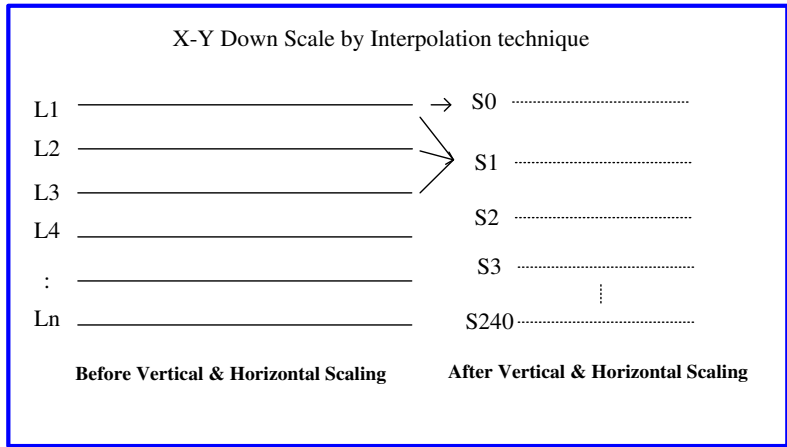

LINE BUFFER CONTROL

Due to the clock rate difference of the Down Scalar and the TV Encoder, there are two line buffers size of 1920x16 to accommodate the timing of the TV Encoder.

TV ENCODER

TV Encoder is the module converts all component data from scalar into a standard analog baseband television signal (CVBS) or S-Video signal which is compatible with worldwide standards. Follow is the PAL timing.

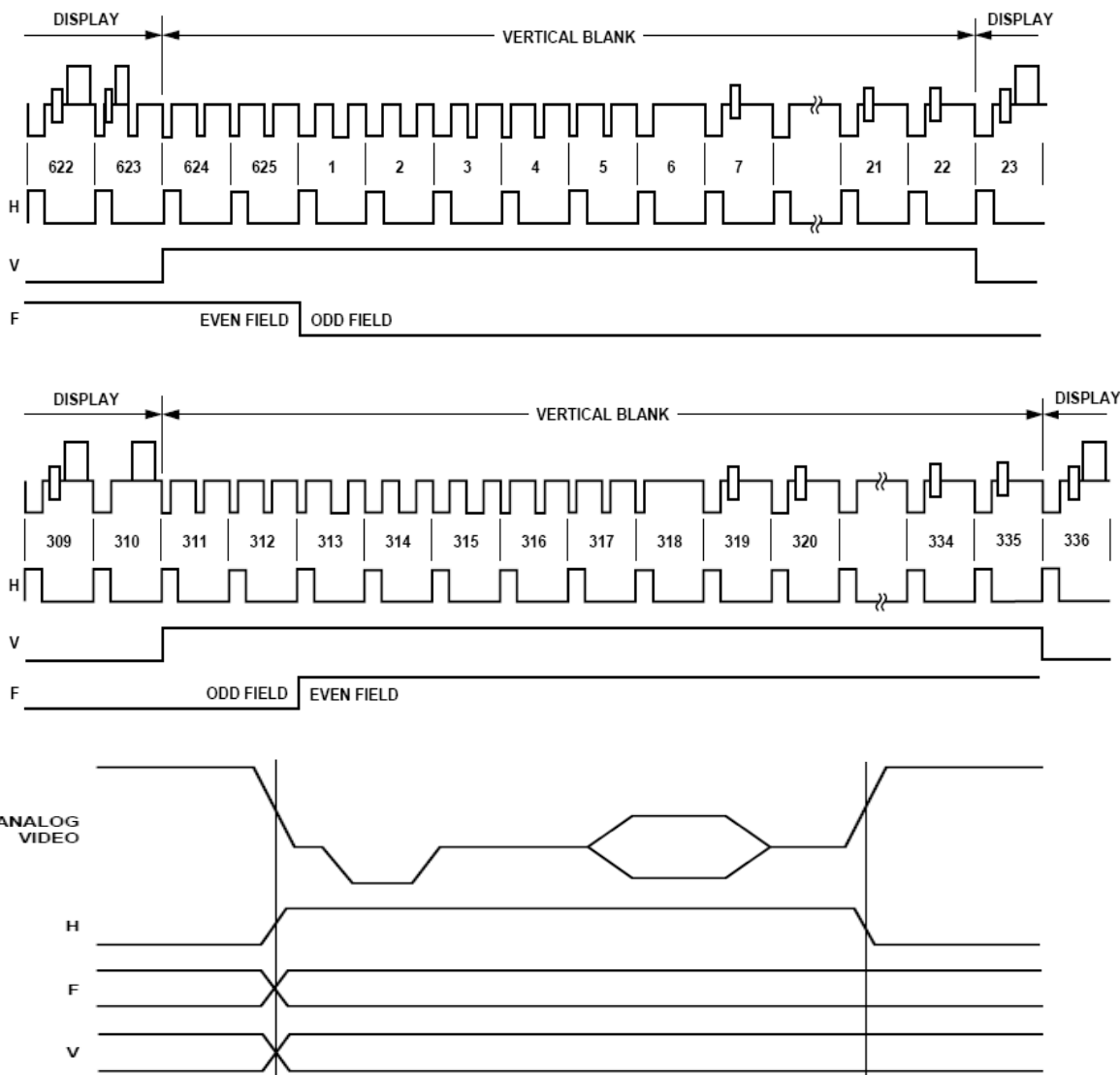

OSD CONTROL

Dual monitor use the same architecture and design as the OSD in the LCD display path.

With all DM_OSD control registers in the Dual monitor page, Firmware can set up the DM_OSD display as the same source as the LCD Main Display Port if the Dual monitor displays the same channels.

If the LCD Main Display Port and Dual monitor show different channels on two displays, each OSD will display the channel correspondent to its own cameras. In other words, different channels will be mapped to different OSD source accordingly.

For all the operation and programming of the DM_OSD registers, please refer to the “OSD for Display Path” section beginning on page 299 where the detailed explanation and operation are fully documented.

- 64 fonts table saved in SRAM
- Channel information table saved in SRAM
- Three lines channel information
- 32 characters date/time
- 16 characters channel title for each channel
- 16 characters channel status for each channel
- Font size can be changed in 6x8, 8x10, 12x16, 16x20

CLOCK SETTING FOR DUAL MONITOR

There are two clock for dual monitor need to be set correctly. One is `dm_vclk`, the other one is `dm_fclk`. "`dm_vclk`" is pixel clock. `Dm_fclk` is used for down scaler. When down scaler is used, `dm_fclk` must be bigger than `dm_vclk`. In worst case, $dm_fclk = dm_vclk * horizontal\ down\ scaler\ ratio * vertical\ down\ scale\ ratio$. But it also depends on horizontal blank time. If horizontal blank time is big, `dm_fclk` can be smaller.

THEORY OF OPERATION

When the Dual monitor controller is enabling, the controller can access the whole memory map and display the content with the start address set by the HSTART and the VSTART registers. Of course, if the setting is out of bound, the display will show something on the screen with no meaning at all. So for the controller to operate properly, some registers need to set.

`DM_HTT`, `DM_HDE`, `DM_VTT` and `DM_VDE` are based on pixel clock.

In NTSC mode, `dm_vclk` must be set to 13.5MHz.

`DM_HTT` = 857

`DM_HDE` = 719

`DM_VTT` = 261

`DM_VDE` = 239

In 1280x1024 VGA mode, `dm_vclk` must be set to 108MHz.

`DM_HTT` = 1687

`DM_HDE` = 1279

`DM_VTT` = 1065

`DM_VDE` = 1023

In 1920x1080 VGA mode, `dm_vclk` must be set to 148.5MHz.

`DM_HTT` = 2199

`DM_HDE` = 1920

`DM_VTT` = 1124

`DM_VDE` = 1079

`Dm_vclk` can be selected from 13.5M, 27M, 54M and 108M, or it can be divided by faster clock from `vpll`.

TV ENCODER SETTING

In NTSC mode, user need to set:

[0x71A] = 0x00

[0x71B] = 0x01

[0x71C] = 0x08

In PAL mode, user need to set:

[0x71A] = 0x05

[0x71B] = 0x41

[0x71C] = 0x08

Register Table

Address	R/W	Default	Description
0x700	R/W	0	DM_HTT[7:0]
0x701	R/W	0	DM_HTT[12:8]
0x702	R/W	0	DM_VTT[7:0]
0x703	R/W	0	DM_VTT[10:8]
0x704	R/W	0	DM_HDE[7:0]
0x705	R/W	0	DM_HDE[10:8]
0x706	R/W	0	DM_VDE[7:0]
0x707	R/W	0	DM_VDE[10:8]
0x708	R/W	0	DM_PHSYNC[7:0]
0x709	R/W	0	DM_PHSYNC[8]
0x70A	R/W	0	DM_PVSYNC[7:0]
0x70B	R/W	0	DM_HSPW[7:0]
0x70C	R/W	0	DM_VSPW[7:0]
0x70D	R/W	0	[7]: MDBOX_EN [6]: VTT_INV [5]: DM_INT_CBAR [4]: EVEN_REPEAT [3:0]: VSYNC_DLY
0x70E	R/W	0	TAR_W[7:0]
0x70F	R/W	0	TAR_W[10:8]
0x710	R/W	0	TAR_H[7:0]
0x711	R/W	0	TAR_H[10:8]
0x712	R/W	0	[6]: IN_16_MODE [5]: DM_YC_SWAP [4]: DM_MAIN [3]: DM_ENA [2]: DM_LCD [1]: DM_VSPOL [0]: DM_HSPOL
0x713	R/W	0	DM_HSTART[7:0]
0x714	R/W	0	DM_VSTART[7:0]
0x715	R/W	0	[5:4]: DM_HSTART[9:8] [3:0]: DM_VSTART[11:8]
0x716	R/W	0	SRC_W[7:0]
0x717	R/W	0	SRC_W[10:8]
0x718	R/W	0	SRC_H[7:0]
0x719	R/W	0	SRC_H[10:8]
0x71A	R/W	0	[7:6]: TVENC_FSC_MODE [5]: TVENC_SAT_LEVEL [4:3]: TVENC_CCIR_IN_SEL [2:1]: TVENC_IN_SEL [0]: TVENC_PALNT
0x71B	R/W	0	[7]: TVENC_VSPOL [6]: TVENC_HSENC [5]: TVENC_VSDET [4]: TVENC_PED [3]: TVENC_PDRST [2]: TVENC_PHALT [1]: TVENC_F_INV [0]: INTERLACE
0x71C	R/W	0x10	[6:5]: TVENC_YC_INV [4:2]: TVENC_OSENC

Address	R/W	Default	Description
			[1]: TVENC_FLDENCP [0]: TVENC_FLDDDET
0x71D	R/W	0	TVENC_HSENC[7:0]
0x71E	R/W	0	TVENC_HSENC[9:8]
0x71F	R/W	0	TVENC_VSENC[5:0]
0x720	R/W	0	TVENC_LINE_OS[4:0]
0x721	R/W	0	TVENC_PIXEL_OS[5:0]
0x722	R/W	0	[6]: TVENC_C_OFF_D [5:4]: TVENC_CBW_D [3:2]: TVENC_YBW_D [1:0]: TVENC_VIS_FLD_OS
0x723	R/W	0	[7]: TVENC_TST_FSC_FREE [6]: TVENC_T_CCIR_TIM [5]: TVENC_T_656_STD [4:0]: TVENC_VIS_LINE_OS
0x724	R/W	0	[4]: OSD_CH_EN_SEL [3]: NOVID_SWITCH_EN [2]: BND_CH_EN_SEL [1]: NO_DNS [0]: VGA_DIS
0x725	R/W	0	[2]: DM_PD_R [1]: DM_PD_G [0]: DM_PD_B
0x726	R/W	0	[0]: MOUSE_UPDATE_EN / MOUSE_UPDATE_BUSY
0x727	R/W	0x20	DNS_HBLANK[7:0]
0x728	R/W	0	BND_CH_EN[7:0]
0x729	R/W	0	BND_CH_EN[15:8]
0x72A	R/W	0	BND_CH_EN[23:16]
0x72B	R/W	0	BND_CH_EN[31:24]
0x72C	R/W	0	NOVID_R[7:0]
0x72D	R/W	0	NOVID_G[7:0]
0x72E	R/W	0xFF	NOVID_B[7:0]
0x72F	R/W	0	[4]: MOUSE_BUF [3:0]: MOUSE_INDEX
0x730	R/W	0	[4]: OSD_TITLE_EN [3]: OSD_TIME_EN [2]: OSD_CHPIC_EN [1]: OSD_CHNUM_EN [0]: OSD_EN
0x731	R/W	0	[5]: OSD_CHPIC_BLINK [4]: OSD_CHPIC_TRANS [3]: OSD_TITLE_MIX [2]: OSD_TIME_MIX [1]: OSD_CHPIC_MIX [0]: OSD_CHNUM_MIX
0x732	R/W	0x4F	[7:6]: OSD_CHPIC_POS [5:4]: OSD_CHNUM_POS [3:2]: OSD_FONT_VSIZE [1:0]: OSD_FONT_HSIZE
0x733	R/W	0	OSD_CHNUM_HPOS[7:0]
0x734	R/W	0	OSD_CHNUM_HPOS[10:8]
0x735	R/W	0	OSD_CHNUM_VPOS[7:0]
0x736	R/W	0	OSD_CHNUM_VPOS[10:8]
0x737	R/W	0	OSD_CHPIC_HPOS[7:0]

Address	R/W	Default	Description
0x738	R/W	0	OSD_CHPIC_HPOS[10:8]
0x739	R/W	0	OSD_CHPIC_VPOS[7:0]
0x73A	R/W	0	OSD_CHPIC_VPOS[10:8]
0x73B	R/W	0	OSD_TIME_HPOS[7:0]
0x73C	R/W	0	OSD_TIME_HPOS[10:8]
0x73D	R/W	0	OSD_TIME_VPOS[7:0]
0x73E	R/W	0	OSD_TIME_VPOS[10:8]
0x73F	R/W	0	OSD_TITLE_HPOS[7:0]
0x740	R/W	0	OSD_TITLE_HPOS[10:8]
0x741	R/W	0	OSD_TITLE_VPOS[7:0]
0x742	R/W	0	OSD_TITLE_VPOS[10:8]
0x743	R/W	0	OSD_FONT_R1[7:0]
0x744	R/W	0	OSD_FONT_G1[7:0]
0x745	R/W	0	OSD_FONT_B1[7:0]
0x746	R/W	0	OSD_FONT_R2[7:0]
0x747	R/W	0	OSD_FONT_G2[7:0]
0x748	R/W	0	OSD_FONT_B2[7:0]
0x749	R/W	0	OSD_FONT_R3[7:0]
0x74A	R/W	0	OSD_FONT_G3[7:0]
0x74B	R/W	0	OSD_FONT_B3[7:0]
0x74C	R/W	0	OSD_PIC_R0[7:0]
0x74D	R/W	0	OSD_PIC_G0[7:0]
0x74E	R/W	0	OSD_PIC_B0[7:0]
0x74F	R/W	0	OSD_PIC_R1[7:0]
0x750	R/W	0	OSD_PIC_G1[7:0]
0x751	R/W	0	OSD_PIC_B1[7:0]
0x752	R/W	0	OSD_PIC_R2[7:0]
0x753	R/W	0	OSD_PIC_G2[7:0]
0x754	R/W	0	OSD_PIC_B2[7:0]
0x755	R/W	0	OSD_PIC_R3[7:0]
0x756	R/W	0	OSD_PIC_G3[7:0]
0x757	R/W	0	OSD_PIC_B3[7:0]
0x758	W	0	OSD_FRAM_ADDR[7:0]
0x759	W	0	OSD_FRAM_ADDR[10:8]
0x75A	W	0	OSD_FRAM_DATA[7:0]
0x75B	W	0	OSD_FRAM_DATA[15:8]
0x75C	W	0	OSD_DRAM_ADDR[7:0]
0x75D	W	0	OSD_DRAM_ADDR[8]
0x75E	W	0	OSD_DRAM_DATA[5:0]
0x75F	R/W	0x03	[1]: MOUSE_REG_UPDATE [0]: OSG_REG_UPDATE
0x760	R/W	0	BAR[7:0]
0x761	R/W	0	BAG[7:0]
0x762	R/W	0	BAB[7:0]
0x763	R/W	0	[7]: SWITCH_EN [6]: COLBAR_EN [5]: GAIN_EN [4]: BND_EN [3:0]: BND_WIDTH
0x764	R/W	0	BND_R[7:0]
0x765	R/W	0	BND_G[7:0]
0x766	R/W	0	BND_B[7:0]
0x767	R/W	0	VTT_WIN[7:0]

Address	R/W	Default	Description
0X768	R/W	0	[2]: VTT_ADJUST [1]: VTT_ADJUST_MODE [0]: VTT_ADJUST_EN
0X769	RO	-	NEW_VTT_RGBW[7:0]
0X76A	RO	-	NEW_VTT_RGBW[11:8]
0X76B	RO	-	NEW_VTT[7:0]
0X76C	R/W	0	NEW_VTT[10:8]
0x76D	R/W	RO	[0]: VACTIVE
0x780	R/W	0x00	SBOX0_CTRL[4:0]
0x781	R/W	0x00	SBOX1_CTRL[4:0]
0x782	R/W	0x00	SBOX2_CTRL[4:0]
0x783	R/W	0x00	SBOX3_CTRL[4:0]
0x784	R/W	0x00	[7:6]: SBOX3_V_LINE [5:4]: SBOX3_H_LINE [3:2]: SBOX2_V_LINE [1:0]: SBOX2_H_LINE
0x785	R/W	0x00	[7:6]: SBOX1_V_LINE [5:4]: SBOX1_H_LINE [3:2]: SBOX0_V_LINE [1:0]: SBOX0_H_LINE
0x786	R/W	0x00	SBOX0_HL[7:0]
0x787	R/W	0x00	SBOX0_HL[10:8]
0x788	R/W	0x00	SBOX1_HL[7:0]
0x789	R/W	0x00	SBOX1_HL[10:8]
0x78A	R/W	0x00	SBOX2_HL[7:0]
0x78B	R/W	0x00	SBOX2_HL[10:8]
0x78C	R/W	0x00	SBOX3_HL[7:0]
0x78D	R/W	0x00	SBOX3_HL[10:8]
0x78E	R/W	0x00	SBOX0_HR[7:0]
0x78F	R/W	0x00	SBOX0_HR[10:8]
0x790	R/W	0x00	SBOX1_HR[7:0]
0x791	R/W	0x00	SBOX1_HR[10:8]
0x792	R/W	0x00	SBOX2_HR[7:0]
0x793	R/W	0x00	SBOX2_HR[10:8]
0x794	R/W	0x00	SBOX3_HR[7:0]
0x795	R/W	0x00	SBOX3_HR[10:8]
0x796	R/W	0x00	SBOX0_VT[7:0]
0x797	R/W	0x00	SBOX0_VT[10:8]
0x798	R/W	0x00	SBOX1_VT[7:0]
0x799	R/W	0x00	SBOX1_VT[10:8]
0x79A	R/W	0x00	SBOX2_VT[7:0]
0x79B	R/W	0x00	SBOX2_VT[10:8]
0x79C	R/W	0x00	SBOX3_VT[7:0]
0x79D	R/W	0x00	SBOX3_VT[10:8]
0x79E	R/W	0x00	SBOX0_VB[7:0]
0x79F	R/W	0x00	SBOX0_VB[10:8]
0x7A0	R/W	0x00	SBOX1_VB[7:0]
0x7A1	R/W	0x00	SBOX1_VB[10:8]
0x7A2	R/W	0x00	SBOX2_VB[7:0]
0x7A3	R/W	0x00	SBOX2_VB[10:8]
0x7A4	R/W	0x00	SBOX3_VB[7:0]
0x7A5	R/W	0x00	SBOX3_VB[10:8]
0x7A6	R/W	0x00	BBR: Box border R

Address	R/W	Default	Description
0x7A7	R/W	0x00	BBG: Box border G
0x7A8	R/W	0x00	BBB: Box border B
0x7A9	R/W	0x00	BPR: Box plane R
0x7AA	R/W	0x00	BPG: Box plane G
0x7AB	R/W	0x00	BPB: Box plane B
0x7AC	R/W	0x00	MOUSE0_HPOS[7:0]
0x7AD	R/W	0x00	MOUSE0_HPOS[10:8]
0x7AE	R/W	0x00	MOUSE0_VPOS[7:0]
0x7AF	R/W	0x00	MOUSE0_VPOS[10:8]
0x7B0	R/W	0x00	MOUSE1_HPOS[7:0]
0x7B1	R/W	0x00	MOUSE1_HPOS[10:8]
0x7B2	R/W	0x00	MOUSE1_VPOS[7:0]
0x7B3	R/W	0x00	MOUSE1_VPOS[10:8]
0x7B4	R/W	0x00	[6:4]: MOUSE1_CTRL [2:0]: MOUSE0_CTRL
0x7B5	R/W	0x00	BR[7:0]: mouse background R
0x7B6	R/W	0x00	BG[7:0]: mouse background G
0x7B7	R/W	0x00	BB[7:0]: mouse background B
0x7B8	R/W	0x00	FR[7:0]: mouse foreground R
0x7B9	R/W	0x00	FG[7:0]: mouse foreground G
0x7BA	R/W	0x00	FB[7:0]: mouse foreground B
0x7BB	R/W	0x00	MOUSE_WR_LOC[7:0]
0x7BC	WO	0x00	MOUSE_WR_DATA[7:0]
0x7BD	WO	0x00	MOUSE_WR_EN
0x7BE	R/W	0x00	POS_HSCALE[7:0]
0x7BF	R/W	0x10	POS_HSCALE[15:8]
0x7C0	R/W	0x00	POS_VSCALE[7:0]
0x7C1	R/W	0x10	POS_VSCALE[15:8]
0x7C2	R/W	0	[0]: POS_DNS_EN
0x7C3	R/W	0	OSD_BLINK_TIME[1:0]
0x7C4	R/W	0	[6]: OSG_UPSCL_EN1 [5:4]: OSG_BLINK_MODE1 [3:2]: OSG_BLEND_MODE1 [1]: OSG_TRANS_EN1 [0]: OSG_W1_EN
0x7C5	R/W	0	[6]: OSG_UPSCL_EN2 [5:4]: OSG_BLINK_MODE2 [3:2]: OSG_BLEND_MODE2 [1]: OSG_TRANS_EN2 [0]: OSG_W2_EN
0x7C6	R/W	0	[7:4]: OSG_ALPHA2 [3:0]: OSG_ALPHA1
0x7C7	R/W	0	[4]: OSG_FORMAT_RG [3:2]: OSG_FORMAT [1:0]: OSG_BLINK_FRAME
0x7C8	R/W	0	OSG_ALPHA_COLOR1 [7:0]
0x7C9	R/W	0	OSG_ALPHA_COLOR1 [15:8]
0x7CA	R/W	0	OSG_ALPHA_COLOR2 [7:0]
0x7CB	R/W	0	OSG_ALPHA_COLOR2 [15:8]
0x7CC	R/W	0	OSG_ALPHA_COLOR3 [7:0]
0x7CD	R/W	0	OSG_ALPHA_COLOR3 [15:8]
0x7CE	R/W	0	OSG_ALPHA_COLOR4 [7:0]
0x7CF	R/W	0	OSG_ALPHA_COLOR4 [15:8]

Address	R/W	Default	Description
0x7D0	R/W	0	OSG_BLINK_COLOR1 [7:0]
0x7D1	R/W	0	OSG_BLINK_COLOR1 [15:8]
0x7D2	R/W	0	OSG_BLINK_COLOR2 [7:0]
0x7D3	R/W	0	OSG_BLINK_COLOR2 [15:8]
0x7D4	R/W	0	OSG_WM1_VSTART [7:0]
0x7D5	R/W	0	OSG_WM1_VSTART [12:8]
0x7D6	R/W	0	OSG_WM1_HSTART [7:0]
0x7D7	R/W	0	OSG_WM1_HSTART [12:8]
0x7D8	R/W	0	OSG_W1_VSIZE [7:0]
0x7D9	R/W	0	OSG_W1_VSIZE [10:8]
0x7DA	R/W	0	OSG_W1_HSIZE [7:0]
0x7DB	R/W	0	OSG_W1_HSIZE [10:8]
0x7DC	R/W	0	OSG_WS1_VSTART [7:0]
0x7DD	R/W	0	OSG_WS1_VSTART [10:8]
0x7DE	R/W	0	OSG_WS1_HSTART [7:0]
0x7DF	R/W	0	OSG_WS1_HSTART [10:8]
0x7E0	R/W	0	OSG_WM2_VSTART [7:0]
0x7E1	R/W	0	OSG_WM2_VSTART [12:8]
0x7E2	R/W	0	OSG_WM2_HSTART [7:0]
0x7E3	R/W	0	OSG_WM2_HSTART [12:8]
0x7E4	R/W	0	OSG_W2_VSIZE [7:0]
0x7E5	R/W	0	OSG_W2_VSIZE [10:8]
0x7E6	R/W	0	OSG_W2_HSIZE [7:0]
0x7E7	R/W	0	OSG_W2_HSIZE [10:8]
0x7E8	R/W	0	OSG_WS2_VSTART [7:0]
0x7E9	R/W	0	OSG_WS2_VSTART [10:8]
0x7EA	R/W	0	OSG_WS2_HSTART [7:0]
0x7EB	R/W	0	OSG_WS2_HSTART [10:8]
0x7EC	R/W	0x11	[7]: OSG_W2_EN4 [6]: OSG_W2_EN3 [5]: OSG_W2_EN2 [4]: OSG_W2_EN1 [3]: OSG_W1_EN4 [2]: OSG_W1_EN3 [1]: OSG_W1_EN2 [0]: OSG_W1_EN1
0x7ED	R/W	0x00	[3:2]: OSG_W2_SEL [1:0]: OSG_W1_SEL
0x7EE	R/W	0	OSG_VSIZE_DN1 [7:0]
0x7EF	R/W	0	OSG_VSIZE_DN1 [10:8]
0x7F0	R/W	0	OSG_HSIZE_DN1 [7:0]
0x7F1	R/W	0	OSG_HSIZE_DN1 [10:8]
0x7F2	R/W	0	OSG_VSIZE_DN2 [7:0]
0x7F3	R/W	0	OSG_VSIZE_DN2 [10:8]
0x7F4	R/W	0	OSG_HSIZE_DN2 [7:0]
0x7F5	R/W	0	OSG_HSIZE_DN2 [10:8]
0x7F6	R/W	0x40	R_GAIN[7:0]
0x7F7	R/W	0x40	G_GAIN[7:0]
0x7F8	R/W	0x40	B_GAIN[7:0]
0x7F9	R/W	0	R_OFST[7:0]
0x7FA	R/W	0	G_OFST[7:0]
0x7FB	R/W	0	B_OFST[7:0]

Registers

DUAL MONITOR HORIZONTAL TOTAL LOW BYTE REGISTER – 0X700

Bit	R/W	Default	Description
7:0	RW	0	DM_HTT[7:0] Dual monitor horizontal total register. Lower 8 bits of the DM_HTT, it should be set to VESA standard. And it is real value minus 1

DUAL MONITOR HORIZONTAL TOTAL HIGH BYTE REGISTER – 0X701

Bit	R/W	Default	Description
7:5	N/A	-	Reserved
4:0	RW	0	DM_HTT[12:8] Dual monitor horizontal total register, upper 5 bits of the DM_HTT

DUAL MONITOR VERTICAL TOTAL LOW BYTE REGISTER – 0X702

Bit	R/W	Default	Description
7:0	RW	0	DM_VTT [7:0] Dual monitor vertical total register, it should be set to VESA standard. It is real value minus 1.

DUAL MONITOR VERTICAL TOTAL HIGH BYTE REGISTER – 0X703

Bit	R/W	Default	Description
7:3	N/A	-	Reserved
2:0	RW	0	DM_VTT[10:8] Dual monitor vertical total register, it should be set to VESA standard. It is real value minus 1. In interlaced mode, it is set to top field vertical total value minus 1.

DUAL MONITOR HORIZONTAL WIDTH LOW BYTE REGISTER – 0X704

Bit	R/W	Default	Description
7:0	RW	0	DM_HDE[7:0] Dual monitor horizontal active data width. Lower 8 bits of the DM_HDE. This register must be set to read value minus 1.

DUAL MONITOR HORIZONTAL WIDTH HIGH BYTE REGISTER – 0X705

Bit	R/W	Default	Description
7:3	N/A	-	Reserved
2:0	RW	0	DM_HDE [10:8] Dual monitor horizontal active data width. Higher 3 bits of the DM_HDE. This register must be set to read value minus 1.

DUAL MONITOR VERTICAL HEIGHT LOW BYTE REGISTER – 0X706

Bit	R/W	Default	Description
7:0	RW	0	DM_VDE[7:0] Dual monitor vertical display height. Lower 8 bits of the DM_VDE. This register must be set to real value minus 1. In interlaced mode, it is set to height of one field minus 1.

DUAL MONITOR VERTICAL HEIGHT HIGH BYTE REGISTER – 0X707

Bit	R/W	Default	Description
7:5	N/A	-	Reserved
4:0	RW	0	DM_VDE[10:8] Dual monitor vertical display height. Higher 3 bits of the DM_VDE. This register must be set to real value minus 1. In interlaced mode, it is set to height of one field minus 1.

DUAL MONITOR HSYNC FRONT PORCH LOW BYTE REGISTER – 0X708

Bit	R/W	Default	Description
7:0	RW	0	DM_PHSYNC[7:0] Dual monitor hsync front porch register. Lower 8 bits of DM_PHSYNC.

DUAL MONITOR HSYNC FRONT PORCH HIGH BYTE REGISTER – 0X709

Bit	R/W	Default	Description
7:1	N/A	-	Reserved
0	RW	0	DM_PHSYNC [8] Dual monitor hsync front porch register. MSB of DM_PHSYNC.

DUAL MONITOR VSYNC FRONT PORCH REGISTER – 0X70A

Bit	R/W	Default	Description
7:0	RW	0	DM_PVSYNC[7:0] Dual monitor vsync front porch register.

DUAL MONITOR HSYNC WIDTH REGISTER – 0X70B

Bit	R/W	Default	Description
7:0	RW	0	DM_HSPW [7:0] Dual monitor hsync width register. It uses one pixel unit.

DUAL MONITOR VSYNC WIDTH REGISTER – 0X70C

Bit	R/W	Default	Description
7:0	RW	0	DM_VSPW [7:0] Dual monitor vsync width register. It uses one line unit.

DUAL MONITOR CONTROL REGISTER – 0X70D

Bit	R/W	Default	Description
7	RW	0	MDBOX_EN: Dual monitor motion box control 0: off 1: on
6	RW	0	VTT_INV Vertical total exchange between top field and bottom field. In interlace mode, top field has VTT+1 lines, even field has VTT+2 lines. If this bit set to high, top field has VTT+2 lines, and even field has VTT+1 lines. This bit is not used in normal case. It is only used in debug mode.
5	RW	0	DM_INT_CBAR Dual monitor internal color bar test on in TV encoder
4	RW	0	EVEN_REPEAT 0: repeat odd or even when needed 1: repeat even field only
3:0	RW	0	VSYNC_DLY The time between hsync and vsync edge.

DUAL MONITOR TARGET WIDTH FOR DOWN SCALER LOW BYTE REGISTER – 0X70E

Bit	R/W	Default	Description
7:0	RW	0	TAR_W[7:0] Dual monitor down scaler target image width. One pixel unit.

DUAL MONITOR TARGET WIDTH FOR DOWN SCALER HIGH BYTE REGISTER – 0X70F

Bit	R/W	Default	Description
7:3	N/A	-	Reserved
2:0	RW	0	TAR_W[10:8] Dual monitor down scaler target image width. One pixel unit.

DUAL MONITOR TARGET HEIGHT FOR DOWN SCALER LOW BYTE REGISTER – 0X710

Bit	R/W	Default	Description
7:0	RW	0	TAR_H[7:0] Dual monitor down scaler target image height. One line unit.

DUAL MONITOR TARGET HEIGHT FOR DOWN SCALER HIGH BYTE REGISTER – 0X711

Bit	R/W	Default	Description
7:3	N/A	-	Reserved
2:0	RW	0	TAR_H[10:8] Dual monitor down scaler target image height. One line unit.

DUAL MONITOR MODE REGISTER – 0X712

Bit	R/W	Default	Description
7	-		Reserved
6	RW	0	IN16_MODE: 16 bits input on/off control for down-scaler
5	RW	0	DM_YC_SWAP: Control luma and chroma position for BT1120 output
4	RW	0	DM_MAIN: Dual monitor video use main display RGB output
3	RW	0	DM_ENA: Dual Monitor Enable
2	RW	0	DM_LCD: Dual monitor is LCD mode register 1: When the dual monitor is connected to LCD VGA mode 0: When the dual monitor is connected to Analog TV
1	RW	0	DM_VSPOL: Dual monitor vertical sync polarity register 0: negative 1: positive
0	RW	0	DM_HSPOL: Dual monitor horizontal sync polarity register 0: negative 1: positive

DUAL MONITOR HORIZONTAL START LOW BYTE REGISTER – 0X713

Bit	R/W	Default	Description
7:0	RW	00	DM_HSTART[7:0] Dual monitor DRAM horizontal start register. It is four pixels unit.

DUAL MONITOR VERTICAL START LOW BYTE REGISTER – 0X714

Bit	R/W	Default	Description
7:0	RW	00	DM_VSTART [7:0] Dual monitor DRAM vertical start register. It is one line unit.

DUAL MONITOR HSTART AND VSTART HIGH BYTE REGISTER – 0X715

Bit	R/W	Default	Description
5:4	RW	0	DM_HSTART [9:8] Dual monitor DRAM horizontal start register. It is four pixels unit.
3:0	RW	0	DM_VSTART[11:8] Dual monitor DRAM vertical start register. It is one line unit.

DUAL MONITOR DOWN SCALER SOURCE WIDTH LOW BYTE REGISTER – 0X716

Bit	R/W	Default	Description
7:0	RW	00	SRC_W [7:0] Dual monitor down scaler source image width, 1 pixel unit.

DUAL MONITOR DOWN SCALER SOURCE WIDTH HIGH BYTE REGISTER – 0X717

Bit	R/W	Default	Description
5:3	RW	0	DM_HSTART [9:8] Dual monitor DRAM horizontal start register. It is four pixels unit.
2:0	RW	0	SRC_W[10:8] Dual monitor down scaler source image width, 1 pixel unit.

DUAL MONITOR DOWN SCALER SOURCE HEIGHT LOW BYTE REGISTER – 0X718

Bit	R/W	Default	Description
7:0	RW	0	SRC_H[7:0] Dual monitor down scaler source image height, 1 line unit.

DUAL MONITOR DOWN SCALER SOURCE HEIGHT HIGH BYTE REGISTER – 0X719

Bit	R/W	Default	Description
5:3	RW	0	DM_HSTART [9:8] Dual monitor DRAM horizontal start register. It is four pixels unit.
2:0	RW	0	SRC_H[10:8] Dual monitor down scaler source image height, 1 line unit.

DUAL MONITOR TV ENCODER CONTROL REGISTER 1 – 0X71A

Bit	R/W	Default	Description
7:6	RW	0	TVENC_FSC_MODE Dual Monitor TV FSCSEL. This register determines the TV modulation frequency standard select. 00: NTSC/M 01: PAL/B, D, G, H, I 10: PAL/M 11: PAL/N
5	RW	0	TVENC_SAT_LMT Dual Monitor TV video saturation limit. Control the data range of the ITU-R BT 656 output 0: Not limit 1: Data range is limited to 1 – 254 range
4:1	-	-	Reserved
0	RW	0	TVENC_PALNT Dual Monitor TV PAL or NTSC select. This register determines the CVBS output Standard. 0: NSTC mode 1: PAL mode.

DUAL MONITOR TV ENCODER CONTROL REGISTER 2 – 0X71B

Bit	R/W	Default	Description
7	RW	0	TVENC_VSPOL: Dual Monitor TVENC Vertical sync polarity 0: Active Low 1: Active High
6	RW	0	TVENC_HSPOL: Dual Monitor TV Encoder Horizontal Sync Polarity 0: Active Low 1: Active High
5	RW	0	TVENC_VSDEC: Dual monitor TV Encoder vsync detect signal 0: vsync signal 1: field signal
4	RW	0	TVENC_PED: Dual Monitor TV encoder Pedestal Enable. Enable Pedestal for video output. 0: 0 IRE for pedestal 1: 7.5 IRE pedestal level
3	RW	0	TVENC_PDRST: Dual Monitor TV Encoder Pedestal Reset. Subcarrier Phase Alternation reset every 8 field in PAL system 0: Constant relationship, reset every 8 field 1: Free running
2	RW	0	TVENC_PHALT: Dual Monitor TV Encoder Phase Alternation. 0: Disable phase alternation for line by line 1: Enable phase alternation for line by line
1	RW	0	TVENC_F_INV: Dual Monitor TV Encoder Field Output Invert. This register bit inverts the field output level if set.
0	RW	0	INTERLACE: Dual Monitor Interlaced mode enable. 0: progressive 1: interlaced

DUAL MONITOR TV ENCODER CONTROL REGISTER 3 – 0X71C

Bit	R/W	Default	Description
7:6	N/A		Reserved
6:5	RW	0	TVENC_YC_OS[1:0]: Dual Monitor TV Encoder Active Pixel Offset delay 00: No Active offset 01: Active pixel offset for 1/4 pixel unit 10: Active pixel offset for 1/2 pixel unit 11: Active pixel offset for 3/4 pixel unit
4	RW	1	TVENC_OSENC[2] 0: one more line delay on odd field 1: odd field and even field same delay
3:2	RW	00	TVENC_OSENC[1:0]: Dual Monitor TV Encoder Field Offset for the first video line 00: No delay for odd field and even field 01: No delay for even field, delay one line for odd field 10: Delay one line for even field, no delay for odd field 11: Delay two lines for even field, no delay for odd field

Bit	R/W	Default	Description
1	RW	0	TVENC_FLDENCP: Dual Monitor TV Encoder Field Polarity. This Register control the field polarity. 0: Even field is high 1: Odd field is high
0	-	-	Reserved

DUAL MONITOR TV ENCODER PIXEL DELAY LOW BYTE REGISTER – 0X71D

Bit	R/W	Default	Description
7:0	RW	0	TVENC_HSENC[7:0]: Dual Monitor TV Encoder Active pixel delay. Lower 8 bit of the pixel delay from active video by ½ pixel per step

DUAL MONITOR TV ENCODER PIXEL DELAY HIGH BYTE REGISTER – 0X71E

Bit	R/W	Default	Description
1:0	RW	0	TVENC_HSENC[9:8]: Dual Monitor TV Encoder Active pixel delay. Upper 2 bit of the pixel delay from active video by ½ pixel per step

DUAL MONITOR TV ENCODER LINE DELAY REGISTER – 0X71F

Bit	R/W	Default	Description
5:0	RW	0	TVENC_VSENC[5:0]: Dual Monitor TV Encoder Active line delay, 6 bit of the line delay from active video by line per step

DUAL MONITOR TV ENCODER LINE OFFSET REGISTER – 0X720

Bit	R/W	Default	Description
4:0	RW	0	TVENC_LINE_OS[4:0]: Dual Monitor TV Encode line Offset, 5 bit of the line offset from active video

DUAL MONITOR TV ENCODER PIXEL OFFSET REGISTER – 0X721

Bit	R/W	Default	Description
5:0	RW	0	TVENC_PIXEL_OS[5:0]: Dual Monitor TV Encode Pixel Offset, 6 bit of the Pixel Offset from active video

DUAL MONITOR TV ENCODER CONTROL REGISTER 4 – 0X722

Bit	R/W	Default	Description
6	RW	0	DM_TVENC_C_OFF_D: Dual Monitor TV Encoder Color Offset
5:4	RW	0	DM_TVENC_CBW_D: Dual Monitor TV Encoder Chrominance Bandwidth Control
3:2	RW	0	DM_TVENC_YBW_D: Dual Monitor TV Encoder Luminance Bandwidth Control
1:0	RW	0	DM_TVENC_FLD_OS: Dual Monitor TV Encoder Active Field offset.

DUAL MONITOR TV ENCODER CONTROL REGISTER 5 – 0X723

Bit	R/W	Default	Description
7	RW	0	DM_TVENC_TST_FSC_FREE: Dual monitor TV Encoder Sub-Carrier is set to free run
6	RW	0	DM_TVENC_T_CCIR_TIM: Dual monitor TV Encoder CCIR Timing
5	RW	0	DM_TVENC_T_656_STD: Dual monitor TV Encoder 656 Standard
4:0	RW	0	DM_TVENC_VIS_LINE_OS: Dual monitor TV Encoder line offset

DUAL MONITOR CONTROL REGISTER – 0X724

Bit	R/W	Default	Description
4	R/W	0	OSD_CH_EN_SEL: Simple OSD channel enable select. 0: use rgb_interface channel enable 1: use another register set, [0x728] to [0x72B]
3	R/W	0	NOVID_SWITCH_EN: In normal case, this bit set to 0. No video color will show up. If this bit set to 1, SDRAM data will show up.
2	R/W	0	BND_CH_EN_SEL: Boundary channel enable select. 0: use rgb_interface channel enable 1: use another register set, [0x728] to [0x72B]
1	RW	0	NO_DNS: Turn off down scaler. When this bit set to 1, dm_fclk must be bigger than dm_vclk 1: bypass down scaler 0: use down scaler.
0	RW	0	VGA_DIS: Disable dual monitor VGA output. Hsync, Vsync and Data will be low when this bit set to high.

DUAL MONITOR DAC POWER DOWN REGISTER – 0X725

Bit	R/W	Default	Description
2	RW	0	DM_PD_R: Power down R DAC
1	RW	0	DM_PD_G: Power down G DAC
0	RW	0	DM_PD_B: Power down B DAC

DUAL MONITOR MOUSE UPDATE ENABLE REGISTER – 0X726

Bit	R/W	Default	Description
0	RW	0	MOUSE_UPDATE_EN Mouse data update from SDRAM to local SRAM enable. Hardware will automatically clear this bit when finish operation.

DUAL MONITOR DOWN SCALER HORIZONTAL BLANK REGISTER – 0X727

Bit	R/W	Default	Description
7:0	RW	0x20	DNS_HBLANK: Down scaler hblank time.

DUAL MONITOR BOUNDARY CHANNEL ENABLE REGISTER 1 – 0X728

Bit	R/W	Default	Description
7:0	RW	0	BND_CH_EN[7:0]: Boundary channel enable. This register is only used when BND_CH_EN_SEL is high. This is only used when user want to show boundary when channel is not enable.

DUAL MONITOR BOUNDARY CHANNEL ENABLE REGISTER 2 – 0X729

Bit	R/W	Default	Description
7:0	RW	0	BND_CH_EN[15:8]: Boundary channel enable. This register is only used when BND_CH_EN_SEL is high. This is only used when user want to show boundary when channel is not enable.

DUAL MONITOR BOUNDARY CHANNEL ENABLE REGISTER 3 – 0X72A

Bit	R/W	Default	Description
7:0	RW	0	BND_CH_EN[23:16]: Boundary channel enable. This register is only used when BND_CH_EN_SEL is high. This is only used when user want to show boundary when channel is not enable.

DUAL MONITOR BOUNDARY CHANNEL ENABLE REGISTER 4 – 0X72B

Bit	R/W	Default	Description
7:0	RW	0	BND_CH_EN[31:24]: Boundary channel enable. This register is only used when BND_CH_EN_SEL is high. This is only used when user want to show boundary when channel is not enable.

DUAL MONITOR RED COLOR FOR NO VIDEO CHANNEL – 0X72C

Bit	R/W	Default	Description
7:0	RW	0	NOVID_R: This color will show up when the channel boundary is enable, but channel has no video.

DUAL MONITOR GREEN COLOR FOR NO VIDEO CHANNEL – 0X72D

Bit	R/W	Default	Description
7:0	RW	0	NOVID_G: This color will show up when the channel boundary is enable, but channel has no video.

DUAL MONITOR BLUE COLOR FOR NO VIDEO CHANNEL – 0X72E

Bit	R/W	Default	Description
7:0	RW	0xFF	NOVID_B: This color will show up when the channel boundary is enable, but channel has no video.

DUAL MONITOR MOUSE INDEX REGISTER – 0X72F

Bit	R/W	Default	Description
4	RW	0	MOUSE_BUF: There are two mouse buffer in local SRAM. This bit select which buffer will be updated. 0: first mouse buffer 1: second mouse buffer
3:0	RW	0	MOUSE_INDEX: This register set which mouse shape will be loaded from SDRAM. Up to 16 mouse shapes can be saved in SDRAM. If user wants more than 16 mouse shape, user can set different mouse base address.

DUAL MONITOR SIMPLE OSD REGISTER – 0X730 TO 0X75E

Please refer to simple OSD chapter.

DUAL MONITOR HORIZONTAL DISPLAY ENABLE CONTROL REGISTER – 0X75F

Bit	R/W	Default	Description
1	RW	1	MOUSE_REG_UPDATE: When update mouse position register, set this bit to 0. After finish, set this bit to 1.
0	RW	1	OSG_REG_UPDATE: When update OSG related register, set this bit to 0. After finish, set this bit to 0

DUAL MONITOR BACKGROUND RED COLOR REGISTER – 0X760

Bit	R/W	Default	Description
7:0	RW	0	BAR: Dual Monitor Background Red Color

DUAL MONITOR BACKGROUND GREEN COLOR REGISTER – 0X761

Bit	R/W	Default	Description
7:0	RW	0	BAG: Dual Monitor Background Green Color

DUAL MONITOR BACKGROUND BLUE COLOR REGISTER – 0X762

Bit	R/W	Default	Description
7:0	RW	0	BAB: Dual Monitor Background Blue Color

DUAL MONITOR CONTROL REGISTER – 0X763

Bit	R/W	Default	Description
7	RW	0	SWITCH_EN: This bit is used for debug mode. When this bit set to 1, background will disabled, data in SDRAM will show up.
6	RW	0	COLBAR_EN: Color bar enable in background layer
5	RW	0	GAIN_EN: RGB digital gain enable
4	RW	0	BND_EN: Dual Monitor Border Width Enable
3:0	RW	0	BND_WIDTH: Dual Monitor Border Width

DUAL MONITOR BOUNDARY RED COLOR REGISTER– 0X764

Bit	R/W	Default	Description
7:0	RW	0	BND_R: Dual Monitor Border Red Color

DUAL MONITOR BOUNDARY GREEN COLOR REGISTER– 0X765

Bit	R/W	Default	Description
7:0	RW	0	BND_G: Dual Monitor Border Green Color

DUAL MONITOR BOUNDARY BLUE COLOR REGISTER – 0X766

Bit	R/W	Default	Description
7:0	RW	0	BND_B: Dual Monitor Border Blue Color

DUAL MONITOR VERTICAL TOTAL WINDOW REGISTER – 0X767

Bit	R/W	Default	Description
7:0	R/W	0xFF	VTT_WIN[7:0]: Vertical Total can be changed according to input video frame rate. If difference is more than this number, VTT will not be adjusted. Unit is 1 line.

DUAL MONITOR VERTICAL TOTAL ADJUST MODE REGISTER – 0X768

Bit	R/W	Default	Description
2	R/W	0x00	VTT_ADJUST: It is used for manual mode. After set this bit, VTT will be changed according to current input video frame rate.
1	R/W	0	VTT_ADJUST_MODE 1: auto mode, adjust VTT each frame 0: manual mode, adjust VTT after set VTT_ADJUST
0	R/W	0	VTT_ADJUST_EN: Enable VTT adjustment. If set to 0, use register setting. If set to 1, use input video frame rate.

DUAL MONITOR VERTICAL TOTAL FROM INPUT VIDEO LOW BYTE REGISTER – 0X769

Bit	R/W	Default	Description
7:0	RO	-	NEW_VTT_RGBW[7:0]: It is calculated from input video. The number is for two fields.

DUAL MONITOR VERTICAL TOTAL FROM INPUT VIDEO HIGH BYTE REGISTER – 0X76A

Bit	R/W	Default	Description
3:0	RO	-	NEW_VTT_RGBW[11:8]: It is calculated from input video. The number is for two fields.

DUAL MONITOR VERTICAL TOTAL AFTER ADJUSTMENT BYTE REGISTER – 0X76B

Bit	R/W	Default	Description
7:0	RO	-	NEW_VTTI[7:0]: It is new VTT which is used in output timing. The number is for one field.

DUAL MONITOR VERTICAL TOTAL AFTER ADJUSTMENT HIGH REGISTER – 0X76C

Bit	R/W	Default	Description
2:0	RO	-	NEW_VTT[10:8]: It is new VTT which is used in output timing. The number is for one field.

DUAL MONITOR SINGLE BOX REGISTER – 0X76D TO 0X7AB

Dual monitor has four single box. Register descriptions are same as main display. Please refer to LCD chapter.

DUAL MONITOR MOUSE REGISTER – 0X7AC TO 0X7BD

Dual monitor has two mouse layer. Register descriptions are same as in main display. Please refer to LCD chapter.

HORIZONTAL DOWN SCALER FACTOR LOW BYTE REGISTER – 0X7BE

Bit	R/W	Default	Description
7:0	R/W	0x00	POS_HSCALE[7:0] Channel position information down scale factor. 0x1000 means no down scale. Value smaller than 0x1000 means down scale. If image is down scaled, this register must be set correctly.

HORIZONTAL DOWN SCALE FACTOR HIGH BYTE REGISTER – 0X7BF

Bit	R/W	Default	Description
7:0	R/W	0x10	POS_HSCALE[15:8] Channel position information down scale factor. 0x1000 means no down scale. Value smaller than 0x1000 means down scale. If image is down scaled, this register must be set correctly.

VERTICAL DOWN SCALE FACTOR LOW BYTE REGISTER – 0X7C0

Bit	R/W	Default	Description
7:0	R/W	0x00	POS_VSCALE[7:0] Channel position information down scale factor. 0x1000 means no down scale. Value smaller than 0x1000 means down scale. If image is down scaled, this register must be set correctly.

VERTICAL DOWN SCALER FACTOR HIGH BYTE REGISTER – 0X7C1

Bit	R/W	Default	Description
7:0	R/W	0x10	POS_VSCALE[15:8] Channel position information down scale factor. 0x1000 means no down scale. Value smaller than 0x1000 means down scale. If image is down scaled, this register must be set correctly.

POSITION DOWN SCALER ENABLE CONTROL REGISTER – 0X7C2

Bit	R/W	Default	Description
7:1	R	0	Reserved
0	R/W	0	POS_DNS_EN: Use down scaled position information if this bit set to high.

OSD BLINK RATE REGISTER – 0X7C3

Bit	R/W	Default	Description
1:0	R/W	0x00	OSD_BLINK_TIME: OSD blinking frequency control 00: blinking on each 32 frames 01: blinking on each 16 frames 10: blinking on each 8 frames 11: blinking on each 4 frames

DUAL MONITOR OSG REGISTER – 0X7C4 TO 0X7F5

Dual monitor has two layer OSG. Each layer has four sub-windows. Register descriptions are same as main display. Please refer to OSG chapter.

DUAL MONITOR DIGITAL R GAIN REGISTER – 0X7F6

Bit	R/W	Default	Description
7:0	R/W	0x40	R_GAIN: R digital gain. 0x40 is no gain. More than 0x40 means gain more than 1.

DUAL MONITOR DIGITAL G GAIN REGISTER – 0X7F7

Bit	R/W	Default	Description
7:0	R/W	0x40	G_GAIN: G digital gain. 0x40 is no gain. More than 0x40 means gain more than 1.

DUAL MONITOR DIGITAL B GAIN REGISTER – 0X7F8

Bit	R/W	Default	Description
7:0	R/W	0x40	B_GAIN: B digital gain. 0x40 is no gain. More than 0x40 means gain more than 1.

DUAL MONITOR R OFFSET REGISTER – 0X7F9

Bit	R/W	Default	Description
7:0	R/W	0x00	R_OFST[7:0] R offset. $R_{out} = R_{in} * R_GAIN + R_OFST$. This value is 2's complement value. R_OFST can be negative data.

DUAL MONITOR G OFFSET REGISTER – 0X7FA

Bit	R/W	Default	Description
7:0	R/W	0x00	G_OFST[7:0] G offset. $R_{out} = R_{in} * R_GAIN + R_OFST$. This value is 2's complement value. R_OFST can be negative data.

DUAL MONITOR B OFFSET REGISTER - 0X7FB

Bit	R/W	Default	Description
7:0	R/W	0x00	B_OFST[7:0] B offset. $R_{out} = R_{in} * R_GAIN + R_OFST$. This value is 2's complement value. R_OFST can be negative data.

DMA Controller (DMAC)

Overview

The TW2880's direct memory access controller (DMAC) is a second-generation platform block capable of performing complex data movements through 2 programmable channels, with minimal intervention from the host processor. The hardware micro-architecture includes a DMA engine that performs source and destination address calculations, and the actual data movement operations, along with an DRAM-based memory containing the transfer control descriptors (TCD) for the channels. DMAC can be programmed to move data between the host processor and TW2880's off-chip memory or between two locations in the off-chip DRAM independently with the minimum help from CPU. Two independent DMA channels are supported.

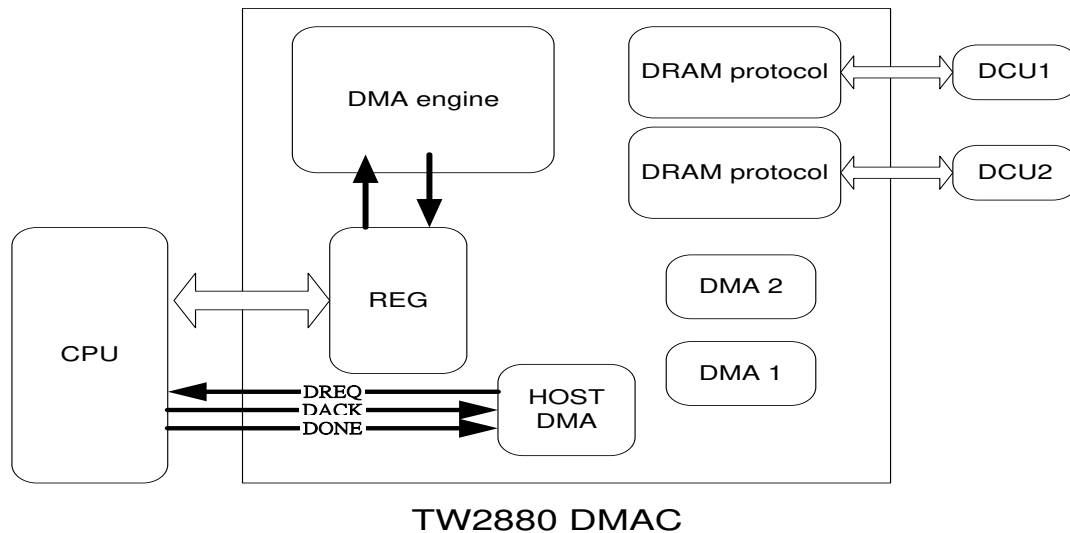

Features

DMA subsystem features are summarized as follow:

DMA Engine

- 2 independent channels that can move data between
 - Host processor and TW2880's LCD or recording memory
 - Two memory areas in TW2880's LCD or recording memory
- Programmable source / destination starting address

Theory of Operation

DMA ENGINE

TW2880 DMA operations include:

- SDRAM to SDRAM block moves
- Host to SDRAM moves

A DMA operation begins when software enables a DMA channel, after setting the source and destination starting addresses, transfer count, bus transaction size. The DMA Engine moves the data block, and the DMA operation ends when the number of bytes specified by the transfer count has been reached. A DMA operation may also end early by programmer. When a DMA operation ends, an interrupt is sent to the host processor. Status register in each channel can be used to identify the event that caused the interrupt: a normal operation end or any one of several types of error ends.

The exact transfer count of each DMA operation is controlled by Transfer Size Count Register(0x242 ~0x243, 0x246 ~ 0x247). The data moving sequence is performed as a series of DRAM transactions. The burst memory transaction size is controlled by DCU and is not changeable from DMA.

The source and destination starting addresses are set by firmware programmers. These addresses are incremented by the DMA. All addresses are physical addresses. The DMA control information can be set by direct CPU writes to DMA registers or alternatively, this DMA control information can be read from DMA descriptors stored in the off-screen memory.

DRAM INTERFACE

DMA is a low priority DCU client. When transferring data to/from DRAM, the normal handshake is followed. If both channels are activated, a arbiter inside the DMA will do the arbitration to share the DRAM bandwidth. Also programmer needs to make the addresses are correct to prevent overwriting. During the transactions, if time out situation occurs, both DMA channel will report the status and let host CPU decide if a software reset is needed.

EXTERNAL DMA DREQ/DACK PROTOCOL

There are two types of external DMA request/acknowledge protocols (Single service Demand, Single service Handshake). Each type defines how the signals like DMA request and acknowledge are related to these protocols.

Basic DMA Timing

The DMA service means performing paired Reads and Writes cycles during DMA operation, which can make one DMA operation. Under figure shows the basic Timing in the DMA operation.

- The setup time and the delay time of DREQ and DACK are the same in all the modes.
 - If the completion of DREQ meets its setup time, it is synchronized twice and then DACK is asserted.
 - After assertion of DACK, DMA requests the bus and if it gets the bus it performs its operations.
- DACK is negated when DMA operation is completed.

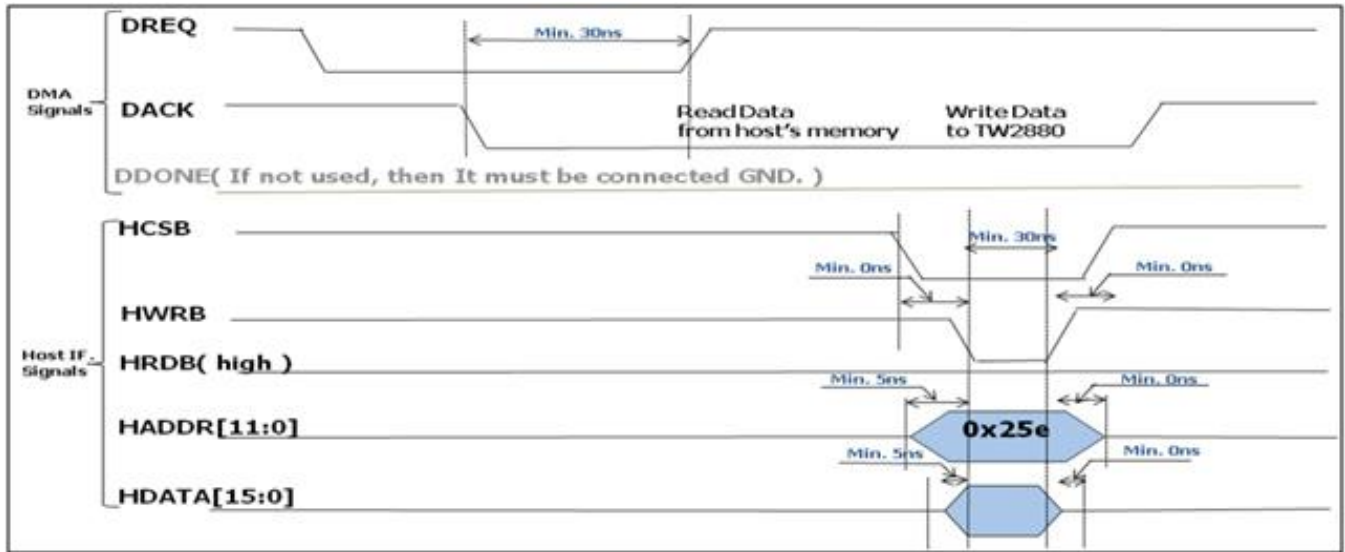

BASIC DMA TIMING DIAGRAM

Demand and Handshake modes are related to the protocol between DREQ and DACK. Figure shows the differences between the two modes.

At the end of one transfer (Single/Burst transfer), DMA checks the state of double-synched DREQ.

Demand Mode

- If DREQ remains asserted, the next transfer starts immediately. Otherwise it waits for DREQ to

be asserted.

Handshake Mode

- If DREQ is negated, DMA negates DACK. Otherwise it waits until DREQ is de-asserted.

Caution: DREQ has to be asserted (low) only after the negation (high) of DACK.

(described in a processor point of view)

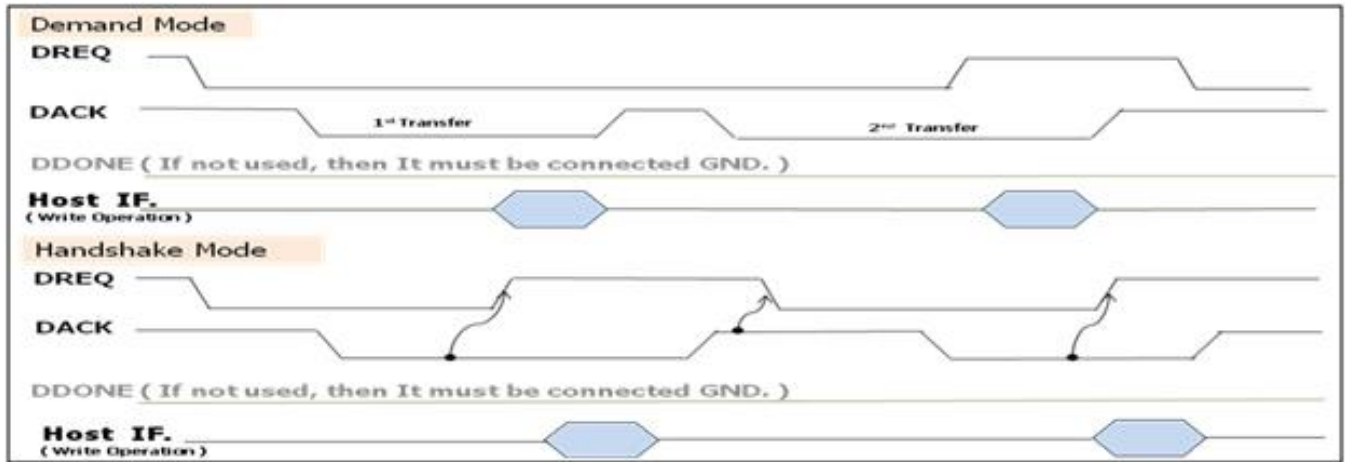

DEMAND/HANDSHAKE MODE COMPARISON

Transfer Size

- There are two different transfer sizes; Single and Burst 4.

- DMA holds the bus firmly during the transfer of the chunk of data. Thus, other bus masters cannot get the bus.

Burst 4 Transfer Size

Four sequential Reads and Writes respectively are performed In the Burst 4 Transfer.

* Note: Single Transfer size: One read and one write are performed.

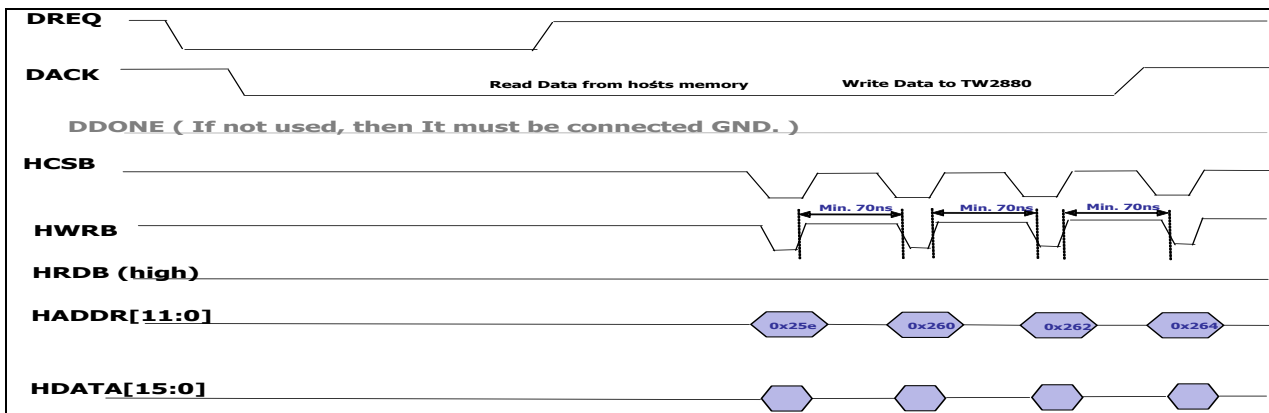

BURST 4 TRANSFER SIZE

EXAMPLES

Single service in Demand Mode with Single Transfer Size

The assertion of DREQ is need for every Single transfer (Single service mode). The operation continues while the DREQ is asserted (Demand mode), and one pair of Read and Write (Single transfer size) is performed.

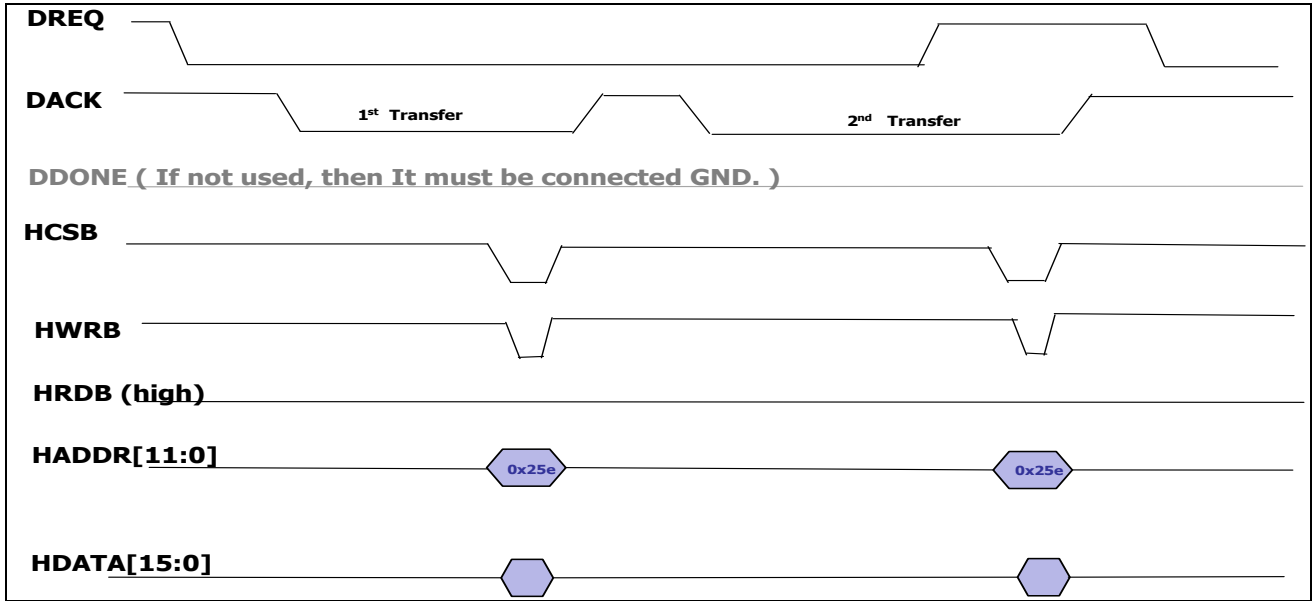

SINGLE SERVICE IN DEMAND MODE WITH SINGLE TRANSFER SIZE

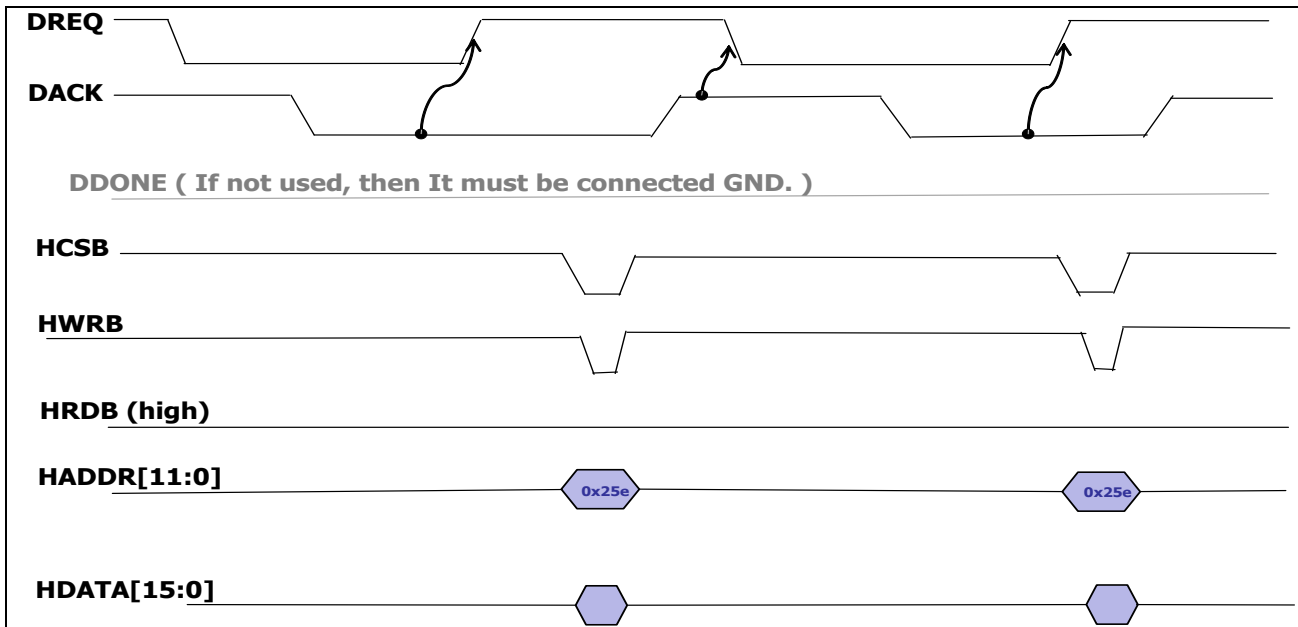

SINGLE SERVICE IN HANDSHAKE MODE WITH SINGLE TRANSFER SIZE

Example 1) DRAM Copy to same bank

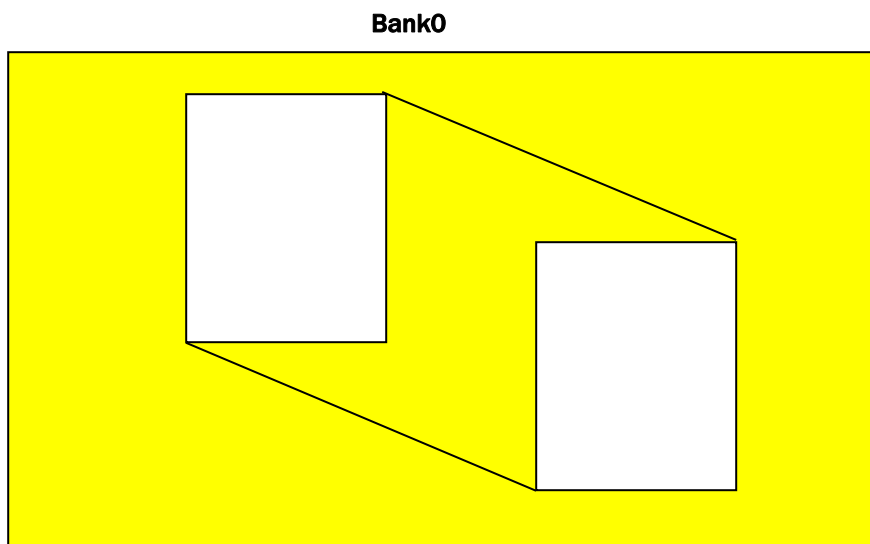

Example 2) DRAM Copy to another bank

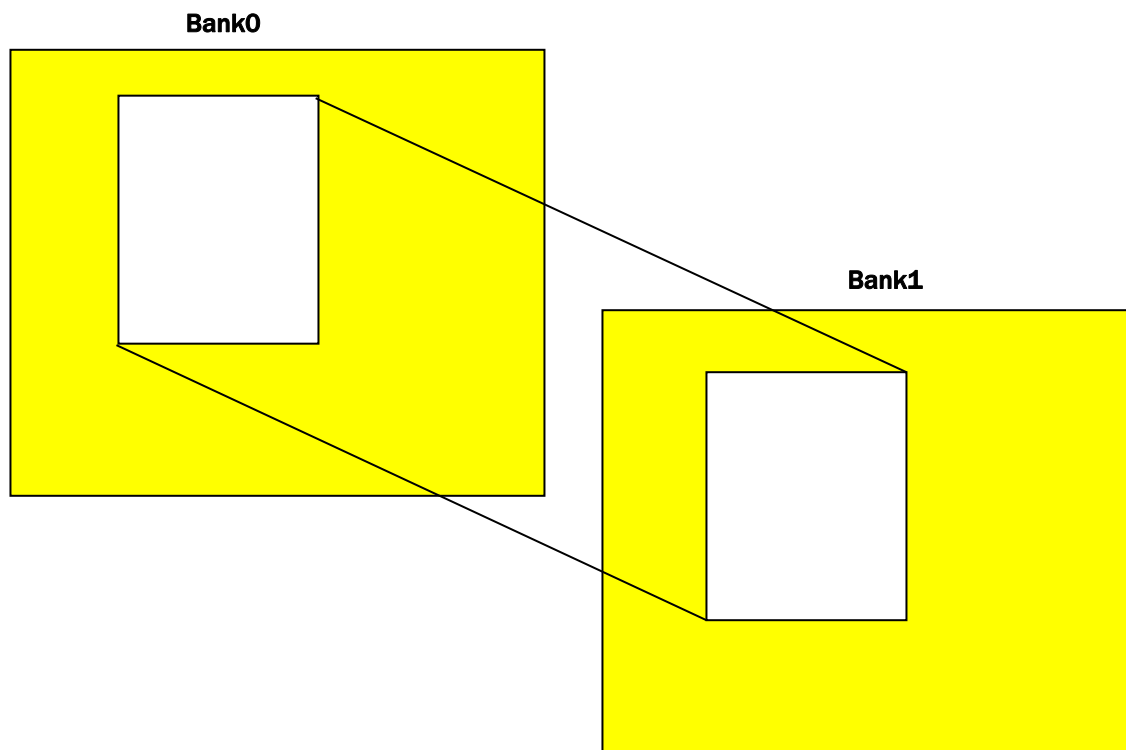

Register Table

Address	R/W	Default	Description
0x230	R/W	0	Display DRAM Source Vertical Position LSB Register
0x231	R/W	0	Display DRAM Source Vertical Position MSB Register
0x232	R/W	0	Display DRAM Destination Vertical Position LSB Register
0x233	R/W	0	Display DRAM Destination Vertical Position MSB Register
0x234	R/W	0	Display DRAM Vertical Transfer Size LSB Register
0x235	R/W	0	Display DRAM Vertical Transfer Size MSB Register
0x236	R/W	0	Display DRAM Source Horizontal Position LSB Register
0x237	R/W	0	Display DRAM Source Horizontal Position MSB Register
0x238	R/W	0	Display DRAM Destination Hori. Position LSB Register
0x239	R/W	0	Display DRAM Destination Hori. Position MSB Register
0x23A	R/W	0	Display DRAM Horizontal Transfer Size LSB Register
0x23B	R/W	0	Display DRAM Horizontal Transfer Size MSB Register
0x23C	R/W	0	Display DRAM DMA Enable Register
0x240	R/W	0	Host DMA Destination Vertical Position LSB
0x241	R/W	0	Host DMA Destination Vertical Position MSB
0x242	R/W	0	Host DMA Vertical Transfer Size LSB Register
0x243	R/W	0	Host DMA Vertical Transfer Size MSB Register
0x244	R/W	0	Host DMA Destination Horizontal Position LSB Register
0x245	R/W	0	Host DMA Destination Horizontal Position MSB Register
0x246	R/W	0	Host DMA Horizontal Transfer Size Register LSB
0x247	R/W	0	Host DMA Control Register
0x248	R/W	0	Host DMA Enable Register
0x249	R/W	0	Host DMA Transfer Mode Control Register
0x24A	R/W	0	Host DMA Status Register
0x24B	R/W	0	OSG Total Transfer Size LSB Register 1
0x24C	R/W	0	OSG Total Transfer Size LSB Register 2
0x24D	R/W	0	OSG Total Transfer Size LSB Register 3
0x24E	R/W	0	OSG Total Transfer Size MSB Register
0x25E-0x264	R/W	0	OSG Write Data
0x268	R/W	0	Host DMA Display Pitch LSB Register
0x269	R/W	0	Host DMA Display Pitch MSB Register
0x26A	R/W	0	Host DMA Start Address LSB Register 1
0x26B	R/W	0	Host DMA Start Address LSB Register 2
0x26C	R/W	0	Host DMA Start Address MSB Register
0x250	R/W	0	Record DRAM Source Vertical Position LSB Register
0x251	R/W	0	Record DRAM Source Vertical Position MSB Register
0x252	R/W	0	Record DRAM Destination Vertical Position LSB Register
0x253	R/W	0	Record DRAM Destination Vertical Position MSB Register
0x254	R/W	0	Record DRAM Vertical Transfer Size LSB Register
0x255	R/W	0	Record DRAM Vertical Transfer Size MSB Register
0x256	R/W	0	Record DRAM Source Horizontal Position LSB Register
0x257	R/W	0	Record DRAM Source Horizontal Position MSB Register
0x258	R/W	0	Record DRAM Destination Hori. Position LSB Register
0x259	R/W	0	Record DRAM Destination Hori. Position MSB Register
0x25A	R/W	0	Record DRAM Horizontal Transfer Size LSB Register
0x25B	R/W	0	Record DRAM Horizontal Transfer Size MSB Register

Address	R/W	Default	Description
0x25C	R/W	0	Record DRAM DMA Enable Register

Register Definition

DISPLAY DRAM SOURCE VERTICAL POSITION LSB REGISTER – 0X230

Bit	R/W	Default	Description
7:0	W	0	Source vertical position[7:0] (a line)

DISPLAY DRAM SOURCE VERTICAL POSITION MSB REGISTER – 0X231

Bit	R/W	Default	Description
7:6	W	0	Reserved
5:4	W	0	Source bank
3:0	W	0	Source vertical position[11:8]

DISPLAY DRAM DESTINATION VERTICAL POSITION LSB REGISTER – 0X232

Bit	R/W	Default	Description
7:0	W	0	Destination vertical position[7:0] (a line)

DISPLAY DRAM DESTINATION VERTICAL POSITION MSB REGISTER – 0X233

Bit	R/W	Default	Description
7:6	W	0	Reserved
5:4	W	0	Destination bank
3:0	W	0	Destination vertical position[11:8]

DISPLAY DRAM VERTICAL TRANSFER SIZE LSB REGISTER – 0X234

Bit	R/W	Default	Description
7:0	W	0	Vertical transfer size[7:0] (a line)

DISPLAY DRAM VERTICAL TRANSFER SIZE MSB REGISTER – 0X235

Bit	R/W	Default	Description
7:3	W	0	Reserved
2:0	W	0	Vertical transfer size [10:8]

DISPLAY DRAM SOURCE HORIZONTAL POSITION LSB REGISTER – 0X236

Bit	R/W	Default	Description
7:0	W	0	Source horizontal position[7:0] (4 pixels)

DISPLAY DRAM SOURCE HORIZONTAL POSITION MSB REGISTER – 0X237

Bit	R/W	Default	Description
7:2	W	0	Reserved
1:0	W	0	Source vertical position[9:8]

DISPLAY DRAM DESTINATION HORIZONTAL POSITION LSB REGISTER – 0X238

Bit	R/W	Default	Description
7:0	W	0	Destination horizontal position[7:0] (4 pixels)

DISPLAY DRAM DESTINATION HORIZONTAL POSITION MSB REGISTER – 0X239

Bit	R/W	Default	Description
7:2	W	0	Reserved
1:0	W	0	Destination horizontal position[9:8]

DISPLAY DRAM HORIZONTAL TRANSFER SIZE LSB REGISTER – 0X23A

Bit	R/W	Default	Description
7:0	W	0	Horizontal transfer size[7:0] (4 pixels)

DISPLAY DRAM HORIZONTAL TRANSFER SIZE MSB REGISTER – 0X23B

Bit	R/W	Default	Description
7:1	W	0	Reserved
0	W	0	Horizontal transfer size [8]

DISPLAY DRAM DMA ENABLE REGISTER – 0X23C

Bit	R/W	Default	Description
7:1	W	0	Reserved
0	W	0	Display DRAM DMA enable

HOST DMA DESTINATION VERTICAL POSITION LSB REGISTER – 0X240

Bit	R/W	Default	Description
7:0	W	0	Destination vertical position[7:0] (a line)

HOST DMA DESTINATION VERTICAL POSITION MSB REGISTER – 0X241

Bit	R/W	Default	Description
7:5	W	0	Reserved
4:0	W	0	Destination vertical position[12:8]

HOST DMA VERTICAL TRANSFER SIZE LSB REGISTER – 0X242

Bit	R/W	Default	Description
7:0	W	0	Vertical transfer size[7:0] (a line)

HOST DMA VERTICAL TRANSFER SIZE MSB REGISTER – 0X243

Bit	R/W	Default	Description
7:6	W	0	Reserved
5:0	W	0	Vertical transfer size [13:8]

HOST DMA DESTINATION HORIZONTAL POSITION LSB REGISTER – 0X244

Bit	R/W	Default	Description
-----	-----	---------	-------------

7:0	W	0	Destination horizontal position[7:0] (4 pixels)
-----	---	---	---

HOST DMA DESTINATION HORIZONTAL POSITION MSB REGISTER – 0X245

Bit	R/W	Default	Description
7:3	W	0	Reserved
2:0	W	0	Destination horizontal position[10:8]

HOST DMA HORIZONTAL TRANSFER SIZE REGISTER LSB – 0X246

Bit	R/W	Default	Description
7:0	W	0	Horizontal transfer size[7:0] (4 pixels)

HOST DMA CONTROL REGISTER – 0X247

Bit	R/W	Default	Description
7	W	0	OSG interrupt output enable(Irq PIN)
6	W	0	OSG interrupt enable
5	W	0	hand demand 0 = Demand Mode 1 = Handshake Mode
4	W	0	Service mode 0 = Single Service 1 = Not support
3:0	W	0	Horizontal transfer size [11:8]

HOST DMA ENABLE REGISTER – 0X248

Bit	R/W	Default	Description
7:2	W	0	Reserved
1	W	0	Host DMA enable 0 : Disable 1 : Enable
0	W	0	OSG DMA enable 0 : Disable 1 : Enable

HOST DMA TRANSFER MODE CONTROL REGISTER – 0X249

Bit	R/W	Default	Description
7	R	0	Record DRAM DMA Done status. "1" active
6	R	0	Display DRAM DMA Done status. "1" active
5	W	0	dma_transfer_mode 0 = Single transfer mode 1 = Burst 4 transfer mode
4	W		bmp_wait_pin_en - Refer to "Bitmap Wait Enable 1" Register Bitmap wait enable for interrupt Pin 0 = disable 1 = enable

Bit	R/W	Default	Description
3	W	0	big_endian 0 : little endian 1 : big endian
2	W	0	Host DMA Wait enable 0 : Disable 1 : Enable
1	W	0	Bmp_wait_en - Refer to "Bitmap Wait Enable 1" Register Bitmap wait enable for interrupt 0 : Disable 1 : Enable
0	W	0	Bmp_Big_Endian - Refer to "Bitmap Wait Enable 1" Register "0" : Little Endian "1" : Big Endian

HOST DMA STATUS REGISTER – 0X24A

Bit	R/W	Default	Description
7:4	R		Reserved
2	R		Host DMA interrupt signal "1" active
0	R		Host DMA wait signal "0" active

OSG TOTAL TRANSFER SIZE LSB REGISTER 1 – 0X24B

Bit	R/W	Default	Description
7:0	W	0	OSG total transfer size [7:0] (for Compress Mode)

OSG TOTAL TRANSFER SIZE LSB REGISTER 2 – 0X24C

Bit	R/W	Default	Description
4:0	W	0	OSG total transfer size [15:8]

OSG TOTAL TRANSFER SIZE LSB REGISTER 3 – 0X24D

Bit	R/W	Default	Description
4:0	W	0	OSG total transfer size [23:16]

OSG TOTAL TRANSFER SIZE MSB REGISTER – 0X24E

Bit	R/W	Default	Description
7:3	W	0	Reserved
2:0	W	0	OSG total transfer size [26:24]

HOST DMA WRITE DATA – 0X25E, 0X260, 0X262, 0X264

Bit	R/W	Default	Description
4:0	W	0	Host DMA Write Data

* Single transfer mode use only 0x25e address.

Burst 4 transfer mode use 0x25e, 0x260, 0x262, 0x264 address.

HOST DMA DISPLAY PITCH LSB REGISTER – 0X268

Bit	R/W	Default	Description
4:0	W	0	Host DMA display Pitch [7:0]

HOST DMA DISPLAY PITCH MSB REGISTER – 0X269

Bit	R/W	Default	Description
7:6	W	0	Reserved
5:0	W	0	Host DMA display Pitch [13:8]

HOST DMA START ADDRESS LSB REGISTER 1 – 0X26A

Bit	R/W	Default	Description
7:0	W	0	Host DMA Start Address [7:0]

HOST DMA START ADDRESS LSB REGISTER 2 – 0X26B

Bit	R/W	Default	Description
7:0	W	0	Host DMA Start Address [15:8]

HOST DMA START ADDRESS MSB REGISTER – 0X26C

Bit	R/W	Default	Description
7:6	W	0	Reserved
5:0	W	0	Host DMA Start Address [21:16]

RECORD DRAM SOURCE VERTICAL POSITION LSB REGISTER – 0X250

Bit	R/W	Default	Description
7:0	W	0	Source vertical position[7:0] (a line)

RECORD DRAM SOURCE VERTICAL POSITION MSB REGISTER – 0X251

Bit	R/W	Default	Description
7:6	W	0	Reserved
5:4	W	0	Source bank
3:0	W	0	Source vertical position[11:8]

RECORD DRAM DESTINATION VERTICAL POSITION LSB REGISTER – 0X252

Bit	R/W	Default	Description
7:0	W	0	Destination vertical position[7:0] (a line)

RECORD DRAM DESTINATION VERTICAL POSITION MSB REGISTER – 0X253

Bit	R/W	Default	Description
7:6	W	0	Reserved
5:4	W	0	Destination bank
3:0	W	0	Destination vertical position[11:8]

RECORD DRAM VERTICAL TRANSFER SIZE LSB REGISTER – 0X254

Bit	R/W	Default	Description
7:0	W	0	Vertical transfer size[7:0] (a line)

RECORD DRAM VERTICAL TRANSFER SIZE MSB REGISTER – 0X255

Bit	R/W	Default	Description
7:3	W	0	Reserved
2:0	W	0	Vertical transfer size [10:8]

RECORD DRAM SOURCE HORIZONTAL POSITION LSB REGISTER – 0X256

Bit	R/W	Default	Description
7:0	W	0	Source horizontal position[7:0] (4 pixels)

RECORD DRAM SOURCE HORIZONTAL POSITION MSB REGISTER – 0X257

Bit	R/W	Default	Description
7:2	W	0	Reserved
1:0	W	0	Source horizontal position[9:8]

RECORD DRAM DESTINATION HORIZONTAL POSITION LSB REGISTER – 0X258

Bit	R/W	Default	Description
7:0	W	0	Destination horizontal position[7:0] (4 pixels)

RECORD DRAM DESTINATION HORIZONTAL POSITION MSB REGISTER – 0X259

Bit	R/W	Default	Description
7:2	W	0	Reserved
1:0	W	0	Destination horizontal position[9:8]

RECORD DRAM HORIZONTAL TRANSFER SIZE LSB REGISTER – 0X25A

Bit	R/W	Default	Description
7:0	W	0	Horizontal transfer size[7:0] (4 pixels)

RECORD DRAM HORIZONTAL TRANSFER SIZE MSB REGISTER – 0X25B

Bit	R/W	Default	Description
7:1	W	0	Reserved
0	W	0	Horizontal transfer size [8]

RECORD DRAM DMA ENABLE REGISTER – 0X25C

Bit	R/W	Default	Description
7:1	W	0	Reserved
0	W	0	Copy DMA enable

Recording and Output unit

Introduction

Recording unit is a very important and complicated part of the **TW2880**. Due to the DRAM bandwidth limitation, this block uses a separate DRAM controller and a different set of read / writes agents from display controller to complete its functions. To obtain the maximum flexibilities for the user on the output video stream, **TW2880** has 2 independent recording units (called write agent) for each input channel. One set of write agents is designed for SPOT output and non-real time output and one set is used for real-time record output. The write agents are grouped into two groups and altogether the number of write agents is 32. Each write agent is capable of choosing camera number (incoming material), recording resolution, recording format and location of the video information inside the DRAM buffer.

Functional Description

The block diagram of recording path is as below:

- Down scaler₁ unit is shared with display unit but are used with different outputs. For recording path, following fixed resolution outputs are available: D1, Half D1 and CIF.
- Live video stream are stored into proper places in the DRAM buffer according to register setting. Simple Weave de-interlacing technique is used if frame interleaved format is specified.
- A buffer of 4 frames / 4 fields is used for storing video streams. This is needed to prevent video tearing. **TW2880** has frame detection / repeat circuitry to ensure the proper read / write sequences. In the Quad and 4D1 mode, read and write bank of each channel can be controlled individually to guarantee read / write sequences.
- The write buffers for SPOT work in a similar way as the live video streams. Record ports and SPOTs can use both recording and SPOT write agents.
- Channels with similar setup should group together to facilitate simple read out functions.
- Motion detection circuit use D1 input as the source for each channel but only use the top field to save cost. The results are stored separately in the specific position of the DRAM buffer.

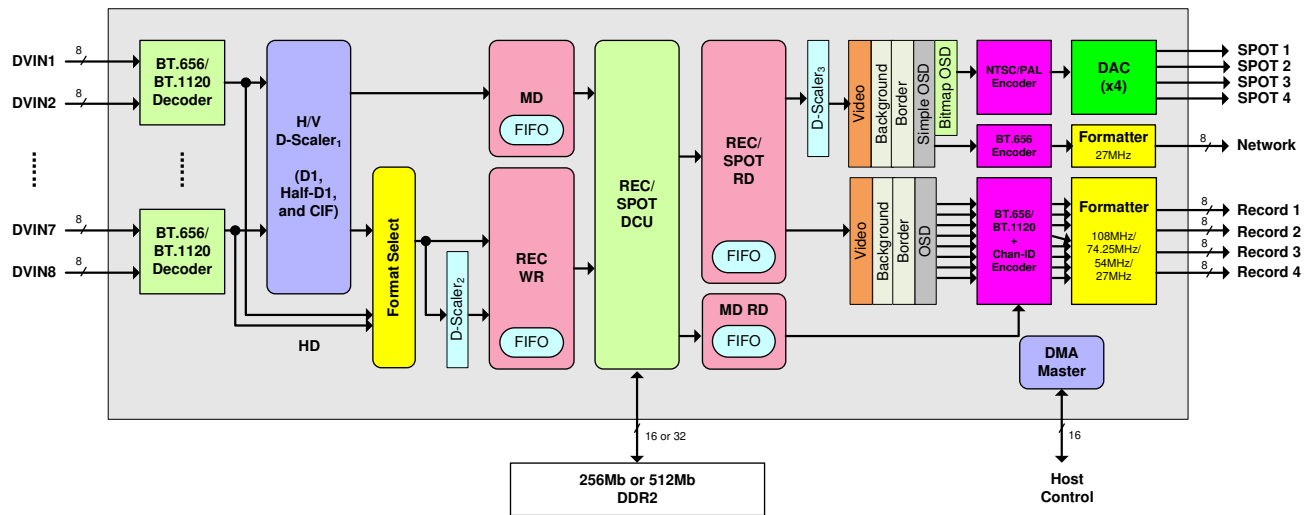

BLOCK DIAGRAM FOR RECORD OPERATION

Picture Format Control

TW2880 recording unit supports SDR memory with 256Mb, 128Mb and 64Mb densities. Memory width can be selected as one of 16 or 32 bits. TW2880 needs two x32 SDRAM or four x16 DRAM to form a 64 bit bus in the recording path. Smaller memory will limit the storing capacity of TW2880 and hence is not recommended.

256 Mbit Memory will form a 2880x1456 canvas (16 bit per pixel and 4 banks) for user to operate. This memory size can support up to 16 channel D1 output in field interleaved format. There are many ways to store the video channels, but based on the read out unit requirements which will

be covered in the subsequent chapters, it is wise to group channels with similar formats and resolutions together to save space. If 16 channel D1 output in Frame Interleaved format is desired, 512 Mb memory are needed.

SDR Memory Mapping (256Mbit)

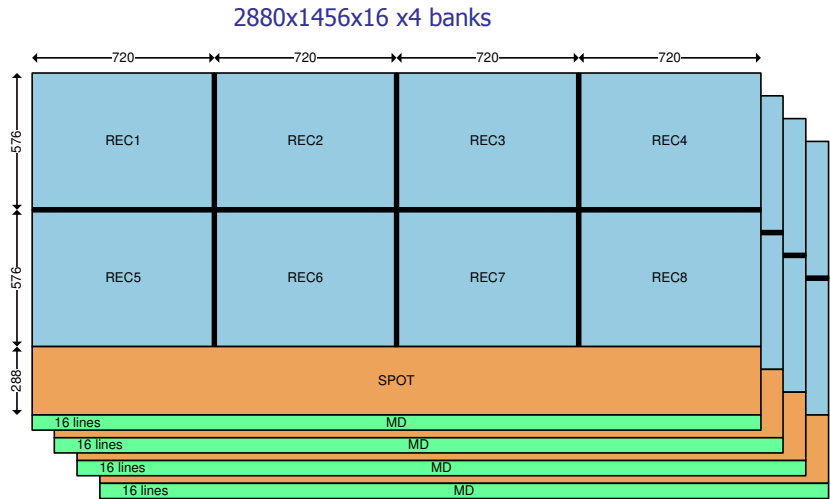

Frame Rate Control Unit

To prevent video tearing on the record output, 4 frames or 4 fields are used to control frame rate. Each write buffers can select their own read side bank reference from 9 record read ports and 4 SPOTs. In the quad mode and 4D1 mode, each channel has separated frame rate control unit.

Record Channels Arrangement Example

Following are some memory allocation examples for TW2880.

8 D1 CHANNEL FRAME INTERLEAVED REAL TIME OUTPUT

This mode is used for newer systems when the resolution and frame rate are not to be compromised. To output the video data to the CODEC, the read out unit can be configured at running at 108 MHz (two ports, frame interleaved) or 54 MHz (four ports, frame interleaved) or 27 MHz (8 ports).

8 D1 frame interleaved real time record

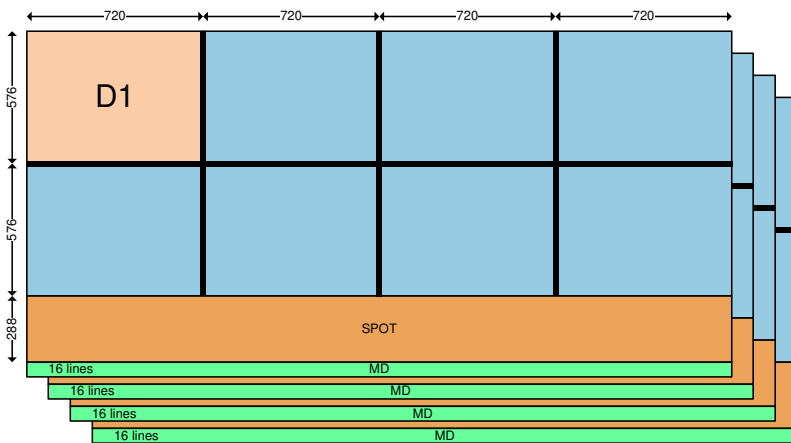

16 D1 CHANNEL FIELD INTERLEAVED REAL TIME OUTPUT

This mode is designed for newer high-end system as all 16 channels are output in D1 resolution. To output the video data to the CODEC, the read out unit can be configured at running at 108 MHz (four ports, field interleaved) or 54 MHz (eight ports, field interleaved).

16 D1 field interleaved real time record

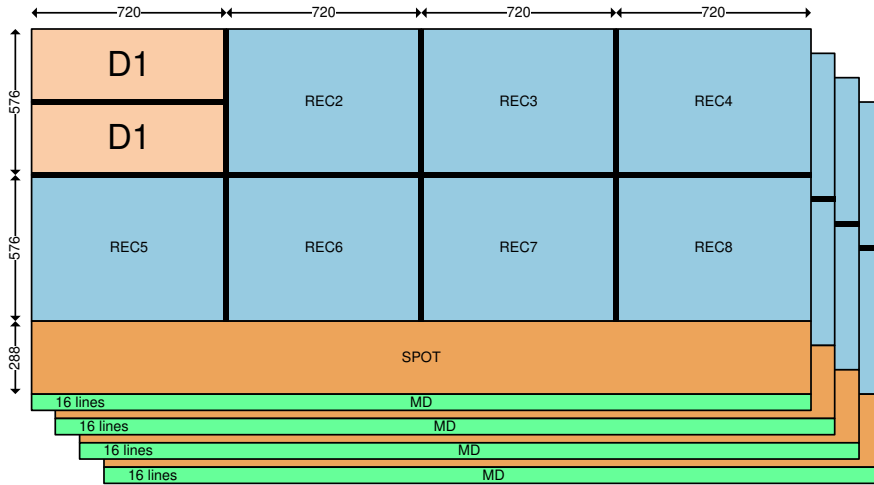

16 CHANNEL MIXED FORMAT REAL TIME OUTPUT

Here is example showing how several different resolution of video channels are saved into the TW2880 recoding memory. Notice in this setup all 16 write agents are deployed.

16 Mixed frame interleaved real time record

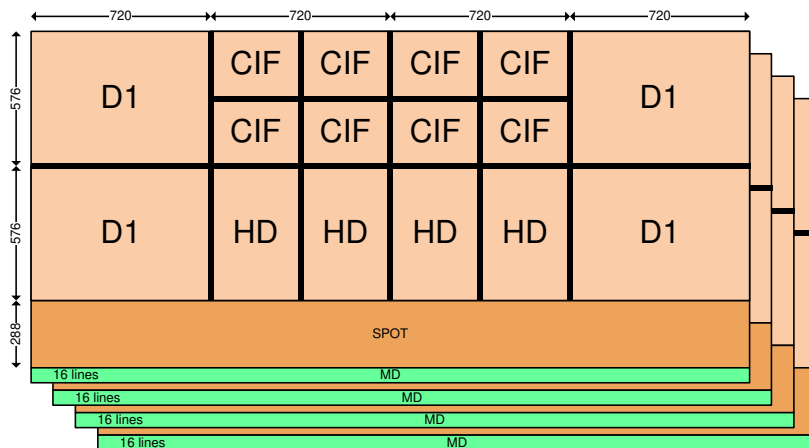

16 D1 CHANNEL FRAME INTERLEAVED REAL TIME OUTPUT

This mode is designed for newer high-end system as all 16 channels are output in D1 resolution. To output the video data to the CODEC, the read out unit can be configured at running at 108 MHz (four ports, frame interleaved) or 54 MHz (eight ports, frame interleaved).

16 D1 frame interleaved real time record

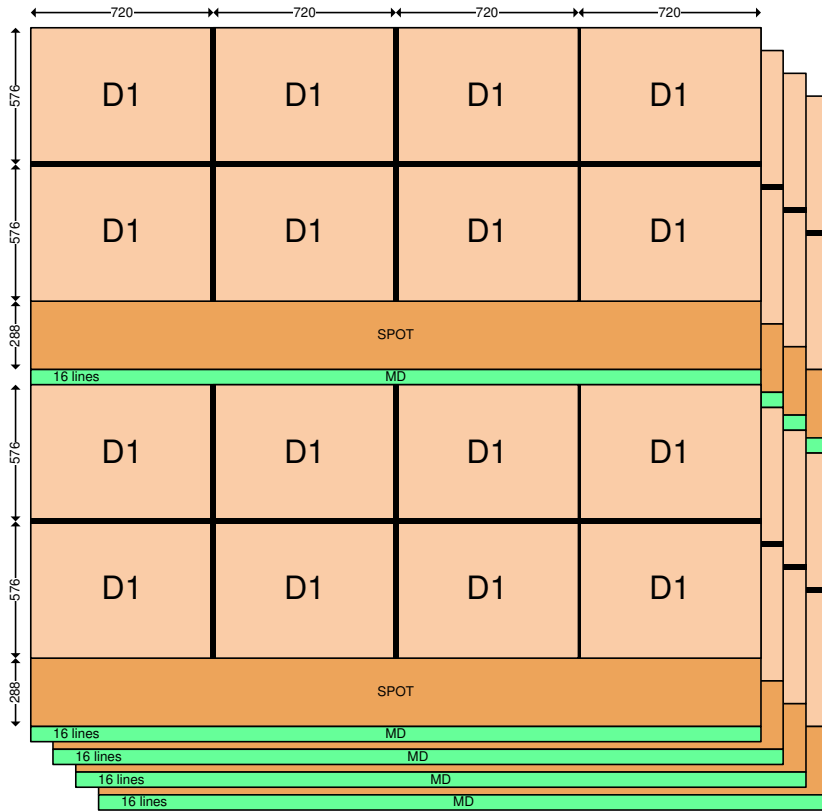

SPOT MONITOR MEMORY SPACE

In the 256 Mbit memory, SPOT can use 2880x288 reserved space. This capacity is big enough to accommodate 4 D1 output for four SPOT. If using quad or half D1 mode to accommodate multi-channels, make sure the recording positions are entered correctly. In the 512 Mbit memory, SPOT can use up to 2x2880x288 memory space.

SPOT memory space

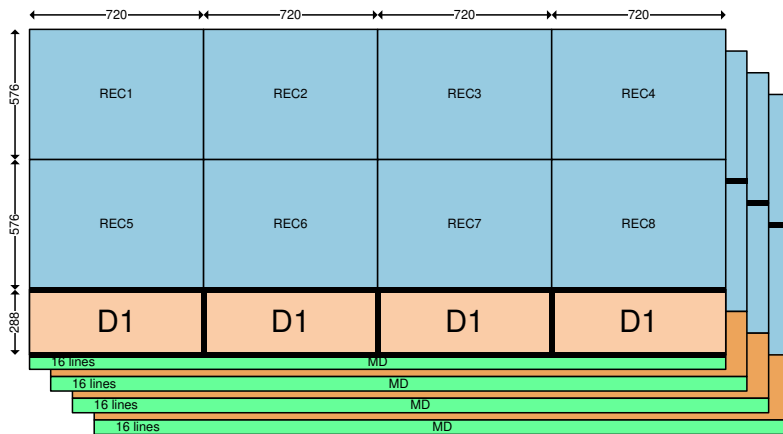

MUX SDRAM Mapping (detailed)

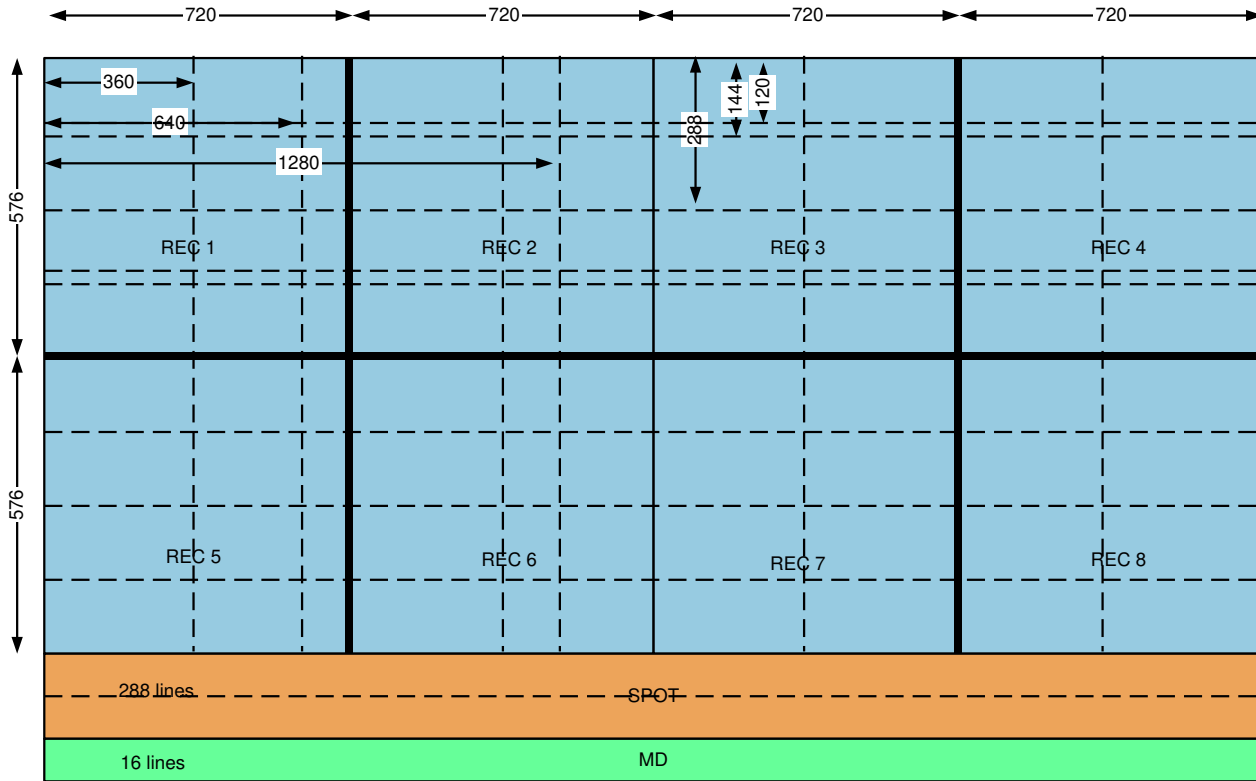

RECORD POSTIONS IN DETAIL

The above diagram shows all kinds of possibilities in choosing channel positions. These positions are selected in recording buffer control register B where the user select a pre-determined horizontal and vertical positions. Because there are too many possible locations to choose from so please refer to manual for actual settings. The offset within a channel is also possible. This is done by changing the starting positions of each channels (Xstart and Ystart). The Xsize and Ysize is determined by the output format. If the size is small than the recording format chosen, cropping will occur. The variable starting position is used to chop off unnecessary artifact in the beginning of the channel.

SPOT WRITE BUFFER

SPOT write buffers function the same way as recording buffer. The only difference is vertical location. SPOT write buffer can be used by recording unit as a possible inputs.

Channel Record Position Control

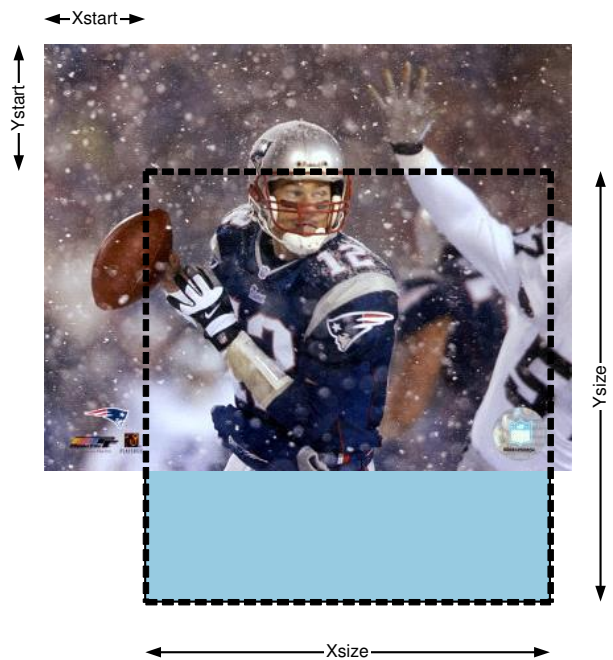

Recording Unit

INTRODUCTION

TW2880 provides very powerful and versatile recording options and interfaces to the backend CODEC. The functions and output formats for each port are discussed in details in the subsequent sections. There are eight regular output units' shared 4 output pin ports and one network output unit in TW2880. Except the network port, which is usually run at 27 MHz, user can configure each port independently to run at different frequencies and output formats. However, due to the bandwidth limit, not all the output ports can run at the highest frequencies at the same time. The last five port (port 5 to port 9) are equipped with a flexible output option that even one frame per second for a certain channel is supported.

RECORD OUT FORMAT CONTROL

The basic output format of TW2880 is followed the BT.656 standard with EAV-HBI-SAV-ACTIVE style of coding. The D1 output sequence is illustrated in the next two figures. The differences between each output format lies in the number of bytes in each format and flags in the HBI area. In the subsequent sections, when we mention a field output or frame output, what we really meant is a series of EAV-HBI-SAV-ACTIVE lines shifting out follow these rules and output continuously to the outside world.

Several things determined the output video stream:

- Output frequency: Each port can be configured to run at 108, 54 or 27 MHz. Higher the frequency, higher the data rate and hence more channels supported.
- Output format: Three formats are supported, (1) Field interleaved. (2) Progressive Frame interleaved (3) Interlaced Frame interleaved
- Output resolution: Four resolutions are supported: D1, special CIF, 4D1, 720p and 1080i or 6VGA.
- Output channel selection: This will determine which channel will output from this channel. Because the channel format has been set in the recording side, this setting is actually adjusting the read out DRAM area and order.

BT.656 8-BIT PARALLEL INTERFACE DATA FORMAT FOR 525/60 VIDEO SYSTEMS

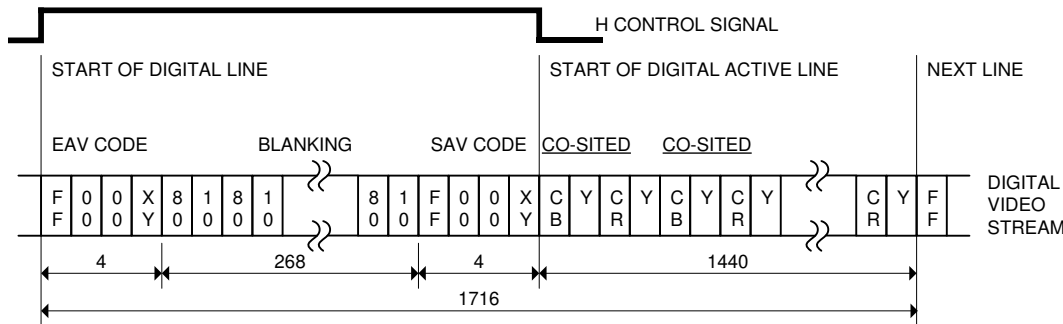

BT.656 8-BIT PARALLEL INTERFACE DATA FORMAT FOR 625/50 VIDEO SYSTEMS

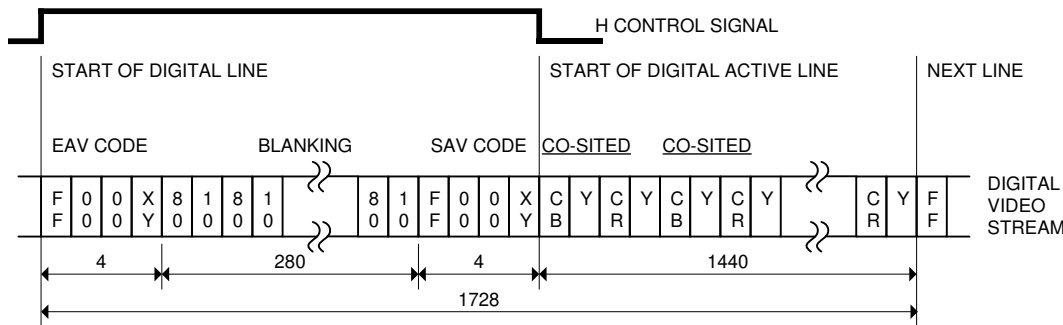

D1 VIDEO FRAME DATA ARRANGE

Total byte number in a NTSC frame is: $1716 \times 525 = 900,900$ Bytes where PAL frame has: $1728 \times 625 = 1,080,000$ Bytes. One thing needs to point is the vertical resolution is 525 lines divided as 262 / 263 in the NTSC and 625 lines divided into 312 / 313 in PAL. If frame-interleaved sequence is sent via this interface, the TW2880 will not toggle FLD flag in the VBI status word like when TW2880 send out the interlaced sequence. For a multi-channel sequence, the output clock will get double or quadruple to maintain the output frame rate. The actual frame data will be sent out sequentially follow CH1-CH2-CH3 style and on to the next frame.

CIF VIDEO FRAME DATA ARRANGE

TW2880 support a special mode where the output resolution is a quarter of the original D1 frame. The mode is called CIF frame. In NTSC case, the number of byte in a CIF frame is: $900,900 \text{ byte} / 4 = 225,225$ bytes. This number cannot be evenly divided by two. The number of bytes in each section is difficult to assign. TW2880 is using 828×272 for a CIF frame with the fourth frame's VBI includes a extra 36 clocks.

$828 \times 272 \times 4 + 36 = 900,900$

As for PAL, the number is $750 \times 360 \times 4 = 1,080,000$ Bytes.

The CIF is only different in the number of bytes in the output format. The rest is the same as the normal frame output. This format is especially useful when a great number of channels need to be output in a single port. For example, a port running at 108 MHz with a 16 channels in CIF resolution can be accomplished.

16-BIT VIDEO FRAME DATA ARRANGE

In addition to the 8-bit BT.656 interface, TW2880 also supports 16-bit video interface with external syncs (BT.601) or embedded sync (BT.1120) format. Data port in both format are divided into upper byte as Y data and lower byte as C data. For the BT.1120 format output TW2880 will output the correct EAV, SAV syntax with the 10-bit extension. For the BT.601 external sync will get sent out. Both formats can be program into different timing and clock rate to send out non-standard video stream.

RECORD OUTPUT METHOD

Two kinds of output methods are provided: real time mode and switch mode. The most important feature provided by the real time mode is synchronization. The different channels in the same video output sequence are guaranteed to start from the beginning. Other benefits include less interrupt to the host and easy data management. Switch mode is provided to user don't care about the frame but care much flexibilities especially in the low frame rate low storage requirement environment.

MULTI-MODE FORMAT CONTROL

This is a special mode to let user achieve the ultimate flexibility in outputting recording channel information. The regular port (port 1 to port4) can select between 1 to 4 source channels. The port 5 to 9 in TW2880 has a larger (128) than normal (4)

NTSC, D1

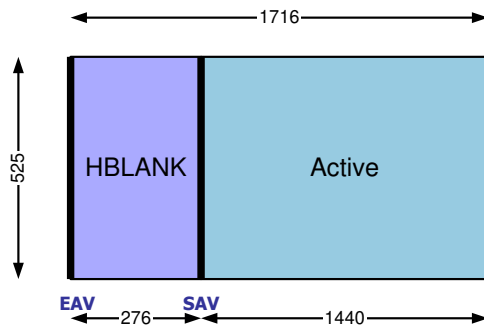

PAL, D1

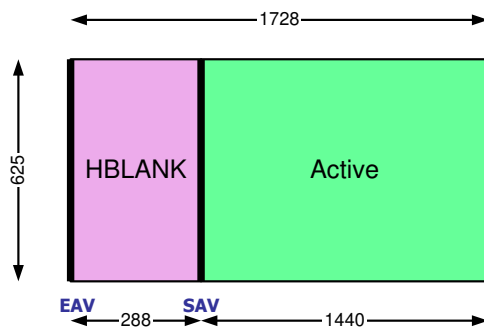

NTSC, CIF

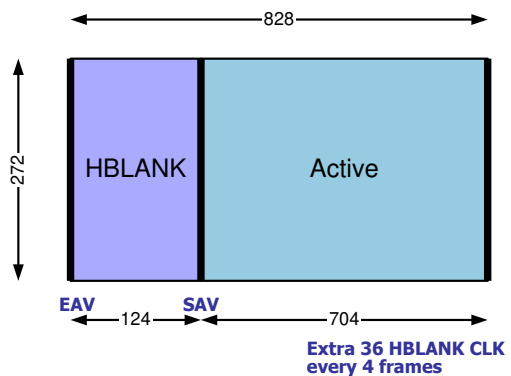

PAL, CIF

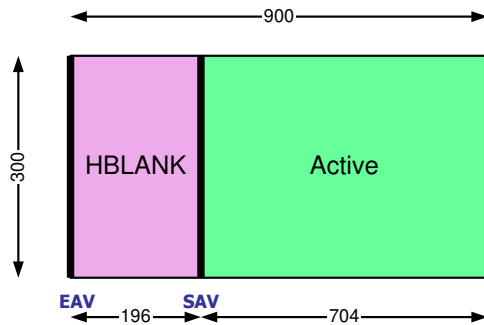

source channel select option. So if configured as running at 27 MHz, user can reduce the recording frame rate to less than one frame per second. Although the channel selection is quite flexible, similar resolution item must be grouped into a single frame except D1 selection. For example, a QUAD frame will consume four CIF selections in the list and if not satisfied garbage data will appear in the sequence. That is to say, if quad frame is output through the sequence, only 32 frame can be entered.

RECORDING FORMAT EXAMPLE

The following diagrams are the recording resolutions and sizes that TW2880 supports. D1 frame means record in full D1 resolution and do frame interleaved output. This is implied when the vertical sync comes, half of picture is sent followed by the other half. Frame mode has two output methods: progressive and interlaced. D1 field means record in full D1 resolution and do field interleaved output. The odd scan lines will be sent first followed by even scan lines. TW2880 can record the image with high definition size included 1080i and 720p.

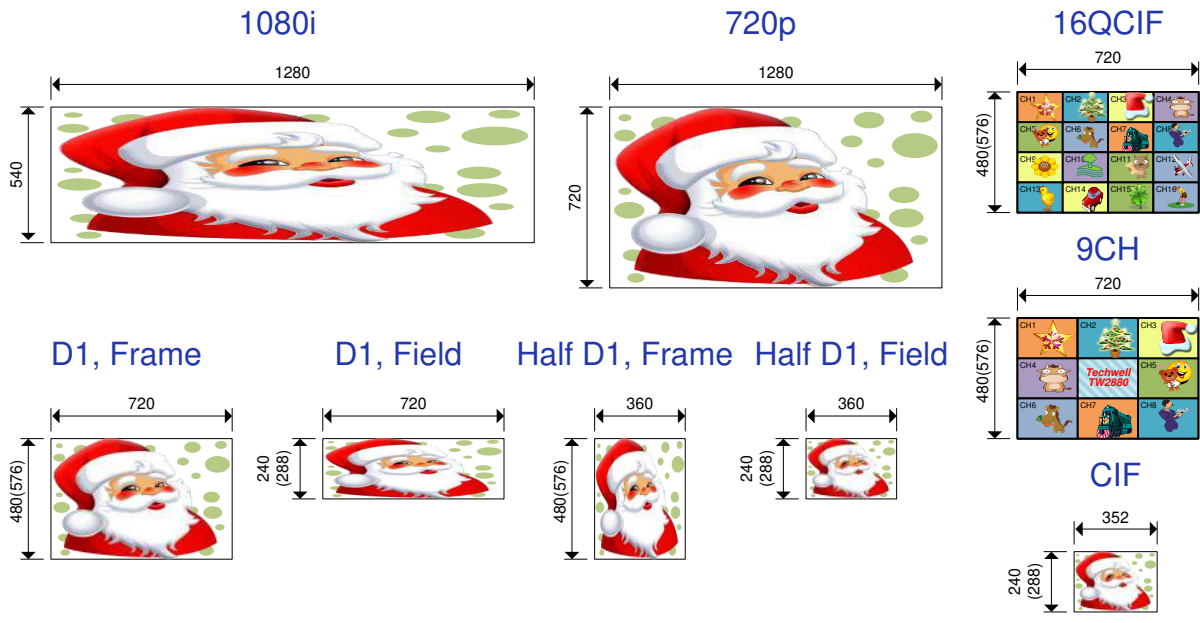

RECORD OUT CHANNEL OUTPUT EXAMPLE

The following is an illustrated example about the possible output sequence of one port running at 54 MHz.

Record out Option @ 54 MHz

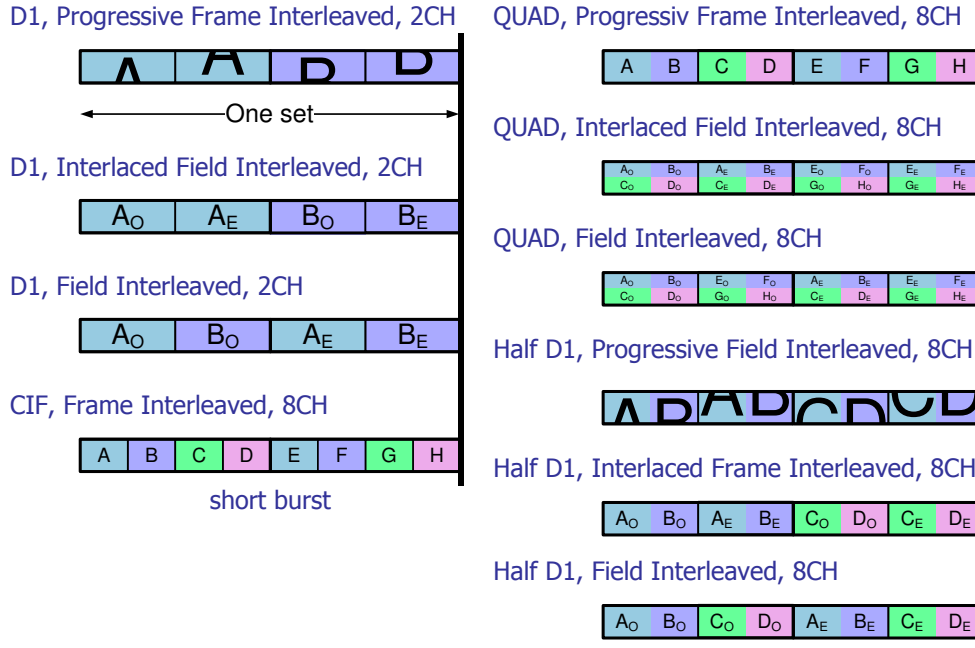

Multi-mode record out @ 27 MHz

Progressive Frame Interleaved

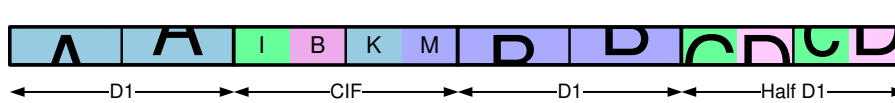

Interlaced Frame Interleaved

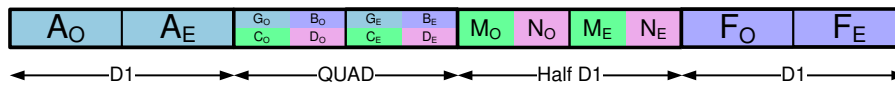

Field Interleaved

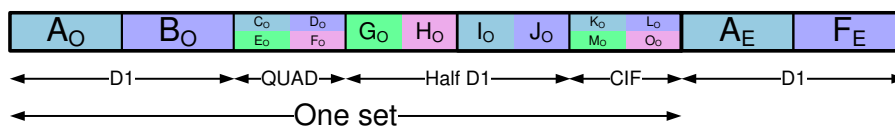

From the above sequence, one can easily tell the difference between frame-interleaved and field-interleaved. This also has great impact on the receiving CODEC because if synchronization between the channels happens, FMI mode will repeat the same frame and FLI mode will repeat the same field and might causing problems for the backend. The scan line output order in the FMI mode has two choices, the default one is the scan lines are output sequentially and followed the picture's nature order. In addition to this progressive FMI mode, TW2880 also support another method which the output scan lines are followed the even and odd field orders into a so called "interlaced FMI mode". This mode is designed to accommodate different CODEC input format.

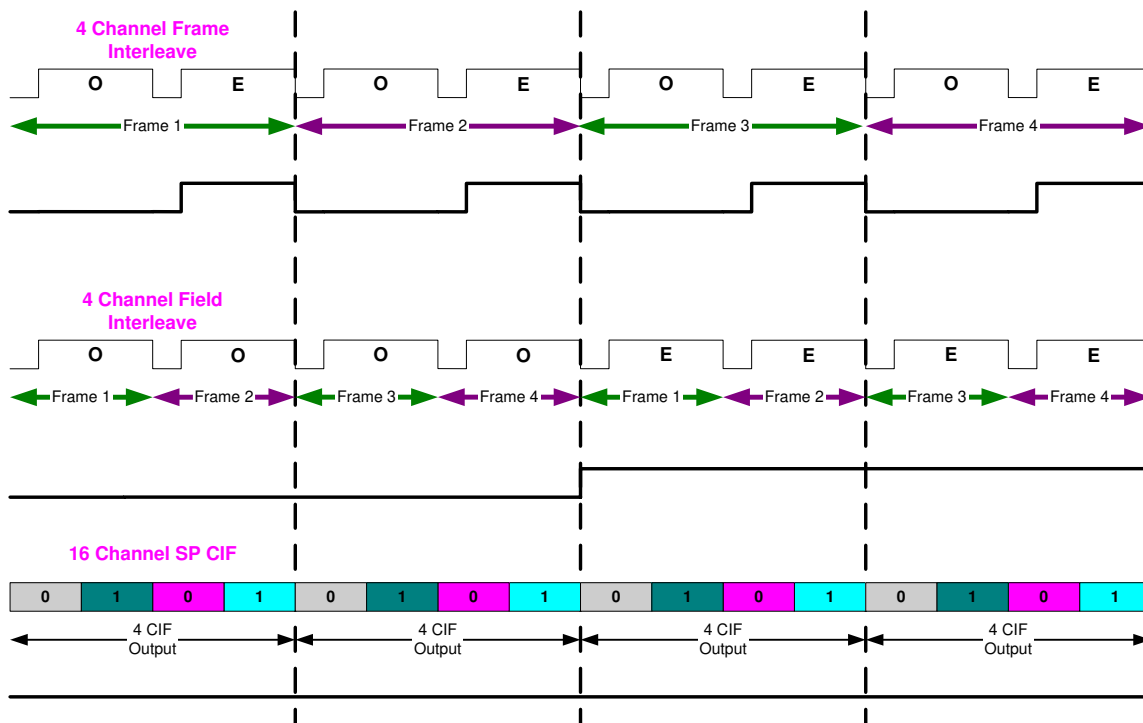

RECORD PORT MISC. ITEMS

Port 1-4 has only four sources. User can specify source number from one to four. Output resolution if selected as CIF, this port will output four small CIF frames according to the source registers. If specify as D1, three read out options are available: straight, splitX and splitY. The first method is this port will output a D1 frame based on the source register's origin and does not care about the image size of this source. So using this method it is possible to output all 16 channels in just 4 QUAD. The next mode is used when the two source images want to output in a single D1 frame. The last mode is using together with splitX and output a CIF image as QUAD. The main difference is the location of these sources needs not to be adjacent in the DRAM memory map.

Multi mode port has 128 entries to constitute a customary output sequence. This sequence also has the straight mode and the automatic mode for grabbing the images. The table sequence programming can be done even during the port is enabled. The register write operation will always has the priority over the internal state machine. User can adjust the sequence whenever they seems fit.

Special Output Format

The previous section is mainly discussing output format in D1 or in special CIF resolutions. These two formats can be accepted by most CODEC manufacturers in a multi-channel environment. However, there are situations where CODEC manufacturer does not want to decode EAV-SAV field mark and still want to do multi-channel encoding. For this kind of application, TW2880 supports two more modes to output multi-channel material but with high strobing clock (i.e. 108 MHz), namely, the 4D1 mode and BT.1120 (6VGA) mode. These two modes are the products of utilizing the new transmission standards in the HD era.

Basically, 4D1 mode evolves from the old BT.656 mode to accommodate four D1 channel at the same time. It keep the EAV-SAV field mark but enlarge the horizontal pixels to 1440 so two D1 frame can be transmitted. In the vertical area it follows the interlaced format that odd field of the first two D1 streams are transmitted followed by the even fields.

The output clock has to set to 108 MHz if real-time recording is desired. Lower output clock will cut down the frame rate.

6VGA (BT.1120)

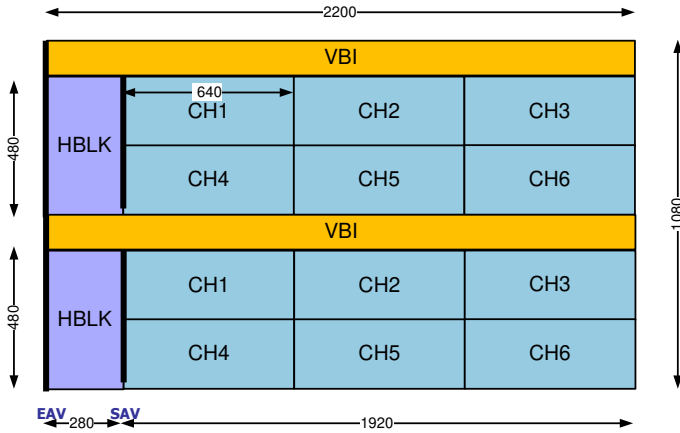

4D1, NTSC

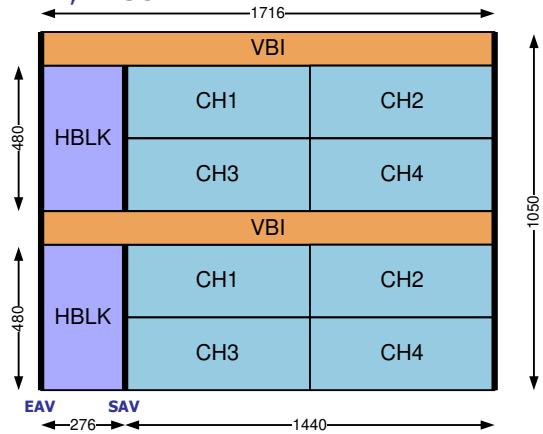

4D1, PAL

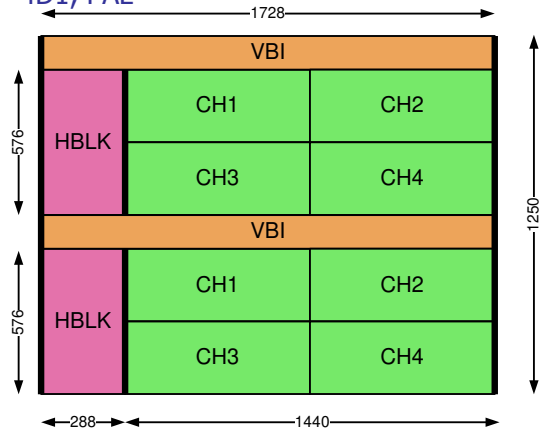

The 6VGA mode is basically the same except the data arrangement and the output clock. The storing selection needs to set as VGA (640) and use Hstart to center the channels. Output clock has to be 148.5 MHz to make it BT.1120 legal.

Record Port Capability Chart

FORMAT	SPECIAL	FIELD INTERLEAVED	INTERLACED FMI	PROGRESSIVE FMI
CIF	○	N/A	N/A	N/A
D1	N/A	○	○	○
4D1	N/A	○	○	N/A
BT.1120	N/A	○	○	N/A

* ○ : Support, N/A : No support

One thing which needs to be pointed out is that the user has the highest flexibility when composing the D1, and 4D1 recording streams. For example, a D1 resolution stream can have a quad and the 4 channels needed can be reside in any legal locations of the DRAM buffer. Similarly, 4D1 resolution can be used to send 16 CIF through one output pin port. BT.1120 output stream, however, due to the 6 channels nature, does not have this freedom. All channels in the streams needs to be put into adjacent locations.

Multi-mode Record Port Programming Example

Unlike normal record port 1, 2, 3, 4 can only handle 4 channel images, multi-port 5,6,7 8 can accommodate 128 channel images in a single output stream. By using these options, user can composite the ultimate video stream to the subsequent back end. The source list of the multi-port output is controlled by the three control registers, take port 5 as an example, it is register 0xC35, 0xC36 and 0xC37. 0xC35 specify the location of the table and 0xC36 specify the recording buffer number (not to be confused with the channel number). The reason not to use channel number here is: for one channel user can select different size of image to store. So the important thing to record here is the buffer number. 0xC37 stores the number of valid entry in the table. It doesn't has to be full length.

Recording port should be off (not enable) when inputting the source into the table. If users choose the output resolution to be D1, sources smaller than the D1 size will be merged into one D1 frame based on the current size. If users choose the output resolution to be CIF then entry table entry represent a source. This is done for obvious reason. Please pay attention when input the source list into the table otherwise garbage data may appear at the output.

There is no restriction on how to arrange the source list other than the resolution limit described above. Table mode is designed for covering the most of the channel with the lease amount of video data generated in regular non-alarming use. User can adjust or repeat a same buffer several times to increase the total coverage based on importance. Real time coverage is also possible but user needs to remember since output clock has only few selections so it limits the number of sources.

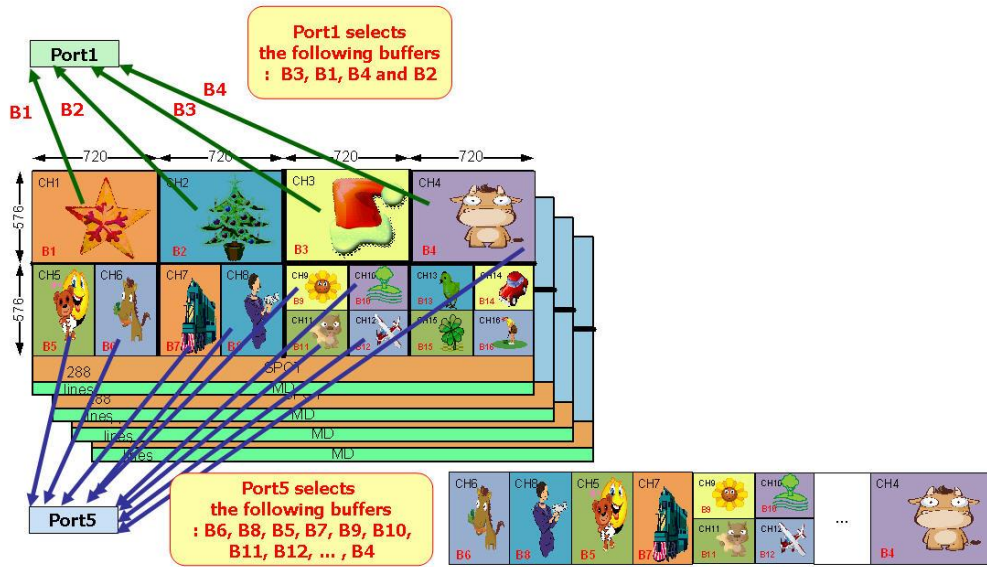

Output Port

INTRODUCTION

8b Port output @ 54 MHz

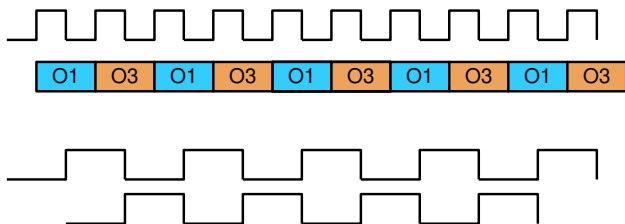
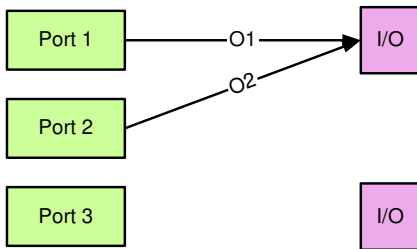

2 real time D1 are sent

16b Port output @ 54 MHz

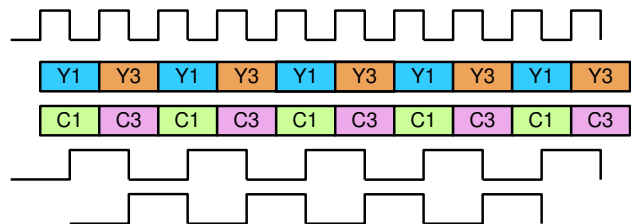
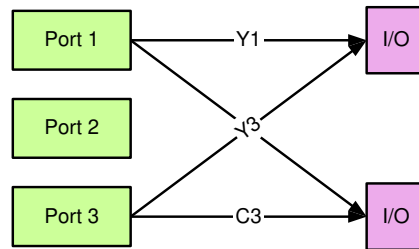

4 real time D1 are sent

TW2880 has 9 record units and 5 set of physical ports, total 54 pins ($5 * (8+1) + 3 * 2$). The main reason not to let each record unit has its dedicated output pins is to save pins. The output data and clocks have several rather complicated relationships. The following paragraph is used to clarify this:

Suppose we set the two output ports running at 54 MHz which will output 2 real-time D1 stream on each port. The user can set the output port running at 54 MHz. For 8 bit mode, the output data stream will run at 108 MHz with

two out-of-phase clocks running at 54 MHz to differentiate the video data. The diagram on the right shows the relationship between the output data and the output clock. One pin set can output two 2-D1 streams to two CODEC chips. In the 16 bit case, the channel number is double so it can support two 4-D1 streams. If the user set the output port running at 27 MHz, for 8 bit mode, the output data stream will run at 54 MHz and one pin set can output two D1 streams to two CODEC chips. So the output channels are cut in half in 27 MHz mode. Other things needed to know for the user:

- If the associated output ports in a pin set is disabled then number of output channels is cut in half.
- The output rate of the two associated ports must be set to the same value.
- Port 9 is used for network output so its own I/O pins. The output rate can go up to 108 MHz if necessary but since it is sharing bandwidth with other unit so the total performance is subject to active setting.

8-BIT MODE

This mode basically deal with BT.656 embedded sync. format. It is possible to support 4 output streams running at 108 MHz and output 16 channels using four recording ports or 8 output streams running at 54 MHz (two clock multiplexed method) and output 16 channels using four recording ports, or 8 output streams running at 27 MHz (two clock multiplexed method) and output 8 channels using four recording ports.

16 channel + Network
8b output @ 108 MHz

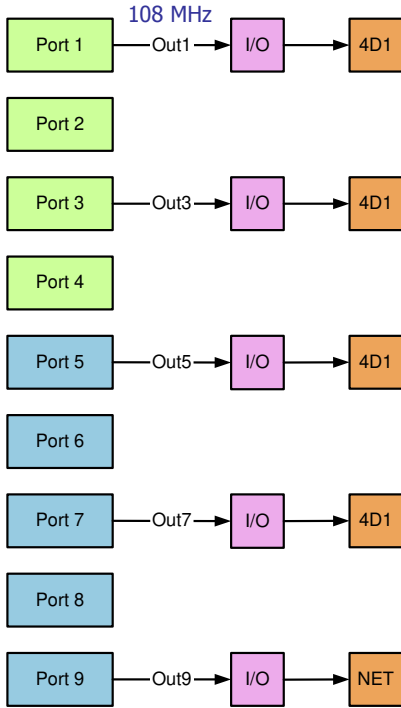

16 channel + Network
8b output @ 54 MHz

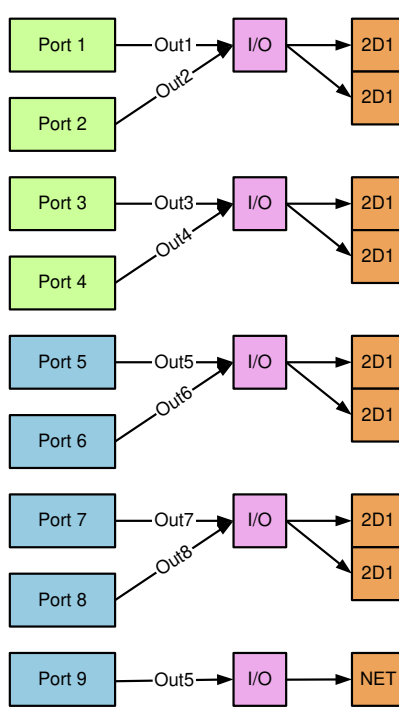

8 channel + Network
8b output @ 27 MHz

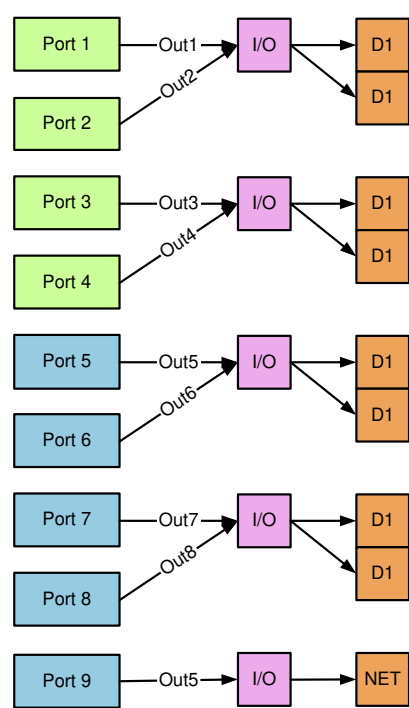

16-BIT MODE

TW2880 also supports 16-bit output mode where the Y and C data are separated. This setting actually includes support of BT.601 with external sync. and BT.1120 with embedded syncs. For setting at 54 MHz, TW2880 can send out two 4 D1 streams into a single CODEC using two ports. The clock and the data arrangement is mostly the same as in the corresponding 8 bit setup.

16 channel + Network
16b output @ 54 MHz

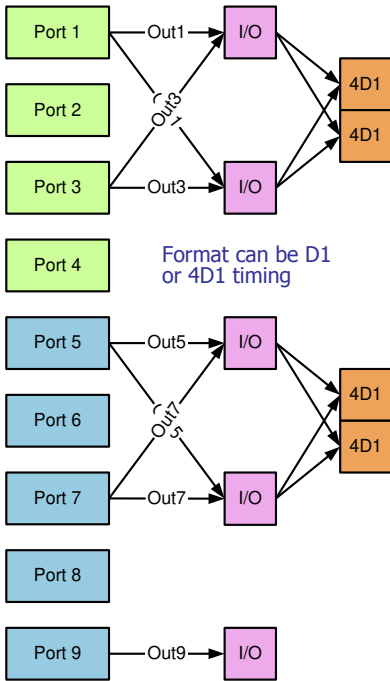

8 channel + Network
16b output @ 27 MHz

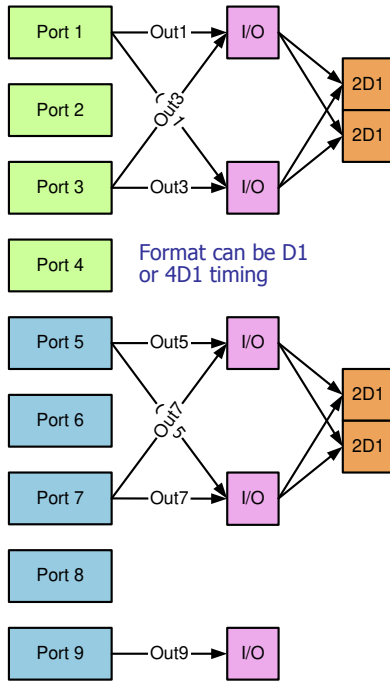

12 channel + Network
16b output @ 74.25 MHz

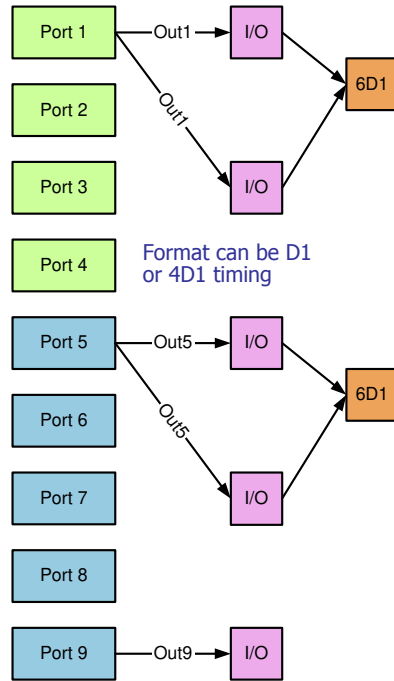

16-BIT COMPONENT MODE

In addition to the traditional 16 bit output mode, there is a new 16 bit mode which is designed specifically for new generation high speed CODECs. With this mode, if running at 108 MHz, TW2880 can generate 16 bit 8D1 frame or field interleaved video stream. The idea is simple, setup one recording unit the usual way but instead of output 8 bit Y / C component stream sequentially to the outside, it will output both Y / C components at the same clock to the subsequent modules like OSD and embedded sync module.

This means the FIFO output rate doubles as comparison to the normal mode. Because the output speed is clocked at 108 MHz for both component output so 8 D1 channel real time data can be supported. One thing to remember is because the number of output channel is larger than four so the recording unit used is limited to 5, 6, 7, and 8. All four output resolutions are supported but choose BT.1120 will result to a big 8D1 frame (6864x960 for NTSC).

16b Port output @ 108 MHz

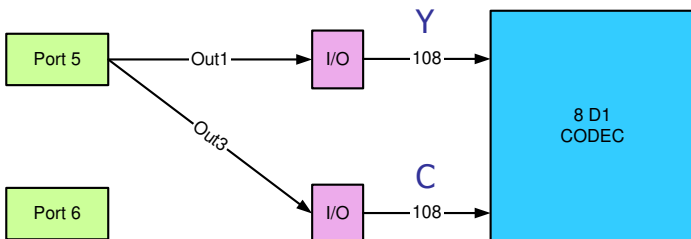

To use this mode, after setting the recording buffers and the output options, user need to set the responsible bits in register 0xCFO to enable this special component mode and choose the desired video component. As stated before, only two port 5, 6 are needed for output 16 channel D1 real time to the CODEC. All output resolutions are supported except 6VGA mode, the resulting streams will have different effects based on the resolution chosen. For example, D1 stream will have 8 D1 channel come out before it will repeat itself. NTSC frame interleaved 4D1 mode will have two 1440x960 frame output before repeating itself. Please see the following diagram to for clarification.

Record out Option @ 108 MHz, 16 bit

Progressive Frame Interleaved, 8CH D1



Field Interleaved, 8CH D1



Special CIF, 32CH, short burst

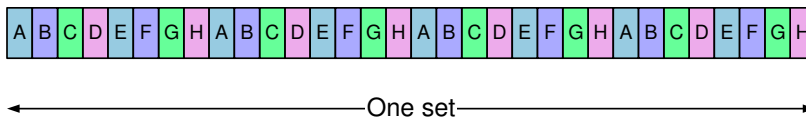

Record out Option @ 108 MHz, 16 bit

Interlaced Frame Interleaved, 8CH 8D1

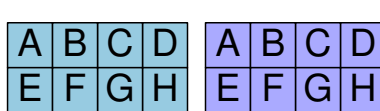

Field Interleaved, 8CH 8D1

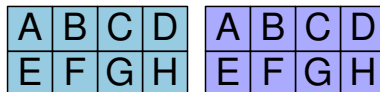

← One set →

Interlaced Frame Interleaved, 8CH 4D1

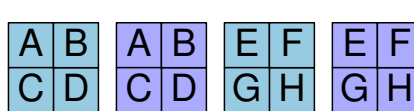

Field Interleaved, 8CH 4D1

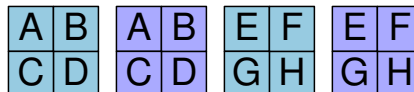

← One set →

FIELD SWITCHING MODE

Field Switching Record out Option

8CH D1 @ 27, 54, 108 MHz

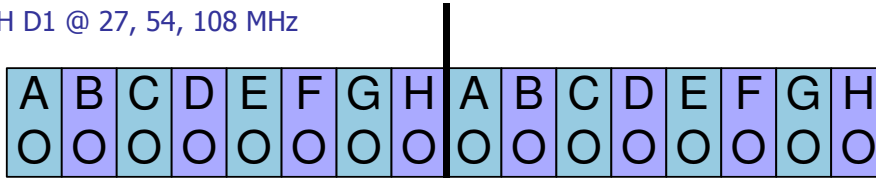

16CH HD1 @ 27, 54, 108 MHz

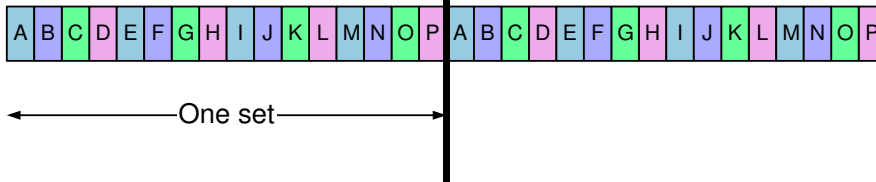

Field switching mode is designed for generating low bit rate stream to cover more channels at half of the normal data rate. To use it, users need to set registers 0xCF1-0xCF4 to determine which buffer is in field switching mode and which field get recorded, the second thing is set the port run at field interleaved mode then the resulting stream will be in field switching mode. D1, half D1 and quad are all legal output format. Another thing to remember is while user still can select output frequency and channel number in a stream, most of the time the resulting stream are non-real time because the channels covered. This means each field which representing a channel in the resulting stream may come from different input field number.

32 BUFFER MODE

The 16 SPOT buffers can be used by the recording port 5-8 to increase the total available buffer to 32. This is done by first setting the corresponding bits in SPOT Buffer Control Register 0xCCE - 0xCF to one. Setting these bits are to change the SPOT buffers feedback input in the frame rate control unit. After setting these bits, user will have 32 buffers at their control to create more options. In the buffer naming, 0x0-0xf is the original recording buffers and the 0x10-0x1f is the spot buffers. For example, user can set buffers 0x0-0xf to record D1 resolution and output 16 channel D1 stream while having a special 16CIF video stream to go out using SPOT buffers at the network port. SPOT function is supported if DRAM bandwidth is enough (182 MHz).

OUTPUT PIN SOURCE CONTROL

The source1 and source2 of each output pin set are programmable. The source1 is control by register 0xC4E-0XC51 bit 3 to 0. The source2 is controlled by register 0xCF5-0xCF6. Please see the following diagram, each port can select output from 16 sources. This will make the pair matching in 16 bit mode and byte interleaving in the two CODEC mode easier to program.

MUX Selection

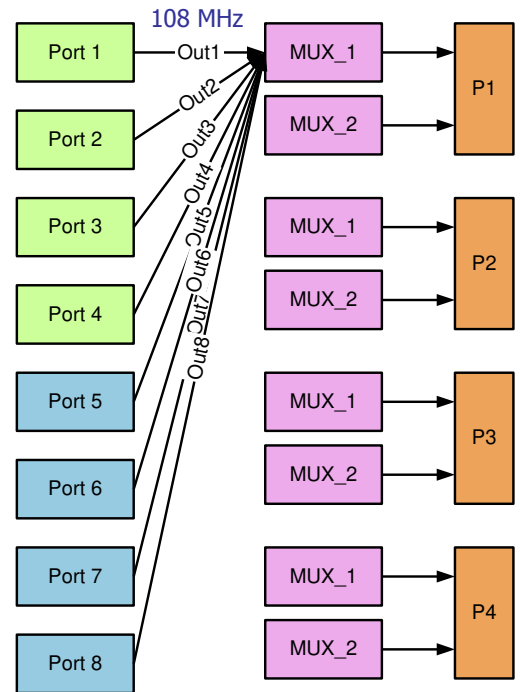

FIELD SWITCHING QUAD MODE

Based on the field switching mode, a special field switching quad mode is available for use. This mode is created by setting the write buffer side in half D1 field mode and the recording port is in interlaced frame interleaved mode in D1 resolution. To visual result is similar to the normal QUAD mode but has several advantages over the normal mode: **The bandwidth saving is very obvious as one field is dropped.**

No need to worry odd / even field reversed because only one field is used.

Image looks sharper because only one low pass filter is used.

This combination can be used in recording output and SPOT output. One thing to remember is you can extend the usage to half D1 mode (except the image is horizontally divided) and divide-by-8 mode.

SYNCHRONIZATION MODE

The table output port 5 to port 9 has a special mode for the TV wall customers. These ports' output can be synchronized together by setting register 0xcfo bit 0, 2, 4, 6. After setting the corresponding bit the timing of the output port 6, 7, 8, 9 will be controlled by port 5. User can choose any combinations of port to be synchronized together. Another method to synchronize any channels is after setting the output port, do a software reset. After this reset all enabled port will have the same timing if they are configured under the same conditions. By doing this will put a heavy burden on DRAM bandwidth requirement so synchronization is not what you need, after software reset you need to disable and enable the port to scatter the requests.

MULTI-MODE

The dual monitor output from the display control unit has an option to route through record port. To use this mode users need to set the dual monitor controller in 1080i timing and set register 0x218 bit 7 to 1. The dual monitor output will come out from pin port 1, 2. This mode enables user to record the image from Live inputs or playback inputs without installing the recording memory.

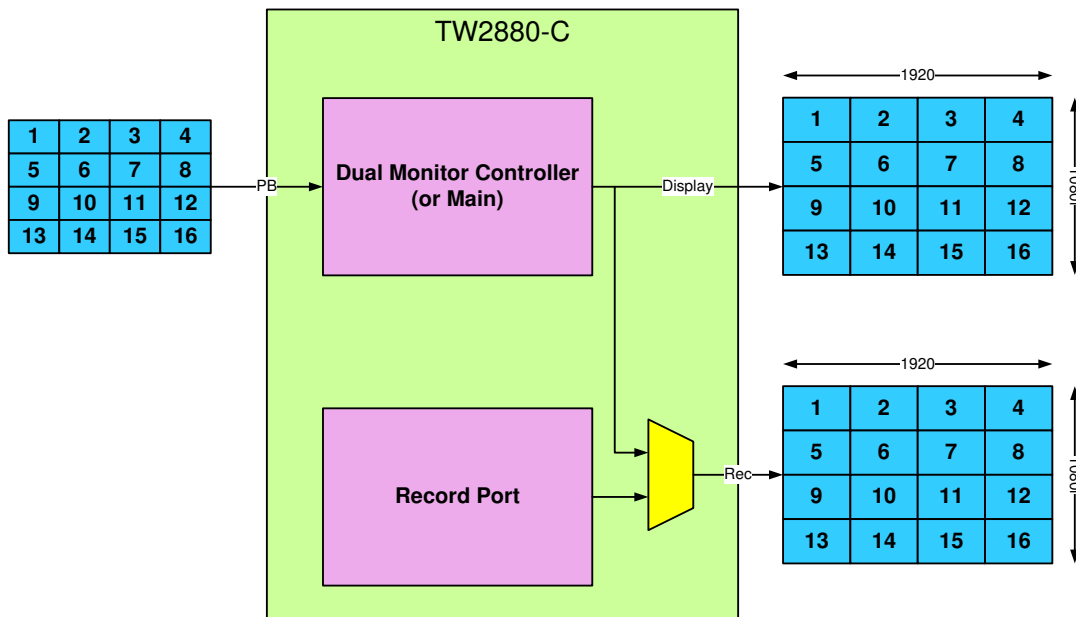

Multi-mode Application Example 1

Another application of this capability is cascading. User now can cascade two TW2880-B chips together to form a 32 channel system. It is illustrated in the following diagram. With the variety options that TW2880-B provide, user can chose to install memories in different places and sizes to tailor to their own needs.

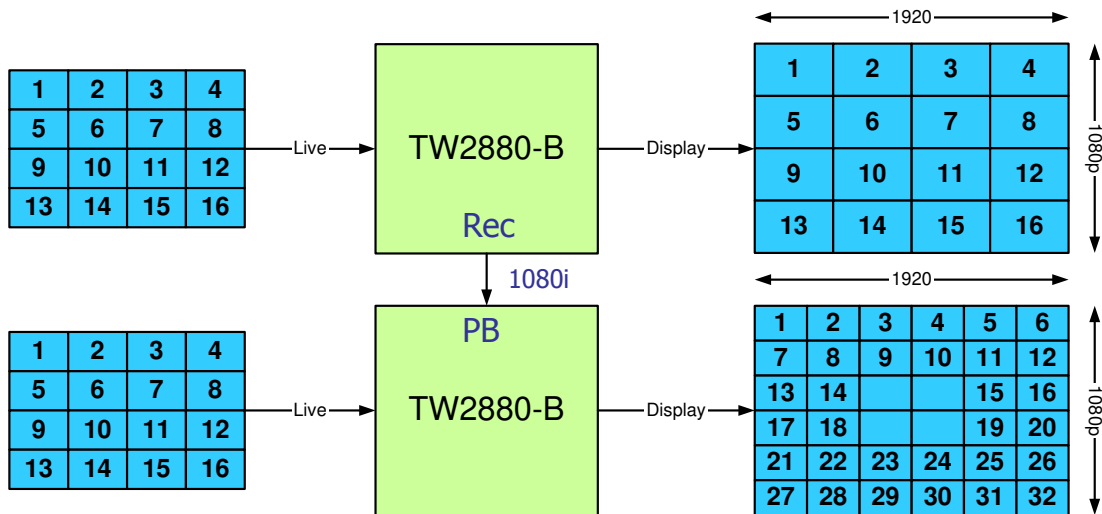

Multi-mode Application Example 2

CONCLUSION

Together with 8 bit mode, TW2880 provides a wide range of connecting options for the backend solutions. One thing to remember is if the new BT.1120 mode is desired, the output will have BT.1120 EAV-SEV syntax output during the sync. period. An external clock (148.5 MHz) is needed when operating in this mode if display output is not in 1080p mode.

RECORD OUT AC TIMING

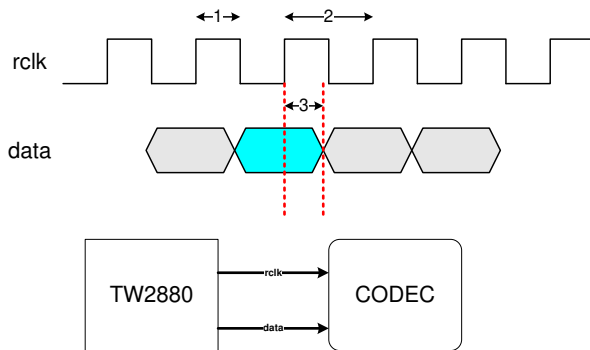

PARAMETER	SYMBOL	MIN	TYP	MAX	UNITS
Output Clock Half Period	1		4.62(108) 9.26 (54), 18.52 (27)		ns
Output Clock Period	2		9.25(108) 18.51 (54), 37.03 (27)		ns
Output Data Delay	3	2.6		5.2	ns

Register Table

Address	R/W	Default	Description
0xC00	R/W	0	Recording Buffer 1 Control Register A [7]: Reserved [6]: Recording format select [5:4]: Recording resolution select [3:0]: Channel Select
0xC01	R/W	0	Recording Buffer 2 Control Register A
0xC02	R/W	0	Recording Buffer 3 Control Register A
0xC03	R/W	0	Recording Buffer 4 Control Register A
0xC04	R/W	0	Recording Buffer 5 Control Register A
0xC05	R/W	0	Recording Buffer 6 Control Register A
0xC06	R/W	0	Recording Buffer 7 Control Register A
0xC07	R/W	0	Recording Buffer 8 Control Register A
0xC08	R/W	0	Recording Buffer 9 Control Register A
0xC09	R/W	0	Recording Buffer 10 Control Register A
0xC0A	R/W	0	Recording Buffer 11 Control Register A
0xC0B	R/W	0	Recording Buffer 12 Control Register A
0xC0C	R/W	0	Recording Buffer 13 Control Register A
0xC0D	R/W	0	Recording Buffer 14 Control Register A
0xC0E	R/W	0	Recording Buffer 15 Control Register A
0xC0F	R/W	0	Recording Buffer 16 Control Register A
0xC10	R/W	0	Recording Buffer 1 Control Register B [7]: Recording buffer enable [6:3]: Horizontal position select [2:0]: Vertical position select
0xC11	R/W	0	Recording Buffer 2 Control Register B
0xC12	R/W	0	Recording Buffer 3 Control Register B
0xC13	R/W	0	Recording Buffer 4 Control Register B
0xC14	R/W	0	Recording Buffer 5 Control Register B
0xC15	R/W	0	Recording Buffer 6 Control Register B
0xC16	R/W	0	Recording Buffer 7 Control Register B
0xC17	R/W	0	Recording Buffer 8 Control Register B
0xC18	R/W	0	Recording Buffer 9 Control Register B
0xC19	R/W	0	Recording Buffer 10 Control Register B
0xC1A	R/W	0	Recording Buffer 11 Control Register B
0xC1B	R/W	0	Recording Buffer 12 Control Register B
0xC1C	R/W	0	Recording Buffer 13 Control Register B
0xC1D	R/W	0	Recording Buffer 14 Control Register B
0xC1E	R/W	0	Recording Buffer 15 Control Register B
0xC1F	R/W	0	Recording Buffer 16 Control Register B
0xC20	R/W	0	Record Port 1 Control Register [7:6]: Output resolution select [5]: Output port format select [4]: Horizontal split read select [3]: Vertical split read select [2:1]: Output port clock select [0]: Output port buffer enable
0xC21	R/W	0	Record Port 1 Source Control Register A [7:4]: Source 1 buffer select [3:0]: Source 1 buffer select
0xC22	R/W	0	Record Port 1 Source Control Register B [7:4]: Source 3 buffer select [3:0]: Source 4 buffer select

Address	R/W	Default	Description
0xC23	R/W	0	Record Port 1 Custom Horizontal Control Register [7:0]: Value * 32 = HDE
0xC24	R/W	0	Record Port 1 Custom Vertical Control Register [7:0]: Value * 4 - 1 = VDE
0xC25	R/W	0	Record Port 2 Control Register [7:6]: Output resolution select [5]: Output port format select [4]: Horizontal split read select [3]: Vertical split read select [2:1]: Output port clock select [0]: Output port buffer enable
0xC26	R/W	0	Record Port 2 Source Control Register A [7:4]: Source 1 buffer select [3:0]: Source 1 buffer select
0xC27	R/W	0	Record Port 2 Source Control Register B [7:4]: Source 3 buffer select [3:0]: Source 4 buffer select
0xC28	R/W	0	Record Port 2 Custom Horizontal Control Register [7:0]: Value * 32 = HDE
0xC29	R/W	0	Record Port 2 Custom Vertical Control Register [7:0]: Value * 4 - 1 = VDE
0xC2A	R/W	0	Record Port 3 Control Register [7:6]: Output resolution select [5]: Output port format select [4]: Horizontal split read select [3]: Vertical split read select [2:1]: Output port clock select [0]: Output port buffer enable
0xC2B	R/W	0	Record Port 3 Source Control Register A [7:4]: Source 1 buffer select [3:0]: Source 1 buffer select
0xC2C	R/W	0	Record Port 3 Source Control Register B [7:4]: Source 3 buffer select [3:0]: Source 4 buffer select
0xC2D	R/W	0	Record Port 3 Custom Horizontal Control Register [7:0]: Value * 32 = HDE
0xC2E	R/W	0	Record Port 3 Custom Vertical Control Register [7:0]: Value * 4 - 1 = VDE
0xC2F	R/W	0	Record Port 4 Control Register [7:6]: Output resolution select [5]: Output port format select [4]: Horizontal split read select [3]: Vertical split read select [2:1]: Output port clock select [0]: Output port buffer enable
0xC30	R/W	0	Record Port 4 Source Control Register A [7:4]: Source 1 buffer select [3:0]: Source 1 buffer select
0xC31	R/W	0	Record Port 4 Source Control Register B [7:4]: Source 3 buffer select [3:0]: Source 4 buffer select
0xC32	R/W	0	Record Port 4 Custom Horizontal Control Register [7:0]: Value * 32 = HDE
0xC33	R/W	0	Record Port 4 Custom Vertical Control Register [7:0]: Value * 4 - 1 = VDE

Address	R/W	Default	Description
0xC34	R/W	0	Record Port 5 Control Register [7:6]: Output resolution select [5]: Output port format select [4:3]: Reserved [2:1]: Output port clock select [0]: Output port buffer enable
0xC35	R/W	0	Record port 5 Source Control Address Register[6:0]
0xC36	R/W	0	Record port 5 Source Control Data Register[4:0]
0xC37	R/W	0	Record port 5 Source Number Register[6:0]
0xC38	R/W	0	Record Port 5 Custom Horizontal Control Register [7:0]: Value * 32 = HDE
0xC39	R/W	0	Record Port 6 Custom Vertical Control Register [7:0]: Value * 4 - 1 = VDE
0xC3A	R/W	0	Record Port 6 Control Register [7:6]: Output resolution select [5]: Output port format select [4:3]: Reserved [2:1]: Output port clock select [0]: Output port buffer enable
0xC3B	R/W	0	Record port 6 Source Control Address Register[6:0]
0xC3C	R/W	0	Record port 6 Source Control Data Register[4:0]
0xC3D	R/W	0	Record port 6 Source Number Register[6:0]
0xC3E	R/W	0	Record Port 6 Custom Horizontal Control Register [7:0]: Value * 32 = HDE
0xC3F	R/W	0	Record Port 6 Custom Vertical Control Register [7:0]: Value * 4 - 1 = VDE
0xC40	R/W	0	Record Port 7 Control Register [7:6]: Output resolution select [5]: Output port format select [4:3]: Reserved [2:1]: Output port clock select [0]: Output port buffer enable
0xC41	R/W	0	Record port 7 Source Control Address Register[6:0]
0xC42	R/W	0	Record port 7 Source Control Data Register[4:0]
0xC43	R/W	0	Record port 7 Source Number Register[6:0]
0xC44	R/W	0	Record Port 7 Custom Horizontal Control Register [7:0]: Value * 32 = HDE
0xC45	R/W	0	Record Port 7 Custom Vertical Control Register [7:0]: Value * 4 - 1 = VDE
0xC46	R/W	0	Record Port 8 Control Register [7:6]: Output resolution select [5]: Output port format select [4:3]: Reserved [2:1]: Output port clock select [0]: Output port buffer enable
0xC47	R/W	0	Record port 8 Source Control Address Register[6:0]
0xC48	R/W	0	Record port 8 Source Control Data Register[4:0]
0xC49	R/W	0	Record port 8 Source Number Register[6:0]
0xC4A	R/W	0	Record Port 8 Custom Horizontal Control Register [7:0]: Value * 32 = HDE
0xC4B	R/W	0	Record Port 8 Custom Vertical Control Register [7:0]: Value * 4 - 1 = VDE

Address	R/W	Default	Description
0xC4C	R/W	0	Record Port 1-4 Source Number Register [7:6]: Number of source in port 4 [5:4]: Number of source in port 3 [3:2]: Number of source in port 2 [1:0]: Number of source in port 1
0xC4D	R/W	0	Record Port Operating Mode Select Register [7] ADV[1] [6] ADV[0] [5] Automatic correction [4] BT1120 Select [3] Network Port Interlaced FMI [2] Record test pattern [1] NTSC_PAL [0] WIN_READ
0xC4E	R/W	0	Output Pin Set 1 Control Register [7:4] Source 1 select [3] Clock polarity [2] Port width select [1:0] Pin clock select
0xC4F	R/W	0	Output Pin Set 2 Control Register [7:4] Source 1 select [3] Clock polarity [2] Port width select [1:0] Pin clock select
0xC50	R/W	0	Output Pin Set 3 Control Register [7:4] Source 1 select [3] Clock polarity [2] Port width select [1:0] Pin clock select
0xC51	R/W	0	Output Pin Set 4 Control Register [7:4] Source 1 select [3] Clock polarity [2] Port width select [1:0] Pin clock select
0xC52	R/W	0	Network Port Control Register [7:6]: Output resolution select [5]: Output port format select [4:3]: Reserved [2:1]: Output port clock select [0]: Output port buffer enable
0xC53	R/W	0	Network Port Source Control Address Register[6:0]
0xC54	R/W	0	Network Port Source Control Data Register[4:0]
0xC55	R/W	0	Network Port Source Number Register[6:0]
0xC56	R/W	0	MISC. Control 1 Register
0xC57	R/W	0	HMARGIN[7:0] Register
0xC58	R/W	0	MISC. Control 2 Register
0xC59	R/W	0	MISC. Control 3 Register
0xC5A	R/W	0	HDE selection
0xC5B	R/W	0	VDE selection
0xC5C	R/W	0	MISC. Control 4 Register
0xC64	R/W	0	Record Buffer Freeze Control Register A
0xC65	R/W	0	Record Buffer Freeze Control Register B
0xC66	R/W	0	SPOT Buffer Freeze Control Register A
0xC67	R/W	0	SPOT Buffer Freeze Control Register B

Address	R/W	Default	Description
0xC68	R/W	0	Custom Clock Control Register
0xC69	R/W	0	Interlaced FMI Control Register[7:0]
0xC6A	R/W	0	'wr_page' Reference Selection Control Register A(Write Buffer Index)
0xC6B	R/W	0	'wr_page' Reference Selection Control Register B(Read Port Index)
0xC6C	R/W	0	New FRSC control register
0xC90	R/W	0	SPOT Recording Buffer 1 Control Register A [7]: Reserved [6]: Recording format select [5:4]: Recording resolution select [3:0]: Channel Select
0xC91	R/W	0	SPOT Recording Buffer 2 Control Register A
0xC92	R/W	0	SPOT Recording Buffer 3 Control Register A
0xC93	R/W	0	SPOT Recording Buffer 4 Control Register A
0xC94	R/W	0	SPOT Recording Buffer 5 Control Register A
0xC95	R/W	0	SPOT Recording Buffer 6 Control Register A
0xC96	R/W	0	SPOT Recording Buffer 7 Control Register A
0xC97	R/W	0	SPOT Recording Buffer 8 Control Register A
0xC98	R/W	0	SPOT Recording Buffer 9 Control Register A
0xC99	R/W	0	SPOT Recording Buffer 10 Control Register A
0xC9A	R/W	0	SPOT Recording Buffer 11 Control Register A
0xC9B	R/W	0	SPOT Recording Buffer 12 Control Register A
0xC9C	R/W	0	SPOT Recording Buffer 13 Control Register A
0xC9D	R/W	0	SPOT Recording Buffer 14 Control Register A
0xC9E	R/W	0	SPOT Recording Buffer 15 Control Register A
0xC9F	R/W	0	SPOT Recording Buffer 16 Control Register A
0xCA0	R/W	0	SPOT Recording Buffer 1 Control Register B [7]: Recording buffer enable [6:3]: Horizontal position select [2:0]: Vertical position select
0xCA1	R/W	0	SPOT Recording Buffer 2 Control Register B
0xCA2	R/W	0	SPOT Recording Buffer 3 Control Register B
0xCA3	R/W	0	SPOT Recording Buffer 4 Control Register B
0xCA4	R/W	0	SPOT Recording Buffer 5 Control Register B
0xCA5	R/W	0	SPOT Recording Buffer 6 Control Register B
0xCA6	R/W	0	SPOT Recording Buffer 7 Control Register B
0xCA7	R/W	0	SPOT Recording Buffer 8 Control Register B
0xCA8	R/W	0	SPOT Recording Buffer 9 Control Register B
0xCA9	R/W	0	SPOT Recording Buffer 10 Control Register B
0xCAA	R/W	0	SPOT Recording Buffer 11 Control Register B
0xCAB	R/W	0	SPOT Recording Buffer 12 Control Register B
0xCAC	R/W	0	SPOT Recording Buffer 13 Control Register B
0xCAD	R/W	0	SPOT Recording Buffer 14 Control Register B
0xCAE	R/W	0	SPOT Recording Buffer 15 Control Register B
0xCAF	R/W	0	SPOT Recording Buffer 16 Control Register B
0xCC8	R/W	0	Background Buffer Indication Register 1
0xCC9	R/W	0	Background Buffer Indication Register 2
0xCCA	R/W	0	Second Record DRAM Buffer Register 1
0xCCB	R/W	0	Second Record DRAM Buffer Register 2
0xCCC	R/W	0	Second SPOT DRAM Buffer Register 1
0xCCD	R/W	0	Second SPOT DRAM Buffer Register 2
0xCCE	R/W	0	Record Buffer Alternate Source Register 1
0xCCF	R/W	0	Record Buffer Alternate Source Register 2
0xCDO	R/W	0	Record Buffer Horizontal Offset Control Register 1

Address	R/W	Default	Description
0xCD1	R/W	0	Record Buffer Horizontal Offset Control Register 2
0xCD2	R/W	0	Record Buffer Horizontal Offset Control Register 3
0xCD3	R/W	0	Record Buffer Horizontal Offset Control Register 4
0xCD4	R/W	0	Record Buffer Horizontal Offset Control Register 5
0xCD5	R/W	0	Record Buffer Horizontal Offset Control Register 6
0xCD6	R/W	0	Record Buffer Horizontal Offset Control Register 7
0xCD7	R/W	0	Record Buffer Horizontal Offset Control Register 8
0xCD8	R/W	0	Record Buffer Horizontal Offset Control Register 9
0xCD9	R/W	0	Record Buffer Horizontal Offset Control Register 10
0xCDA	R/W	0	Record Buffer Horizontal Offset Control Register 11
0xCDB	R/W	0	Record Buffer Horizontal Offset Control Register 12
0xCDC	R/W	0	Record Buffer Horizontal Offset Control Register 13
0xCDD	R/W	0	Record Buffer Horizontal Offset Control Register 14
0xCDE	R/W	0	Record Buffer Horizontal Offset Control Register 15
0xCDF	R/W	0	Record Buffer Horizontal Offset Control Register 16
0xCE0	R/W	0	Record Buffer Vertical Offset Control Register 1
0xCE1	R/W	0	Record Buffer Vertical Offset Control Register 2
0xCE2	R/W	0	Record Buffer Vertical Offset Control Register 3
0xCE3	R/W	0	Record Buffer Vertical Offset Control Register 4
0xCE4	R/W	0	Record Buffer Vertical Offset Control Register 5
0xCE5	R/W	0	Record Buffer Vertical Offset Control Register 6
0xCE6	R/W	0	Record Buffer Vertical Offset Control Register 7
0xCE7	R/W	0	Record Buffer Vertical Offset Control Register 8
0xCE8	R/W	0	Record Buffer Vertical Offset Control Register 9
0xCE9	R/W	0	Record Buffer Vertical Offset Control Register 10
0xCEA	R/W	0	Record Buffer Vertical Offset Control Register 11
0xCEB	R/W	0	Record Buffer Vertical Offset Control Register 12
0xCEC	R/W	0	Record Buffer Vertical Offset Control Register 13
0xCED	R/W	0	Record Buffer Vertical Offset Control Register 14
0CEE	R/W	0	Record Buffer Vertical Offset Control Register 15
0CEF	R/W	0	Record Buffer Vertical Offset Control Register 16
0xCF0	R/W	0	Special Component Record mode Register
0xCF1	R/W	0	Record Buffer Field Switching Record Mode Register 1
0xCF2	R/W	0	Record Buffer Field Switching Record Mode Register 2
0xCF3	R/W	0	Record Buffer Field Switching Record Mode Field Select Register 1
0xCF4	R/W	0	Record Buffer Field Switching Record Mode Field Select Register 2
0xCF5	R/W	0	Output Pin Set Source 2 Control Register A
0xCF6	R/W	0	Output Pin Set Source 2 Control Register B
0xCF7	R/W	0	Frame Rate Controller Update Register
0xCF8	R/W	0	SPOT Buffer Field Switching Record Mode Register 1
0xCF9	R/W	0	SPOT Buffer Field Switching Record Mode Register 2
0xCFA	R/W	0	SPOT Buffer Field Switching Record Mode Field Select Register 1
0xCFB	R/W	0	SPOT Buffer Field Switching Record Mode Field Select Register 2
0xCFC	R/W	0	Write Buffer Control Register
0xCFD	R/W	0	New FRSC Control Register
0xCFE	R/W	0	New Write Buffer Mapping Control Register

Registers Description

RECORDING BUFFER 1 CONTROL REGISTER A – 0XC00

Bit	R/W	Default	Description
7	R	0x0	Reserved
6	R/W	0x0	Recording Format Select 0 = Frame Interleaved 1 = Field Interleaved
5:4	R/W	0x0	Recording Resolution Select 00 = D1 01 = Half D1 10 = CIF 11 = Reserved
3:0	R/W	0x0	Incoming Channel Select [3:0] = Channel being recorded

RECORDING BUFFER 1 CONTROL REGISTER B – 0XC10

Bit	R/W	Default	Description
7	R/W	0x0	Recording Buffer Enable 0 = Disable (default) 1 = Enable
6:3	R/W	0x0	Horizontal Position Select 0000 = 0 0001 = 320 (6VGA), 360 0010 = 640 (6VGA), 720 0011 = 960 (6VGA), 1080 0100 = 1280 (6VGA), 1440 0101 = 1600 (6VGA), 1800 0110 = 1920 (6VGA), 2160 0111 = 2240 (6VGA), 2520 Other = reserved
2:0	R/W	0x0	Vertical Position Select 000 = 0 001 = 135 (6VGA), 144 (PAL), 120 (NTSC) 010 = 270 (6VGA), 288 (PAL), 240 (NTSC) 011 = 405 (6VGA), 432 (PAL), 360 (NTSC) 100 = 540 (6VGA), 576 (PAL), 480 (NTSC) 101 = 675 (6VGA), 720 (PAL), 600 (NTSC) 110 = 810 (6VGA), 864 (PAL), 720 (NTSC) 111 = 945 (6VGA), 1008 (PAL), 840 (NTSC)

Similar assignments to other buffers (2-16) follow: 0xC01 - 0xC0F Recording buffer Control Register A. 0xC11 - 0xC1F Recording buffer Control Register B.

RECORD PORT 1 CONTROL REGISTER – 0XC20

Bit	R/W	Default	Description
7:6	R/W	0x0	Output Resolution Select 00 = D1 01 = CIF (short burst special format) 10 = 4D1 (special format) 11 = BT.1120 (1080)
5	R/W	0x0	Output Port Format Select 0 = Frame Interleaved 1 = Field Interleaved
4	R/W	0x0	Horizontal Split Read Select 0 = disable 1 = enable
3	R/W	0x0	Vertical Split Read Select 0 = disable 1 = enable
2:1	R/W	0x0	Output Port Clock Select 00 = ¼ of record clock 01 = ½ of record clock 10 = full record clock 11 = Reserved
0	R/W	0x0	Output Port Buffer Enable 0 = Disable 1 = Enable record out function

RECORD PORT 1 SOURCE CONTROL REGISTER A – 0XC21

Bit	R/W	Default	Description
7:4	R/W	0x0	Source 1 Buffer Select
3:0	R/W	0x0	Source 2 Buffer Select

RECORD PORT 1 SOURCE CONTROL REGISTER B – 0XC22

Bit	R/W	Default	Description
7:4	R/W	0x0	Source 3 Buffer Select
3:0	R/W	0x0	Source 4 Buffer Select

RECORD PORT 1 CUSTOM HORIZONTAL CONTROL REGISTER – 0XC23

Bit	R/W	Default	Description
7:0	R/W	0x0	HDE[7:0] Times 16

RECORD PORT 1 CUSTOM VERTICAL CONTROL REGISTER – 0XC24

Bit	R/W	Default	Description
7:0	R/W	0x0	VDE[7:0] Times 4

RECORD PORT 2 CONTROL REGISTER – 0XC25

Bit	R/W	Default	Description
7:6	R/W	0x0	Output Resolution Select 00 = D1 01 = CIF (short burst special format) 10 = 4D1 (special format) 11 = BT.1120 (1080)
5	R/W	0x0	Output Port Format Select 0 = Frame Interleaved 1 = Field Interleaved
4	R/W	0x0	Horizontal Split Read Select 0 = disable 1 = enable
3	R/W	0x0	Vertical Split Read Select 0 = disable 1 = enable
2:1	R/W	0x0	Output Port Clock Select 00 = ¼ of record clock 01 = ½ of record clock 10 = full record clock 11 = Reserved
0	R/W	0x0	Output Port Buffer Enable 0 = Disable 1 = Enable record out function

RECORD PORT 2 SOURCE CONTROL REGISTER A – 0XC26

Bit	R/W	Default	Description
7:4	R/W	0x0	Source 1 Buffer Select
3:0	R/W	0x0	Source 2 Buffer Select

RECORD PORT 2 SOURCE CONTROL REGISTER B – 0XC27

Bit	R/W	Default	Description
7:4	R/W	0x0	Source 3 Buffer Select
3:0	R/W	0x0	Source 4 Buffer Select

RECORD PORT 2 CUSTOM HORIZONTAL CONTROL REGISTER – 0XC28

Bit	R/W	Default	Description
7:0	R/W	0x0	HDE[7:0] Times 16

RECORD PORT 2 CUSTOM VERTICAL CONTROL REGISTER – 0XC29

Bit	R/W	Default	Description
7:0	R/W	0x0	VDE[7:0] Times 4

RECORD PORT 3 CONTROL REGISTER – 0XC2A

Bit	R/W	Default	Description
7:6	R/W	0x0	Output Resolution Select 00 = D1 01 = CIF (short burst special format) 10 = 4D1 (special format) 11 = BT.1120 (1080)
5	R/W	0x0	Output Port Format Select 0 = Frame Interleaved 1 = Field Interleaved
4	R/W	0x0	Horizontal Split Read Select 0 = disable 1 = enable
3	R/W	0x0	Vertical Split Read Select 0 = disable 1 = enable
2:1	R/W	0x0	Output Port Clock Select 00 = ¼ of record clock 01 = ½ of record clock 10 = full record clock 11 = Reserved
0	R/W	0x0	Output Port Buffer Enable 0 = Disable 1 = Enable record out function

RECORD PORT 3 SOURCE CONTROL REGISTER A – 0XC2B

Bit	R/W	Default	Description
7:4	R/W	0x0	Source 1 Buffer Select
3:0	R/W	0x0	Source 2 Buffer Select

RECORD PORT 3 SOURCE CONTROL REGISTER B – 0XC2C

Bit	R/W	Default	Description
7:4	R/W	0x0	Source 3 Buffer Select
3:0	R/W	0x0	Source 4 Buffer Select

RECORD PORT 3 CUSTOM HORIZONTAL CONTROL REGISTER – 0XC2D

Bit	R/W	Default	Description
7:0	R/W	0x0	HDE[7:0] Times 16

RECORD PORT 3 CUSTOM VERTICAL CONTROL REGISTER – 0XC2E

Bit	R/W	Default	Description
7:0	R/W	0x0	VDE[7:0] Times 4

RECORD PORT 4 CONTROL REGISTER – 0XC2F

Bit	R/W	Default	Description
7:6	R/W	0x0	Output Resolution Select 00 = D1 01 = CIF (short burst special format) 10 = 4D1 (special format) 11 = BT.1120 (1080)
5	R/W	0x0	Output Port Format Select 0 = Frame Interleaved 1 = Field Interleaved
4	R/W	0x0	Horizontal Split Read Select 0 = disable 1 = enable
3	R/W	0x0	Vertical Split Read Select 0 = disable 1 = enable
2:1	R/W	0x0	Output Port Clock Select 00 = ¼ of record clock 01 = ½ of record clock 10 = full record clock 11 = Reserved
0	R/W	0x0	Output Port Buffer Enable 0 = Disable 1 = Enable record out function

RECORD PORT 4 SOURCE CONTROL REGISTER A – 0XC30

Bit	R/W	Default	Description
7:4	R/W	0x0	Source 1 Buffer Select
3:0	R/W	0x0	Source 2 Buffer Select

RECORD PORT 4 SOURCE CONTROL REGISTER B – 0XC31

Bit	R/W	Default	Description
7:4	R/W	0x0	Source 3 Buffer Select
3:0	R/W	0x0	Source 4 Buffer Select

RECORD PORT 4 CUSTOM HORIZONTAL CONTROL REGISTER – 0XC32

Bit	R/W	Default	Description
7:0	R/W	0x0	HDE[7:0] Times 16

RECORD PORT 4 CUSTOM VERTICAL CONTROL REGISTER – 0XC33

Bit	R/W	Default	Description
7:0	R/W	0x0	VDE[7:0] Times 4

RECORD PORT 5 CONTROL REGISTER – 0XC34

Bit	R/W	Default	Description
7:6	R/W	0x0	Output Resolution Select 00 = D1 01 = CIF (short burst special format) 10 = 4D1 (special format) 11 = BT.1120 (1080)
5	R/W	0x0	Output Port Format Select 0 = Frame Interleaved 1 = Field Interleaved
4:3	R/W	0x0	Reserved
2:1	R/W	0x0	Output Port Clock Select 00 = ¼ of record clock 01 = ½ of record clock 10 = full record clock 11 = Reserved
0	R/W	0x0	Output Port Buffer Enable 0 = Disable 1 = Enable record out function

RECORD PORT 5 SOURCE CONTROL ADDRESS REGISTER – 0XC35

Bit	R/W	Default	Description
7	R	0x0	Reserved
6:0	R/W	0x0	Address in Source RAM

RECORD PORT 5 SOURCE CONTROL DATA REGISTER – 0XC36

Bit	R/W	Default	Description
7:6	R	0x0	Reserved
5	R/W	0x0	Write 1 to trigger Double Buffer Update
4:0	R/W	0x0	Source Buffer Select (32)

RECORD PORT 5 SOURCE NUMBER REGISTER – 0XC37

Bit	R/W	Default	Description
7	R/W	0x0	Reserved
6:0	R/W	0x0	Number of Source in the list (128 is the largest)

RECORD PORT 5 CUSTOM HORIZONTAL CONTROL REGISTER – 0XC38

Bit	R/W	Default	Description
7:0	R/W	0x0	HDE[7:0] Times 16

RECORD PORT 5 CUSTOM VERTICAL CONTROL REGISTER – 0XC39

Bit	R/W	Default	Description
7:0	R/W	0x0	VDE[7:0] Times 4

RECORD PORT 6 CONTROL REGISTER – 0XC3A

Bit	R/W	Default	Description
7	R/W	0x0	Output Resolution Select 00 = D1 01 = CIF (short burst special format) 10 = 4D1 (special format) 11 = BT.1120 (1080)
5	R/W	0x0	Output Port Format Select 0 = Frame Interleaved 1 = Field Interleaved
4:3	R/W	0x0	Reserved
2:1	R/W	0x0	Output Port Clock Select 00 = ¼ of record clock 01 = ½ of record clock 10 = full record clock 11 = Reserved
0	R/W	0x0	Output Port Buffer Enable 0 = Disable 1 = Enable record out function

RECORD PORT 6 SOURCE CONTROL ADDRESS REGISTER – 0XC3B

Bit	R/W	Default	Description
7	R	0x0	Reserved
6:0	R/W	0x0	Address in Source RAM

RECORD PORT 6 SOURCE CONTROL DATA REGISTER – 0XC3C

Bit	R/W	Default	Description
7:4	R/W	0x0	Reserved
5	R/W	0x0	Write 1 to trigger Double Buffer Update
4:0	R/W	0x0	Source Buffer Select (32)

RECORD PORT 6 SOURCE NUMBER REGISTER – 0XC3D

Bit	R/W	Default	Description
7	R/W	0x0	Reserved
6:0	R/W	0x0	Number of Source in the list (128 is the largest)

RECORD PORT 6 CUSTOM HORIZONTAL CONTROL REGISTER – 0XC3E

Bit	R/W	Default	Description
7:0	R/W	0x0	HDE[7:0] Times 16

RECORD PORT 6 CUSTOM VERTICAL CONTROL REGISTER – 0XC3F

Bit	R/W	Default	Description
7:0	R/W	0x0	VDE[7:0] Times 4

RECORD PORT 7 CONTROL REGISTER – 0XC40

Bit	R/W	Default	Description
7:6	R/W	0x0	Output Resolution Select 00 = D1 01 = CIF (short burst special format) 10 = 4D1 (special format) 11 = BT.1120 (1080)
5	R/W	0x0	Output Port Format Select 0 = Frame Interleaved 1 = Field Interleaved
4:3	R/W	0x0	Reserved
2:1	R/W	0x0	Output Port Clock Select 00 = ¼ of record clock 01 = ½ of record clock 10 = full record clock 11 = Reserved
0	R/W	0x0	Output Port Buffer Enable 0 = Disable 1 = Enable record out function

RECORD PORT 7 SOURCE CONTROL ADDRESS REGISTER – 0XC41

Bit	R/W	Default	Description
7	R	0x0	Reserved
6:0	R/W	0x0	Address in Source RAM

RECORD PORT 7 SOURCE CONTROL DATA REGISTER – 0XC42

Bit	R/W	Default	Description
7:4	R/W	0x0	Reserved
5	R/W	0x0	Write 1 to trigger Double Buffer Update
4:0	R/W	0x0	Source Buffer Select (32)

RECORD PORT 7 SOURCE NUMBER REGISTER – 0XC43

Bit	R/W	Default	Description
7	R/W	0x0	Reserved
6:0	R/W	0x0	Number of Source in the list (128 is the largest)

RECORD PORT 7 CUSTOM HORIZONTAL CONTROL REGISTER – 0XC44

Bit	R/W	Default	Description
7:0	R/W	0x0	HDE[7:0] Times 16

RECORD PORT 7 CUSTOM VERTICAL CONTROL REGISTER – 0XC45

Bit	R/W	Default	Description
7:0	R/W	0x0	VDE[7:0] Times 4

RECORD PORT 8 CONTROL REGISTER – 0XC46

Bit	R/W	Default	Description
7:6	R/W	0x0	Output Resolution Select 00 = D1 01 = CIF (short burst special format) 10 = 4D1 (special format) 11 = BT.1120 (1080)
5	R/W	0x0	Output Port Format Select 0 = Frame Interleaved 1 = Field Interleaved
4:3	R/W	0x0	Reserved
2:1	R/W	0x0	Output Port Clock Select 00 = ¼ of record clock 01 = ½ of record clock 10 = full record clock 11 = Reserved
0	R/W	0x0	Output Port Buffer Enable 0 = Disable 1 = Enable record out function

RECORD PORT 8 SOURCE CONTROL ADDRESS REGISTER – 0XC47

Bit	R/W	Default	Description
7	R	0x0	Reserved
6:0	R/W	0x0	Address in Source RAM

RECORD PORT 8 SOURCE CONTROL DATA REGISTER – 0XC48

Bit	R/W	Default	Description
7:6	R/W	0x0	Reserved
5	R/W	0x0	Write 1 to trigger Double Buffer Update
4:0	R/W	0x0	Source Buffer Select (32)

RECORD PORT 8 SOURCE NUMBER REGISTER – 0XC49

Bit	R/W	Default	Description
7	R/W	0x0	Reserved
6:0	R/W	0x0	Number of Source in the list (128 is the largest)

RECORD PORT 8 CUSTOM HORIZONTAL CONTROL REGISTER – 0XC4A

Bit	R/W	Default	Description
7:0	R/W	0x0	HDE[7:0] Times 16

RECORD PORT 8 CUSTOM VERTICAL CONTROL REGISTER – 0XC4B

Bit	R/W	Default	Description
7:0	R/W	0x0	VDE[7:0] Times 4

RECORD PORT 1-4 SOURCE CONTROL REGISTER – 0XC4C

Bit	R/W	Default	Description
7:6	R/W	0x0	Number of Source in the port 4 list (4 is the largest)
5:4	R/W	0x0	Number of Source in the port 3 list (4 is the largest)
3:2	R/W	0x0	Number of Source in the port 2 list (4 is the largest)
1:0	R/W	0x0	Number of Source in the port 1 list (4 is the largest)

RECORD PORT OPERATING MODE SELECT REGISTER – 0XC4D

Bit	R/W	Default	Description
7	R/W	0x0	Bottom field low speed update algorithm select 1 = 54 /27 MHz, 0 = normal ADV[1]
6	R/W	0x0	Top field low speed update algorithm select 1 = 54 /27 MHz, 0 = normal ADV[0]
5	R/W	0x0	Enable field mode automatic correction 0 = disable (default) 1 = enable
4	R/W	0x0	BT.1120 PAL 50 /60 Hz Selection 0 = 50 Hz (default) 1 = 60 Hz
3	R/W	0x0	Network port Interlaced FMI Mode Control 0 = Normal (default) 1 = Turn on
2	R/W	0x0	Record Source Select 0 = Live mode (default) 1 = Internal test pattern mode
1	R/W	0x0	Record Standard Select 0 = NTSC mode (default) 1 = PAL mode
0	R/W	0x0	Limit Motion Circuitry Read / Write Activity 0 = Disable (default) 1 = Enable

OUTPUT PIN SET 1 CONTROL REGISTER – 0XC4E

Bit	R/W	Default	Description
7:4	R/W	0x0	Source 1 Select[3:0] 1111 = port 8 output high byte 1110 = port 8 output low byte 1101 = port 7 output high byte 1100 = port 7 output low byte 1011 = port 6 output high byte 1010 = port 6 output low byte 1001 = port 5 output high byte 1000 = port 5 output low byte 0111 = port 4 output high byte 0110 = port 4 output low byte 0101 = port 3 output high byte 0100 = port 3 output low byte 0011 = port 2 output high byte 0010 = port 2 output low byte 0001 = port 1 output high byte 0000 = port 1 output low byte (default)
3	R/W	0x0	Clock Polarity Select 0 = normal, 1 = inverted
2	R/W	0x0	Port width Select 0 = 8 bit, 1 = 16 bit
1:0	R/W	0x0	Pin Clock Select 00 = ¼ of record clock 01 = ½ of record clock 10 = full record clock 11 = ½ of the external clock, input from ball AC5

OUTPUT PIN SET 2 CONTROL REGISTER – 0XC4F

Bit	R/W	Default	Description
7:4	R/W	0x0	Source 1 Select[3:0] 1111 = port 8 output high byte 1110 = port 8 output low byte 1101 = port 7 output high byte 1100 = port 7 output low byte 1011 = port 6 output high byte 1010 = port 6 output low byte 1001 = port 5 output high byte 1000 = port 5 output low byte 0111 = port 4 output high byte 0110 = port 4 output low byte 0101 = port 3 output high byte 0100 = port 3 output low byte (default) 0011 = port 2 output high byte 0010 = port 2 output low byte 0001 = port 1 output high byte 0000 = port 1 output low byte

Bit	R/W	Default	Description
3	R/W	0x0	Clock Polarity Select 0 = normal, 1 = inverted
2	R/W	0x0	Port width Select 0 = 8 bit, 1 = 16 bit
1:0	R/W	0x0	Pin Clock Select 00 = ¼ of record clock 01 = ½ of record clock 10 = full record clock 11 = ½ of the external clock, input from ball AC5

OUTPUT PIN SET 3 CONTROL REGISTER – 0XC50

Bit	R/W	Default	Description
7	R/W	0x0	Source 1 Select[3:0] 1111 = port 8 output high byte 1110 = port 8 output low byte 1101 = port 7 output high byte 1100 = port 7 output low byte 1011 = port 6 output high byte 1010 = port 6 output low byte 1001 = port 5 output high byte 1000 = port 5 output low byte (default) 0111 = port 4 output high byte 0110 = port 4 output low byte 0101 = port 3 output high byte 0100 = port 3 output low byte 0011 = port 2 output high byte 0010 = port 2 output low byte 0001 = port 1 output high byte 0000 = port 1 output low byte
3	R/W	0x0	Clock Polarity Select 0 = normal, 1 = inverted
2	R/W	0x0	Port width Select 0 = 8 bit, 1 = 16 bit
1:0	R/W	0x0	Pin Clock Select 00 = ¼ of record clock 01 = ½ of record clock 10 = full record clock 11 = ½ of the external clock, input from ball AC5

OUTPUT PIN SET 4 CONTROL REGISTER – 0XC51

Bit	R/W	Default	Description
7	R/W	0x0	Source 1 Select[3:0] 1111 = port 8 output high byte 1110 = port 8 output low byte 1101 = port 7 output high byte 1100 = port 7 output low byte (default) 1011 = port 6 output high byte 1010 = port 6 output low byte 1001 = port 5 output high byte 1000 = port 5 output low byte 0111 = port 4 output high byte 0110 = port 4 output low byte 0101 = port 3 output high byte 0100 = port 3 output low byte 0011 = port 2 output high byte 0010 = port 2 output low byte 0001 = port 1 output high byte 0000 = port 1 output low byte
3	R/W	0x0	Clock Polarity Select 0 = normal, 1 = inverted
2	R/W	0x0	Port width Select 0 = 8 bit, 1 = 16 bit
1:0	R/W	0x0	Pin Clock Select 00 = ¼ of record clock 01 = ½ of record clock 10 = full record clock 11 = ½ of the external clock, input from ball AC5

NETWORK PORT CONTROL REGISTER – 0XC52

Bit	R/W	Default	Description
7:6	R/W	0x0	Output Resolution Select 00 = D1 01 = CIF (short burst special format) 10 = 4D1 (special format) 11 = BT.1120 (1080)
5	R/W	0x0	Output Port Format Select 0 = Frame Interleaved 1 = Field Interleaved
4:3	R/W	0x0	Reserved
2:1	R/W	0x0	Output Port Clock Select 00 = ¼ of record clock 01 = ½ of record clock 10 = full record clock 11 = Reserved

Bit	R/W	Default	Description
0	R/W	0x0	Output Port Buffer Enable 0 = Disable 1 = Enable record out function

NETWORK PORT CONTROL ADDRESS REGISTER – 0XC53

Bit	R/W	Default	Description
7	R	0x0	Reserved
6:0	R/W	0x0	Address In Source RAM

NETWORK PORT CONTROL DATA REGISTER – 0XC54

Bit	R/W	Default	Description
7:6	R/W	0x0	Reserved
6	R/W	0x0	Write 1 to trigger Double Buffer Update
5:0	R/W	0x0	Source Buffer Select (48)

NETWORK PORT SOURCE NUMBER REGISTER – 0XC55

Bit	R/W	Default	Description
7	R/W	0x0	Enable Free Running Network Port 1 = enable, 0 = normal mode
6:0	R/W	0x0	Number of Source in the list (128 is the largest)

MISC. CONTROL REGISTER 1 – 0XC56

Bit	R/W	Default	Description
7	R/W	0x0	SPREAD Spread read sync option 1 = spread read syn, 0 = no spread
6	R/W	0x0	RST_SEL Select different MCLK reset width in FIFO 1 = Different reset, 0 = Same reset
5	R/W	0x0	Bottom field low speed update algorithm select 1 = 54 /27 MHz, 0 = normal ADV[1] for SPOT
4	R/W	0x0	Top field low speed update algorithm select 1 = 54 /27 MHz, 0 = normal ADV[0] for SPOT
3	R/W	0x0	Horizontal Control Override in 6 VGA mode
2:0	R/W	0x0	Select record side FRSC source

4D1 AND QUAD 2ND WRITE HORIZONTAL MARGIN REGISTER – 0XC57

Bit	R/W	Default	Description
7:0	R/W	0x0	HMARGIN[7:0] Unit is hcnt. Increase the 2 nd write hblank by this number

MISC. CONTROL REGISTER 2 – 0XC58

Bit	R/W	Default	Description
7	R/W	0x0	1 = Limit Record unit start time if using SPOT buffers 1 = disable (default) 0 = enable
6	R/W	0x0	1 = Limit Record unit start time if using record buffers 1 = disable (default) 0 = enable
5:4	R/W	0x0	Record Write Buffer Request Level Control (default = 1)
3:0	R/W	0x0	Enable no_video reset frame rate control unit Bit 0: ROUT1 – ROUT4 Bit 1: ROUT5 – ROUT6 Bit 2: ROUT7 – ROUT8 Bit 3: ROUT9

MISC. CONTROL REGISTER 3 – 0XC59

Bit	R/W	Default	Description
7:6	R/W	0x0	SPOT Write Buffer Request Level Control (default = 1)
5	R/W	0x0	SPOT Buffer Vertical Invert Line Number Option
4	R/W	0x0	Record Buffer Vertical Invert Line Number Option
3:2	R/W	0x0	SPOT Buffer Update Option Select
1:0	R/W	0x0	Record Buffer Update Option Select

RECORD HDE CONTROL REGISTER – 0XC5A

Bit	R/W	Default	Description
7:0	R/W	0x0	HDE selection

RECORD VDE CONTROL REGISTER – 0XC5B

Bit	R/W	Default	Description
7:0	R/W	0x0	VDE selection

RECORD BUFFER FREEZE CONTROL REGISTER A – 0XC64

Bit	R/W	Default	Description
7:0	R/W	0x0	Freeze Control [7:0] 1 = Channel Freeze 0 = Normal

RECORD BUFFER FREEZE CONTROL REGISTER B – 0XC65

Bit	R/W	Default	Description
7:0	R/W	0x0	Freeze Control [15:8] 1 = Channel Freeze 0 = Normal

SPOT BUFFER FREEZE CONTROL REGISTER A – 0XC66

Bit	R/W	Default	Description
7:0	R/W	0x0	Freeze Control [7:0] 1 = Channel Freeze 0 = Normal

SPOT BUFFER FREEZE CONTROL REGISTER B – 0XC67

Bit	R/W	Default	Description
7:0	R/W	0x0	Freeze Control [15:8] 1 = Channel Freeze 0 = Normal

CUSTOM CLOCK CONTROL REGISTER – 0XC68

Bit	R/W	Default	Description
7	R/W	0x0	Window Position Shadow Register Select 0 = recording, 1= SPOT
6:2	R	0x0	Reserved
1:0	R/W	0x0	Custom Clock Source Select 00 = Select system clock (108 MHz) 01 = Select Internal video clock (vck1), see AP note1 p8 10 = Select Internal video clock (vck), see AP note1 p8 11 = Select external clock source

INTERLACED FRAME OUTPUT MODE CONTROL REGISTER – 0XC69

Bit	R/W	Default	Description
7:0	R/W	0x0	Interlaced Frame Control Port 8 to Port1 0 = Progressive Frame (default) 1 = Interlaced Frame

'WR_PAGE' REFERENCE SELECTION CONTROL REGISTER A(WRITE BUFFER INDEX) – 0XC6A

Bit	R/W	Default	Description
7:6	R	0x0	Reserved
5:0	R/W	0x0	WR_BUF_ADDR wr_buffer index for selecting 'wr_page' reference from read port 0 ~ 15 : recording write buffer 0 ~ 15 16 ~ 31 : SPOT write buffer 0 ~ 15

'WR_PAGE' REFERENCE SELECTION CONTROL REGISTER B(READ PORT INDEX) – 0XC6B

Bit	R/W	Default	Description
7:6	R	0x0	Reserved
5	R/W	0x0	BANK_SEL_SEP 0 = Use one 'bank_sel' signal for each port 1 = Use separated several 'bank_sel' signals for each port
4	R/W	0x0	WR_PAGE_SEP 0 = Use one wr_page reference 1 = Use separated wr_page reference according to the write buffer
3:0	R/W	0x0	wr_page_sel wr_page reference selection value 0 = port1 wr_page reference 1 = port2 wr_page reference 2 = port3 wr_page reference 3 = port4 wr_page reference 4 = port5 wr_page reference 5 = port6 wr_page reference 6 = port7 wr_page reference 7 = port8 wr_page reference 8 = network port wr_page reference 9 = SPOT1 wr_page reference 10 = SPOT2 wr_page reference 11 = SPOT3 wr_page reference 12 = SPOT4 wr_page reference the others = port1 wr_page reference

NEW FRSC CONTROL REGISTER B – 0XC6C

Bit	R/W	Default	Description
7	R/W	0x0	FLD_BANK_INC Bank increase option in the non-real time field mode 0 = Bank is increased in every number of channel 1 = Bank is increased in every frame rate
6	R/W	0x0	FLD_HVCNT_SEL Field generation option in the hvcnt_rout 0 = Old one 1 = New one
5	R/W	0x0	FLD_CCIR_SEL Field generation option in the ccir_out_fmt 0 = Old one 1 = New one
4	R/W	0x0	WR_BUF_FLI_STOP Write buffer stop control selection between frame and field stop 0 = Frame stop 1 = Field stop
3	R/W	0x0	WR_BUF_STOP Read bank repeat option when write buffer is stop in the 4-frame field mode 0 = Repeat one field 1 = Repeat one frame

Bit	R/W	Default	Description
2	R/W	0x0	FLI_RD_STOP Read bank repeat option when bank stop condition is occurred in the 4-frame field mode 0 = Repeat one field 1 = Repeat one frame
1	R/W	0x0	FLI_RD Field interleaved read mode with 4 frames 0 = 2 frames 1 = 4 frames
0	R/W	0x0	RD_FRSC_FLI_EN Read side frame rate control enable for field mode 0 = Original frame rate control(bank is increased without checking relation between read and write bank values) 1 = New frame rate control in read side(bank is increased if some condition is met between read and write bank values)

PB IGNORE BIT CONTROL REGISTER – 0XC6D

Bit	R/W	Default	Description
7:0	R/W	0x0	PB_IGNORE PB ignore bit on/off control for each port1 ~ port8 0 = Ignore bit disable 1 = Ignore bit enable

PB IGNORE VALUE REGISTER 1 – 0XC6E

Bit	R/W	Default	Description
7:4	R/W	0x0	PB_IG_DATA1 2 nd PB ignore bit value
3:0	R/W	0x0	PB_IG_DATA0 1 st PB ignore bit value

PB IGNORE VALUE REGISTER 2 – 0XC6F

Bit	R/W	Default	Description
7:4	R/W	0x0	PB_IG_DATA3 4 th PB ignore bit value
3:0	R/W	0x0	PB_IG_DATA2 3 rd PB ignore bit value

BACKGROUND COLOR FOR CB – 0XC70

Bit	R/W	Default	Description
7:0	R/W	0x0	BG_CB Background color of Cb

BACKGROUND COLOR FOR CR – 0XC71

Bit	R/W	Default	Description
7:0	R/W	0x0	BG_CR Background color of Cr

BACKGROUND COLOR FOR Y – 0XC72

Bit	R/W	Default	Description
7:0	R/W	0x0	BG_Y Background color of Y

BACKGROUND ON/OFF CONTROL 1 FOR RECORD WRITE BUFFER – 0XC73

Bit	R/W	Default	Description
7:0	R/W	0x0	BG_ON_REC[7:0] Background on/off control for record write buffer 1 ~ buffer 8

BACKGROUND ON/OFF CONTROL 2 FOR RECORD WRITE BUFFER – 0XC74

Bit	R/W	Default	Description
7:0	R/W	0x0	BG_ON_REC[15:8] Background on/off control for record write buffer 9 ~ buffer 16

BACKGROUND ON/OFF CONTROL 1 FOR SPOT WRITE BUFFER – 0XC75

Bit	R/W	Default	Description
7:0	R/W	0x0	BG_ON_SPOT[7:0] Background on/off control for SPOT write buffer 1 ~ buffer 8

BACKGROUND ON/OFF CONTROL 2 FOR SPOT WRITE BUFFER – 0XC76

Bit	R/W	Default	Description
7:0	R/W	0x0	BG_ON_SPOT[15:8] Background on/off control for SPOT write buffer 9 ~ buffer 16

NEW NON-REAL TIME FIELD SWITCHING MODE FOR PORT 5 ~ PORT 9 – 0XC77

Bit	R/W	Default	Description
7:5	R/W	0x0	Reserved
4:0	R/W	0x0	NEW_FLI_SW New field switching mode for non-real time 0 = Original 1 = New field switching

NEW FIELD SWITCHING MODE FIELD SELECT FOR PORT 5 - PORT 9 - 0XC78

Bit	R/W	Default	Description
7:5	R/W	0x0	Reserved
4:0	R/W	0x0	NEW_FLI_SW_SEL Field selection for new field switching mode 0 = Even 1 = Odd

FIELD INTERLEAVED READ MODE WITH 4 FRAMES - 0XC79

Bit	R/W	Default	Description
7:5	R/W	0x0	Reserved
4:0	R/W	0x0	FLI_RD Field interleaved read mode with 4 frames 0 = 2 frames 1 = 4 frames

NEW NON-REAL TIME FIELD SWITCHING MODE FOR PORT 5 - PORT 9 - 0XC7A

Bit	R/W	Default	Description
7:5	R/W	0x0	Reserved
4:0	R/W	0x0	NEW_FLI_SW New field switching mode for non-real time 0 = Original 1 = New field switching

SPOT RECORDING BUFFER 1 CONTROL REGISTER A - 0XC90

Bit	R/W	Default	Description
7	R	0x0	Reserved
6	R/W	0x0	Recording Format Select 0 = Frame Interleaved 1 = Field Interleaved
5:4	R/W	0x0	Recording Resolution Select 00 = D1 01 = Half D1 10 = CIF 11 = VGA (640)
3:0	R/W	0x0	Incoming Channel Select [3:0] = Channel being recorded

SPOT RECORDING BUFFER 1 CONTROL REGISTER B – 0XCA0

Bit	R/W	Default	Description
7	R/W	0x0	Recording Buffer Enable 0 = Disable (default) 1 = Enable
6:3	R/W	0x0	Horizontal Position Select 0000 = 0 0001 = 360 0010 = 720 0011 = 1080 0100 = 1440 0101 = 1800 0110 = 2160 0111 = 2520 Other = reserved
2:0	R/W	0x0	Vertical Position Select 000 = 0 001 = 144 (PAL), 120 (NTSC) 010 = 288 (PAL), 240 (NTSC) 011 = 432 (PAL), 360 (NTSC) 100 = 576 (PAL), 480 (FMI and NTSC) 101 = 720 (PAL), 700 (NTSC) 110 = 1152 (PAL), 960 (NTSC) 111 = 1296 (PAL), 1080 (NTSC)

Similar assignments to other buffers (2-16) follow: 0xC91 - 0xC9F SPOT Recording buffer Control Register A. 0xCA1 - 0xCAF SPOT Recording buffer Control Register B.

BACKGROUND BUFFER INDICATION REGISTER 1 – 0XCC8

Bit	R/W	Default	Description
7:0	R/W	0x0	Record FIFO [7:0] Enable 0 = disable 1 = enable

BACKGROUND BUFFER INDICATION REGISTER 2 – 0XCC9

Bit	R/W	Default	Description
7:0	R/W	0x0	Record FIFO [15:8] Enable 0 = disable 1 = enable

SECOND RECORD BUFFER DRAM CONTROL REGISTER 1 – 0XCCA

Bit	R/W	Default	Description
7:0	R/W	0x0	Second Record DRAM Buffer REC_2nd[7:0] Enable 0 = disable 1 = enable

SECOND RECORD BUFFER DRAM CONTROL REGISTER 2 – 0XCCEB

Bit	R/W	Default	Description
7:0	R/W	0x0	Second Record DRAM Buffer REC_2 nd [15:8] Enable 0 = disable 1 = enable

SECOND SPOT DRAM BUFFER CONTROL REGISTER 1 – 0XCCEC

Bit	R/W	Default	Description
7:0	R/W	0x0	Second Record DRAM Buffer SPOT_2 nd [7:0] Enable 0 = disable 1 = enable

SECOND SPOT DRAM BUFFER CONTROL REGISTER 2 – 0XCCEB

Bit	R/W	Default	Description
7:0	R/W	0x0	Second Record DRAM Buffer SPOT_2 nd [15:8] Enable 0 = disable 1 = enable

RECORD BUFFER ALTERNATE SOURCE CONTROL REGISTER 1 – 0XCCEE

Bit	R/W	Default	Description
7:0	R/W	0x0	Use SPOT Buffer as Record Buffer ALTM[7:0] Enable 0 = disable 1 = enable

RECORD BUFFER ALTERNATE SOURCE CONTROL REGISTER 2 – 0XCCEB

Bit	R/W	Default	Description
7:0	R/W	0x0	Use SPOT Buffer as Record Buffer ALTM[15:8] Enable 0 = disable 1 = enable

RECORD BUFFER HORIZONTAL OFFSET CONTROL REGISTER – 0XCDD0-DF

Bit	R/W	Default	Description
7:0	R/W	0x0	Starting Position to record HSTART[7:0] for CH1-CH16 Unit is 4 pixel

RECORD BUFFER VERTICAL OFFSET CONTROL REGISTER – 0XCE0-EF

Bit	R/W	Default	Description
7:0	R/W	0x0	Starting Position to record VSTART[7:0] for CH1-CH16 Unit is line

SPECIAL COMPONENT RECORD MODE REGISTER – 0XCFO

Bit	R/W	Default	Description
7	R/W	0x0	Single element fetching mode for record port 8 (8D1 possible) 1 = enable, 0 = normal mode
6	R/W	0x0	Synchronized output enable select for record port 9 1 = synchronize with ROUT5, 0 = normal
5	R/W	0x0	Single element fetching mode for record port 7 (8D1 possible) 1 = enable, 0 = normal mode
4	R/W	0x0	Synchronized output enable select for record port 8 1 = synchronize with ROUT5, 0 = normal
3	R/W	0x0	Single element fetching mode for record port 6 (8D1 possible) 1 = enable, 0 = normal mode
2	R/W	0x0	Synchronized output enable select for record port 7 1 = synchronize with ROUT5, 0 = normal
1	R/W	0x0	Single element fetching mode for record port 5 (8D1 possible) 1 = enable, 0 = normal mode
0	R/W	0x0	Synchronized output enable select for record port 6 1 = synchronize with ROUT5, 0 = normal

RECORD BUFFER FIELD SWITCHING RECORD MODE REGISTER 1 – 0XCF1

Bit	R/W	Default	Description
7:0	R/W	0x0	Control recording buffer [7:0] 1 = enable, 0 = normal mode

RECORD BUFFER FIELD SWITCHING RECORD MODE REGISTER 2 – 0XCF2

Bit	R/W	Default	Description
7:0	R/W	0x0	Control recording buffer [15:8] 1 = enable, 0 = normal mode

RECORD BUFFER FIELD SWITCHING RECORD MODE FIELD SELECT REGISTER 1 – 0XCF3

Bit	R/W	Default	Description
7:0	R/W	0x0	Control recording buffer [7:0] 1 = even field, 0 = odd field

RECORD BUFFER FIELD SWITCHING RECORD MODE FIELD SELECT REGISTER 2 – 0XCF4

Bit	R/W	Default	Description
7:0	R/W	0x0	Control recording buffer [15:8] 1 = even field, 0 = odd field

OUTPUT PIN SET SOURCE 2 CONTROL REGISTER A – 0XCF5

Bit	R/W	Default	Description
7:4	R	0x0	Pin Set 2 Source 2 Select[3:0] 1111 = port 8 output high byte 1110 = port 8 output low byte 1101 = port 7 output high byte 1100 = port 7 output low byte (default) 1011 = port 6 output high byte 1010 = port 6 output low byte 1001 = port 5 output high byte 1000 = port 5 output low byte 0111 = port 4 output high byte 0110 = port 4 output low byte 0101 = port 3 output high byte 0100 = port 3 output low byte 0011 = port 2 output high byte 0010 = port 2 output low byte 0001 = port 1 output high byte 0000 = port 1 output low byte
3:0	R/W	0x0	Pin Set 1 Source 2 Select[3:0] 1111 = port 8 output high byte 1110 = port 8 output low byte 1101 = port 7 output high byte 1100 = port 7 output low byte (default) 1011 = port 6 output high byte 1010 = port 6 output low byte 1001 = port 5 output high byte 1000 = port 5 output low byte 0111 = port 4 output high byte 0110 = port 4 output low byte 0101 = port 3 output high byte 0100 = port 3 output low byte 0011 = port 2 output high byte 0010 = port 2 output low byte 0001 = port 1 output high byte 0000 = port 1 output low byte

OUTPUT PIN SET SOURCE 2 CONTROL REGISTER B – 0XCF6

Bit	R/W	Default	Description
7:4	R	0x0	Pin Set 4 Source 2 Select[3:0] 1111 = port 8 output high byte 1110 = port 8 output low byte 1101 = port 7 output high byte 1100 = port 7 output low byte (default) 1011 = port 6 output high byte 1010 = port 6 output low byte 1001 = port 5 output high byte 1000 = port 5 output low byte 0111 = port 4 output high byte 0110 = port 4 output low byte 0101 = port 3 output high byte 0100 = port 3 output low byte 0011 = port 2 output high byte 0010 = port 2 output low byte 0001 = port 1 output high byte 0000 = port 1 output low byte
3:0	R/W	0x0	Pin Set 3 Source 2 Select[3:0] 1111 = port 8 output high byte 1110 = port 8 output low byte 1101 = port 7 output high byte 1100 = port 7 output low byte (default) 1011 = port 6 output high byte 1010 = port 6 output low byte 1001 = port 5 output high byte 1000 = port 5 output low byte 0111 = port 4 output high byte 0110 = port 4 output low byte 0101 = port 3 output high byte 0100 = port 3 output low byte 0011 = port 2 output high byte 0010 = port 2 output low byte 0001 = port 1 output high byte 0000 = port 1 output low byte

FRAME RATE CONTROLLER UPDATE REGISTER – 0XCF7

Bit	R/W	Default	Description
7:0	R/W	0x0	Enable Free Running Recording Port 7-0 1 = enable, 0 = normal mode

SPOT BUFFER FIELD SWITCHING RECORD MODE REGISTER I – 0XCF8

Bit	R/W	Default	Description
7:0	R/W	0x0	Control recording buffer [7:0] 1 = enable, 0 = normal mode

SPOT BUFFER FIELD SWITCHING RECORD MODE REGISTER 2 – 0XCF9

Bit	R/W	Default	Description
7:0	R/W	0x0	Control recording buffer [15:8] 1 = enable, 0 = normal mode

SPOT BUFFER FIELD SWITCHING RECORD MODE FIELD SELECT REGISTER I – 0XCFA

Bit	R/W	Default	Description
7:0	R/W	0x0	Control recording buffer [7:0] 1 = even field, 0 = odd field

SPOT BUFFER FIELD SWITCHING RECORD MODE FIELD SELECT REGISTER 2 – 0XCFB

Bit	R/W	Default	Description
7:0	R/W	0x0	Control recording buffer [15:8] 1 = even field, 0 = odd field

WRITE BUFFER CONTROL REGISTER – 0XCFC

Bit	R/W	Default	Description
7	R/W	0x0	Recording / SPOT Buffers Write Control Enable 0 = disable, 1= enable
6	R	0x0	NEW_FLI_SW_SEL Field selection for new field switching mode 0 = Even 1 = Odd
5	R	0x0	NEW_FLI_SW New field switching mode for non-real time 0 = Original 1 = New field switching
4	R/W	0x0	SPOT_MEM In the SPOT write buffer, buffer write scheme selection control 0 = Use secondary memory area 1 = Use left side memory area for 256 Mb memory
3:2	R/W	0x0	SPOT Buffer Source Skip Select 00 = No skip (default) 01 = skip every 5 frames (fields) 10 = skip every 6 frames (fields) 11 = skip every 7 frames (fields)
1:0	R/W	0x0	Recording Buffer Source Skip Select 00 = No skip (default) 01 = skip every 5 frames (fields) 10 = skip every 6 frames (fields) 11 = skip every 7 frames (fields)

NEW FRSC CONTROL REGISTER A – 0XCFD

Bit	R/W	Default	Description
7:6	R/W	0x0	FLD_FRSC New frame rate control method by using field signal 0x = original frame rate control 10 = new frame rate control, wr_page[0] = field 11 = new frame rate control, wr_page[0] = ~field
5	R/W	0x0	NEW_EN New method for mapping wr_buffers to read ports 00 = original mapping 01 = new mapping, each read port selects write buffers by setting register 0xCFD[4:0] and 0xCFE[7:0]
4:0	R/W	0x0	EN_ADDRI Read port index 0 = port5, recording write buffer 0 ~ 7 selection 1 = port5, recording write buffer 8 ~ 15 selection 2 = port5, SPOT write buffer 0 ~ 7 selection 3 = port5, SPOT write buffer 8 ~ 15 selection 4 = port6, recording write buffer 0 ~ 7 selection 5 = port6, recording write buffer 8 ~ 15 selection 6 = port6, SPOT write buffer 0 ~ 7 selection 7 = port6, SPOT write buffer 8 ~ 15 selection 8 = port7, recording write buffer 0 ~ 7 selection 9 = port7, recording write buffer 8 ~ 15 selection 10 = port7, SPOT write buffer 0 ~ 7 selection 11 = port7, SPOT write buffer 8 ~ 15 selection 12 = port8, recording write buffer 0 ~ 7 selection 13 = port8, recording write buffer 8 ~ 15 selection 14 = port8, SPOT write buffer 0 ~ 7 selection 15 = port8, SPOT write buffer 8 ~ 15 selection 16 = network, recording write buffer 0 ~ 7 selection 17 = network, recording write buffer 8 ~ 15 selection 18 = network, SPOT write buffer 0 ~ 7 selection 19 = network, SPOT write buffer 8 ~ 15 selection

NEW WRITE BUFFER MAPPING CONTROL REGISTER– 0XCFF

Bit	R/W	Default	Description
7:0	R/W	0x0	EN_DATA New write buffer mapping control data According to the value of EN_ADDRI(0xCFD[4:0]), this value select write buffer for each read port 0 = disable, 1= enable

Motion Dection Unit

Introduction

TW2880 has motion detection circuitry for each incoming video channels (all together the number is 16). The source of MD circuit is the 16 D1 stream coming from the input. To do the job, TW2880 divided the first field of each stream into a 16x12 cell array. From here a unique signature for each cell is extracted and saved into DRAM buffer for later use. The second field of each frame is discarded for simplicity and cost issue. The motion detection algorithm compares the difference of luminance value between current field and reference field to determine whether a motion has occurred.

Uses the same detection engine, TW2880 also supports blind and night detection. The motion detector is operated with the second memory controller module.

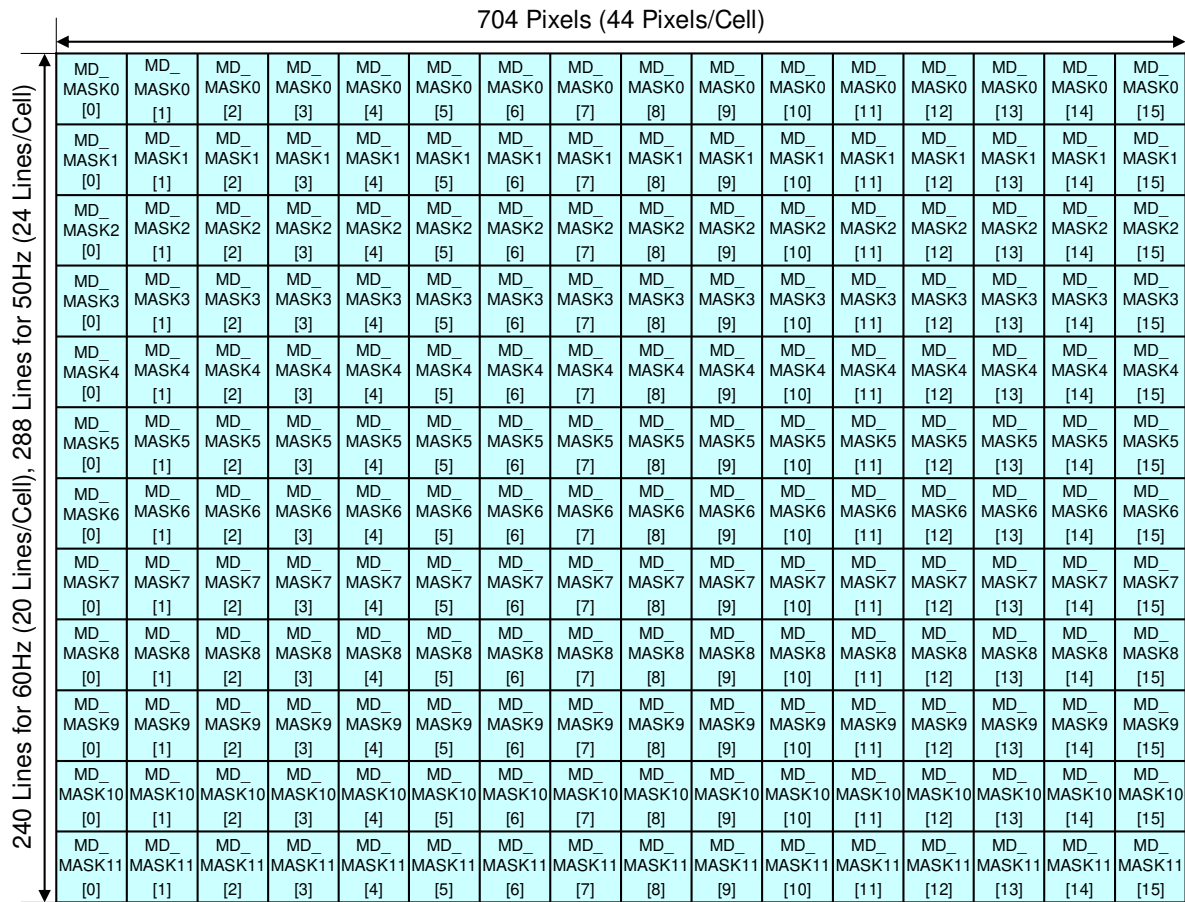
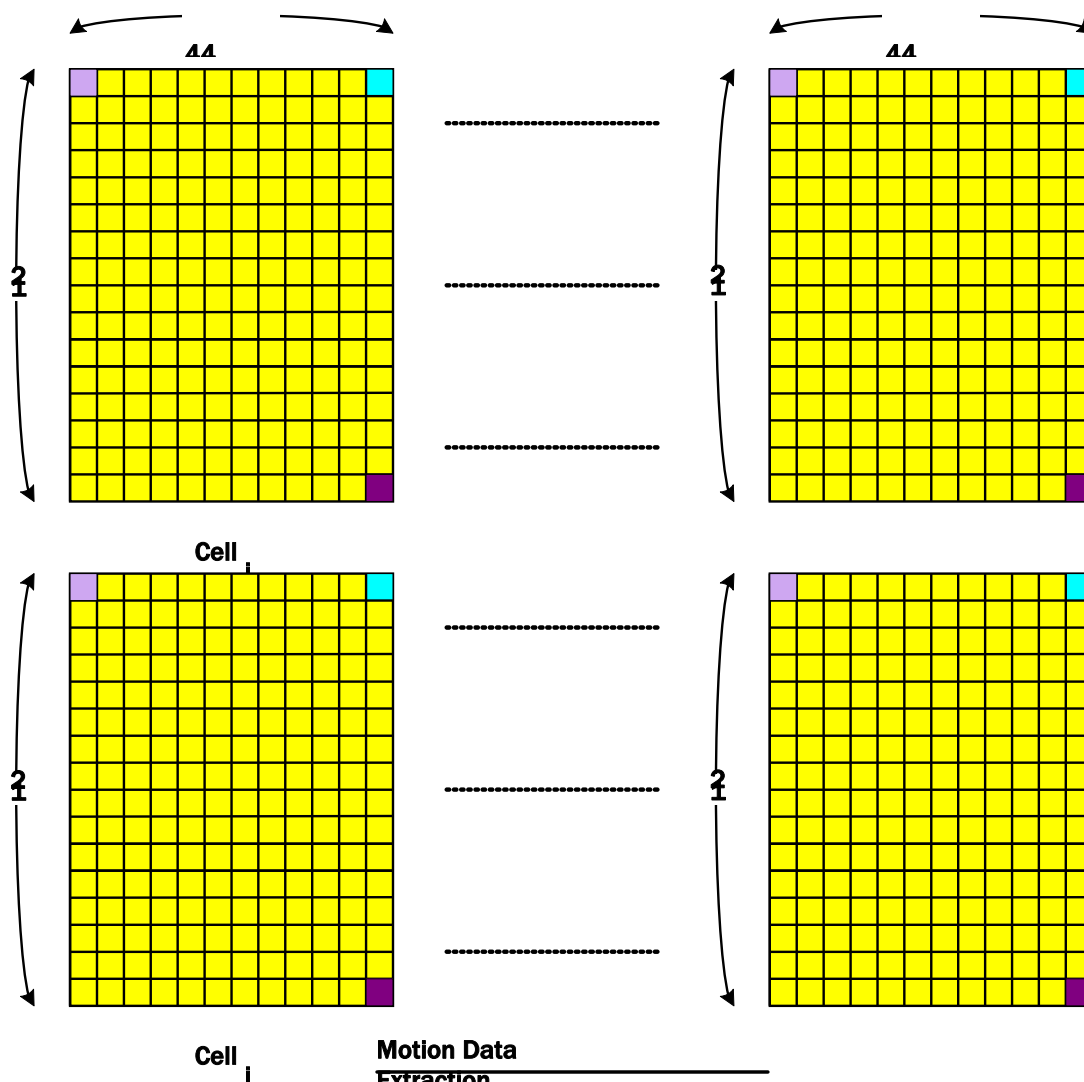

FIGURE 22. MOTION DETECTION MASK AND CELL DEFINITION

Motion Data Extraction

Motion data extraction process is followed the scan order, from left to right and from top to bottom, performed on a line by line basis. First, the luminance value of each pixel within a cell is added together and divided by a fixed value. The result is stored into a 16x13 FIFO. Please remember the number of horizontal pixels is flexible so the number of pixels in each cell line varies. This adding and dividing process will repeat itself until it reaches the end of the cell where it will repeat 20 times. Each time a new line luminance value is created; it will be added with the previous one and divided with a fixed number. In the end, an 8 bit number is extracted to represent each cell. So for each frame, the data storage needed is:

8 x 16 = 128 bit (for a cell row)
 128 x 12 / 8 = 192 Byte (for a motion frame)



Mask and Detection Region Selection

The motion detection algorithm utilizes the full screen video data and detects individual motion of 32x24 cells. Like the extraction process, this full screen for motion detection consists of 704 pixels and 240 lines for NTSC and 288 lines for PAL.

Each cell can be masked via the MD_MASK (0x800/0x900/0xa00/0xb00 ~ 0x817/0x917/0xa17/0xb17, 0x840/0x940/0xa40/0xb40 ~ 0x857/0x957/0xa57/0xb57, 0x880/0x980/0xa80/0xb80 ~ 0x897/0x997/0xa97/0xb97, 0x8c0/0x9c0/0xac0/0xbc0 ~ 0x8d7/0x9d7/0xad7/0xbd7) register as illustrated in Fig 7. If the mask bit in specific cell is programmed to high, the related cell is ignored for motion detection.

The motion detection result is stored in registers (0x820/0x920/0xa20/0xb20 ~ 0x837/0x937/0xa37/0xb37, 0x860/0x960/0xa60/0xb60 ~ 0x877/0x977/0xa77/0xb77, 0x8a0/0x9a0/0xaa0/0xba0 ~ 0x8b7/0x9b7/0xab7/0xbb7, 0x8e0/0x9e0/0xae0/0xbe0 ~ 0x8f7/0x9f7/0xaf7/0xbf7) and an "1" indicates detecting motion and "0" denotes no motion detection in the cell.

To detect motion properly according to situation, TW2880 provides several sensitivity and velocity control parameters for each motion detector. TW2880 supports manual strobe function to update motion detection so that it is more appropriate for user-defined motion sensitivity control.

When no video, motion, blind and night conditions are detected in any video inputs, TW2880 provides the interrupt request to host via the IRQ pin if you enable the request line. The host processor can read the information of motion, blind or night detection by accessing the No Video IRQ Status Register (0xCB9, 0xCB8), Motion IRQ Status Register (0xCBB, 0xCBA), Blind Detection IRQ Status Register (0xCBD, 0xCBC) and the Night Detection IRQ Status Register (0xCBF, 0xCBE). This status information is updated in the vertical blank period of each input.

TW2880 supports an overlay function to display the motion detection result in the picture with 2D arrayed box. Motion detection information can display using the 2-D Box in RGB Path, Record Path can display by Channel ID type. We can get this information from host interface (Status Read) or used by Interrupt / General Purpose IO pin.

Sensitivity Control

The motion detector has 4 sensitivity parameters to control threshold of motion detection such as the level sensitivity via the MD_LVSENS register, the spatial sensitivity via the MD_SPSSENS and MD_CELSENS register, and the temporal sensitivity parameter via the MD_TMPSENS register.

LEVEL SENSITIVITY

In built-in motion detection algorithm, the motion is detected when luminance level difference between current and reference field is greater than MD_LVSENS value. Motion detector is more sensitive for the smaller MD_LVSENS value and less sensitive for the larger. When the MD_LVSENS is too small, the motion detector may be weak in noise.

SPATIAL SENSITIVITY

The TW2880 uses 192 (16x12) detection cells in full screen for motion detection. Each detection cell is composed of 44 pixels and 20 lines for NTSC and 24 lines for PAL. Motion detection from only luminance level difference between two fields is very weak in spatial random noise. To remove the fake motion detection from the random noise, the TW2880 supports a spatial filter via the MD_SPSSENS register which defines the number of detected cell to decide motion detection in full size image. The large MD_SPSSENS value increases the immunity of spatial random noise.

Each detection cell has 4 sub-cells also. Actually motion detection of each cell comes from comparison of sub-cells in it. The MD_CELSENS defines the number of detected sub-cell to decide motion detection in cell. That is, the large MD_CELSENS value increases the immunity of spatial random noise in detection cell.

TEMPORAL SENSITIVITY

Similarly, temporal filter is used to remove the fake motion detection from the temporal random noise. The MD_TMPSENS regulates the number of taps in the temporal filter to control the temporal sensitivity so that the large MD_TMPSENS value increases the immunity of temporal random noise.

VELOCITY CONTROL

The motion has various velocities. That is, in a fast motion an object appears and disappears rapidly between the adjacent fields while in a slow motion it is to the contrary. As the built-in motion detection algorithm uses the only luminance level difference between two adjacent fields, a slow motion is inferior in detection rate to a fast motion. To compensate this weakness, MD_SPEED parameter is used which is controllable up to 64 fields(2seconds) for NTSC and 30 fields(2seconds) for PAL 64bit SDRAM and 15 fields(1second) for PAL 32bit SDRAM. MD_SPEED parameter adjusts the field interval in which the luminance level is compared. Thus, for detection of a fast motion a small value is needed and for a slow motion a large value is required. The parameter MD_SPEED value should be greater than MD_TMPSENS value.

Additionally, TW2880 has 2 more parameters to control the selection of reference field. The MD_FIELD[1:0] bit is a field selection parameter such as odd, even, any field or frame.

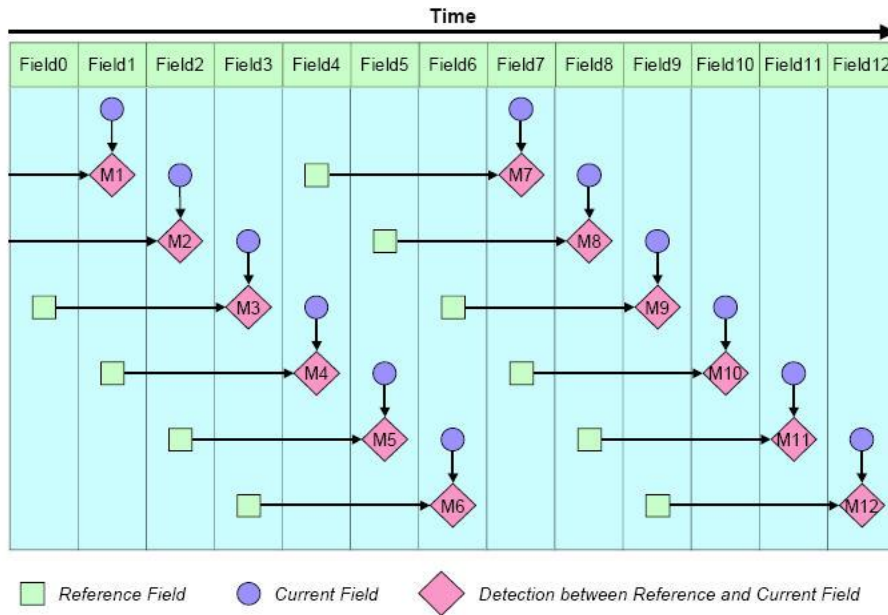

Fig 17 The relat

FIGURE 23. THE RELATIONSHIP BETWEEN CURRENT AND REFERENCE FIELD WHEN MD_REFFLD = "0"

The MD_REFFLD bit is designed to control the updating period of reference field. If MD_REFFLD = "0", the interval from current field to reference field is always same as the MD_SPEED. It means that the reference field is always updated every field. The Figure 23 shows the relationship between current and reference field for motion detection when MD_REFFLD is set to 0.

TW2880 can update the reference field only at the period of MD_SPEED when the MD_REFFLD is high. For this case, the TW2880 can detect a motion with sense of a various velocity. The Fig 18 shows the relationship between current and reference field for motion detection when the MD_REFFLD equals to 1.

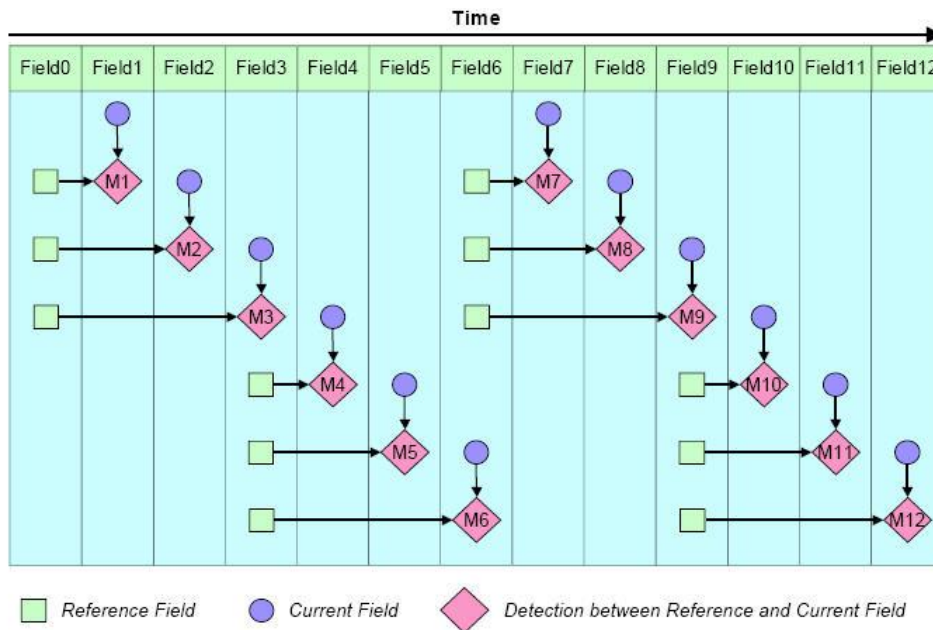

Fig 18 The re

FIGURE 24. THE RELATIONSHIP BETWEEN CURRENT AND REFERENCE FIELD WHEN MD_REFFLD = "1"

TW2880 also supports the manual detection timing control of the reference field/frame via the MD_STRB_EN and MD_STRB register bits in the MD control registers. If MD_STRB_EN is set to 0, the reference field/frame is automatically updated and reserved on every reference field/frame. If MD_STRB_EN is set to 1, the reference field/frame is updated and reserved only when MD_STRB bit is set to 1. If an external strobing signal is used, one can set the mode to 1x and select it. The strobe signal is coming from outside via trigger_in pin. In these two modes, the interval between current and reference field/frame is controlled by user's strobe timing and are very useful for some specific purpose like non-periodical velocity control and very slow motion detection.

Blind Detection

If the luminous level of a video input in every corner area is almost equal to the average luminous level of this frame due to camera got covered by something, this input is defined as blind input. TW2880 supports blind detection individually for all 16 video inputs and generates an interrupt to host CPU.

TW2880 uses two sensitivity parameters to detect blind input. One is the level sensitivity via the BD_LVSENS register and the other is spatial sensitivity via the BD_CELSENS register. The TW2880 uses total 192 (16x12) cells in full screen for blind detection. The BD_LVSENS parameter controls the threshold of level between cell and field average. The BD_CELSENS parameter defines the number of cells to detect blind. For BD_CELSENS = "0", the number of cell whose level is same as average of field should be over than 60% to detect blind, 70% for BD_CELSENS = "1", 80% for BD_CELSENS = "2", and 90% for BD_CELSENS = "3". That is, the large value of BD_LVSENS and BD_CELSENS makes blind detector less sensitive.

TW2880 also supports dual detection mode for non real time application such as pseudo 8ch application via the MD_DUAL_EN register. The host can read blind detection information for both VIN_A and VIN_B input via the IRQENA_BD (0x17A) register.

Night Detection

TW2880 uses a user defined, fixed value to determine whether a video input is in a broad day light or at night situations. If the average of luminous level is lower than this fixed value, this input is defined as night input. Likewise, the opposite is defined as day input. The TW2880 supports night detection for all 16 video inputs and will generated interrupts to host CPU if triggered.

Two parameters are used to detect night input. One is the level sensitivity via the ND_LVSENS register and the other is temporal sensitivity via the ND_TMPSENS register. The ND_LVSENS parameter controls threshold level of day and night. The ND_TMPSENS parameter regulates the number of taps in the temporal low pass filter to control the temporal sensitivity. The large value of ND_LVSENS and ND_TMPSENS makes night detector less sensitive.

The TW2880 also supports dual detection mode for non-real-time application such as pseudo 8ch application via the MD_DUAL_EN register. The host can read night detection information for both VIN_A and VIN_B input via the IRQENA_ND (0x17B) register.

Register Table

Address	R/W	Default	Description
0x800	R/W	0x00	Motion Detection Cell Line 0 Mask Register 1
0x801	R/W	0x00	Motion Detection Cell Line 0 Mask Register 2
0x802	R/W	0x00	Motion Detection Cell Line 1 Mask Register 1
0x803	R/W	0x00	Motion Detection Cell Line 1 Mask Register 2
0x804	R/W	0x00	Motion Detection Cell Line 2 Mask Register 1
0x805	R/W	0x00	Motion Detection Cell Line 2 Mask Register 2
0x806	R/W	0x00	Motion Detection Cell Line 3 Mask Register 2
0x807	R/W	0x00	Motion Detection Cell Line 3 Mask Register 1
0x808	R/W	0x00	Motion Detection Cell Line 4 Mask Register 2
0x809	R/W	0x00	Motion Detection Cell Line 4 Mask Register 1
0x80A	R/W	0x00	Motion Detection Cell Line 5 Mask Register 1
0x80B	R/W	0x00	Motion Detection Cell Line 5 Mask Register 2
0x80C	R/W	0x00	Motion Detection Cell Line 6 Mask Register 1
0x80D	R/W	0x00	Motion Detection Cell Line 6 Mask Register 2
0x80E	R/W	0x00	Motion Detection Cell Line 7 Mask Register 1
0x80F	R/W	0x00	Motion Detection Cell Line 7 Mask Register 2
0x810	R/W	0x00	Motion Detection Cell Line 8 Mask Register 1
0x811	R/W	0x00	Motion Detection Cell Line 8 Mask Register 2
0x812	R/W	0x00	Motion Detection Cell Line 9 Mask Register 1
0x813	R/W	0x00	Motion Detection Cell Line 9 Mask Register 2
0x814	R/W	0x00	Motion Detection Cell Line 10 Mask Register 1
0x815	R/W	0x00	Motion Detection Cell Line 10 Mask Register 2
0x816	R/W	0x00	Motion Detection Cell Line 11 Mask Register 1
0x817	R/W	0x00	Motion Detection Cell Line 11 Mask Register 2
0x818	R/W	0x00	Motion Detection Control Register 1
0x819	R/W	0x00	Motion Detection Control Register 2
0x81A	R/W	0x00	Motion Detection Control Register 3
0x81B	R/W	0x00	Motion Detection Control Register 4
0x81E	R/W	0x00	Motion Detection Control Register 5
0x81F	R/W	0x00	Motion Detection Control Register 6
0x820	R/W	0x00	Motion Detection Cell Line 0 Result Register 1
0x821	R/W	0x00	Motion Detection Cell Line 0 Result Register 2
0x822	R/W	0x00	Motion Detection Cell Line 1 Result Register 1
0x823	R/W	0x00	Motion Detection Cell Line 1 Result Register 2
0x824	R/W	0x00	Motion Detection Cell Line 2 Result Register 1
0x825	R/W	0x00	Motion Detection Cell Line 2 Result Register 2
0x826	R/W	0x00	Motion Detection Cell Line 3 Result Register 1
0x827	R/W	0x00	Motion Detection Cell Line 3 Result Register 2
0x828	R/W	0x00	Motion Detection Cell Line 4 Result Register 1
0x829	R/W	0x00	Motion Detection Cell Line 4 Result Register 2
0x82A	R/W	0x00	Motion Detection Cell Line 5 Result Register 1
0x82B	R/W	0x00	Motion Detection Cell Line 5 Result Register 2
0x82C	R/W	0x00	Motion Detection Cell Line 6 Result Register 1
0x82D	R/W	0x00	Motion Detection Cell Line 6 Result Register 2
0x82E	R/W	0x00	Motion Detection Cell Line 7 Result Register 1
0x82F	R/W	0x00	Motion Detection Cell Line 7 Result Register 2
0x830	R/W	0x00	Motion Detection Cell Line 8 Result Register 1
0x831	R/W	0x00	Motion Detection Cell Line 8 Result Register 2
0x832	R/W	0x00	Motion Detection Cell Line 9 Result Register 1
0x833	R/W	0x00	Motion Detection Cell Line 9 Result Register 2
0x834	R/W	0x00	Motion Detection Cell Line 10 Result Register 1

Address	R/W	Default	Description
0x835	R/W	0x00	Motion Detection Cell Line 10 Result Register 2
0x836	R/W	0x00	Motion Detection Cell Line 11 Result Register 1
0x837	R/W	0x00	Motion Detection Cell Line 11 Result Register 2

Registers Description

MOTION DETECTION CELL LINE 0 MASK REGISTER 1 – 0X800

Bit	R/W	Default	Description
7:0	R/W	0x0	MD_MASK0[7:0]

This is for channel 0. For other channel the assignments are: 0x840, 0x880, 0x8C0, 0x900, 0x940, 0x980, 0x9C0, 0xA00, 0xA40, 0xA80, 0xAC0, 0xB00, 0xB40, 0xB80, 0xBC0 respectively

MOTION DETECTION CELL LINE 0 MASK REGISTER 2 – 0X801

Bit	R/W	Default	Description
7:0	R/W	0x0	MD_MASK0[15:8]

MOTION DETECTION CELL LINE 1 MASK REGISTER 1 – 0X802

Bit	R/W	Default	Description
7:0	R/W	0x0	MD_MASK1[7:0]

MOTION DETECTION CELL LINE 1 MASK REGISTER 2 – 0X803

Bit	R/W	Default	Description
7:0	R/W	0x0	MD_MASK1[15:8]

MOTION DETECTION CELL LINE 2 MASK REGISTER 1 – 0X804

Bit	R/W	Default	Description
7:0	R/W	0x0	MD_MASK2[7:0]

MOTION DETECTION CELL LINE 2 MASK REGISTER 2 – 0X805

Bit	R/W	Default	Description
7:0	R/W	0x0	MD_MASK2[15:8]

MOTION DETECTION CELL LINE 3 MASK REGISTER 1 – 0X806

Bit	R/W	Default	Description
7:0	R/W	0x0	MD_MASK3[7:0]

MOTION DETECTION CELL LINE 3 MASK REGISTER 2 – 0X807

Bit	R/W	Default	Description
7:0	R/W	0x0	MD_MASK3[15:8]

MOTION DETECTION CELL LINE 4 MASK REGISTER 1 – 0X808

Bit	R/W	Default	Description
7:0	R/W	0x0	MD_MASK4[7:0]

MOTION DETECTION CELL LINE 4 MASK REGISTER 2 – 0X809

Bit	R/W	Default	Description
7:0	R/W	0x0	MD_MASK4[15:8]

MOTION DETECTION CELL LINE 5 MASK REGISTER 1 – 0X80A

Bit	R/W	Default	Description
7:0	R/W	0x0	MD_MASK5[7:0]

MOTION DETECTION CELL LINE 5 MASK REGISTER 2 – 0X80B

Bit	R/W	Default	Description
7:0	R/W	0x0	MD_MASK5[15:8]

MOTION DETECTION CELL LINE 6 MASK REGISTER 1 – 0X80C

Bit	R/W	Default	Description
7:0	R/W	0x0	MD_MASK6[7:0]

MOTION DETECTION CELL LINE 6 MASK REGISTER 2 – 0X80D

Bit	R/W	Default	Description
7:0	R/W	0x0	MD_MASK6[15:8]

MOTION DETECTION CELL LINE 7 MASK REGISTER 1 – 0X80E

Bit	R/W	Default	Description
7:0	R/W	0x0	MD_MASK7[7:0]

MOTION DETECTION CELL LINE 7 MASK REGISTER 2 – 0X80F

Bit	R/W	Default	Description
7:0	R/W	0x0	MD_MASK7[15:8]

MOTION DETECTION CELL LINE 8 MASK REGISTER 1 – 0X810

Bit	R/W	Default	Description
7:0	R/W	0x0	MD_MASK8[7:0]

MOTION DETECTION CELL LINE 8 MASK REGISTER 2 – 0X811

Bit	R/W	Default	Description
7:0	R/W	0x0	MD_MASK8[15:8]

MOTION DETECTION CELL LINE 9 MASK REGISTER 1 – 0X812

Bit	R/W	Default	Description
7:0	R/W	0x0	MD_MASK9[7:0]

MOTION DETECTION CELL LINE 9 MASK REGISTER 2 – 0X813

Bit	R/W	Default	Description
7:0	R/W	0x0	MD_MASK9[15:8]

MOTION DETECTION CELL LINE 10 MASK REGISTER 1 – 0X814

Bit	R/W	Default	Description
7:0	R/W	0x0	MD_MASK10[7:0]

MOTION DETECTION CELL LINE 10 MASK REGISTER 2 – 0X815

Bit	R/W	Default	Description
7:0	R/W	0x0	MD_MASK10[15:8]

MOTION DETECTION CELL LINE 11 MASK REGISTER 1 – 0X816

Bit	R/W	Default	Description
7:0	R/W	0x0	MD_MASK11[7:0]

MOTION DETECTION CELL LINE 11 MASK REGISTER 2 – 0X817

Bit	R/W	Default	Description
7:0	R/W	0x0	MD_MASK11[15:8]

MOTION DETECTION CONTROL REGISTER 1 – 0X818

Bit	R/W	Default	Description
7	R/W	0x0	MD_DIS, channel disable, 1 = disable
6	R/W	0x0	Reserved
5:4	R/W	0x0	BD_CELLSSENS, blind cell sensitivity adjust 00 = 60% 01 = 70% 10 = 80% 11 = 90%
3:0	R/W	0x0	BD_LVSENS, Blind level sensitivity select

MOTION DETECTION CONTROL REGISTER 2 – 0X819

Bit	R/W	Default	Description
7:4	R/W	0x0	ND_LVSENS, night detection level sensitivity adjust
3:0	R/W	0x0	ND_TMPSENS, night detection temporal sensitivity adjust

MOTION DETECTION CONTROL REGISTER 3 – 0X81A

Bit	R/W	Default	Description
7:6	R/W	0x0	MD_FIELD, motion detection field select
5	R/W	0x0	Reserved
4:0	R/W	0x0	MD_LVSENS, motion detection level sensitivity adjust

MOTION DETECTION CONTROL REGISTER 4 – 0X81B

Bit	R/W	Default	Description
7	R/W	0x0	Reserved
6	R/W	0x0	MD_REFFLD, Reference Field Update Mode 0 : Update Every Field, 1 : Update Every MD_SPEED Period
5:0	R/W	0x0	MD_SPEED, temporal sensitivity adjust

MOTION DETECTION CONTROL REGISTER 5 – 0X81E

Bit	R/W	Default	Description
7:4	R/W	0x0	MD_TMPSENS, motion detection temporal sensitivity adjust
3:0	R/W	0x0	MD_SPSSENS, motion spatial sensitivity adjust

MOTION DETECTION CONTROL REGISTER 6 – 0X81F

Bit	R/W	Default	Description
7	R/W	0x0	MD_VINV, motion detection display mode, 1 = vertical invert
6	R/W	0x0	MD_HINV, motion detection display mode, 1 = horizontal invert
5:4	R/W	0x0	MD_CELLSSENS, Define the threshold of sub-cell number for motion detection 0 = Motion is detected if 1 sub-cell has motion(default) 1 = Motion is detected if 2 sub-cell has motion 2 = Motion is detected if 3 sub-cell has motion 3 = Motion is detected if 4 sub-cell has motion(less sensitive)
3	R/W	0x0	Reserved
2	R/W	0x0	MD_STRB, internal user strobe signal
1:0	R/W	0x0	Strobe mode 00 = automatic mode 01 = internal strobe mode, MD_STRB_EN = 1 1x = external strobe mode

MOTION DETECTION CELL LINE 0 RESULT REGISTER 1 – 0X820

Bit	R/W	Default	Description
7:0	R	0x0	md_det0[7:0]

This is for channel 0. For other channel the assignments are: 0x860, 0x8A0, 0x8E0, 0x920, 0x960, 0x9A0, 0x9E0, 0xA20, 0xA60, 0xAA0, 0xAE0, 0xB20, 0xB60, 0xBA0, 0xBE0 respectively

MOTION DETECTION CELL LINE 0 RESULT REGISTER 2 – 0X821

Bit	R/W	Default	Description
7:0	R	0x0	md_det0[15:8]

MOTION DETECTION CELL LINE 1 RESULT REGISTER 1 – 0X822

Bit	R/W	Default	Description
7:0	R	0x0	md_det1[7:0]

MOTION DETECTION CELL LINE 1 RESULT REGISTER 2 – 0X823

Bit	R/W	Default	Description
7:0	R	0x0	md_det1[15:8]

MOTION DETECTION CELL LINE 2 RESULT REGISTER 1 – 0X824

Bit	R/W	Default	Description
7:0	R	0x0	md_det2[7:0]

MOTION DETECTION CELL LINE 2 RESULT REGISTER 2 – 0X825

Bit	R/W	Default	Description
7:0	R	0x0	md_det2[15:8]

MOTION DETECTION CELL LINE 3 RESULT REGISTER 1 – 0X826

Bit	R/W	Default	Description
7:0	R	0x0	md_det3[7:0]

MOTION DETECTION CELL LINE 3 RESULT REGISTER 2 – 0X827

Bit	R/W	Default	Description
7:0	R	0x0	md_det3[15:8]

MOTION DETECTION CELL LINE 4 RESULT REGISTER 1 – 0X828

Bit	R/W	Default	Description
7:0	R	0x0	md_det4[7:0]

MOTION DETECTION CELL LINE 4 RESULT REGISTER 2 – 0X829

Bit	R/W	Default	Description
7:0	R	0x0	md_det4[15:8]

MOTION DETECTION CELL LINE 5 RESULT REGISTER 1 – 0X82A

Bit	R/W	Default	Description
7:0	R	0x0	md_det5[7:0]

MOTION DETECTION CELL LINE 5 RESULT REGISTER 2 – 0X82B

Bit	R/W	Default	Description
7:0	R	0x0	md_det5[15:8]

MOTION DETECTION CELL LINE 6 RESULT REGISTER 1 – 0X82C

Bit	R/W	Default	Description
7:0	R	0x0	md_det6[7:0]

MOTION DETECTION CELL LINE 6 RESULT REGISTER 2 – 0X82D

Bit	R/W	Default	Description
7:0	R	0x0	md_det6[15:8]

MOTION DETECTION CELL LINE 7 RESULT REGISTER 1 – 0X82E

Bit	R/W	Default	Description
7:0	R	0x0	md_det7[7:0]

MOTION DETECTION CELL LINE 7 RESULT REGISTER 2 – 0X82F

Bit	R/W	Default	Description
7:0	R	0x0	md_det7[15:8]

MOTION DETECTION CELL LINE 8 RESULT REGISTER 1 – 0X830

Bit	R/W	Default	Description
7:0	R	0x0	md_det8[7:0]

MOTION DETECTION CELL LINE 8 RESULT REGISTER 2 – 0X831

Bit	R/W	Default	Description
7:0	R	0x0	md_det8[15:8]

MOTION DETECTION CELL LINE 9 RESULT REGISTER 1 – 0X832

Bit	R/W	Default	Description
7:0	R	0x0	md_det9[7:0]

MOTION DETECTION CELL LINE 9 RESULT REGISTER 2 – 0X833

Bit	R/W	Default	Description
7:0	R	0x0	md_det9[15:8]

MOTION DETECTION CELL LINE 10 RESULT REGISTER 1 – 0X834

Bit	R/W	Default	Description
7:0	R	0x0	md_det10[7:0]

MOTION DETECTION CELL LINE 10 RESULT REGISTER 2 – 0X835

Bit	R/W	Default	Description
7:0	R	0x0	md_det10[15:8]

MOTION DETECTION CELL LINE 11 RESULT REGISTER 1 – 0X836

Bit	R/W	Default	Description
7:0	R	0x0	md_det11[7:0]

MOTION DETECTION CELL LINE 11 RESULT REGISTER 2 – 0X837

Bit	R/W	Default	Description
7:0	R	0x0	md_det11[15:8]

Channel ID Encoder Unit

Channel ID Encoder

The video output sequences from each of the TW2880 output port have critical system information embedded in the VBI area called channel ID. This information is very useful for the people who try to capture and utilize the video sequence later on. TW2880 supports three kinds of channel ID: User channel ID, Detection channel ID and Auto channel ID. The output order of these IDs in a TW2880 generated video sequence is fixed as Auto -> Repeat Auto(only in analog format) -> Detection -> User Channel ID. Definitions of each channel ID are described in detailed in the following sections. Each channel ID unit for each output port can be enabled and disabled independently. The Channel ID Format of TW2880 is very similar to TW2835, but total amount of data increase a little bit.

Channel ID Definition

AUTO CHANNEL ID

TW2880's Auto channel ID is 5 bytes long and is used for automatic identification of picture configuration such as video input path number, analog switch, event, region enable, field/frame mode information and CIF channel info. The ID information will repeat once.

TYPE	BIT	NAME	FUNCTION
Auto Channel ID	[39:38]	ID_TYPE	2'b00 = Auto Channel ID
	[37:36]	LINE_NUM	Line Number : 0 : 1 st Line, 1 : 2 nd Line (auto repeat)
	[35]	F_OUT	Encoder Field Polarity. 0 : Odd, 1 : Even
	[34:32]	Record port	0 - 7 = Rec0 - Rec7
	[31:28]	CH_NUM1	1/4 Quadrant Channel Number
	[27:24]	CH_NUM2	2/4 Quadrant Channel Number
	[23:20]	CH_NUM3	3/4 Quadrant Channel Number
	[19:16]	CH_NUM4	4/4 Quadrant Channel Number
	[15]	Interleave	0: Frame, 1: Field
	[14]	Interlace	In frame interleave, 0: Progressive, 1: Interlaced. In field interleave, 0: non field switch, 1: field switch
	[13:12]	Resolution	0 : Full D1, 1 : CIF, 2 : 4D1, 3 : BT1120
	[11]	H_SPLIT	0: no split, 1: split
	[10]	V_SPLIT	0: no split, 1: split
	[9]	FLD_MODE	0: top field is 0, 1: top field is 1
[8]	-	0: [7:4] use for no video, 1: [7:4] is used for ignored bit	

TYPE	BIT	NAME	FUNCTION
	[7:0]	DET_INFO	[7]: No video or ignored function for 1/4 quadrant channel [6]: No video or ignored function for 2/4 quadrant channel [5]: No video or ignored function for 3/4 quadrant channel [4]: No video or ignored function for 4/4 quadrant channel [3]: Blind for 1/4 quadrant channel [2]: Blind for 2/4 quadrant channel [1]: Blind for 3/4 quadrant channel [0]: Blind for 4/4 quadrant channel

DETECTION CHANNEL ID

Detection channel ID is composed of 40 byte data (8 lines) and is used for real time detected information such as motion, video loss, blind and night detection.

TYPE	BIT	NAME	FUNCTION
Detection Channel ID	[39:38]	ID_TYPE	Detection Channel ID = 2'b10
	[37:36]	LINE_NUM	Line Number : 0 : 1 st Line, 1 : 2 nd Line
	[35]	F_OUT	Encoder Field Polarity. 0 : Odd, 1 : Even
	[34:32]	Record port	0 - 7 = Rec0 - Rec7
	[31:0]	DET_INFO	[31:28] : 0/8 Ch DET_INFO (two lines) ~~ [03:00] : 7/15 Ch DET_INFO DET_INFO[3] : Video Loss Information DET_INFO[2] : Motion Information DET_INFO[1] : Blind Information DET_INFO[0] : Night Information

196-bit motion detection information is also included in Detection channel ID, total is 24 bytes (6 lines). Two lines use ID_TYPE 2'b10, the rest four lines use ID_TYPE 2'b01;

TYPE	BIT	NAME	FUNCTION
Detection Channel ID	[39:38]	ID_TYPE	Motion Detection Channel ID = 2'b10 (shared)
	[37:36]	LINE_NUM	Line Number : 2 : 3 rd Line, 3 : 4 th Line
	[35:32]	MD_SEL	Which channel is shown on 192 bits.
	[31:0]	DET_INFO	Line2: MD_DET[191:160] : Motion Detection Info Line3: MD_DET[159:128] : Motion Detection Info

TYPE	BIT	NAME	FUNCTION
Detection Channel ID	[39:38]	ID_TYPE	Motion Detection Channel ID = 2'b01
	[37:36]	LINE_NUM	Line Number : 0 : 5 th Line, 1 : 6 th Line, 2 : 7 th line, 3 : 8 th line
	[35:32]	MD_SEL	Which channel is shown on 192 bits.
	[31:0]	DET_INFO	Line 0: MD_DET[127:96] : Motion Detection Info Line 1: MD_DET[95:64] : Motion Detection Info Line 2: MD_DET[63: 32] : Motion Detection Info Line 3: MD_DET[31:0] : Motion Detection Info

192 bit motion information is only for one channel. Each channel is divided by 16x12=192 windows. Each bit indicates 1 window motion status. To select different channel motion data, configure register MOTION_SEL.

USER CHANNEL ID

User Channel ID is composed of 15 bytes data (three lines) and is used for indicating customized information such as system information and date.

TYPE	BIT	NAME	FUNCTION
User Channel ID	[39:38]	ID_TYPE	2'b11 = User Channel ID
	[37:36]	LINE_NUM	Line Number : 0 : 1 st Line, 1 : 2 nd Line, 2 : 3 rd Line
	[35]	F_OUT	Encoder Field Polarity. 0 : Odd, 1 : Even
	[34:32]	Record port	0 - 7 = Rec0 - Rec7
	[31:0]	MAN_ID	[31:0] : Manual User ID

Channel ID Output Method

TW2880 has two ways of transmitting channel ID: analog type channel ID and digital type channel ID. There are totally 14 lines channel ID data, which include 1 line of digital channel ID and 13 lines of analog channel ID. In analog channel ID, there are 1 line of auto channel ID, 1 line repeat auto channel ID, 8 lines of detection channel ID and 3 lines of user channel ID.

1	Digital channel ID
2	Analog auto channel ID
3	Analog auto repeat channel ID
4	Analog detection channel ID 1
5	Analog detection channel ID 2
6	Analog detection channel ID 3
7	Analog detection channel ID 4
8	Analog detection channel ID 5
9	Analog detection channel ID 6
10	Analog detection channel ID 7
11	Analog detection channel ID 8
12	Analog user channel ID 1
13	Analog user channel ID 2
14	Analog user channel ID 3

CHANNEL ID LINE NUMBER

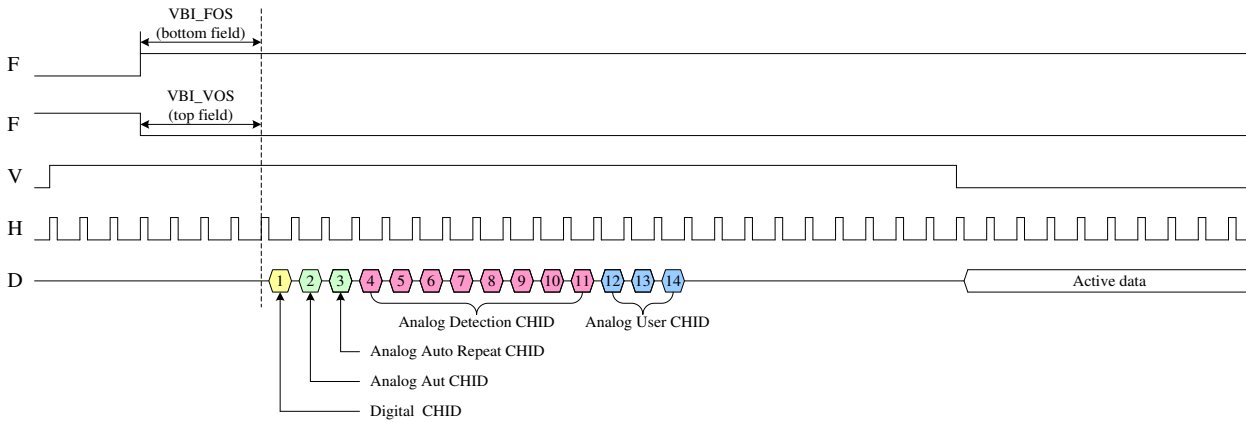

TIMING DIAGRAM OF CHANNEL ID

DIGITAL CHANNEL ID

TW2880 provides the digital type channel ID during VBI period. It's useful for DSP application because the channel ID can be inserted in just one line with special format. The digital channel ID is located before analog channel ID line. The digital channel ID can be enabled via the VIS_CODE_EN register.

The digital channel ID is inserted in Y data in BT656 or BT1120 stream and composed of ID # and channel information. The ID # indicates the index of digital type channel ID including the start code, auto/detection/user channel ID and end code. The ID number has 0 ~ 0x7F index and each channel information of one byte is divided into 2 bytes of 4 LSB that takes "0x90" offset against ID # for discrimination. The start code is located in ID# 0 ~1 and auto channel ID is situated in ID # 2 ~ 11. The detection channel ID is located in ID # 12 ~ 91 and the user channel ID is situated in ID # 92 ~ 121. The end codes occupied the others. The digital channel ID will be repeated during horizontal active period. There is no repeat auto channel ID in digital format. The following figure shows the illustration of digital channel ID.

In the TW2880 output sequence, the vertical offset of odd field is controlled by the VIS_LINE_VOS register with 1 line unit and even field is control by the VIS_LINE_FOS register with 1 line unit. Channel ID can be flexibly enabled by register VIS_ID_OEN and VIS_ID_EEN for odd field and even field respectively. These registers make it possible to insert channel ID in vertical active region if user required.

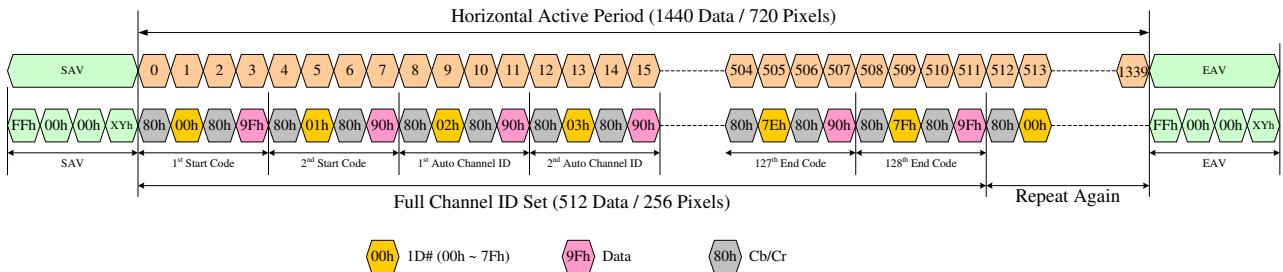

DIGITAL CHANNEL ID TIMING DIAGRAM

1D#	DATA	DESCRIPTION
0 (00h)	9Fh	Start Code
1 (01h)	90h	
2 (02h)	{9, A0_MSB}	Auto Channel ID (5x2=10 bytes)
3 (03h)	{9, A0_LSB}	
...	...	
10 (0Ah)	{9, A4_MSB}	
11 (0Bh)	{9, A4_LSB}	
12 (0Ch)	{9, D0_MSB}	Detection Channel ID (40x2=80) bytes
13 (0Dh)	{9, D0_LSB}	
...	...	
90 (5Ah)	{9, D39_MSB}	
91 (5Bh)	{9, D39_LSB}	
92 (5Ch)	{9, U0_MSB}	User Channel ID (15x2=30 bytes)
93 (5Dh)	{9, U0_LSB}	
...	...	
120 (78h)	{9, D14_MSB}	
121 (79h)	{9, D14_LSB}	
122 (7Ah)	90h	End Code
123 (7Bh)	9Fh	
124 (7Ch)	90h	End Code
125 (7Dh)	9Fh	
126 (7Eh)	90h	End Code
127 (7Fh)	9Fh	

DIGITAL CHANNEL ID DATA FORMAT

Digital channel ID data sequence is: Cb, ID#, Cr, 9Xh, Cb ID#, Cr, 9Xh, After one full set, same data must be repeated in active area.

ANALOG CHANNEL ID

TW2880 supports analog type channel ID during VBI period. The analog channel ID can include an Auto channel ID, Repeat auto channel ID, Detection channel ID and User channel ID. Each channel ID can be enabled via the VIS_AUTO_EN, AUTO_RPT_EN, VIS_DET_EN, VIS_USER_EN registers. Auto channel ID requires one line basically, but can need one more line for repetition. Detection channel ID requires 8 lines and User channel ID require three lines so that total thirteen lines are used for analog type channel ID.

Analog channel ID is located right after digital channel ID line. Default starting position is right after SAV. The horizontal starting position offset is defined via VIS_PIXEL_HOS register with 1 pixel unit for data insertion and run in clock. The vertical start point is defined via VIS_VOS for odd field and VIS_FOS is for even field in one line offset. The pixel width of each bit is controlled by the VIS_PIXEL_WIDTH register and the magnitude of each bit is defined by the VIS_HIGH_VAL and VIS_LOW_VAL register.

The analog channel ID consists of run-in clock, channel ID data, type and parity bit. The run-in clock insertion is enabled via the VIS_RIC_EN register. There are four run in clock cycles. The channel ID data can include 4 byte information and the channel ID type contains 2 bits that “0” is meant for Auto channel ID and repeated channel ID, “2” and “4” for Detection channel ID, “3” for User channel ID of VIS_MANO~5. The parity is 1 bit width and used for even parity. This definition is used for both digital and analog channel ID. There are five bytes plus 1 parity data in one line.

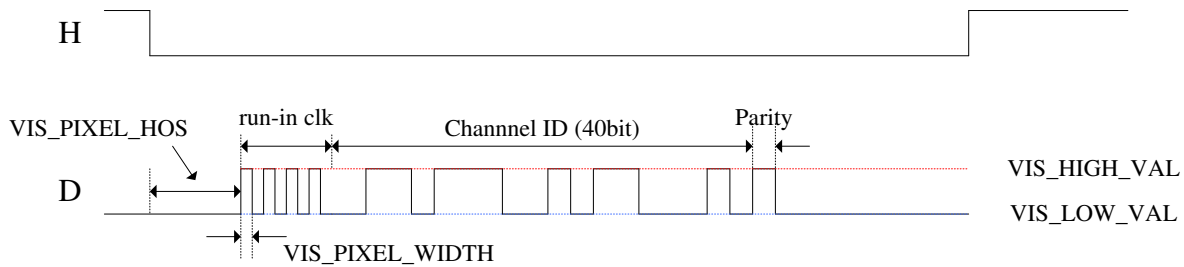

ANALOG CHANNEL ID FORMAT

In each line of analog channel ID, there are 4 run in clock cycle, 40 channel ID data cycle and 1 parity cycle. Each cycle has “VIS_PIXEL_WIDTH x 2” pixels. Analog channel ID is only located in Y position.

Channel ID in Active Region

For CODECs that do not have the capability or bandwidth to process channel ID in the vertical blanking period, TW2880 also provides a simple way to let the channels to identify themselves. The kind of channel ID is stored in the active video area in a way that is robust against horizontal and vertical scaling. To insert the channel ID, each channel will have a 2x2 luma pixel slot in the first two lines in the active region for each field. In this slot the luma value is substituted to 0x01 or the value stored in the register 0xDAF. Take next diagram for example, channel 0 will have luma pixels Y0 and Y1, channel 1 will have luma pixels Y2 and Y3, channel 2 will have luma pixels Y4 and Y5 change to 0x01 for the first two lines.

Line 0

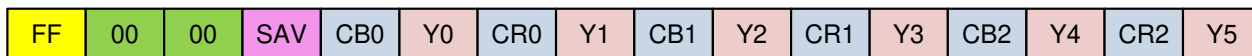

Line 1



The CODEC's firmware should recover the channel ID and replaced with a interpolated value from the adjacent pixels to minimize the impact. Next diagram illustrate the output for channel 0.

Line 0

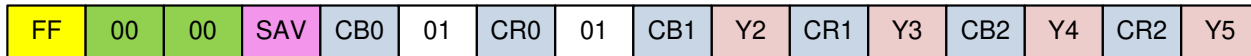

Line 1

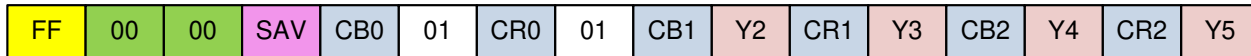

The substitution rule basically stay the same for 16 bit output. In this configuration, two adjacent luma pixels will get replaced while the chroma section is untouched. Registers 0xDAD and 0xDAE is used for limit the active channel ID only appears in the first frame of a output sequence. This is useful for the customers that already knows the output sequence of the incoming video and only want TW2880 to help identifying the first channel.

Registers Table

Address	R/W	Default	Description
0xD00	R/W	0x04	[7]: FLDMODE_PB1 [6]: INVALID_MD_PB1 [5:3]: VIN_SEL_PB1 [2:0]: VIS_PIXEL_WIDTH_PB1
0xD01	R/W	0xFF	[7]: VIS_ID_OEN_PB1 [6]: VIS_AUTO_EN_PB1 [5]: VIS_RPT_EN_PB1 [4]: VIS_DET_EN_PB1 [3]: VIS_USER_EN_PB1 [2]: VIS_CODE_EN_PB1 [1]: VIS_RIC_PB1 [0]: VIS_ID_EEN_PB1
0xD02	R/W	0x00	VIS_HOS_PB1[7:0]
0xD03	R/W	0x3F	VIS_HIGH_VAL_PB1[7:0]
0xD04	R/W	0x05	VIS_LOW_VAL_PB1[7:0]
0xD05	R/W	0x00	[4:0]: VIS_VOS_PB1
0xD06	R/W	0x00	[7:0]: VIS_MAN0_PB1_L
0xD07	R/W	0x00	[7:0]: VIS_MAN0_PB1_H
0xD08	R/W	0x00	[7:0]: VIS_MAN1_PB1_L
0xD09	R/W	0x00	[7:0]: VIS_MAN1_PB1_H
0xD0A	R/W	0x00	[7:0]: VIS_MAN2_PB1_L
0xD0B	R/W	0x00	[7:0]: VIS_MAN2_PB1_H
0xD0C	R/W	0x00	[7:0]: VIS_MAN3_PB1_L
0xD0D	R/W	0x00	[7:0]: VIS_MAN3_PB1_H
0xD0E	R/W	0x00	[7:0]: VIS_MAN4_PB1_L
0xD0F	R/W	0x00	[7:0]: VIS_MAN4_PB1_H
0xD10	R/W	0x00	[7:0]: VIS_MAN5_PB1_L
0xD11	R/W	0x00	[7:0]: VIS_MAN5_PB1_H
0xD12	R/W	0x04	[7]: FLDMODE_PB2 [6]: INVALID_MD_PB2 [5:3]: VIN_SEL_PB2 [2:0]: VIS_PIXEL_WIDTH_PB2
0xD13	R/W	0xFF	[7]: VIS_ID_OEN_PB2 [6]: VIS_AUTO_EN_PB2 [5]: VIS_RPT_EN_PB2 [4]: VIS_DET_EN_PB2 [3]: VIS_USER_EN_PB2 [2]: VIS_CODE_EN_PB2 [1]: VIS_RIC_PB2 [0]: VIS_ID_EEN_PB2
0xD14	R/W	0x00	VIS_HOS_PB2[7:0]
0xD15	R/W	0x3F	VIS_HIGH_VAL_PB2[7:0]
0xD16	R/W	0x05	VIS_LOW_VAL_PB2[7:0]
0xD17	R/W	0x00	[4:0]: VIS_VOS_PB2
0xD18	R/W	0x00	[7:0]: VIS_MAN0_PB2_L
0xD19	R/W	0x00	[7:0]: VIS_MAN0_PB2_H
0xD1A	R/W	0x00	[7:0]: VIS_MAN1_PB2_L
0xD1B	R/W	0x00	[7:0]: VIS_MAN1_PB2_H
0xD1C	R/W	0x00	[7:0]: VIS_MAN2_PB2_L
0xD1D	R/W	0x00	[7:0]: VIS_MAN2_PB2_H
0xD1E	R/W	0x00	[7:0]: VIS_MAN3_PB2_L

Address	R/W	Default	Description
0xD1F	R/W	0x00	[7:0]: VIS_MAN3_PB2_H
0xD20	R/W	0x00	[7:0]: VIS_MAN4_PB2_L
0xD21	R/W	0x00	[7:0]: VIS_MAN4_PB2_H
0xD22	R/W	0x00	[7:0]: VIS_MAN5_PB2_L
0xD23	R/W	0x00	[7:0]: VIS_MAN5_PB2_H
0xD24	R/W	0x04	[7]: FLDMODE_PB3 [6]: INVALID_MD_PB3 [5:3]: VIN_SEL_PB3 [2:0]: VIS_PIXEL_WIDTH_PB3
0xD25	R/W	0xFF	[7]: VIS_ID_OEN_PB3 [6]: VIS_AUTO_EN_PB3 [5]: VIS_RPT_EN_PB3 [4]: VIS_DET_EN_PB3 [3]: VIS_USER_EN_PB3 [2]: VIS_CODE_EN_PB3 [1]: VIS_RIC_PB3 [0]: VIS_ID_EEN_PB3
0xD26	R/W	0x00	VIS_HOS_PB3[7:0]
0xD27	R/W	0x3F	VIS_HIGH_VAL_PB3[7:0]
0xD28	R/W	0x05	VIS_LOW_VAL_PB3[7:0]
0xD29	R/W	0x00	[4:0]: VIS_VOS_PB3
0xD2A	R/W	0x00	[7:0]: VIS_MAN0_PB3_L
0xD2B	R/W	0x00	[7:0]: VIS_MAN0_PB3_H
0xD2C	R/W	0x00	[7:0]: VIS_MAN1_PB3_L
0xD2D	R/W	0x00	[7:0]: VIS_MAN1_PB3_H
0xD2E	R/W	0x00	[7:0]: VIS_MAN2_PB3_L
0xD2F	R/W	0x00	[7:0]: VIS_MAN2_PB3_H
0xD30	R/W	0x00	[7:0]: VIS_MAN3_PB3_L
0xD31	R/W	0x00	[7:0]: VIS_MAN3_PB3_H
0xD32	R/W	0x00	[7:0]: VIS_MAN4_PB3_L
0xD33	R/W	0x00	[7:0]: VIS_MAN4_PB3_H
0xD34	R/W	0x00	[7:0]: VIS_MAN5_PB3_L
0xD35	R/W	0x00	[7:0]: VIS_MAN5_PB3_H
0xD36	R/W	0x04	[7]: FLDMODE_PB4 [6]: INVALID_MD_PB4 [5:3]: VIN_SEL_PB4 [2:0]: VIS_PIXEL_WIDTH_PB4
0xD37	R/W	0xFF	[7]: VIS_ID_OEN_PB4 [6]: VIS_AUTO_EN_PB4 [5]: VIS_RPT_EN_PB4 [4]: VIS_DET_EN_PB4 [3]: VIS_USER_EN_PB4 [2]: VIS_CODE_EN_PB4 [1]: VIS_RIC_PB4 [0]: VIS_ID_EEN_PB4
0xD38	R/W	0x00	VIS_HOS_PB4[7:0]
0xD39	R/W	0x3F	VIS_HIGH_VAL_PB4[7:0]
0xD3A	R/W	0x05	VIS_LOW_VAL_PB4[7:0]
0xD3B	R/W	0x00	[4:0]: VIS_VOS_PB4
0xD3C	R/W	0x00	[7:0]: VIS_MAN0_PB4_L
0xD3D	R/W	0x00	[7:0]: VIS_MAN0_PB4_H
0xD3E	R/W	0x00	[7:0]: VIS_MAN1_PB4_L
0xD3F	R/W	0x00	[7:0]: VIS_MAN1_PB4_H
0xD40	R/W	0x00	[7:0]: VIS_MAN2_PB4_L

Address	R/W	Default	Description
0xD41	R/W	0x00	[7:0]: VIS_MAN2_PB4_H
0xD42	R/W	0x00	[7:0]: VIS_MAN3_PB4_L
0xD43	R/W	0x00	[7:0]: VIS_MAN3_PB4_H
0xD44	R/W	0x00	[7:0]: VIS_MAN4_PB4_L
0xD45	R/W	0x00	[7:0]: VIS_MAN4_PB4_H
0xD46	R/W	0x00	[7:0]: VIS_MAN5_PB4_L
0xD47	R/W	0x00	[7:0]: VIS_MAN5_PB4_H
0xD48	R/W	0x07	[7]: FLDMODE_PB5 [6]: INVALID_MD_PB5 [5:3]: VIN_SEL_PB5 [2:0]: VIS_PIXEL_WIDTH_PB5
0xD49	R/W	0xFF	[7]: VIS_ID_OEN_PB5 [6]: VIS_AUTO_EN_PB5 [5]: VIS_RPT_EN_PB5 [4]: VIS_DET_EN_PB5 [3]: VIS_USER_EN_PB5 [2]: VIS_CODE_EN_PB5 [1]: VIS_RIC_PB5 [0]: VIS_ID_EEN_PB5
0xD4A	R/W	0x00	VIS_HOS_PB5[7:0]
0xD4B	R/W	0x3F	VIS_HIGH_VAL_PB5[7:0]
0xD4C	R/W	0x05	VIS_LOW_VAL_PB5[7:0]
0xD4D	R/W	0x00	[4:0]: VIS_VOS_PB5
0xD4E	R/W	0x00	[7:0]: VIS_MAN0_PB5_L
0xD4F	R/W	0x00	[7:0]: VIS_MAN0_PB5_H
0xD50	R/W	0x00	[7:0]: VIS_MAN1_PB5_L
0xD51	R/W	0x00	[7:0]: VIS_MAN1_PB5_H
0xD52	R/W	0x00	[7:0]: VIS_MAN2_PB5_L
0xD53	R/W	0x00	[7:0]: VIS_MAN2_PB5_H
0xD54	R/W	0x00	[7:0]: VIS_MAN3_PB5_L
0xD55	R/W	0x00	[7:0]: VIS_MAN3_PB5_H
0xD56	R/W	0x00	[7:0]: VIS_MAN4_PB5_L
0xD57	R/W	0x00	[7:0]: VIS_MAN4_PB5_H
0xD58	R/W	0x00	[7:0]: VIS_MAN5_PB5_L
0xD59	R/W	0x00	[7:0]: VIS_MAN5_PB5_H
0xD5A	R/W	0x07	[7]: FLDMODE_PB6 [6]: INVALID_MD_PB6 [5:3]: VIN_SEL_PB6 [2:0]: VIS_PIXEL_WIDTH_PB6
0xD5B	R/W	0xFF	[7]: VIS_ID_OEN_PB6 [6]: VIS_AUTO_EN_PB6 [5]: VIS_RPT_EN_PB6 [4]: VIS_DET_EN_PB6 [3]: VIS_USER_EN_PB6 [2]: VIS_CODE_EN_PB6 [1]: VIS_RIC_PB6 [0]: VIS_ID_EEN_PB6
0xD5C	R/W	0x00	VIS_HOS_PB6[7:0]
0xD5D	R/W	0x3F	VIS_HIGH_VAL_PB6[7:0]
0xD5E	R/W	0x05	VIS_LOW_VAL_PB6[7:0]
0xD5F	R/W	0x00	[4:0]: VIS_VOS_PB6
0xD60	R/W	0x00	[7:0]: VIS_MAN0_PB6_L
0xD61	R/W	0x00	[7:0]: VIS_MAN0_PB6_H
0xD62	R/W	0x00	[7:0]: VIS_MAN1_PB6_L

Address	R/W	Default	Description
0xD63	R/W	0x00	[7:0]: VIS_MAN1_PB6_H
0xD64	R/W	0x00	[7:0]: VIS_MAN2_PB6_L
0xD65	R/W	0x00	[7:0]: VIS_MAN2_PB6_H
0xD66	R/W	0x00	[7:0]: VIS_MAN3_PB6_L
0xD67	R/W	0x00	[7:0]: VIS_MAN3_PB6_H
0xD68	R/W	0x00	[7:0]: VIS_MAN4_PB6_L
0xD69	R/W	0x00	[7:0]: VIS_MAN4_PB6_H
0xD6A	R/W	0x00	[7:0]: VIS_MAN5_PB6_L
0xD6B	R/W	0x00	[7:0]: VIS_MAN5_PB6_H
0xD6C	R/W	0x07	[7]: FLDMODE_PB7 [6]: INVALID_MD_PB7 [5:3]: VIN_SEL_PB7 [2:0]: VIS_PIXEL_WIDTH_PB7
0xD6D	R/W	0xFF	[7]: VIS_ID_OEN_PB7 [6]: VIS_AUTO_EN_PB7 [5]: VIS_RPT_EN_PB7 [4]: VIS_DET_EN_PB7 [3]: VIS_USER_EN_PB7 [2]: VIS_CODE_EN_PB7 [1]: VIS_RIC_PB7 [0]: VIS_ID_EEN_PB7
0xD6E	R/W	0x00	VIS_HOS_PB7[7:0]
0xD6F	R/W	0x3F	VIS_HIGH_VAL_PB7[7:0]
0xD70	R/W	0x05	VIS_LOW_VAL_PB7[7:0]
0xD71	R/W	0x00	[4:0]: VIS_VOS_PB7
0xD72	R/W	0x00	[7:0]: VIS_MAN0_PB7_L
0xD73	R/W	0x00	[7:0]: VIS_MAN0_PB7_H
0xD74	R/W	0x00	[7:0]: VIS_MAN1_PB7_L
0xD75	R/W	0x00	[7:0]: VIS_MAN1_PB7_H
0xD76	R/W	0x00	[7:0]: VIS_MAN2_PB7_L
0xD77	R/W	0x00	[7:0]: VIS_MAN2_PB7_H
0xD78	R/W	0x00	[7:0]: VIS_MAN3_PB7_L
0xD79	R/W	0x00	[7:0]: VIS_MAN3_PB7_H
0xD7A	R/W	0x00	[7:0]: VIS_MAN4_PB7_L
0xD7B	R/W	0x00	[7:0]: VIS_MAN4_PB7_H
0xD7C	R/W	0x00	[7:0]: VIS_MAN5_PB7_L
0xD7D	R/W	0x00	[7:0]: VIS_MAN5_PB7_H
0xD7E	R/W	0x07	[7]: FLDMODE_PB8 [6]: INVALID_MD_PB8 [5:3]: VIN_SEL_PB8 [2:0]: VIS_PIXEL_WIDTH_PB8
0xD7F	R/W	0xFF	[7]: VIS_ID_OEN_PB8 [6]: VIS_AUTO_EN_PB8 [5]: VIS_RPT_EN_PB8 [4]: VIS_DET_EN_PB8 [3]: VIS_USER_EN_PB8 [2]: VIS_CODE_EN_PB8 [1]: VIS_RIC_PB8 [0]: VIS_ID_EEN_PB8
0xD80	R/W	0x00	VIS_HOS_PB8[7:0]
0xD81	R/W	0x3F	VIS_HIGH_VAL_PB8[7:0]
0xD82	R/W	0x05	VIS_LOW_VAL_PB8[7:0]
0xD83	R/W	0x00	[4:0]: VIS_VOS_PB8
0xD84	R/W	0x00	[7:0]: VIS_MAN0_PB8_L

Address	R/W	Default	Description
0xD85	R/W	0x00	[7:0]: VIS_MAN0_PB8_H
0xD86	R/W	0x00	[7:0]: VIS_MAN1_PB8_L
0xD87	R/W	0x00	[7:0]: VIS_MAN1_PB8_H
0xD88	R/W	0x00	[7:0]: VIS_MAN2_PB8_L
0xD89	R/W	0x00	[7:0]: VIS_MAN2_PB8_H
0xD8A	R/W	0x00	[7:0]: VIS_MAN3_PB8_L
0xD8B	R/W	0x00	[7:0]: VIS_MAN3_PB8_H
0xD8C	R/W	0x00	[7:0]: VIS_MAN4_PB8_L
0xD8D	R/W	0x00	[7:0]: VIS_MAN4_PB8_H
0xD8E	R/W	0x00	[7:0]: VIS_MAN5_PB8_L
0xD8F	R/W	0x00	[7:0]: VIS_MAN5_PB8_H
0xD90	R/W	0x00	[4:0]: VIS_FOS_PB1
0xD91	R/W	0x00	[4:0]: VIS_FOS_PB2
0xD92	R/W	0x00	[4:0]: VIS_FOS_PB3
0xD93	R/W	0x00	[4:0]: VIS_FOS_PB4
0xD94	R/W	0x00	[4:0]: VIS_FOS_PB5
0xD95	R/W	0x00	[4:0]: VIS_FOS_PB6
0xD96	R/W	0x00	[4:0]: VIS_FOS_PB7
0xD97	R/W	0x00	[4:0]: VIS_FOS_PB8
0xD98	R/W	0x07	[7]: FLDMODE_PB9 [6]: INVALID_MD_PB9 [5:3]: VIN_SEL_PB9 [2:0]: VIS_PIXEL_WIDTH_PB9
0xD99	R/W	0xFF	[7]: VIS_ID_OEN_PB9 [6]: VIS_AUTO_EN_PB9 [5]: VIS_RPT_EN_PB9 [4]: VIS_DET_EN_PB9 [3]: VIS_USER_EN_PB9 [2]: VIS_CODE_EN_PB9 [1]: VIS_RIC_PB9 [0]: VIS_ID_EEN_PB9
0xD9A	R/W	0x00	VIS_HOS_PB9[7:0]
0xD9B	R/W	0x3F	VIS_HIGH_VAL_PB9[7:0]
0xD9C	R/W	0x05	VIS_LOW_VAL_PB9[7:0]
0xD9D	R/W	0x00	[4:0]: VIS_VOS_PB9
0xD9E	R/W	0x00	[7:0]: VIS_MAN0_PB9_L
0xD9F	R/W	0x00	[7:0]: VIS_MAN0_PB9_H
0xDA0	R/W	0x00	[7:0]: VIS_MAN1_PB9_L
0xDA1	R/W	0x00	[7:0]: VIS_MAN1_PB9_H
0xDA2	R/W	0x00	[7:0]: VIS_MAN2_PB9_L
0xDA3	R/W	0x00	[7:0]: VIS_MAN2_PB9_H
0xDA4	R/W	0x00	[7:0]: VIS_MAN3_PB9_L
0xDA5	R/W	0x00	[7:0]: VIS_MAN3_PB9_H
0xDA6	R/W	0x00	[7:0]: VIS_MAN4_PB9_L
0xDA7	R/W	0x00	[7:0]: VIS_MAN4_PB9_H
0xDA8	R/W	0x00	[7:0]: VIS_MAN5_PB9_L
0xDA9	R/W	0x00	[7:0]: VIS_MAN5_PB9_H
0xDAA	R/W	0x00	[4:0]: VIS_FOS_PB9

Address	R/W	Default	Description
0xDAB	R/W	0x00	[7]: ACTIVE_chid_EN_PB8 [6]: ACTIVE_chid_EN_PB7 [5]: ACTIVE_chid_EN_PB6 [4]: ACTIVE_chid_EN_PB5 [3]: ACTIVE_chid_EN_PB4 [2]: ACTIVE_chid_EN_PB3 [1]: ACTIVE_chid_EN_PB2 [0]: ACTIVE_chid_EN_PB1
0xDAC	R/W	0x00	[0]: ACTIVE_chid_EN_PB9
0xDAD	R/W	0x00	[7]: FIRST_FRAME_EN_P8 [6]: FIRST_FRAME_EN_P7 [5]: FIRST_FRAME_EN_P6 [4]: FIRST_FRAME_EN_P5 [3]: FIRST_FRAME_EN_P4 [2]: FIRST_FRAME_EN_P3 [1]: FIRST_FRAME_EN_P2 [0]: FIRST_FRAME_EN_P1
0xDAE	R/W	0x00	[0]: FIRST_FRAME_EN_P9
0xDAF	R/W	0x01	[0]: ACTIVE_CHID
0xDB0	R/W	0x00	[7:4]: MOTION_SEL_2 [3:0]: MOTION_SEL_1
0xDB1	R/W	0x00	[7:4]: MOTION_SEL_4 [3:0]: MOTION_SEL_3
0xDB2	R/W	0x00	[7:4]: MOTION_SEL_6 [3:0]: MOTION_SEL_5
0xDB3	R/W	0x00	[7:4]: MOTION_SEL_8 [3:0]: MOTION_SEL_7
0xDB4	R/W	0x00	[3:0]: MOTION_SEL_9
0xDB5	R/W	0x00	FLD_SEL[7:0]
0xDB6	R/W	0x00	FLD_SEL[8]

Registers Description

PB1 CHANNEL ID ENC MISC REGISTER – 0XD00

Bit	R/W	Default	Description
7	RW	0	FLDMODE_PB1: Encoder field parity 1: 1 for top field 0: 0 for top field
6	RW	0	INVALID_MD_PB1: Invalid motion detection 1: enable. CHID enc generates 0 in V and H blanking. 0: disable. CHID enc generates 0x80/0x10 in V and H blanking
5:3	RW	0	VIN_SEL_PB1: Record port selection. 0: port1 1: port2 2: port3 3: port4 4: port5 5: port6 6: port7 7: port8
2:0	RW	4	VIS_PIXEL_WIDTH_PB1 Define analog CHID data sample rate. The value is half period of data period. Unit is 1 pixel.

PB1 CHANNEL ID ENC ENABLE REGISTER – 0XD01

Bit	R/W	Default	Description
7	RW	1	VIS_ID_OEN_PB1: Enable output of D CHID and A CHID in odd field 1: enable 0: disable
6	RW	1	VIS_AUTO_EN_PB1: Enable analog auto CHID encoding. 1: enable 0: disable
5	RW	1	VIS_RPT_EN_PB1: Enable analog auto repeat CHID encoding. 1: enable 0: disable
4	RW	1	VIS_DET_EN_PB1: Enable analog detection CHID encoding. 1: enable 0: disable
3	RW	1	VIS_USER_EN_PB1: Enable analog user CHID encoding. 1: enable 0: disable
2	RW	1	VIS_CODE_EN_PB1: Enable digital CHID encoding. 1: enable 0: disable

Bit	R/W	Default	Description
1	RW	1	VIS_RIC_PB1: Enable run in clock for analog CHID 1: enable 0: disable
0	RW	1	VIS_ID_EEN_PB1: Enable output of D CHID and A CHID in even field 1: enable 0: disable

PB1 CHANNEL ID ENC HORIZONTAL OFFSET REGISTER – 0XD02

Bit	R/W	Default	Description
7:0	RW	0	VIS_HOS_PB1 Horizontal offset for analog CHID in unit of pixel.

PB1 CHANNEL ID ENC HIGH VALUE REGISTER – 0XD03

Bit	R/W	Default	Description
7:0	RW	3f	VIS_HIGH_VAL_PB1 Define high value of analog CHID data bit if it is 1.

PB1 CHANNEL ID ENC LOW VALUE REGISTER – 0XD04

Bit	R/W	Default	Description
7:0	RW	5	VIS_LOW_VAL_PB1 Define low value of analog CHID data bit if it is 0.

PB1 ODD FIELD VERTICAL LINE OFFSET REGISTER – 0XD05

Bit	R/W	Default	Description
4:0	RW	0	VIS_VOS_PB1 Vertical offset of channel ID in odd field.

PB1 CHANNEL ID ENC MAN0 LSB REGISTER – 0XD06

Bit	R/W	Default	Description
7:0	RW	0	VIS_MAN0_PB1_L User CHID.

PB1 CHANNEL ID ENC MAN0 MSB REGISTER – 0XD07

Bit	R/W	Default	Description
7:0	RW	0	VIS_MAN0_PB1_H User CHID.

PB1 CHANNEL ID ENC MAN1 LSB REGISTER – 0XD08

Bit	R/W	Default	Description
7:0	RW	0	VIS_MAN1_PB1_L User CHID.

PB1 CHANNEL ID ENC MAN1 SB REGISTER – 0XD09

Bit	R/W	Default	Description
7:0	RW	0	VIS_MAN1_PB1_H User CHID.

PB1 CHANNEL ID ENC MAN2 LSB REGISTER – 0XD0A

Bit	R/W	Default	Description
7:0	RW	0	VIS_MAN2_PB1_L User CHID.

PB1 CHANNEL ID ENC MAN2 MSB REGISTER – 0XD0B

Bit	R/W	Default	Description
7:0	RW	0	VIS_MAN2_PB1_H User CHID.

PB1 CHANNEL ID ENC MAN3 LSB REGISTER – 0XD0C

Bit	R/W	Default	Description
7:0	RW	0	VIS_MAN3_PB1_L User CHID.

PB1 CHANNEL ID ENC MAN3 MSB REGISTER – 0XD0D

Bit	R/W	Default	Description
7:0	RW	0	VIS_MAN3_PB1_H User CHID.

PB1 CHANNEL ID ENC MAN4 LSB REGISTER – 0XD0E

Bit	R/W	Default	Description
7:0	RW	0	VIS_MAN4_PB1_L User CHID.

PB1 CHANNEL ID ENC MAN4 MSB REGISTER – 0XD0F

Bit	R/W	Default	Description
7:0	RW	0	VIS_MAN4_PB1_H User CHID.

PB1 CHANNEL ID ENC MAN5 LSB REGISTER – 0XD10

Bit	R/W	Default	Description
7:0	RW	0	VIS_MAN5_PB1_L User CHID.

PB1 CHANNEL ID ENC MAN5 MSB REGISTER – 0XD11

Bit	R/W	Default	Description
7:0	RW	0	VIS_MAN5_PB1_H User CHID.

This is for record unit 1. For record unit 2 – 8, the assignments are: 0xD12 – 0xD8F, for unit 9, 0xD98 – 0xDAA

PB1 EVEN FIELD VERTICAL OFFSET REGISTER – 0XD90

Bit	R/W	Default	Description
4:0	RW	0	VIS_FOS_PB1 Vertical offset of channel ID in even field.

This is for record unit 1. For record unit 2 – 8, the assignments are: 0xD91 – 0xD97

ACTIVE AREA CHANNEL ID ENABLE REGISTER 1 – 0XDAB

Bit	R/W	Default	Description
7:0	RW	0	ACTIVE_chid_EN Simple channel ID in active area using “0x01” in first two lines [7]: ACTIVE_chid_EN_PB8 [6]: ACTIVE_chid_EN_PB7 [5]: ACTIVE_chid_EN_PB6 [4]: ACTIVE_chid_EN_PB5 [3]: ACTIVE_chid_EN_PB4 [2]: ACTIVE_chid_EN_PB3 [1]: ACTIVE_chid_EN_PB2 [0]: ACTIVE_chid_EN_PB1

ACTIVE AREA CHANNEL ID ENABLE REGISTER 2 – 0XDAC

Bit	R/W	Default	Description
0	RW	0	ACTIVE_chid_EN Simple channel ID in active area using “0x01” in first two lines [0]: ACTIVE_chid_EN_PB9

ACTIVE AREA CHANNEL ID IN FIRST FRAME REGISTER 1 – 0XDAD

Bit	R/W	Default	Description
7:0	RW	0	FIRST_FRAME_EN Active Channel ID only in first frame. [7]: FIRST_FRAME_EN_P8 [6]: FIRST_FRAME_EN_P7 [5]: FIRST_FRAME_EN_P6 [4]: FIRST_FRAME_EN_P5 [3]: FIRST_FRAME_EN_P4 [2]: FIRST_FRAME_EN_P3 [1]: FIRST_FRAME_EN_P2 [0]: FIRST_FRAME_EN_P1

ACTIVE AREA CHANNEL ID IN FIRST FRAME REGISTER 2 – 0XDAE

Bit	R/W	Default	Description
7:0	RW	0	FIRST_FRAME_EN Active Channel ID only in first frame. [0]: FIRST_FRAME_EN_P9

ACTIVE AREA CHANNEL ID DATA REGISTER – 0XDAB

Bit	R/W	Default	Description
7:0	RW	0x01	ACTIVE_CHID Active Channel ID data. If the video data is same as active channel ID data, the LSB of video data will be inverted.

MOTION CHANNEL SELECTION REGISTER – 0XDB0

Bit	R/W	Default	Description
7:4	RW	0x00	MOTION_SEL_2 This register is used for which channel motion information will be shown in 192 bit motion channel ID. It's for read out port 2.
3:0	RW	0x00	MOTION_SEL_1 This register is used for which channel motion information will be shown in 192 bit motion channel ID. It's for read out port 1.

Register 0xDB1 to 0xDB4 are for port 2 to 9

FIELD SELECTION REGISTER – 0XDB5

Bit	R/W	Default	Description
7:0	RW	0x00	FLD_SEL[7:0] This register is used for field switch mode. They are for record port 0 to 7. 0: odd field 1: even field

FIELD SELECTION REGISTER – 0XDB6

Bit	R/W	Default	Description
0	RW	0x00	FLD_SEL[8] This register is used for field switch mode. It is for network port. 0: odd field 1: even field

OSD for Recording Path

Introduction

TW2880 OSD controller for recording path displays channel information for each channel. There are 9 recording ports supported. It is a font based design. All font tables are stored in local SRAM. Channel information includes 32 characters date/time, 16 characters title and 16 characters status. There are totally 64 fonts saved in SRAM. Font width can be selected from 6, 8, 12 or 16. Font height can be selected from 8, 10, 16 or 20. Channel information is also saved in local SRAM. Besides channel information layer, there are background layer and channel boundary layer.

Features

- 9 OSD engines for 9 recording ports
- 64 fonts table saved in SRAM
- Channel information table saved in SRAM
- Three lines channel information
- 32 characters date/time
- 16 characters channel title for each channel
- 16 characters channel status for each channel
- Font size can be changed
- Channel Boundary
- Background
- Color Bar

Description

LAYERS

There are four layers including video. The bottom layer is background. Background is a pure color under video layer. Background color can be programmed. It is shown up when this channel of video is not enabled. Boundary layer is a boundary for each channel. Boundary width and color can be programmed. The top layer is channel information.

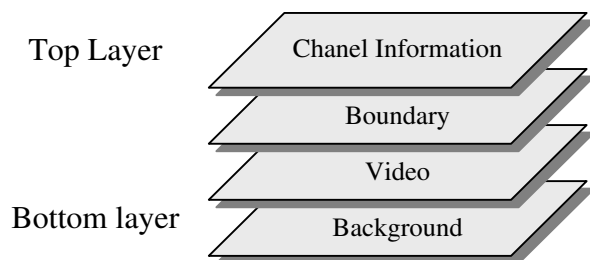

RESOLUTIONS

There are four resolutions supported: D1 (720x480 or 720x576), CIF (352x240 or 352x288), 4D1 (1440x960 or 1440x1152) and BT1120 (1920x1080). In D1 case, it can be full D1 picture, or two half D1 pictures or four quad pictures. In 4D1 case, it has 4 D1 pictures in one frame. In BT1120, it has 6 VGA pictures in one frame. Channel information picture is shown below. For each resolution, font size can be programmed.

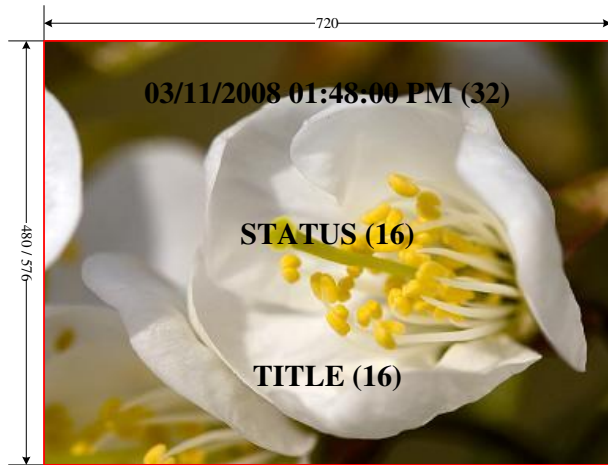

D1

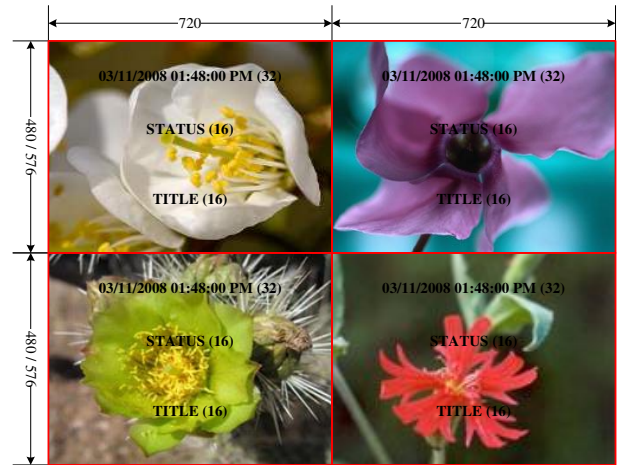

4D1

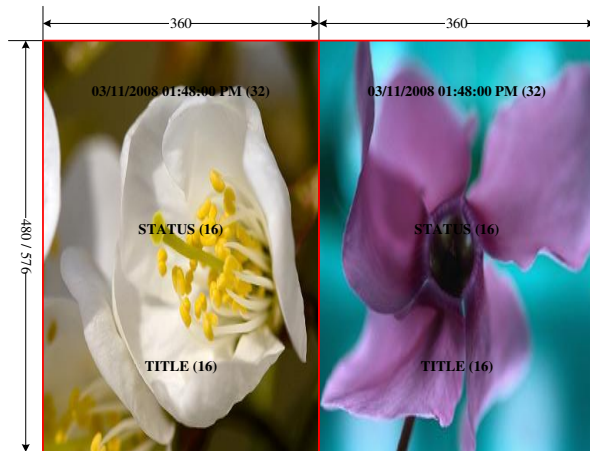

Half D1

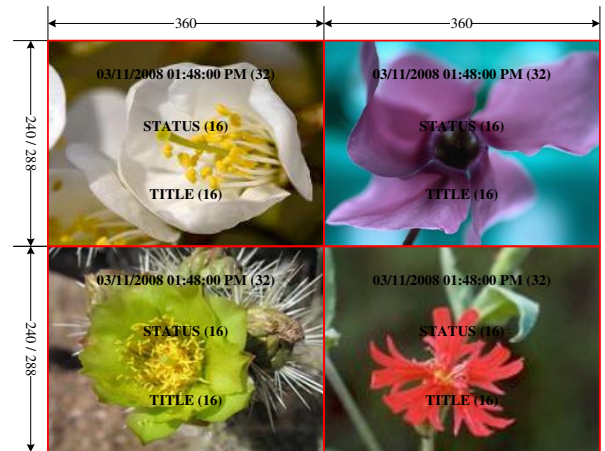

Quad

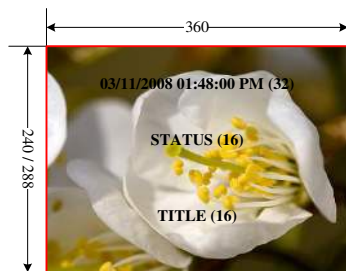

CIF

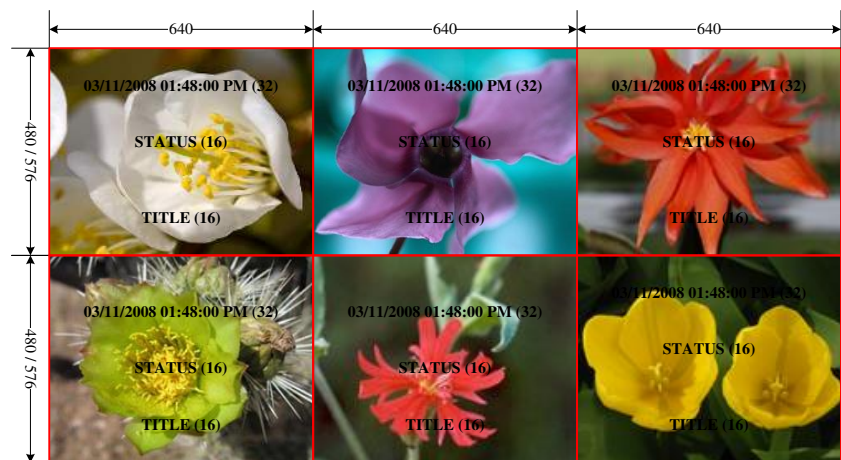

BT1120

Timing Diagram

VERTICAL TIMING

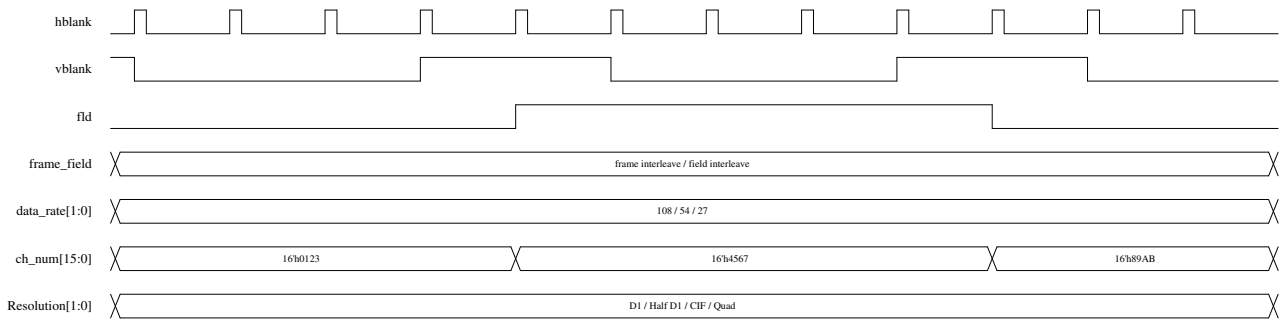

Vertical Timing

“fld” signal has different means between frame interleave and field interleave. In frame interleave, “fld” is selection for top half frame and bottom half frame. In field interleave, “fld” is selection for odd field and even field.

Channel number is 16 bits. If Quad mode is used, total 16 bits are used. [15:12] is for top left channel, [11:8] is for top right channel, [7:4] is for bottom left channel, and [3:0] is for bottom right channel. If D1 or CIF mode is selected, only bit [15:12] is used. If Half D1 mode is selected, bit [15:8] is used. [15:12] is for left channel and [11:8] is for right channel.

Resolution select different size of each channel. D1, Half D1 and Quad have same timing, but the contents in active area are different. In D1 mode, there is only one channel data. In Half D1 mode, there is two channels data. In Quad mode, there is four channels data. In CIF mode, there is only one channel but size is 1/4 of D1.

HORIZONTAL TIMING

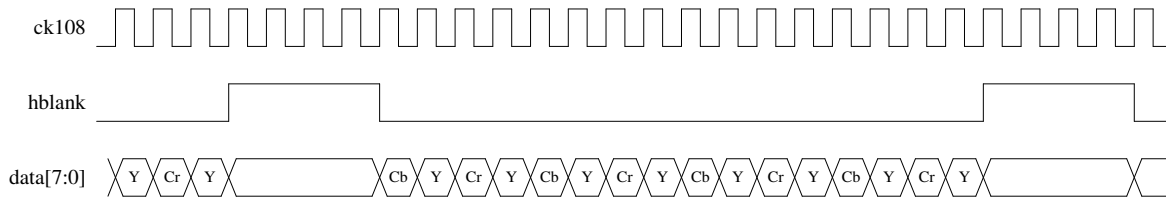

Horizontal Timing (108M)

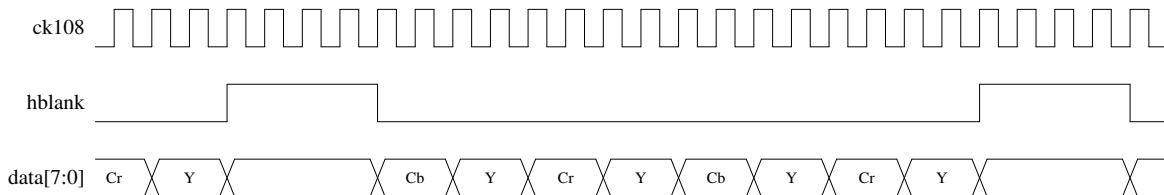

Horizontal Timing (54M)

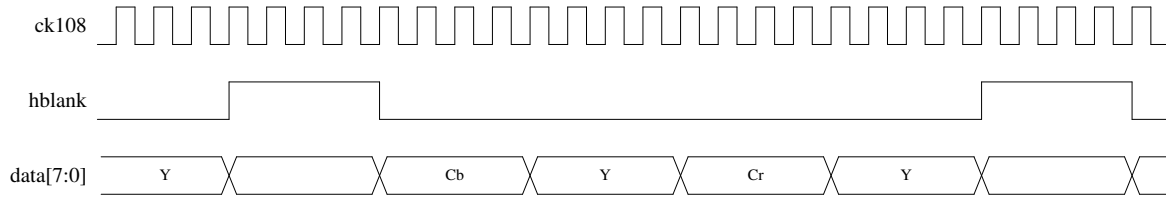

Horizontal Timing (27M)

Input clock is always 108MHz. But data rate can be select from 108MHz, 54MHz and 27MHz. Input and output data are 8 bits.

Font Composition

There are totally 64 fonts which can be saved in SRAM. The font size saved in SRAM is fixed to 8x10. But displayed font size can be changed. Horizontal can display four sizes: 6, 8, 12 or 16. Size 12 or 16 are doubled from size 6 or 8. If 6 or 12 are selected, fonts saved in SRAM must have small size. But additional two pixels must be saved in SRAM. Vertical can display four sizes: 8, 10, 16 or 20. Size 16 or 20 are doubled from size 8 or 10. If 8 or 16 are selected, fonts saved in SRAM must have small size. But additional two lines must be saved in SRAM. The following picture shows SRAM data. For 8x10 size font, all SRAM data are valid. For 6x8 size font, only 6x8 area are valid. Black area is for dummy data.

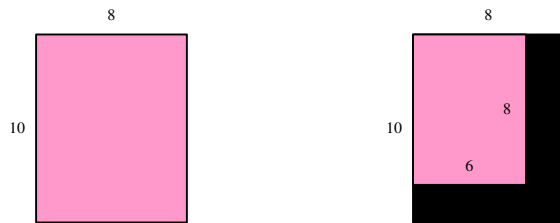

There are 2 bits for each pixel color. 00 means transparent, color 01, 10 and 11 can be set by registers: ROSD_FONT_R1 (G1, B1), ROSD_FONT_R2 (G2, B2) and ROSD_FONT_R3 (G3, B3).

Data saved in SRAM is shown below. There are totally 64x8x10*2=640x16 bits in SRAM. Data are saved font by font. For each font, data is saved line by line. Pixel data in each line is in big endian.

Different size font is used for different resolution. For example, 16x20 can be used for D1, 8x10 can be use for CIF and Quad, and 8x20 can be use for Half D1.

The font size can be changed according to register ROSD_FONT_HSIZE_* and ROSD_FONT_VSIZE_*. But remember the fonts saved in memory are always 8x10. If double size is selected, just repeat every pixel twice.

ROSD_FONT_HSIZE_FULL is for D1 mode. ROSD_FONT_HSIZE_HALF is for Half D1 and Quad and CIF mode. ROSD_FONT_VSIZE_FULL is for D1 and Half D1 mode. ROSD_FONT_VSIZE_HALF is for Quad and CIF mode.

Display Channel Information

DATE AND TIME

There are totally 32 fonts can be displayed including space. Date and time are same for each channel. The position for date and time can be programmed for different resolutions, not for channels. Each font is selected from 64-font table. So index for each font is 6 bit. Time and date can be enabled by setting register ROSD_TIME_EN and ROSD_EN to high. It can be mixed with video data by setting register ROSD_TIME_MIX to high. Mix percentage is 50% video plus 50% channel number. The font index is saved in display SRAM. It needs 32x6 bits.

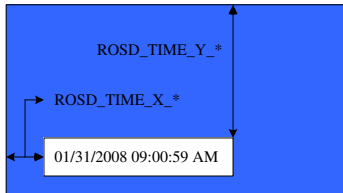

ROSD_TIME_Y_* defines vertical start position. There are three different vertical positions. ROSD_TIME_Y_FULL is for D1 and Half D1, ROSD_TIME_Y_TOP is for Quad top channels or CIF, and ROSD_TIME_Y_BOTTOM is for Quad bottom channels. All the number is based on (0,0) of whole image.

ROSD_TIME_X_* defines horizontal start position. There are three different horizontal positions. ROSD_TIME_X_FULL is for D1, ROSD_TIME_X_LEFT is for Quad left channels or CIF, and ROSD_TIME_X_RIGHT is for Quad right channels. All the number is based on (0,0) of whole image.

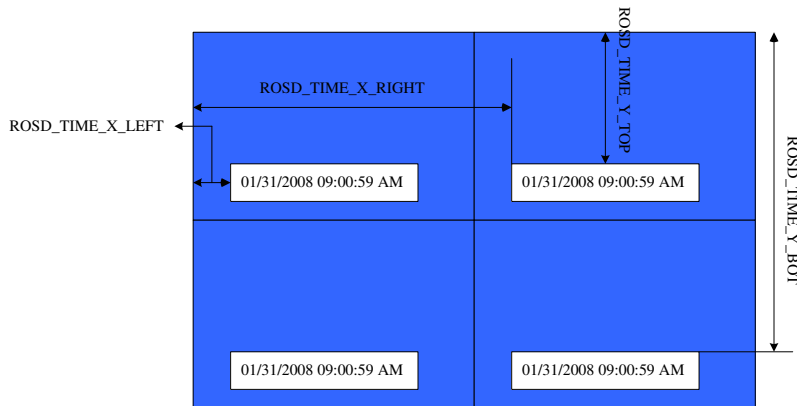

TITLE

For each channel, there is 16-font title information. Each font is selected from 64-font table. So index for each font is 6 bit. Title can be enabled by setting register ROSD_TITLE_EN and ROSD_EN to high. Title can be mixed with video data by setting register ROSD_TITLE_MIX to high. Mix percentage is 50% video plus 50% channel number. The position for date and time can be programmed for different resolutions, not for channels.

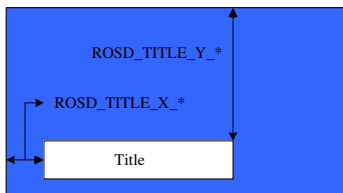

ROSD_TITLE_Y_* defines vertical start position. There are three different vertical positions. ROSD_TITLE_Y_FULL is for D1 and Half D1, ROSD_TITLE_Y_TOP is for Quad top channels or CIF, and ROSD_TITLE_Y_BOTTOM is for Quad bottom channels.

ROSD_TITLE_X_* defines horizontal start position. There are three different horizontal positions. **ROSD_TITLE_X_FULL** is for D1, **ROSD_TITLE_X_LEFT** is for Quad left channels or CIF, and **ROSD_TITLE_X_RIGHT** is for Quad right channels.

If channel number information has less than 16 fonts, you can set the remaining font to space. So you need to put space font in the 64-font table.

Channel information for display is saved in display SRAM. It contains $16 \times 6 \times 16 = 256 \times 6$. The sequence is channel by channel. In each channel, the sequence is font by font.

STATUS

Status is same as title. It has 16 fonts. It needs $16 \times 6 \times 16$ bit SRAM size.

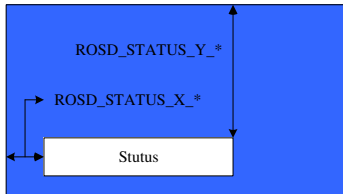

SRAM Allocation

There are two SRAM blocks in this design. One is for font. The other is for display information.

FONT SRAM

Fonts are saved in one SRAM block. Font SRAM size is 640×16 bits.

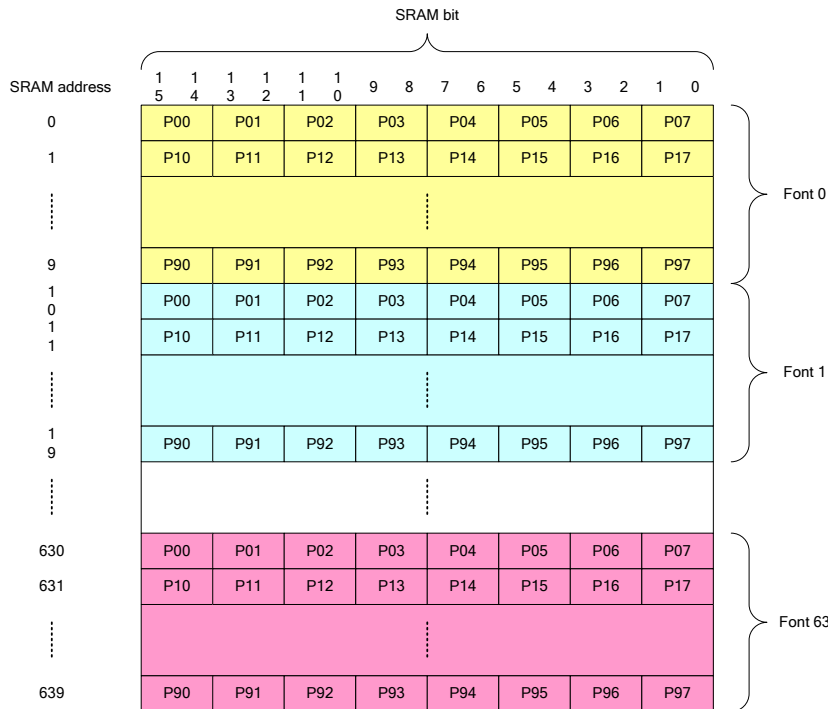

During system initialization, host need to write font data in this SRAM. The write sequence is:

1. **ROSD_FRAM_ADDR[7:0]**
2. **ROSD_FRAM_ADDR[10:0]**

3. ROSD_FRAM_DATA[7:0]

4. ROSD_FRAM_DATA[15:8]

ROSD_FRAM_DATA[15:8] must be the last one.

DISPLAY SRAM

Display SRAM includes time and date, channel title and status. Time and date needs 32x6 bits, channel title needs 256x6 bits, and channel status needs 256x16 bits also. So the total SRAM size is 544x6 bits.

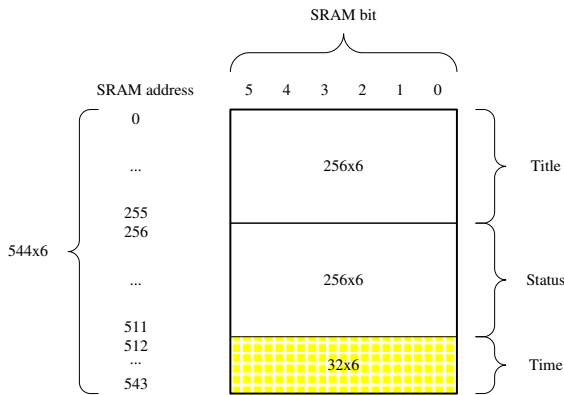

During display, host need to write index data in this SRAM. The write sequence is:

Set ROSD_DRAM_ADDR, and then set ROSD_DRAM_DATA.

Privacy Windows

This feature is used to provide privacies for the monitored objects. In many occasions we need to provide options to block certain private information from the monitoring people. Take monitoring banking ATMs in the shopping mall for example, although we want to monitor the overall operations and the activities for this object to prevent any malpractice, we want to protect the customers PIDs to be recorded and made public later on. To achieve this, system providers can use the privacy windows offered by TW2880 to block these kind of hot spots and make sure no one else get access to customers' code.

There are actually three sets of independent privacy window in the TW2880. One for live video (dual monitor is controlled by the same set), one for SPOT and one for record. To simplify the control of these three sets, we have shadowed the three sets under the control of register 0xE4F bit 1 and 0. 0x00 will control the reading and writing of the recording privacy windows, 0x01 will control the SPOT window set and 0x10 will control live window set. To read / write the respective register sets you need to put proper values to these two bits first.

INTRODUCTION

There are four windows in each channel for each set so altogether there are 192 windows to play with. To use these windows, user needs to program the horizontal start, vertical start, horizontal size, vertical size and effect that you desired and enable the window, you will see portion of the image is affected by the window.

The unit for horizontal start is double pixel, with the 8 bit provided you can cover the whole horizontal span. Same thing for the vertical except the unit is double line and the control bit is 7 bit. For the window size TW2880 provides 8 horizontal selections and four vertical selections for the users.

MASKING EFFECT

8 masking effects are provided including mosaic. Except the two solid color masks which users can not see anything under the mask, the rest effects are provided to let monitoring people see the some of the actions but cannot see the details of the operation hence the privacy protection. The "over exposed" and "under exposed"

masks are generated by playing the luminance values of the pixels that are under the window boundaries. The “over exposed” mask is generated by adding a pre-defined value to every pixel’s luminance value within the window and go through a limiter. The “under exposed” mask is generated by dividing a fixed value to every pixels under the window. The values and the factors are selectable.

MOSAIC EFFECT

4 Mosaic sizes are provided, they are 8x8, 16x16, 32x32 and 64x64. Take 16x16 size for example, this will divide a NTSC field into a 45x15 cell. (45x18 for PAL). If mosaic effect is turn on, every pixel inside the cell will have the same luminance value. Visually, this will create a tiled cell array such that any detailed information underneath the window is impossible to see through. Smaller sizes of mosaic tile is used to block detailed movement but let the observer see the general motion.



Original Video Image



White Mask Image



Black Mask Image

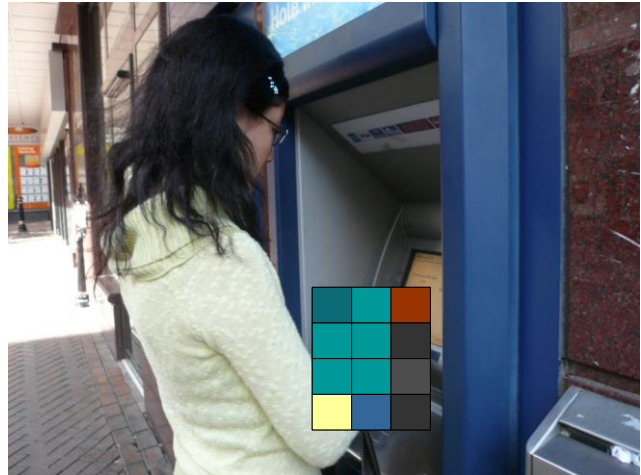

Mosaic Mask Image

Registers Table

Address	R/W	Default	Description
0xE00	R/W	0	[7]: ROSD_EN8 [6]: ROSD_EN7 [5]: ROSD_EN6 [4]: ROSD_EN5 [3]: ROSD_EN4 [2]: ROSD_EN3 [1]: ROSD_EN2 [0]: ROSD_EN1
0xE01	R/W	0	[7]: ROSD_TIME_EN8 [6]: ROSD_TIME_EN7 [5]: ROSD_TIME_EN6 [4]: ROSD_TIME_EN5 [3]: ROSD_TIME_EN4 [2]: ROSD_TIME_EN3 [1]: ROSD_TIME_EN2 [0]: ROSD_TIME_EN1
0xE02	R/W	0	[7]: ROSD_TITLE_EN8 [6]: ROSD_TITLE_EN7 [5]: ROSD_TITLE_EN6 [4]: ROSD_TITLE_EN5 [3]: ROSD_TITLE_EN4 [2]: ROSD_TITLE_EN3 [1]: ROSD_TITLE_EN2 [0]: ROSD_TITLE_EN1
0xE03	R/W	0	[7]: ROSD_STATUS_EN8 [6]: ROSD_STATUS_EN7 [5]: ROSD_STATUS_EN6 [4]: ROSD_STATUS_EN5 [3]: ROSD_STATUS_EN4 [2]: ROSD_STATUS_EN3 [1]: ROSD_STATUS_EN2 [0]: ROSD_STATUS_EN1
0xE04	R/W	0	[7]: ROSD_BNDRY_EN8 [6]: ROSD_BNDRY_EN7 [5]: ROSD_BNDRY_EN6 [4]: ROSD_BNDRY_EN5 [3]: ROSD_BNDRY_EN4 [2]: ROSD_BNDRY_EN3 [1]: ROSD_BNDRY_EN2 [0]: ROSD_BNDRY_EN1
0xE05	R/W	0	[7]: ROSD_BGND_EN8 [6]: ROSD_BGND_EN7 [5]: ROSD_BGND_EN6 [4]: ROSD_BGND_EN5 [3]: ROSD_BGND_EN4 [2]: ROSD_BGND_EN3 [1]: ROSD_BGND_EN2 [0]: ROSD_BGND_EN1

Address	R/W	Default	Description
0xE06	R/W	0	[7]: ROSD_MIX_8 [6]: ROSD_MIX_7 [5]: ROSD_MIX_6 [4]: ROSD_MIX_5 [3]: ROSD_MIX_4 [2]: ROSD_MIX_3 [1]: ROSD_MIX_2 [0]: ROSD_MIX_1
0xE07	R/W	0x2	[3:0]: ROSD_BNDRY_WIDTH[3:0]
0xE08	R/W	0x77	[7:6]: ROSD_FONT_VSIZE_HALF [5:4]: ROSD_FONT_VSIZE_FULL [3:2]: ROSD_FONT_HSIZE_HALF [1:0]: ROSD_FONT_HSIZE_FULL
0xE09	R/W	0	ROSD_TIME_X_FULL[7:0]
0xE0A	R/W	0	ROSD_TIME_X_FULL[9:8]
0xE0B	R/W	0	ROSD_TIME_X_LEFT[7:0]
0xE0C	R/W	0	ROSD_TIME_X_LEFT[9:8]
0xE0D	R/W	0	ROSD_TIME_X_RIGHT[7:0]
0xE0E	R/W	0	ROSD_TIME_X_RIGHT[9:8]
0xE0F	R/W	0	ROSD_TIME_Y_FULL[7:0]
0xE10	R/W	0	ROSD_TIME_Y_FULL[9:8]
0xE11	R/W	0	ROSD_TIME_Y_TOP[7:0]
0xE12	R/W	0	ROSD_TIME_Y_TOP[9:8]
0xE13	R/W	0	ROSD_TIME_Y_BOTTOM[7:0]
0xE14	R/W	0	ROSD_TIME_Y_BOTTOM[9:8]
0xE15	R/W	0	ROSD_TITLE_X_FULL[7:0]
0xE16	R/W	0	ROSD_TITLE_X_FULL[9:8]
0xE17	R/W	0	ROSD_TITLE_X_LEFT[7:0]
0xE18	R/W	0	ROSD_TITLE_X_LEFT[9:8]
0xE19	R/W	0	ROSD_TITLE_X_RIGHT[7:0]
0xE1A	R/W	0	ROSD_TITLE_X_RIGHT[9:8]
0xE1B	R/W	0	ROSD_TITLE_Y_FULL[7:0]
0xE1C	R/W	0	ROSD_TITLE_Y_FULL[9:8]
0xE1D	R/W	0	ROSD_TITLE_Y_TOP[7:0]
0xE1E	R/W	0	ROSD_TITLE_Y_TOP[9:8]
0xE1F	R/W	0	ROSD_TITLE_Y_BOTTOM[7:0]
0xE20	R/W	0	ROSD_TITLE_Y_BOTTOM[9:8]
0xE21	R/W	0	ROSD_STATUS_X_FULL[7:0]
0xE22	R/W	0	ROSD_STATUS_X_FULL[9:8]
0xE23	R/W	0	ROSD_STATUS_X_LEFT[7:0]
0xE24	R/W	0	ROSD_STATUS_X_LEFT[9:8]
0xE25	R/W	0	ROSD_STATUS_X_RIGHT[7:0]
0xE26	R/W	0	ROSD_STATUS_X_RIGHT[9:8]
0xE27	R/W	0	ROSD_STATUS_Y_FULL[7:0]
0xE28	R/W	0	ROSD_STATUS_Y_FULL[9:8]
0xE29	R/W	0	ROSD_STATUS_Y_TOP[7:0]
0xE2A	R/W	0	ROSD_STATUS_Y_TOP[9:8]
0xE2B	R/W	0	ROSD_STATUS_Y_BOTTOM[7:0]
0xE2C	R/W	0	ROSD_STATUS_Y_BOTTOM[9:8]
0xE2D	R/W	0x10	ROSD_FONT_Y1[7:0]
0xE2E	R/W	0x80	ROSD_FONT_CB1[7:0]
0xE2F	R/W	0x80	ROSD_FONT_CR1[7:0]
0xE30	R/W	0x10	ROSD_FONT_Y2[7:0]

Address	R/W	Default	Description
0xE31	R/W	0x80	ROSD_FONT_CB2[7:0]
0xE32	R/W	0x80	ROSD_FONT_CR2[7:0]
0xE33	R/W	0x10	ROSD_FONT_Y3[7:0]
0xE34	R/W	0x80	ROSD_FONT_CB3[7:0]
0xE35	R/W	0x80	ROSD_FONT_CR3[7:0]
0xE36	R/W	0x10	ROSD_BGND_Y[7:0]
0xE37	R/W	0x80	ROSD_BGND_CB[7:0]
0xE38	R/W	0x80	ROSD_BGND_CR[7:0]
0xE39	R/W	0x10	ROSD_BNDRY_Y[7:0]
0xE3A	R/W	0x80	ROSD_BNDRY_CB[7:0]
0xE3B	R/W	0x80	ROSD_BNDRY_CR[7:0]
0xE3C	W	0	ROSD_FRAM_ADDR[7:0]
0xE3D	W	0	ROSD_FRAM_ADDR[9:8]
0xE3E	W	0	ROSD_FRAM_DATA[7:0]
0xE3F	W	0	ROSD_FRAM_DATA[15:8]
0xE40	W	0	ROSD_DRAM_ADDR[7:0]
0xE41	W	0	ROSD_DRAM_ADDR[9:8]
0xE42	W	0	ROSD_DRAM_DATA[5:0]
0xE43	R/W	0	[7]: ROSD_COLBAR_EN8 [6]: ROSD_COLBAR_EN7 [5]: ROSD_COLBAR_EN6 [4]: ROSD_COLBAR_EN5 [3]: ROSD_COLBAR_EN4 [2]: ROSD_COLBAR_EN3 [1]: ROSD_COLBAR_EN2 [0]: ROSD_COLBAR_EN1
0xE44	R/W	0	[7]: ROSD_COLBAR_EN9 [6]: ROSD_MIX_9 [5]: ROSD_BGND_EN9 [4]: ROSD_BNDRY_EN9 [3]: ROSD_STATUS_EN9 [2]: ROSD_TITLE_EN9 [1]: ROSD_TIME_EN9 [0]: ROSD_EN9
0xE45	R/W	0	ROSD_COLBAR_VPOS[7:0]
0xE46	R/W	0	ROSD_FSWITCH[7:0]
0xE47	R/W	0	Privacy Window Overflow Register 1 for window 1
0xE48	R/W	0	Privacy Window Overflow Register 2 for window 1
0xE49	R/W	0	Privacy Window Overflow Register 1 for window 2
0xE4A	R/W	0	Privacy Window Overflow Register 2 for window 2
0xE4B	R/W	0	Privacy Window Overflow Register 1 for window 3
0xE4C	R/W	0	Privacy Window Overflow Register 2 for window 3
0xE4D	R/W	0	Privacy Window Overflow Register 1 for window 4
0xE4E	R/W	0	Privacy Window Overflow Register 2 for window 4
0xE4F	R/W	0	Privacy Window Shadow Set Control Register
0xE50-0xE5F	R/W	0	Privacy Window 1 Horizontal Start Register
0xE60-0xE6F	R/W	0	Privacy Window 1 Vertical Start Register
0xE70-0xE7F	R/W	0	Privacy Window 1 Control Register
0xE80-0xE8F	R/W	0	Privacy Window 2 Horizontal Start Register
0xE90-0xE9F	R/W	0	Privacy Window 2 Vertical Start Register
0xEA0-0xEAF	R/W	0	Privacy Window 2 Control Register
0xEB0-0xEBF	R/W	0	Privacy Window 3 Horizontal Start Register
0xEC0-0xECF	R/W	0	Privacy Window 3 Vertical Start Register

Address	R/W	Default	Description
0xED0-0xEDF	R/W	0	Privacy Window 3 Control Register
0xDD0-0xDDF	R/W	0	Privacy Window 4 Horizontal Start Register
0xDE0-0xDEF	R/W	0	Privacy Window 4 Vertical Start Register
0xDF0-0xDFE	R/W	0	Privacy Window 4 Control Register

Registers Description

ROSD ENABLE REGISTER – 0XE00

Bit	R/W	Default	Description
7:0	RW	0	<p>ROSD_EN</p> <p>[7]: ROSD_EN8 [6]: ROSD_EN7 [5]: ROSD_EN6 [4]: ROSD_EN5 [3]: ROSD_EN4 [2]: ROSD_EN3 [1]: ROSD_EN2 [0]: ROSD_EN1</p> <p>Recording port n (1 to 8) OSD enable or disable. If this register is set to 1, OSD is enabled. But you need to set ROSD_TIME_EN or ROSD_TITLE_EN or ROSD_STATUS_EN if needed. If ROSD_EN is set to 0, all ROSD display is disabled.</p>

ROSD TIME AND DATE ENABLE REGISTER – 0XE01

Bit	R/W	Default	Description
7:0	RW	0	<p>ROSD_TIME_EN</p> <p>[7]: ROSD_TIME_EN8 [6]: ROSD_TIME_EN7 [5]: ROSD_TIME_EN6 [4]: ROSD_TIME_EN5 [3]: ROSD_TIME_EN4 [2]: ROSD_TIME_EN3 [1]: ROSD_TIME_EN2 [0]: ROSD_TIME_EN1</p> <p>Recording port n (1 to 8) time and date enable or disable. To enable time and date, you need to set ROSD_EN and ROSD_TIME_EN.</p>

ROSD TITLE ENABLE REGISTER – 0XE02

Bit	R/W	Default	Description
7:0	RW	0	<p>ROSD_TITLE_EN</p> <p>[7]: ROSD_TITLE_EN8 [6]: ROSD_TITLE_EN7 [5]: ROSD_TITLE_EN6 [4]: ROSD_TITLE_EN5 [3]: ROSD_TITLE_EN4 [2]: ROSD_TITLE_EN3 [1]: ROSD_TITLE_EN2 [0]: ROSD_TITLE_EN1</p> <p>Recording port n (1 to 8) title enable or disable. To enable title, you need to set ROSD_EN and ROSD_TITLE_EN.</p>

ROSD STATUS ENABLE REGISTER – 0XE03

Bit	R/W	Default	Description
7:0	RW	0	<p>ROSD_STATUS_EN</p> <p>[7]: ROSD_STATUS_EN8 [6]: ROSD_STATUS_EN7 [5]: ROSD_STATUS_EN6 [4]: ROSD_STATUS_EN5 [3]: ROSD_STATUS_EN4 [2]: ROSD_STATUS_EN3 [1]: ROSD_STATUS_EN2 [0]: ROSD_STATUS_EN1</p> <p>Recording port n (1 to 8) status enable or disable. To enable status, you need to set ROSD_EN and ROSD_STATUS_EN.</p>

ROSD BOUNDARY ENABLE REGISTER – 0XE04

Bit	R/W	Default	Description
7:0	RW	0	<p>ROSD_BNDRY_EN</p> <p>[7]: ROSD_BNDRY_EN8 [6]: ROSD_BNDRY_EN7 [5]: ROSD_BNDRY_EN6 [4]: ROSD_BNDRY_EN5 [3]: ROSD_BNDRY_EN4 [2]: ROSD_BNDRY_EN3 [1]: ROSD_BNDRY_EN2 [0]: ROSD_BNDRY_EN1</p> <p>Recording port n (1 to 8) boundary enable or disable. To enable boundary, you need to set ROSD_EN and ROSD_BNDRY_EN.</p>

ROSD BACKGROUND ENABLE REGISTER – 0XE05

Bit	R/W	Default	Description
7:0	RW	0	<p>ROSD_BGND_EN</p> <p>[7]: ROSD_BGND_EN8 [6]: ROSD_BGND_EN7 [5]: ROSD_BGND_EN6 [4]: ROSD_BGND_EN5 [3]: ROSD_BGND_EN4 [2]: ROSD_BGND_EN3 [1]: ROSD_BGND_EN2 [0]: ROSD_BGND_EN1</p> <p>Recording port n (1 to 8) back ground enable or disable. To enable back ground, you need to set ROSD_EN and ROSD_BGND_EN.</p>

ROSD MIX CONTROL ENABLE REGISTER – 0XE06

Bit	R/W	Default	Description
7:0	RW	0	<p>ROSD_MIX</p> <p>[7]: ROSD_MIX_8 [6]: ROSD_MIX_7 [5]: ROSD_MIX_6 [4]: ROSD_MIX_5 [3]: ROSD_MIX_4 [2]: ROSD_MIX_3 [1]: ROSD_MIX_2 [0]: ROSD_MIX_1</p> <p>Display font mix enable bit. If set to 1, font data will be 50% blending with video 1: enable 0: disable</p>

ROSD BOUNDARY WIDTH REGISTER – 0XE07

Bit	R/W	Default	Description
3:0	RW	2	<p>ROSD_BNDRY_WIDTH</p> <p>Boundary width from 0 to 15. Unit is 2 pixels. Only Quad has boundary.</p>

ROSD FONT SIZE REGISTER – 0XE08

Bit	R/W	Default	Description
7:6	RW	1	<p>ROSD_FONT_VSIZE_HALF</p> <p>Font vertical size for Quad and CIF mode. There are four choices. 00: 8 01: 10 10: 16, scale up from 8 11: 20, scale up from 10</p>
5:4	RW	3	<p>ROSD_FONT_VSIZE_FULL</p> <p>Font vertical size for D1 and half D1 mode. There are four choices. 00: 8 01: 10 10: 16, scale up from 8 11: 20, scale up from 10</p>
3:2	RW	1	<p>ROSD_FONT_HSIZE_HALF</p> <p>Font horizontal size for Quad, half D1 and CIF mode. There are four choices. 00: 6 01: 8 10: 12, scale up from 6 11: 16, scale up from 8</p>

Bit	R/W	Default	Description
1:0	RW	1	ROSD_FONT_HSIZE_FULL Font horizontal size for D1 mode. There are four choices. 00: 6 01: 8 10: 12, scale up from 6 11: 16, scale up from 8

ROSD TIME HORIZONTAL POSTION FOR FULL MODE LOW BYTE REGISTER – 0XE09

Bit	R/W	Default	Description
7:0	RW	0	ROSD_TIME_X_FULL[7:0] Time and Date horizontal position for D1 mode. Unit is 1 pixel

ROSD TIME HORIZONTAL POSTION FOR FULL MODE HIGH BYTE REGISTER – 0XE0A

Bit	R/W	Default	Description
1:0	RW	0	ROSD_TIME_X_FULL[9:8] Time and Date horizontal position for D1 mode. Unit is 1 pixel

ROSD TIME HORIZONTAL LEFT POSTION FOR HALF MODE LOW BYTE REGISTER – 0XE0B

Bit	R/W	Default	Description
7:0	RW	0	ROSD_TIME_X_LEFT[7:0] Time and Date horizontal left position for half D1, Quad and CIF mode. Unit is 1 pixel

ROSD TIME HORIZONTAL LEFT POSTION FOR HALF MODE HIGH BYTE REGISTER – 0XE0C

Bit	R/W	Default	Description
1:0	RW	0	ROSD_TIME_X_LEFT[9:8] Time and Date horizontal left position for half D1, Quad and CIF mode. Unit is 1 pixel

ROSD TIME HORIZONTAL RIGHT POSTION FOR HALF MODE LOW BYTE REGISTER – 0XE0D

Bit	R/W	Default	Description
7:0	RW	0	ROSD_TIME_X_RIGHT[7:0] Time and Date horizontal right position for half D1, Quad and CIF mode. Unit is 1 pixel

ROSD TIME HORIZONTAL RIGHT POSTION FOR HALF MODE HIGH BYTE REGISTER – 0XE0E

Bit	R/W	Default	Description
1:0	RW	0	ROSD_TIME_X_RIGHT[9:8] Time and Date horizontal right position for half D1, Quad and CIF mode. Unit is 1 pixel

ROSD TIME VERTICAL POSTION FOR FULL MODE LOW BYTE REGISTER – 0XE0F

Bit	R/W	Default	Description
7:0	RW	0	ROSD_TIME_Y_FULL[7:0] Time and Date vertical position for D1 and half D1 mode. Unit is 1 pixel

ROSD TIME VERTICAL POSTION FOR FULL MODE HIGH BYTE REGISTER – 0XE10

Bit	R/W	Default	Description
1:0	RW	0	ROSD_TIME_Y_FULL[9:8] Time and Date vertical position for D1 and half D1 mode. Unit is 1 pixel

ROSD TIME VERTICAL TOP POSTION FOR HALF MODE LOW BYTE REGISTER – 0XE11

Bit	R/W	Default	Description
7:0	RW	0	ROSD_TIME_Y_TOP[7:0] Time and Date vertical top position for Quad and CIF mode. Unit is 1 pixel

ROSD TIME VERTICAL TOP POSTION FOR HALF MODE HIGH BYTE REGISTER – 0XE12

Bit	R/W	Default	Description
1:0	RW	0	ROSD_TIME_Y_TOP[9:8] Time and Date vertical top position for Quad and CIF mode. Unit is 1 pixel

ROSD TIME VERTICAL BOTTOM POSTION FOR HALF MODE LOW BYTE REGISTER – 0XE13

Bit	R/W	Default	Description
7:0	RW	0	ROSD_TIME_Y_BOTTOM[7:0] Time and Date vertical bottom position for Quad and CIF mode. Unit is 1 pixel

ROSD TIME VERTICAL BOTTOM POSTION FOR HALF MODE HIGH BYTE REGISTER – 0XE14

Bit	R/W	Default	Description
1:0	RW	0	ROSD_TIME_Y_BOTTOM[9:8] Time and Date vertical bottom position for Quad and CIF mode. Unit is 1 pixel

ROSD TITLE HORIZONTAL POSTION FOR FULL MODE LOW BYTE REGISTER – 0XE15

Bit	R/W	Default	Description
7:0	RW	0	ROSD_TITLE_X_FULL[7:0] Title horizontal position for D1 mode. Unit is 1 pixel

ROSD TITLE HORIZONTAL POSTION FOR FULL MODE HIGH BYTE REGISTER – 0XE16

Bit	R/W	Default	Description
1:0	RW	0	ROSD_TITLE_X_FULL[9:8] Title horizontal position for D1 mode. Unit is 1 pixel

ROSD TITLE HORIZONTAL LEFT POSTION FOR HALF MODE LOW BYTE REGISTER – 0XE17

Bit	R/W	Default	Description
7:0	RW	0	ROSD_TITLE_X_LEFT[7:0] Title horizontal left position for half D1, Quad and CIF mode. Unit is 1 pixel

ROSD TITLE HORIZONTAL LEFT POSTION FOR HALF MODE HIGH BYTE REGISTER – 0XE18

Bit	R/W	Default	Description
1:0	RW	0	ROSD_TITLE_X_LEFT[9:8] Title horizontal left position for half D1, Quad and CIF mode. Unit is 1 pixel

ROSD TITLE HORIZONTAL RIGHT POSTION FOR HALF MODE LOW BYTE REGISTER – 0XE19

Bit	R/W	Default	Description
7:0	RW	0	ROSD_TITLE_X_RIGHT[7:0] Title horizontal right position for half D1, Quad and CIF mode. Unit is 1 pixel

ROSD TITLE HORIZONTAL RIGHT POSTION FOR HALF MODE HIGH BYTE REGISTER – 0XE1A

Bit	R/W	Default	Description
1:0	RW	0	ROSD_TITLE_X_RIGHT[9:8] Title horizontal right position for half D1, Quad and CIF mode. Unit is 1 pixel

ROSD TITLE VERTICAL POSTION FOR FULL MODE LOW BYTE REGISTER – 0XE1B

Bit	R/W	Default	Description
7:0	RW	0	ROSD_TITLE_Y_FULL[7:0] Title vertical position for D1 and half D1 mode. Unit is 1 pixel

ROSD TITLE VERTICAL POSTION FOR FULL MODE HIGH BYTE REGISTER – 0XE1C

Bit	R/W	Default	Description
1:0	RW	0	ROSD_TITLE_Y_FULL[9:8] Title vertical position for D1 and half D1 mode. Unit is 1 pixel

ROSD TITLE VERTICAL TOP POSTION FOR HALF MODE LOW BYTE REGISTER – 0XE1D

Bit	R/W	Default	Description
7:0	RW	0	ROSD_TITLE_Y_TOP[7:0] Title vertical top position for Quad and CIF mode. Unit is 1 pixel

ROSD TITLE VERTICAL TOP POSTION FOR HALF MODE HIGH BYTE REGISTER – 0XE1E

Bit	R/W	Default	Description
1:0	RW	0	ROSD_TITLE_Y_TOP[9:8] Title vertical top position for Quad and CIF mode. Unit is 1 pixel

ROSD TITLE VERTICAL BOTTOM POSTION FOR HALF MODE LOW BYTE REGISTER – 0XE1F

Bit	R/W	Default	Description
7:0	RW	0	ROSD_TITLE_Y_BOTTOM[7:0] Title vertical bottom position for Quad and CIF mode. Unit is 1 pixel

ROSD TITLE VERTICAL BOTTOM POSTION FOR HALF MODE HIGH BYTE REGISTER – 0XE20

Bit	R/W	Default	Description
1:0	RW	0	ROSD_TITLE_Y_BOTTOM[9:8] Title vertical bottom position for Quad and CIF mode. Unit is 1 pixel

ROSD STATUS HORIZONTAL POSTION FOR FULL MODE LOW BYTE REGISTER – 0XE21

Bit	R/W	Default	Description
7:0	RW	0	ROSD_STATUS_X_FULL[7:0] Status horizontal position for D1 mode. Unit is 1 pixel

ROSD STATUS HORIZONTAL POSTION FOR FULL MODE HIGH BYTE REGISTER – 0XE22

Bit	R/W	Default	Description
1:0	RW	0	ROSD_STATUS_X_FULL[9:8] Status horizontal position for D1 mode. Unit is 1 pixel

ROSD STATUS HORIZONTAL LEFT POSTION FOR HALF MODE LOW BYTE REGISTER – 0XE23

Bit	R/W	Default	Description
7:0	RW	0	ROSD_STATUS_X_LEFT[7:0] Status horizontal left position for half D1, Quad and CIF mode. Unit is 1 pixel

ROSD STATUS HORIZONTAL LEFT POSTION FOR HALF MODE HIGH BYTE REGISTER – 0XE24

Bit	R/W	Default	Description
1:0	RW	0	ROSD_STATUS_X_LEFT[9:8] Status horizontal left position for half D1, Quad and CIF mode. Unit is 1 pixel

ROSD STATUS HORIZONTAL RIGHT POSTION FOR HALF MODE LOW BYTE REGISTER – 0XE25

Bit	R/W	Default	Description
7:0	RW	0	ROSD_STATUS_X_RIGHT[7:0] Status horizontal right position for half D1, Quad and CIF mode. Unit is 1 pixel

ROSD STATUS HORIZONTAL RIGHT POSTION FOR HALF MODE HIGH BYTE REGISTER – 0XE26

Bit	R/W	Default	Description
1:0	RW	0	ROSD_STATUS_X_RIGHT[9:8] Status horizontal right position for half D1, Quad and CIF mode. Unit is 1 pixel

ROSD STATUS VERTICAL POSTION FOR FULL MODE LOW BYTE REGISTER – 0XE27

Bit	R/W	Default	Description
7:0	RW	0	ROSD_STATUS_Y_FULL[7:0] Status vertical position for D1 and half D1 mode. Unit is 1 pixel

ROSD STATUS VERTICAL POSTION FOR FULL MODE HIGH BYTE REGISTER – 0XE28

Bit	R/W	Default	Description
1:0	RW	0	ROSD_STATUS_Y_FULL[9:8] Status vertical position for D1 and half D1 mode. Unit is 1 pixel

ROSD STATUS VERTICAL TOP POSTION FOR HALF MODE LOW BYTE REGISTER – 0XE29

Bit	R/W	Default	Description
7:0	RW	0	ROSD_STATUS_Y_TOP[7:0] Status vertical top position for Quad and CIF mode. Unit is 1 pixel

ROSD STATUS VERTICAL TOP POSITION FOR HALF MODE HIGH BYTE REGISTER – 0XE2A

Bit	R/W	Default	Description
1:0	RW	0	ROSD_STATUS_Y_TOP[9:8] Status vertical top position for Quad and CIF mode. Unit is 1 pixel

ROSD STATUS VERTICAL BOTTOM POSITION FOR HALF MODE LOW BYTE REGISTER – 0XE2B

Bit	R/W	Default	Description
7:0	RW	0	ROSD_STATUS_Y_BOTTOM[7:0] Status vertical bottom position for Quad and CIF mode. Unit is 1 pixel

ROSD STATUS VERTICAL BOTTOM POSITION FOR HALF MODE HIGH BYTE REGISTER – 0XE2C

Bit	R/W	Default	Description
1:0	RW	0	ROSD_STATUS_Y_BOTTOM[9:8] Status vertical bottom position for Quad and CIF mode. Unit is 1 pixel

ROSD FONT Y COLOR 1 REGISTER – 0XE2D

Bit	R/W	Default	Description
7:0	RW	0x10	ROSD_FONT_Y1[7:0] Font color Y for index 1

ROSD FONT CB COLOR 1 REGISTER – 0XE2E

Bit	R/W	Default	Description
7:0	RW	0x80	ROSD_FONT_CB1[7:0] Font color Cb for index 1

ROSD FONT CR COLOR 1 REGISTER – 0XE2F

Bit	R/W	Default	Description
7:0	RW	0x80	ROSD_FONT_CR1[7:0] Font color Cr for index 1

ROSD FONT Y COLOR 2 REGISTER – 0XE30

Bit	R/W	Default	Description
7:0	RW	0x10	ROSD_FONT_Y2[7:0] Font color Y for index 2

ROSD FONT CB COLOR 2 REGISTER – 0XE31

Bit	R/W	Default	Description
7:0	RW	0x80	ROSD_FONT_CB2[7:0] Font color Cb for index 2

ROSD FONT CR COLOR 2 REGISTER – 0XE32

Bit	R/W	Default	Description
7:0	RW	0x80	ROSD_FONT_CR2[7:0] Font color Cr for index 2

ROSD FONT Y COLOR 3 REGISTER – 0XE33

Bit	R/W	Default	Description
7:0	RW	0x10	ROSD_FONT_Y3[7:0] Font color Y for index 3

ROSD FONT CB COLOR 3 REGISTER – 0XE34

Bit	R/W	Default	Description
7:0	RW	0x80	ROSD_FONT_CB3[7:0] Font color Cb for index 3

ROSD FONT CR COLOR 3 REGISTER – 0XE35

Bit	R/W	Default	Description
7:0	RW	0x80	ROSD_FONT_CR3[7:0] Font color Cr for index 3

ROSD BACKGROUND Y COLOR REGISTER – 0XE36

Bit	R/W	Default	Description
7:0	RW	0x10	ROSD_BGND_Y [7:0] Background color Y

ROSD BACKGROUND CB COLOR REGISTER – 0XE37

Bit	R/W	Default	Description
7:0	RW	0x80	ROSD_BGND_CB[7:0] Background color Cb

ROSD BACKGROUND CR COLOR REGISTER – 0XE38

Bit	R/W	Default	Description
7:0	RW	0x80	ROSD_BGND_CR[7:0] Background color Cr

ROSD BOUNDARY Y COLOR REGISTER – 0XE39

Bit	R/W	Default	Description
7:0	RW	0x10	ROSD_BNDRY_Y[7:0] Boundary color Y

ROSD BOUNDARY CB COLOR REGISTER – 0XE3A

Bit	R/W	Default	Description
7:0	RW	0x80	ROSD_BNDRY_CB[7:0] Boundary color Cb

ROSD BOUNDARY CR COLOR REGISTER – 0XE3B

Bit	R/W	Default	Description
7:0	RW	0x80	ROSD_BNDRY_CR[7:0] Boundary color Cr

ROSD FONT RAM ADDRESS LOW BYTE REGISTER – 0XE3C

Bit	R/W	Default	Description
7:0	RW	0	ROSD_FRAM_ADDR[7:0] Font SRAM address. When host write data to this SRAM, address is written first and then data. SRAM size is 640x16.

ROSD FONT RAM ADDRESS HIGH BYTE REGISTER – 0XE3D

Bit	R/W	Default	Description
1:0	RW	0	ROSD_FRAM_ADDR[9:8] Font SRAM address. When host write data to this SRAM, address is written first and then data. SRAM size is 640x16.

ROSD FONT RAM DATA LOW BYTE REGISTER – 0XE3E

Bit	R/W	Default	Description
7:0	RW	0	ROSD_FRAM_DATA[7:0] Font SRAM address. When host write data to this SRAM, address is written first and then data. SRAM size is 640x16.

ROSD FONT RAM DATA HIGH BYTE REGISTER – 0XE3F

Bit	R/W	Default	Description
7:0	RW	0	ROSD_FRAM_DATA[15:8] Font SRAM address. When host write data to this SRAM, address is written first and then data. SRAM size is 640x16.

ROSD DISPLAY RAM ADDRESS REGISTER – 0XE40

Bit	R/W	Default	Description
7:0	RW	0	ROSD_DRAM_ADDR[7:0] Display SRAM address. When host write data to this SRAM, address is written first and then data. SRAM size is 544x6.

ROSD DISPLAY RAM ADDRESS REGISTER – 0XE41

Bit	R/W	Default	Description
1:0	RW	0	ROSD_DRAM_ADDR[9:8] Display SRAM address. When host write data to this SRAM, address is written first and then data. SRAM size is 544x6.

ROSD DISPLAY RAM DATA REGISTER – 0XE42

Bit	R/W	Default	Description
7:0	RW	0	ROSD_DRAM_Data[5:0] Display SRAM address. When host write data to this SRAM, address is written first and then data. SRAM size is 544x6.

ROSD COLOR BAR ENABLE REGISTER – 0XE43

Bit	R/W	Default	Description
7:0	RW	0	ROSD_COLBAR_EN [7]: ROSD_COLBAR_EN8 [6]: ROSD_COLBAR_EN7 [5]: ROSD_COLBAR_EN6 [4]: ROSD_COLBAR_EN5 [3]: ROSD_COLBAR_EN4 [2]: ROSD_COLBAR_EN3 [1]: ROSD_COLBAR_EN2 [0]: ROSD_COLBAR_EN1 Recording port n (1 to 8) color bar enable or disable.

ROSD ENABLE FOR PORT 9 REGISTER – 0XE44

Bit	R/W	Default	Description
7:0	RW	0	[7]: ROSD_COLBAR_EN9 [6]: ROSD_MIX_9 [5]: ROSD_BGND_EN9 [4]: ROSD_BNDRY_EN9 [3]: ROSD_STATUS_EN9 [2]: ROSD_TITLE_EN9 [1]: ROSD_TIME_EN9 [0]: ROSD_EN9

ROSD COLBAR VERTICAL BLACK BAR POSITION REGISTER – 0XE45

Bit	R/W	Default	Description
7:0	RW	0	ROSD_COLBAR_VPOS[7:0] There is a black bar (32 lines) in color bar. This register defines start position for this bar. It is for test purpose.

ROSD FIELD SWITCHING CONTROL REGISTER – 0XE46

Bit	R/W	Default	Description
7:0	RW	0	ROSD_FSWITCH[7:0]: Field switch mode for record port 0 to 7 0: not field switch 1: field switch

PRIVACY WINDOW OVERFLOW REGISTER 1 – 0XE47

Bit	R/W	Default	Description
7:0	RW	0	Channel 7-0 Overflow bit for Window 1

PRIVACY WINDOW OVERFLOW REGISTER 2 – 0XE48

Bit	R/W	Default	Description
7:0	RW	0	Channel 15-8 Overflow bit for Window 1

Similar functions are distributed in 0xE49 – 0xE4E for Window 2 – Window 4

PRIVACY WINDOW SHADOW SET CONTROL REGISTER – 0XE4F

Bit	R/W	Default	Description
7	RW	0	ROSD_FSWITCH[8]: Field switch mode for network port 0: not field switch 1: field switch
6:3	R	0	Reserved
2	RW	0	Select Vertical This bit control the overflow bit. 1 = Select vertical

Bit	R/W	Default	Description
1:0	RW	0	Shadow set control for each live, record, SPOT privacy channels 00: Record 01: SPOT 10: Live 11: Reserved

PRIVACY WINDOW 1 HORIZONTAL START REGISTER – 0XE50 – 0XE5F

Bit	R/W	Default	Description
0	RW	0	HSTART[7:0] for each channel This values is the horizontal starting point for privacy window 1. Unit is double pixel.

PRIVACY WINDOW 1 VERTICAL START REGISTER – 0XE60 – 0XE6F

Bit	R/W	Default	Description
7	R/W	0	1 = Enable Window
6:0	RW	0	VSTART[6:0] for each channel This values is the vertical starting point for privacy window 1. Unit is quadruple line.

PRIVACY WINDOW 1 CONTROL REGISTER – 0XE70 – 0XE7F

Bit	R/W	Default	Description
7:5	R/W	0	Content operation 000: solid white color 001: solid black color 010: over exposed 011: under exposed 100: Mosaic block size is 8x8 101: Mosaic block size is 16x16 110: Mosaic block size is 32x32 111: Mosaic block size is 64x64

Bit	R/W	Default	Description
4:2	R/W	0	Horizontal size select 000: 32 001: 64 010: 128 011: 256 100: 320 101: 640 110: 960 111: 1440
1:0	R/W	0	Vertical size select 00: 32 01: 64 10: 128 11: 288

PRIVACY WINDOW 2 HORIZONTAL START REGISTER – 0XE80 – 0XE8F

Bit	R/W	Default	Description
0	RW	0	HSTART[7:0] for each channel This values is the horizontal starting point for privacy window 2. Unit is double pixel. If WIN4_CON[6] is one, this becomes user color Y register.

PRIVACY WINDOW 2 VERTICAL START REGISTER – 0XE90 – 0XE9F

Bit	R/W	Default	Description
7	R/W	0	1 = Enable Window
6:0	RW	0	VSTART[6:0] for each channel This values is the vertical starting point for privacy window 2. Unit is quadruple line.

PRIVACY WINDOW 2 CONTROL REGISTER – 0XEAO – 0XEAF

Bit	R/W	Default	Description
7:5	R/W	0	Control over exposed value 000: light, 111: is the over
4:2	R/W	0	Horizontal size select 000: 32 001: 64 010: 128 011: 256 100: 320 101: 640 110: 960 111:1440
1:0	R/W	0	Vertical size select 00: 32 01: 64 10: 128 11: 288

PRIVACY WINDOW 3 HORIZONTAL START REGISTER – 0XEBO – 0XEBF

Bit	R/W	Default	Description
0	RW	0	HSTART[7:0] for each channel This values is the horizontal starting point for privacy window 3. Unit is double pixel. If WIN4_CON[6] is one, this becomes user color Cb register.

PRIVACY WINDOW 3 VERTICAL START REGISTER – 0XEC0 – 0XECF

Bit	R/W	Default	Description
7	R/W	0	1 = Enable Window
6:0	RW	0	VSTART[6:0] for each channel This values is the vertical starting point for privacy window 3. Unit is quadruple line.

PRIVACY WINDOW 3 CONTROL REGISTER – 0XED0 – 0XEDF

Bit	R/W	Default	Description
7	R/W	0	Reserved
6:5	R/W	0	Under exposed value select 00: 1/8 of the original 01: 1/16 of the original 10: 1/32 of the original 11: 1/64 of the original
4:2	R/W	0	Horizontal size select 000: 32 001: 64 010: 128 011: 256 100: 320 101: 640 110: 960 111:1440
1:0	R/W	0	Vertical size select 00: 32 01: 64 10: 128 11: 288

PRIVACY WINDOW 4 HORIZONTAL START REGISTER – 0XDD0 – 0XDDF

Bit	R/W	Default	Description
0	RW	0	HSTART[7:0] for each channel This values is the horizontal starting point for privacy window 4. Unit is double pixel. If WIN4_CON[6] is one, this becomes user color Cr register.

PRIVACY WINDOW 4 VERTICAL START REGISTER – 0XDE0 – 0XDEF

Bit	R/W	Default	Description
7	R/W	0	1 = Enable Window
6:0	RW	0	VSTART[6:0] for each channel This values is the vertical starting point for privacy window 4. Unit is quadruple line.

PRIVACY WINDOW 4 CONTROL REGISTER – 0XDFO – 0XDFF

Bit	R/W	Default	Description
7	R/W	0	Horizontal Resolution Select 1 = use HSTART[7;0] as HSTART[8:1] 0 = use overflow H bit as HSTART[8]
6	R/W	0	User color update enable 1 = Enable user to update desired color into HPOS2, HPOS3, HPOS4 as Y. Cb, Cr 0 = Normal operation
5	R/W	0	User color substitute enable 1 = Enable the user color switch 0 = Normal operation
4:2	R/W	0	Horizontal size select 000: 32 001: 64 010: 128 011: 256 100: 320 101: 640 110: 960 111:1440
1:0	R/W	0	Vertical size select 00: 32 01: 64 10: 128 11: 288

SPOT Controller Unit

Introduction

TW2880 has a very powerful SPOT display controller which can support four independent TV output (NTSC or PAL). By integrating the TV encoder and the DAC, this controller provide glues less interface to the traditional TV to show the recording content which include the current field being recorded, background color, camera number, border divider and OSD for the date and time being recorded. With properly software registers setup the SPOT display controller can show all sixteen scaled down D1 windows on one display or shows four D1 recording video stream in a serial rotating fashion. The rotating rate, sources and sizes are programmable through registers.

Features

- Supports NTSC / PAL standard TV monitor with integrated 10 bit DAC
- Four SPOT controllers to display four D1 or Quad channel simultaneously
- Down scaling support up to 1440x960 resolution
- 27 MHZ output frequency
- Programmable sync timing
- Programmable Channel rotation
- Programmable Back ground color
- Programmable Border control
- Programmable Camera on-off display and location
- Programmable OSD display font and location for the time, date
- Programmable to display REC ports or Network Port to any SPOT

SPOT Controller Architecture

For the SPOT controller to display the REC video channels on the TV screen, the memory location need to be programmed for the controller to fetch data at the right area, Firmware needs to set the each spot starting address, size, down scale factors, background color, border width and all TV parameters control registers for the CRT monitor to display properly.

MEMORY ACCESS CONTROL

In the memory mapping, the SPOT controller needs to access the location where the recorded data were written by the encoder interface module. By programming the SPOT HSTART, SPOT VSTART registers, the SPOT controller will display the channel video as the record path.

FRAME DATA SYNCHONIZATION

To prevent the video tearing, the SPOT controller takes use the frame rate synchronization circuit which will guarantee two frames difference between active display frame and active storing frame. If the frame rate of the SPOT controller is higher than the incoming video pipe, frame repeating process is employed to make sure the two frame boundary is maintained.

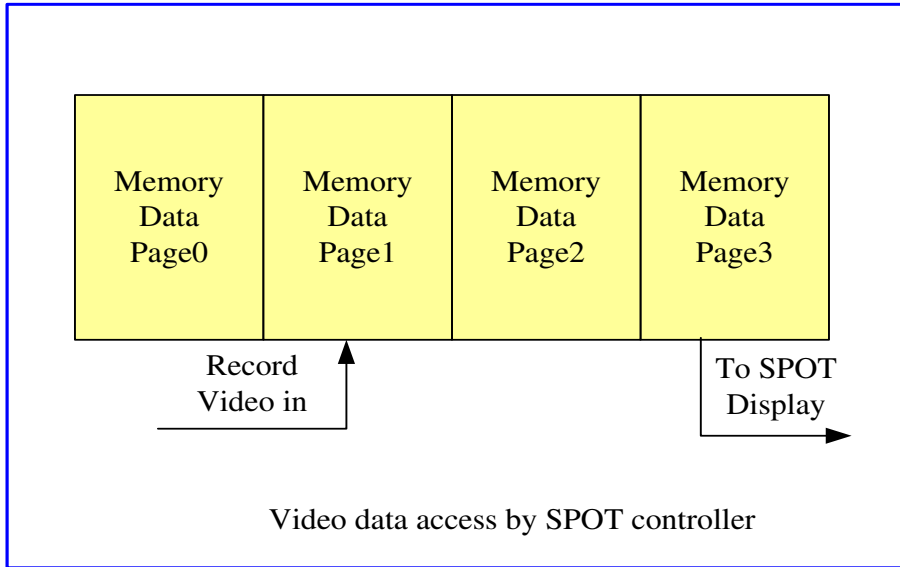

SPOT CONTROLLER BLOCK DIAGRAM

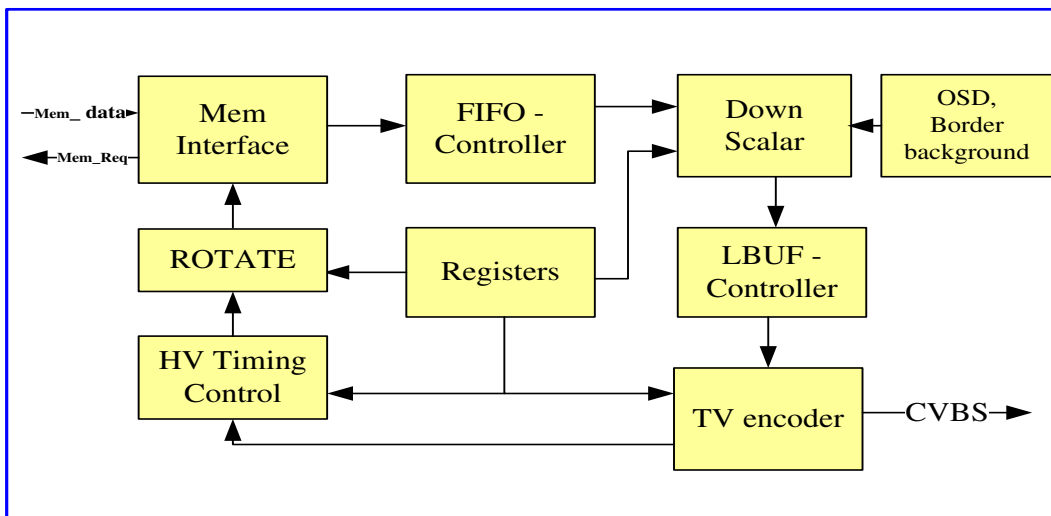

SPOT controller Block Diagram

MEMORY INTERFACE

Base on the information of Horizontal and vertical timing, and under registers control, Memory Interface is a module uses to generate request to the DRAM controller and ask for the DRAM access to get the display data from the DRAM and send it the FIFO.

ROTATION CONTROL

Base on the information of Horizontal and vertical timing, and under registers control, Rotation control will jump to other location to fetch the new data to display on the screen with the programmed update rate for each video channel.

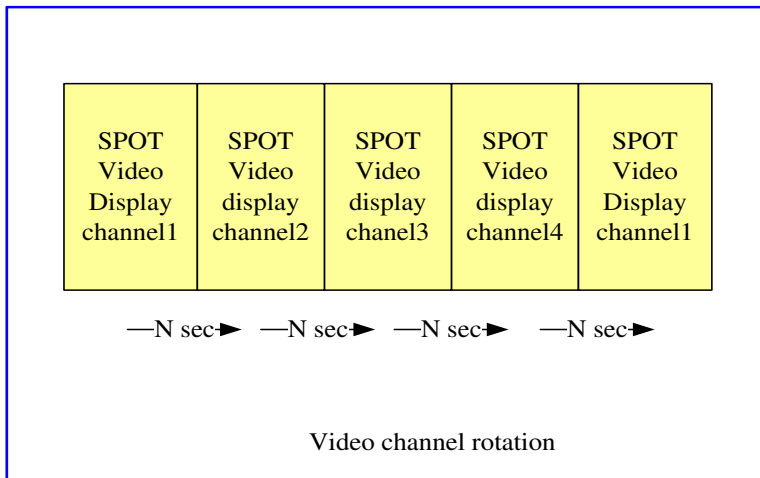

FIFO INTERFACE

Due to the memory clock and video clock running in different frequency, SPOT controller includes a 128 deep by 64 bit wide FIFO to synchronize the data for cross clock domain operation.

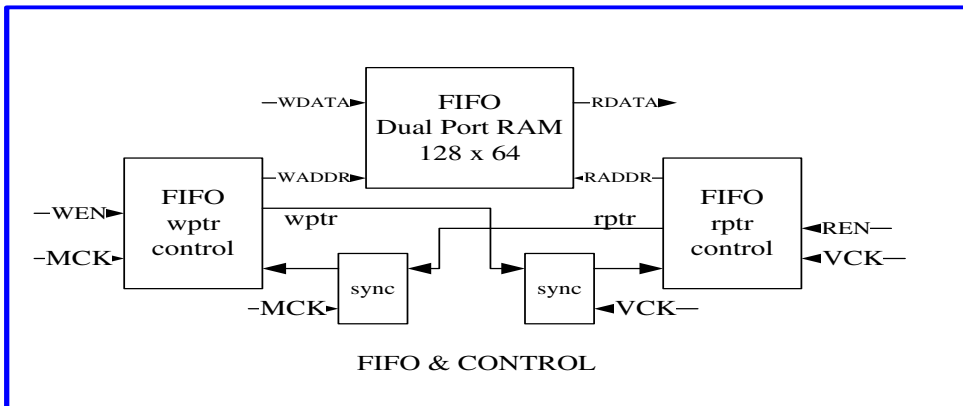

HV TIMING CONTROL

Base on the setting of horizontal and vertical registers and the inputs information of the TV Encoder, The HV timing control module generates all pixels, lines, and blanking signals and feed them to the Memory interface module to request data from DRAM.

Depends on the Odd or Even field indicator output from the TV, The Dram Interface module will generate the memory address in that field and fetches data from the line memory, and send to the Down Scale controller and processes the image according the scale factor and send it to the Line Buffers.

DOWN SCALAR

Down scalar is a module uses to scale down more channels on the display to fit the TV standard timing. So on the second monitor, we can pack as many channels as seen on the LCD and display them on a regular TV.

By using the linear interpolation technique, with independent setting of horizontal and vertical scale factors and others registers. We can scale the number of channels, the size and the location of the channels to the display's native resolution.

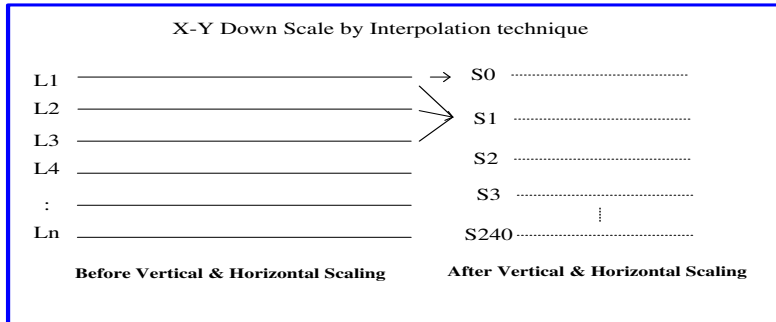

LBUF CONTROL

Due to the clock rate difference of the Down Scalar and the TV Encoder, there are two line buffers size of 720x16 to accommodate the timing of the TV Encoder.

OSD, BACKGROUND AND BORDER CONTROL

SPOT controller has an OSD controller for recording path displays channel information for each channel. The OSD controller is a font based design. All font tables are stored in local SRAM. Channel information includes 32 characters date/time, 16 characters title and 16 characters status. There are totally 64 fonts saved in SRAM. Font width can be selected from 6, 8, 12 or 16. Font height can be selected from 8, 10, 16 or 20. Channel information is also saved in local SRAM. Besides channel information layer, there are background layer and channel boundary layer. Following are the features supported in the SPOT display operation.

- 4 OSD engines for 4 SPOT ports
- 64 fonts table saved in SRAM
- Channel information table saved in SRAM
- Three lines channel information
- 32 characters date/time
- 8 characters channel title for each channel
- 1 picture for each channel
- 32 characters status for each channel
- font size can be changed
- Channel Boundary
- Background
- Color Bar

For detailed operation, please refer to the "OSD for Recording Path" section beginning on page 452.

TV ENCODER

TV Encoder is the module converts all component data from scalar into a standard analog baseband television signal (CVBS) which is compatible with worldwide standards. Follow is the PAL timing.

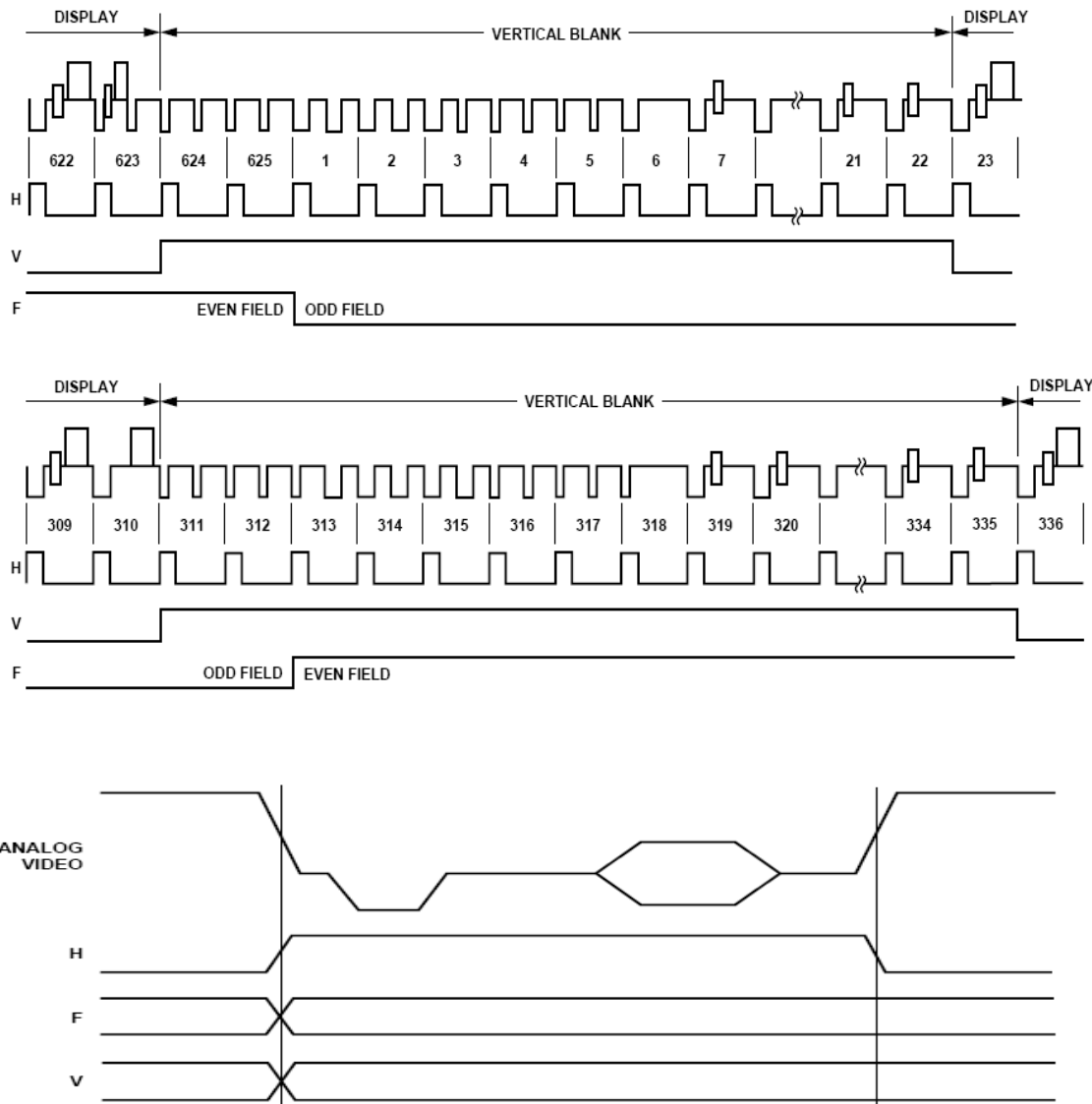

THEORY OF OPERATION

When the SPOT controller is enabling, the controller can access the whole memory map and display the content with the start address set by the HSTART and the VSTART registers. Of course, if the setting is out of bound, the display will show something on the screen with no meaning at all. So for the controller to operate properly, some registers need to be set.

While the controller has quit a few registers, there are a few registers need to be adjust, others just are default values. Here are the registers needed to change if the resolutions, scaling, and different memory location wanted to be displayed.

In the calculation, the vertical period time is based on the TV standard vertical period.

In NTSC, this is 16.667 ms in each field, in the 1440x960 mode. Base on the 960 line per field in interlace mode, there are 480 lines in either odd or even field and scaled down to 240 lines plus some blank lines for NTSC standard.

In NTSC mode:

Each field total pixel = $525 * (1440 + \text{undisplay_pixel})$

Each field total time = 16.678 ms

Total pixels per field (calculated from field period and 108 MHz) = $16.678 \text{ ms} / (1/108 \text{ MHz}) = 1,801,224$ pixels

Undisplay_pixel = $(1801224 - 525 * 1440) / 525 = 1045224 / 525 = 1991$

SP_HTT = $1991 + 1440 = 3431 = \text{'hD67}$

SP_HDE = 1439 = 'h59F

SP_VTT = 523 = 'h20B

SP_VDE = 479 = 'h1DF

SP_SRC_WID = 1440 = 'h5A0

SP_SRC_HI = 480 = 'h1E0

SP_DST_WID = 720 = 'h2D0

SP_DST_HI = 240 = 'hF0

If SPOT is set to display in D1 or quad mode.

SP_HTT = 6863 = 'h1ACF

SP_HDE = 719 = 'h2CF

SP_VTT = 261 = 'h105

SP_VDE = 239 = 'hEF

SP_SRC_WID = 720 = 'h2D0

SP_SRC_HI = 240 = 'hF0

SP_DST_WID = 720 = 'h2D0

SP_DST_HI = 240 = 'hF0

In Pal mode:

The SPOT is set to D1 or quad mode

SP_HTT = 6863 = 'h1ACF

SP_HDE = 719 = 'h2CF

SP_VTT = 311 = 'h137

SP_VDE = 287 = 'h11F

SP_SRC_WID = 720 = 'h2D0

SP_SRC_HI = 240 = 'hF0

SP_DST_WID = 720 = 'h2D0

SP_DST_HI = 240 = 'hF0

SP_TV_CTRL(reg 'hF17) = 'h41

SP_TV_CTRL(reg 'hF18) = 'h05

Registers Table

Address	R/W	Default	Description
0xF00	R/W	0x00	SP1_HTT[7:0], SPOT1 Horizontal Total Register
0xF01	R/W	0x00	SP1_HTT[12:8], SPOT1 Horizontal Total Register
0xF02	R/W	0x00	SP1_HDE[7:0], SPOT1 Horizontal Display Enable Register
0xF03	R/W	0x00	SP1_HDE[11:8], SPOT1 Horizontal Display Enable Register
0xF04	R/W	0x00	SP1_VDE[7:0], SPOT1 Vertical Display Enable Register
0xF05	R/W	0x00	[7:4] BND_CH_EN[3:0] SPOT Border Channel Enable [2:0] SP1_VDE[10:8], SPOT1 Vertical Display Enable Register
0xF06	R/W	0x00	SP1_HSYNC[7:0], SPOT1 Horizontal Sync register
0xF07	R/W	0x00	SP_BND_WIDTH_V[3:0], Border Width in Vertical direction in Field Switching Mode [7:4] SP_BND_WIDTH_V[3:0] [3:2] SP1_FRSC [1] SPOT Reset FRSC bank sel when no video detection active [0] SP1_HSYNC[8]
0xF08	R/W	0x00	SP1_VSYNC[7:0], SPOT1 Vertical Sync Register
0xF09	R/W	0x00	SP1_VTT[7:0], SPOT1 Vertical Total Register low byte, HI Byte is in FOA registers
0xF0A	R/W	0x06	SP1_VTT[10:8], SPOT1 VTT Total Register [7] SP1_Half_D1 Select [6:3] RESERVED [2:0] SP1_VTT[10:8]
0xF0B	R/W	0x00	SP Frame Rate Control and Vblank Select [7:6] Vblank Select from one of the four SPOT for FRSC [5] SP1 Colorbar Enable [4] RESERVED [3:2] SP1_FLD select 11: use bank0 from the FRSC as the field 10: use bank0 from the FRSC inverse as the filed 0x: use HVCNT generated field [1:0] reserved
0xF0C	R/W	0x00	SP_ROT_INT_EN [7] SP4 Rot Int status [6] SP3 Rot Int status [5] SP2 Rot Int status [4] SP1 Rot Int status [3] SP4 Rot Int Enable [2] SP3 Rot Int Enable [1] SP2 Rot Int Enable [0] SP1 Rot Int Enable
0xF0D	R/W	0x00	SP1_DNS Upper Bits, lower byte in reg F13, F14, F15, F16 [7:6] SP1 Down Scaler Destination Width upper bit [9:8] [5:3] SP1 Down Scaler Source Height upper bit [10:8] [2:0] SP1 Down Scaler Source Width upper bit [10:8]
0xF0E	R/W	0x00	[7] SP1 REC or Network Port input enable [6:4] SP1 Internal Color Bar test Select [3:1] SP1 Line Buffer First line Control [0] SP1 Down scaler Destination Height upper bit [8]

Address	R/W	Default	Description
0xF0F	R/W	0x00	SPOT1 Enable Register [7] SP1_FLD_MODE [6] SP1_2 ND _MEM [5] SP1_FRMCNT_EN, SPOT1 Frame Count Enable [4] SP1_ENA, SPOT1 Enable [3:2] SP1_ROT_EN, SPOT1 Rotate Enable [1] SP1_VS_POL, SPOT1 Vsync Polarity Select [0] SP1_HS_POL, SPOT1 Hsync Polarity Select
0xF10	R/W	0x00	SP1_HSTART[7:0], SPOT1 Horizontal Start Address Register
0xF11	R/W	0x00	SP1_VSTART[7:0], SPOT1 Vertical Start Address Register
0xF12	R/W	0x00	[7] SP1 Mode Enable [5:4] SP1_HSTART[9:8], SPOT1 Horizontal Start Address Register [3:0] SP1_VSTART[11:8], SPOT1 Vertical Start Address Register
0xF13	R/W	0x00	SP1_SRC_Width[7:0], SPOT1 DNS Source width Register, upper 3 bit locates in 0xF0D[2:0]
0xF14	R/W	0x00	SP1_SRC_Height[7:0], SPOT1 DNS Source height Register, upper 3 bit locates in 0xF0D[5:3]
0xF15	R/W	0x00	SP1_DST_Width[7:0], SPOT1 DNS Destination width Register, upper 3 bit locates in 0xF0D[7:6]
0xF16	R/W	0x00	SP1_DST_Height[7:0], SPOT1 DNS Destination height Register, upper 1 bit locates in 0xF0E[0]
0xF17	R/W	0x00	SP1_TVE_STD[7:0], SPOT1 TV Standard Register
0xF18	R/W	0x00	SP1_TVE_POL[7:0], SPOT1 TV Sync Polarity Register
0xF19	R/W	0x00	SP1_TVE_FDET[6:0], SPOT1 TV Field Control Register
0xF1A	R/W	0x00	SP1_TVE_HSENC[7:0], SPOT1 TV Encoder Active Pixel delay
0xF1B	R/W	0x00	SP1_TVE_HSENC[9:8], [7:2] SPOT1 Rotate Time Offset [1:0] SPOT1 TV Encoder Active Pixel delay
0xF1C	R/W	0x00	[7:6] SP1_CVBS_SRC_SEL [5:0] SP1_TVE_VSENC[5:0], SPOT1 TV Encoder Active Line delay
0xF1D	R/W	0x00	SP1_TVE_LINE_OS[4:0], SPOT1 TV Encoder Active Line offset
0xF1E	R/W	0x00	[7:6] SP1_FLD_SW_MODE [5:0] SP1_TVE_PIXEL_OS[5:0], SPOT1 TV Encoder Active Pixel Offset
0xF1F	R/W	0x00	SP1_TVE_FLD_OS[1:0], SPOT1 TV Encoder Active Field offset
0xF20	R/W	0x00	SP1_TVE_FSC_FREE[7], SPOT1 TV Encoder Subcarrier run free [6:0] RESERVED
0xF21	R/W	0x00	[7:0] Vertical Start Address offset [7:0] in 256 or 512 Mb mem config.
0xF22	R/W	0x00	SPOT_BACKGND_R[7:0], SPOT Background Red Color
0xF23	R/W	0x00	SPOT_BACKGND_G[7:0], SPOT Background Green Color
0xF24	R/W	0x00	SPOT_BACKGND_B[7:0], SPOT Background Blue Color
0xF25	R/W	0x00	[7] SPOT Switch Enable [6] SPOT Internal Color Bar Enable [4] SP1_BRDR_EN, SPOT1 Border Enable [3:0] SPOT Border Width
0xF26	R/W	0x00	SPOT_BORDER COLOR R[7:0], SPOT BORDER Red Color
0xF27	R/W	0x00	SPOT_BORDER COLOR G[7:0], SPOT BORDER Green Color
0xF28	R/W	0x00	SPOT_BORDER COLOR B[7:0], SPOT BORDER Blue Color
0xF29	R/W	0x00	SPOT_ROT_FREQ[7:0], SPOT Channel Rotate Frequency
0xF2A	R/W	0x00	SP2_OSD_DRAM_ADDR[7:0]
0xF2B	R/W	0x00	SP2_OSD_DRAM_DATA[5:0]
0xF2C	R/W	0x00	SP3_OSD_DRAM_ADDR[7:0]
0xF2D	R/W	0x00	SP3_OSD_DRAM_DATA[5:0]
0xF2E	R/W	0x00	SP4_OSD_DRAM_ADDR[7:0]

Address	R/W	Default	Description
0xF2F	R/W	0x00	SP4_OSD_DRAM_DATA[5:0]
0xF30	R/W	0x00	SPOT_BORDER_ENABLE [7] SPOT4_BORDER_EN [6] SPOT3_BORDER_EN [5] SPOT2_BORDER_EN [4] SP1_OSD_TITLE_EN [3] SP1_OSD_TIME_EN [2] SP1_OSD_CHPIC_EN [1] SP1_OSD_CHNUM_EN [0] SP1_OSD_EN
0xF31	R/W	0x00	SPOT1 OSD Control Register [5] SP1_OSD_CHPIC_BLINK [4] SP1_OSD_CHPIC_TRANS [3] SP1_OSD_TITLE_MIX [2] SP1_OSD_TIME_MIX [1] SP1_OSD_CHPIC_MIX [0] SP1_OSD_CHNUM_MIX
0xF32	R/W	0x00	[7:6] SP1_OSD_CHPIC_POS [5:4] SP1_OSD_CHNUM_POS [3:2] SP1_OSD_FONT_VSIZE [1:0] SP1_OSD_FONT_HSIZE
0xF33	R/W	0x00	SPOT_OSD_CHNUM_HPOS[7:0]
0xF34	R/W	0x00	SPOT_OSD_CHNUM_HPOS[10:8]
0xF35	R/W	0x00	SPOT_OSD_CHNUM_VPOS[7:0]
0xF36	R/W	0x00	[7:3] SP1_FRC_CTL [2:0] SPOT_OSD_CHNUM_VPOS[10:8]
0xF37	R/W	0x80	SPOT_OSD_CHPIC_HPOS[7:0]
0xF38	R/W	0x80	[7:3] SP2_FRC_CTL SPOT_OSD_CHPIC_HPOS[10:8]
0xF39	R/W	0x10	SPOT_OSD_CHPIC_VPOS[7:0]
0xF3A	R/W	0x00	[7:3] SP3_FRC_CTL SPOT_OSD_CHPIC_VPOS[10:8]
0xF3B	R/W	0x00	SPOT_OSD_TIME_HPOS[7:0]
0xF3C	R/W	0x00	[7:3] SP4_FRC_CTL SPOT_OSD_TIME_HPOS[10:8]
0xF3D	R/W	0x00	SPOT_OSD_TIME_VPOS[7:0]
0xF3E	R/W	0x00	SPOT_OSD_TIME_VPOS[10:8]
0xF3F	R/W	0x00	SPOT_OSD_TITLE_HPOS[7:0]
0xF40	R/W	0x00	SPOT_OSD_TITLE_HPOS[10:8]
0xF41	R/W	0x00	SPOT_OSD_TITLE_VPOS[7:0]
0xF42	R/W	0x00	SPOT_OSD_TITLE_VPOS[10:8]
0xF43	R/W	0x00	SPOT_OSD_FONT_PR1[7:0]
0xF44	R/W	0x00	SPOT_OSD_FONT_Y1[7:0]
0xF45	R/W	0x00	SPOT_OSD_FONT_PB1[7:0]
0xF46	R/W	0x00	SPOT_OSD_FONT_PR2[7:0]
0xF47	R/W	0x00	SPOT_OSD_FONT_Y2[7:0]
0xF48	R/W	0x00	SPOT_OSD_FONT_PB2[7:0]
0xF49	R/W	0x00	SPOT_OSD_FONT_PR3[7:0]
0xF4A	R/W	0x00	SPOT_OSD_FONT_Y3[7:0]
0xF4B	R/W	0x00	SPOT_OSD_FONT_PB3[7:0]
0xF4C	R/W	0x00	SPOT_OSD_PIC_PRO[7:0]
0xF4D	R/W	0x00	SPOT_OSD_PIC_Y0[7:0]

Address	R/W	Default	Description
0xF4E	R/W	0x00	SPOT_OSD_PIC_PB0[7:0]
0xF4F	R/W	0x00	SPOT_OSD_PIC_PR1[7:0]
0xF50	R/W	0x00	SPOT_OSD_PIC_Y1[7:0]
0xF51	R/W	0x00	SPOT_OSD_PIC_PB1[7:0]
0xF52	R/W	0x00	SPOT_OSD_PIC_PR2[7:0]
0xF53	R/W	0x00	SPOT_OSD_PIC_Y2[7:0]
0xF54	R/W	0x00	SPOT_OSD_PIC_PB2[7:0]
0xF55	R/W	0x00	SPOT_OSD_PIC_PR3[7:0]
0xF56	R/W	0x00	SPOT_OSD_PIC_Y3[7:0]
0xF57	R/W	0x00	SPOT_OSD_PIC_PB3[7:0]
0xF58	R/W	0x00	SP1_OSD_FRAM_ADDR[7:0]
0xF59	R/W	0x00	SP1_OSD_FRAM_ADDR[10:8]
0xF5A	R/W	0x00	SP1_OSD_FRAM_DATA[7:0]
0xF5B	R/W	0x00	SP1_OSD_FRAM_DATA[15:8]
0xF5C	R/W	0x00	SP1_OSD_DRAM_ADDR[7:0]
0xF5D	R/W	0x00	SP1_OSD_DRAM_DATA[5:0]
0xF5E	R/W	0x00	SPOT_DISP_PITCH[7:0]
0xF5F	R/W	0x00	SPOT_ADJUST_ENA[7:0]
0xF60	R/W	0x00	SP2_HTT[7:0], SPOT2 Horizontal Total Register
0xF61	R/W	0x00	SP2_HTT[12:8], SPOT2 Horizontal Total Register
0xF62	R/W	0x00	SP2_HDE[7:0], SPOT2 Horizontal Display Enable Register
0xF63	R/W	0x00	SP2_HDE[11:8], SPOT2 Horizontal Display Enable Register
0xF64	R/W	0x00	SP2_VDE[7:0], SPOT2 Vertical Display Enable Register
0xF65	R/W	0x00	[7:4] BND_CH_EN SPOT Border Channel Enable [3] RESERVED [2:0] SP2_VDE[10:8], SPOT2 Vertical Display Enable Register
0xF66	R/W	0x00	SP2_HSYNC[7:0], SPOT2 Horizontal Position Sync Register
0xF67	R/W	0x00	SP_BND_WIDTH_SEL[3:0], Border Width in Vertical direction in Field Switching Mode [7:4] SP_BND_WIDTH_V[3:0] [3:2] SP2_FRSC [1] SP2_PHB[8] [0] SP2_PHSYNC[8]
0xF68	R/W	0x00	SP2_VSYNC[7:0], SPOT2 Vertical Position Sync Register
0xF69	R/W	0x00	SP2_VTT[7:0] SPOT2 Vertical Total Register
0xF6A	R/W	0x00	SP2_VTT[10:8] SPOT2 Vertical Total Upper Bits Register [7] SP2_Half_D1 Select [6] RESERVED [5:4] SEL656P Select 1 of 4 SPOT output to send to Network port [3] RESERVED [2:0] SP2_VTT[10:8]
0xF6B	R/W	0x00	[7:6] RESERVED [5] SP2_COLORBAR, SPOT2 Color Bar Enable Register [4] SP2_BG_SW, SPOT2 Switch Background Enable Register [3:2] SP2_FLD select 11: use bank0 from the FRSC as the field 10: use bank0 from the FRSC inverse as the filed 0x: use HVCNT generated field [1:0] reserved
0xF6C	R/W	0x00	[7:0] RESERVED

Address	R/W	Default	Description
0xF6D	R/W	0x00	SP2_DNS SPOT2 DOWN SCALE Upper Bits Register [7:6] SP2 Destination Width upper bit [9:8] [5:3] SP2 Source Height upper bit [10:8] [2:0] SP2 Source Width upper bit [10:8]
0xF6E	R/W	0x00	[7] SP2 Network Port input enable [6:5] SP2 Internal Color Bar test Select [3:1] SP2 Line Buffer First line Control [0] SP2 Destination Height upper bit [8]
0xF6D	R/W	0x00	SP2_HBDEL[7:0], SPOT2 Horizontal Blank Delay Register
0xF6E	R/W	0x00	[7] SP2_BW_CTRL, [6:4] SP2_CBAR, [0] SP2_DHB[8]
0xF6F	R/W	0x00	SPOT2 Enable Register [7] SP2_FLD_MODE [6] SP2_2 ND _MEM [5] SP2_FRMCNT_EN, SPOT2 Frame Count Enable [4] SP2_ENA, SPOT2 Enable [3:2] SP2_ROT_EN, SPOT2 Rotate Enable [1] SP2_VS_POL, SPOT2 Vsync Polarity Select [0] SP2_HS_POL, SPOT2 Hsync Polarity Select
0xF70	R/W	0x00	SP2_HSTART [7:0], SPOT2 Horizontal Start Address Register
0xF71	R/W	0x00	SP2_VSTART [7:0], SPOT2 Vertical Start Address Register
0xF72	R/W	0x00	[7] SP2 Quad Mode Enable [5:4] SP2_HSTART [9:8], SPOT2 Horizontal Start Address Register [3:0] SP2_VSTART [11:8], SPOT2 Vertical Start Address Register
0xF73	R/W	0x00	SP2_SRC_WID[7:0], SPOT2 Source width Register
0xF74	R/W	0x00	SP2_SRC_HI[7:0], SPOT2 Source height Register
0xF75	R/W	0x00	SP2_DST_WID[7:0], SPOT2 Destination width Register
0xF76	R/W	0x00	SP2_DST_HI[7:0], SPOT2 Destination height Register
0xF77	R/W	0x00	SPOT2 TV Encoder Standard Register [7:6] SP2_TVE_FSC_SEL, SPOT2 TV Encoder Fsc Select [5] SP2_TVE_SAT_LMT, SPOT2 TV Saturation Limit [0] SP2_TVE_STD, SPOT2 TV Standard Select
0xF78	R/W	0x00	SPOT2 TV Encoder Standard Register [7] SP2_TVE_VSPOL, SPOT2 TV Encoder Vertical Sync Polarity [6] SP2_TVE_HSPOL, SPOT2 TV Encoder Horiz Sync Polarity [5] SP2_TVE_VSDDET, SPOT2 TV Encoder Vsync detect [4] SP2_TVE_PED, SPOT2 TV Encoder Pedestal Enable [3] SP2_TVE_PDRST, SPOT2 TV Encoder Pedestal Reset [2] SP2_TVE_PHALT, SPOT2 TV Encoder Phase Alternated [1] SP2_TVE_F_INV, SPOT2 TV Encoder Field Inverted [0] SP2_TVE_INTL, SPOT2 TV Encoder Interlace Select
0xF79	R/W	0x00	SPOT2 TV Encoder Offset Register [5:4] SP2_TVE_PIX_OS, SPOT2 TV Encoder Pixel Offset [3:2] SP2_TVE_FLD_OS, SPOT2 TV Encoder field Offset [1] SP2_TVE_FLD_POL, SPOT2 TV Encoder Field Polarity [0] SP2_TVE_FLDDDET, SPOT2 Encoder Field Detect
0xF7A	R/W	0x00	SP2_TVE_HSENC[7:0], SPOT2 TV Encoder Active Pixel delay
0xF7B	R/W	0x00	SP2_TVE_HSENC[9:8], [7:2] SPOT2 Rotate Time Offset [1:0] SPOT2 TV Encoder Active Pixel delay
0xF7C	R/W	0x40	[7:6] SP2_CVBS_SRC_SEL [5:0] SP2_TVE_VSENC[5:0], SPOT2 TV Encoder Active Line delay
0xF7D	R/W	0x00	SP2_TVE_LINE_OS[4:0], SPOT2 TV Encoder Active Line offset

Address	R/W	Default	Description
0xF7E	R/W	0x00	[7:6] SP2_FLD_SW_MODE [5:0] SP2_TVE_PIXEL_OS[5:0], SPOT2 TV Encoder Active Pixel offset
0xF7F	R/W	0x00	SP2_TVE_FLD_OS[1:0], SPOT2 TV Encoder Active Field offset
0xF80	R/W	0x00	SP2_TVE_FSC_FREE[7], SPOT2 TV Encoder Subcarrier run free [6:0] RESERVED
0xF81	R/W	0x00	SPOT2 OSD Enable Register [4] SP2_OSD_TITLE_EN [3] SP2_OSD_TIME_EN [2] SP2_OSD_CHPIC_EN [1] SP2_OSD_CHNUM_EN [0] SP2_OSD_OSD_EN
0xF82	R/W	0x00	SPOT2 OSD Control Register [5] SP2_OSD_CHPIC_BLINK [4] SP2_OSD_CHPIC_TRANS [3] SP2_OSD_TITLE_MIX [2] SP2_OSD_TIME_MIX [1] SP2_OSD_CHPIC_MIX [0] SP2_OSD_CHNUM_MIX
0xF83	R/W	0x00	[7:6] SP2_OSD_CHPIC_POS [5:4] SP2_OSD_CHNUM_POS [3:2] SP2_OSD_FONT_VSIZE [1:0] SP2_OSD_FONT_HSIZE
0xF84	R/W	0x00	SP2_OSD_TIME_HPOS[7:0]
0xF85	R/W	0x00	SP2_OSD_TIME_HPOS[10:8]
0xF86	R/W	0x00	SP2_OSD_TIME_VPOS[7:0]
0xF87	R/W	0x00	SP2_OSD_TIME_VPOS[10:8]
0xF88	R/W	0x00	SP2_OSD_TITLE_HPOS[7:0]
0xF89	R/W	0x00	[7:3] Vertical Start Address Offset [12:8] in 256 or 512 Mb mem config SP2_OSD_TITLE_HPOS[10:8]
0xF8A	R/W	0x00	SP2_OSD_TITLE_VPOS[7:0]
0xF8B	R/W	0x00	SP2_OSD_TITLE_VPOS[10:8]
0xF8C	R/W	0x00	SP2_OSD_FRAME_ADDR[7:0]
0xF8D	R/W	0x00	SP2_OSD_FRAME_ADDR[10:8]
0xF8E	R/W	0x00	SP2_OSD_FRAME_DATA[7:0]
0xF8F	R/W	0x00	SP2_OSD_FRAME_DATA [15:8]
0xF90	R/W	0x00	SP3_HTT[7:0], SPOT3 Horizontal Total Register
0xF91	R/W	0x00	SP3_HTT[12:8], SPOT3 Horizontal Total Register
0xF92	R/W	0x00	SP3_HDE[7:0], SPOT3 Horizontal Display Enable Register
0xF93	R/W	0x00	SP3_HDE[11:8], SPOT3 Horizontal Display Enable Register
0xF94	R/W	0x00	SP3_VDE[7:0], SPOT3 Vertical Display Enable Register
0xF95	R/W	0x00	[7:4] BND_CH_EN [11:8] SPOT Border Channel Enable [3] RESERVED [2:0] SP3_VDE[10:8], SPOT3 Vertical Display Enable Register
0xF96	R/W	0x00	SP3_HSYNC[7:0], SPOT3 Horizontal Position Sync Register
0xF97	R/W	0x00	[7:4] RESERVED [3:2] SP3_FRSC [1] SP3_HBLNK[8], SPOT3 Horizontal Blank Position Register [0] SP3_HSYNC[8], SPOT3 Horizontal Sync Position Register
0xF98	R/W	0x00	SP3_VSYNC[7:0], SPOT3 Vertical Position Sync Register
0xF99	R/W	0x00	SP3_VTT[7:0], SPOT3 VTT Register
0xF9A	R/W	0x00	SP3_VTT[10:8], SPOT3 VTT Register [7] SP3_Half_D1 Select [6:3] RESERVED [2:0] SP3_VTT[10:8]

Address	R/W	Default	Description
0xF9B	R/W	0x00	[7:6] RESERVED [5] SP3_COLORBAR, SPOT3 Color Bar Enable Register [4] SP3_BG_SW, SPOT3 Switch Background Enable Register [3:2] SP3_FLD select 11: use bank0 from the FRSC as the field 10: use bank0 from the FRSC inverse as the filed 0x: use HVCNT generated field [1] SP2_PD_EN [0] SP1_PD_EN
0xF9C	R/W	0x00	SP_USE_BY_REC_NETWORK_PORT [7:4] Select REC ports 9-0 or network to replace SP2 as display port [3:0] Select REC ports 9-0 or network to replace SP1 as display port
0xF9D	R/W	0x00	SP3_DNS Down Scale register Upper Bits [7:6] SP3 Destination Width upper bit [9:8] [5:3] SP3 Source Height upper bit [10:8] [2:0] SP3 Source Width upper bit [10:8]
0xF9E	R/W	0x00	[7] SP3 Network Port input enable [6:5] SP3 Internal Color Bar test Select [3:1] SP3 Line Buffer First line Control [0] SP3 Destination Height upper bit [8]
0xF9F	R/W	0x00	SPOT3 Enable Register [7] SP3_FLD_MODE [6] SP3_2 ND _MEM [5] SP3_FRMCNT_EN, SPOT3 Frame Count Enable [4] SP3_ENA, SPOT3 Enable [3:2] SP3_ROT_EN, SPOT3 Rotate Enable [1] SP3_VS_POL, SPOT3 Vsync Polarity Select [0] SP3_HS_POL, SPOT3 Hsync Polarity Select
0xFA0	R/W	0x00	SP3_HSTART [7:0], SPOT3 Horizontal Start Address Register
0xFA1	R/W	0x00	SP3_VSTART [7:0], SPOT3 Vertical Start Address Register
0xFA2	R/W	0x00	[7] SP3 Quad Mode Enable [5:4] SP3_HSTART [9:8], SPOT3 Horizontal Start Address Register [3:0] SP3_VSTART [11:8], SPOT3 Vertical Start Address Register
0xFA3	R/W	0x00	SP3_SRC_WID[7:0], SPOT3 Source Width Register
0xFA4	R/W	0x00	SP3_SRC_HI[7:0], SPOT3 Source Height Register
0xFA5	R/W	0x00	SP3_DST_WID[7:0], SPOT3 Destination Width Register
0xFA6	R/W	0x00	SP3_DST_HI[7:0], SPOT3 Destination Height Register
0xFA7	R/W	0x00	SPOT3 TV Encoder Standard Register [7:6] SP3_TVE_FSC_SEL, SPOT3 TV Encoder Fsc Select [5] SP3_TVE_SAT_LMT, SPOT3 TV Saturation Limit [0] SP3_TVE_STD, SPOT3 TV Standard Select
0xFA8	R/W	0x00	SPOT3 TV Encoder Standard Register [7] SP3_TVE_VSPOL, SPOT3 TV Encoder Vertical Sync Polarity [6] SP3_TVE_HSPOL, SPOT3 TV Encoder Horiz Sync Polarity [5] SP3_TVE_VSDet, SPOT3 TV Encoder Vsync detect [4] SP3_TVE_PED, SPOT3 TV Encoder Pedestal Enable [3] SP3_TVE_PDRST, SPOT3 TV Encoder Pedestal Reset [2] SP3_TVE_PHALT, SPOT3 TV Encoder Phase Alternated [1] SP3_TVE_F_INV, SPOT3 TV Encoder Field Inverted [0] SP3_TVE_INTL, SPOT3 TV Encoder Interlace Select
0xFA9	R/W	0x00	SPOT3 TV Encoder Offset Register [5:4] SP3_TVE_PIX_OS, SPOT3 TV Encoder Pixel Offset [3:2] SP3_TVE_FLD_OS, SPOT3 TV Encoder field Offset [1] SP3_TVE_FLD_POL, SPOT3 TV Encoder Field Polarity [0] SP3_TVE_FLDDet, SPOT3 Encoder Field Detect

Address	R/W	Default	Description
0xFAA	R/W	0x00	SP3_TVE_HSENC[7:0], SPOT3 TV Encoder Active Pixel delay
0xFAB	R/W	0x00	SP3_TVE_HSENC[9:8], [7:2] SP3 Rotate Time Offset [1:0] SP3 TV Encoder Active Pixel delay
0xFAC	R/W	0x80	[7:6] SP3_CVBS_SRC_SEL [5:0] SP3_TVE_VSENC[5:0], SPOT3 TV Encoder Active Line delay
0xFAD	R/W	0x00	SP3_TVE_LINE_OS[4:0], SPOT3 TV Encoder Active Line offset
0xFAE	R/W	0x00	[7:6] SP3_FLD_SW_MODE [5:0] SP3_TVE_PIXEL_OS[5:0], SPOT3 TV Encoder Active Pixel offset
0xFAF	R/W	0x00	SP3_TVE_FLD_OS[1:0], SPOT3 TV Encoder Active Field offset
0xFB0	R/W	0x00	SP3_TVE_FSC_FREE[7], SPOT3 TV Encoder Subcarrier run free [6:0] RESERVED
0xFB1	R/W	0x00	SPOT3 OSD Enable Register [4] SP3_OSD_TITLE_EN [3] SP3_OSD_TIME_EN [2] SP3_OSD_CHPIC_EN [1] SP3_OSD_CHNUM_EN [0] SP3_OSD_OSD_EN
0xFB2	R/W	0x00	SPOT3 OSD Control Register [5] SP3_OSD_CHPIC_BLINK [4] SP3_OSD_CHPIC_TRANS [3] SP3_OSD_TITLE_MIX [2] SP3_OSD_TIME_MIX [1] SP3_OSD_CHPIC_MIX [0] SP3_OSD_CHNUM_MIX
0xFB3	R/W	0x00	[7:6] SP3_OSD_CHPIC_POS [5:4] SP3_OSD_CHNUM_POS [3:2] SP3_OSD_FONT_VSIZE [1:0] SP3_OSD_FONT_HSIZE
0xFB4	R/W	0x00	SP3_OSD_TIME_HPOS[7:0]
0xFB5	R/W	0x00	SP3_OSD_TIME_HPOS[10:8]
0xFB6	R/W	0x00	SP3_OSD_TIME_VPOS[7:0]
0xFB7	R/W	0x00	SP3_OSD_TIME_VPOS[10:8]
0xFB8	R/W	0x00	SP3_OSD_TITLE_HPOS[7:0]
0xFB9	R/W	0x00	SP3_OSD_TITLE_HPOS[10:8]
0xFBA	R/W	0x00	SP3_OSD_TITLE_VPOS[7:0]
0xFBB	R/W	0x00	SP3_OSD_TITLE_VPOS[10:8]
0xFBC	R/W	0x00	SP3_OSD_FRAME_ADDR[7:0]
0xFBD	R/W	0x00	SP3_OSD_FRAME_ADDR[10:8]
0xFBE	R/W	0x00	SP3_OSD_FRAME_DATA[7:0]
0xFBF	R/W	0x00	SP3_OSD_FRAME_DATA [15:8]
0xFC0	R/W	0x00	SP4_HTT[7:0], SPOT4 Horizontal Total Register
0xFC1	R/W	0x00	SP4_HTT[12:8], SPOT4 Horizontal Total Register
0xFC2	R/W	0x00	SP4_HDE[7:0], SPOT4 Horizontal Display Enable Register
0xFC3	R/W	0x00	SP4_HDE[11:8], SPOT4 Horizontal Display Enable Register
0xFC4	R/W	0x00	SP4_VDE[7:0], SPOT4 Vertical Display Enable Register
0xFC5	R/W	0x00	[7:4] BND_CH_EN[15:12] SPOT Border Channel Enable [2:0] SP4_VDE[10:8], SPOT4 Vertical Display Enable Register
0xFC6	R/W	0x00	SP4_HSYNC[7:0], SPOT4 Horizontal Position Sync Register
0xFC7	R/W	0x00	[3:2] SP4_FRSC [1] SP4_HBLNK[8], SPOT4 Horizontal Blank Position Register [0] SP4_HSYNC[8], SPOT4 Horizontal Sync Position Register
0xFC8	R/W	0x00	SP4_VSYNC[7:0], SPOT4 Vertical Position Sync Register
0xFC9	R/W	0x00	SP4_VTT[7:0], SPOT4 VTT register

Address	R/W	Default	Description
0xFCA	R/W	0x00	SP4_VTT[10:8], SPOT4 VTT Register [7] SP4_Half_D1 Select [2:0] SP4_VTT[10:8]
0xFCB	R/W	0x00	[5] SP4_COLORBAR, SPOT4 Color Bar Enable Register [4] SP4_BG_SW, SPOT4 Switch Background Enable Register [3:2] SP4_FLD select 11: use bank0 from the FRSC as the field 10: use bank0 from the FRSC inverse as the filed 0x: use HVCNT generated field [1] SP4_PD_EN [0] SP3_PD_EN
0xFCC	R/W	0x00	SP_USE_BY_REC_NETWORK_PORT [7:4] Select REC ports 9-0 or network to replace SP4 as display port [3:0] Select REC ports 9-0 or network to replace SP3 as display port
0xFCD	R/W	0x00	SP4_DNS DOWN SCALE Register Upper Bits [7:6] SP4 Destination Width upper bit [9:8] [5:3] SP4 Source Height upper bit [10:8] [2:0] SP4 Source Width upper bit [10:8]
0xFCE	R/W	0x00	[7] SP4 REC or Network Port Input enable [6:5] SP4 Internal Color Bar test Select [3:1] SP4 Line Buffer First line Control [0] SP4 Destination Height upper bit [8]
0xFCF	R/W	0x00	SPOT4 Enable Register [7] SP4_FLD_MODE [6] SP4_2 ND _MEM [5] SP4_FRMCNT_EN, SPOT4 Frame Count Enable [4] SP4_ENA, SPOT4 Enable [3:2] SP4_ROT_EN, SPOT4 Rotate Enable [1] SP4_VS_POL, SPOT4 Vsync Polarity Select [0] SP4_HS_POL, SPOT4 Hsync Polarity Select
0xFD0	R/W	0x00	SP4_HSTART [7:0], SPOT4 Horizontal Start Address Register
0xFD1	R/W	0x00	SP4_VSTART[7:0], SPOT4 Vertical Start Address Register
0xFD2	R/W	0x00	[7] SP4 Quad Mode Enable [5:4] SP4_HSTART[9:8], SPOT4 Horizontal Start Address Register [3:0] SP4_VSTART[11:8], SPOT4 Vertical Start Address Register
0xFD3	R/W	0x00	SP4_SRC_WID[7:0], SPOT4 Source width Register
0xFD4	R/W	0x00	SP4_SRC_HI[7:0], SPOT4 Source height Register
0xFD5	R/W	0x00	SP4_DST_WID[7:0], SPOT4 Destination width Register
0xFD6	R/W	0x00	SP4_DST_HI[7:0], SPOT4 Destination height Register
0xFD7	R/W	0x00	SPOT4 TV Encoder Standard Register [7:6] SP4_TVE_FSC_SEL, SPOT4 TV Encoder Fsc Select [5] SP4_TVE_SAT_LMT, SPOT4 TV Saturation Limit [0] SP4_TVE_STD, SPOT4 TV Standard Select
0xFD8	R/W	0x00	SPOT4 TV Encoder Standard Register [7] SP4_TVE_VSPOL, SPOT4 TV Encoder Vertical Sync Polarity [6] SP4_TVE_HSPOL, SPOT4 TV Encoder Horiz Sync Polarity [5] SP4_TVE_VSDet, SPOT4 TV Encoder Vsync detect [4] SP4_TVE_PED, SPOT4 TV Encoder Pedestal Enable [3] SP4_TVE_PDRST, SPOT4 TV Encoder Pedestal Reset [2] SP4_TVE_PHALT, SPOT4 TV Encoder Phase Alternated [1] SP4_TVE_F_INV, SPOT4 TV Encoder Field Inverted [0] SP4_TVE_INTL, SPOT4 TV Encoder Interlace Select

Address	R/W	Default	Description
0xFD9	R/W	0x00	SPOT4 TV Encoder Offset Register [5:4] SP4_TVE_PIX_OS, SPOT4 TV Encoder Pixel Offset [3:2] SP4_TVE_FLD_OS, SPOT4 TV Encoder field Offset [1] SP4_TVE_FLD_POL, SPOT4 TV Encoder Field Polarity [0] SP4_TVE_FLDDT, SPOT4 Encoder Field Detect
0xFDA	R/W	0x00	SP4_TVE_HSENC[7:0], SPOT4 TV Encoder Active Pixel delay
0xFDB	R/W	0x00	SP4_TVE_HSENC[9:8], [7:2] SP4 Rotate Time Offset [1:0] SP4 TV Encoder Active Pixel delay
0xFDC	R/W	0xC0	[7:6] SP4_CVBS_SRC_SEL [5:0] SP4_TVE_VSENC[5:0], SPOT4 TV Encoder Active Line delay
0xFDD	R/W	0x00	SP4_TVE_LINE_OS[4:0], SPOT4 TV Encoder Active Line offset
0xFDE	R/W	0x00	[7:6] SP4_FLD_SW_MODE [5:0] SP4_TVE_PIXEL_OS[5:0], SPOT4 TV Encoder Active Pixel Offset
0xFDF	R/W	0x00	SP4_TVE_FLD_OS[1:0], SPOT4 TV Encoder Active Field offset
0xFE0	R/W	0x00	SP4_TVE_FSC_FREE[7], SPOT4 TV Encoder Subcarrier run free
0xFE1	R/W	0x00	SPOT4 OSD Enable Register [4] SP4_OSD_TITLE_EN [3] SP4_OSD_TIME_EN [2] SP4_OSD_CHPIC_EN [1] SP4_OSD_CHNUM_EN [0] SP4_OSD_OSD_EN
0xFE2	R/W	0x00	SPOT4 OSD Control Register [5] SP4_OSD_CHPIC_BLINK [4] SP4_OSD_CHPIC_TRANS [3] SP4_OSD_TITLE_MIX [2] SP4_OSD_TIME_MIX [1] SP4_OSD_CHPIC_MIX [0] SP4_OSD_CHNUM_MIX
0xFE3	R/W	0x00	[7:6] SP4_OSD_CHPIC_POS [5:4] SP4_OSD_CHNUM_POS [3:2] SP4_OSD_FONT_VSIZE [1:0] SP4_OSD_FONT_HSIZE
0xFE4	R/W	0x00	SP4_OSD_TIME_HPOS[7:0]
0xFE5	R/W	0x00	SP4_OSD_TIME_HPOS[10:8]
0xFE6	R/W	0x00	SP4_OSD_TIME_VPOS[7:0]
0xFE7	R/W	0x00	SP4_OSD_TIME_VPOS[10:8]
0xFE8	R/W	0x00	SP4_OSD_TITLE_HPOS[7:0]
0xFE9	R/W	0x00	SP4_OSD_TITLE_HPOS[10:8]
0xFEA	R/W	0x00	SP4_OSD_TITLE_VPOS[7:0]
0xFEB	R/W	0x00	SP4_OSD_TITLE_VPOS[10:8]
0xFEC	R/W	0x00	SP4_OSD_FRAME_ADDR[7:0]
0xFED	R/W	0x00	SP4_OSD_FRAME_ADDR[10:8]
0xFEE	R/W	0x00	SP4_OSD_FRAME_DATA[7:0]
0xFEf	R/W	0x00	SP4_OSD_FRAME_DATA [15:8]
0xFF0	R/W	0x00	SPOT Channel0 Mapping Register [7] CHO_WR_EN [6] CHO_VSIZE_SEL [5:4] CHO_VPOS_SEL [3] CHO_HSIZE_SEL [2:0] CHO_HPOS_SEL

Address	R/W	Default	Description
0XFF1	R/W	0x00	SPOT Channel1 Mapping Register [7] CH1_WR_EN [6] CH1_VSIZE_SEL [5:4] CH1_VPOS_SEL [3] CH1_HSIZE_SEL [2:0] CH1_HPOS_SEL
0XFF2	R/W	0x00	SPOT Channel2 Mapping Register [7] CH2_WR_EN [6] CH2_VSIZE_SEL [5:4] CH2_VPOS_SEL [3] CH2_HSIZE_SEL [2:0] CH2_HPOS_SEL
0XFF3	R/W	0x00	SPOT Channel3 Mapping Register [7] CH3_WR_EN [6] CH3_VSIZE_SEL [5:4] CH3_VPOS_SEL [3] CH3_HSIZE_SEL [2:0] CH3_HPOS_SEL
0XFF4	R/W	0x00	SPOT Channel4 Mapping Register [7] CH4_WR_EN [6] CH4_VSIZE_SEL [5:4] CH4_VPOS_SEL [3] CH4_HSIZE_SEL [2:0] CH4_HPOS_SEL
0XFF5	R/W	0x00	SPOT Channel5 Mapping Register [7] CH5_WR_EN [6] CH5_VSIZE_SEL [5:4] CH5_VPOS_SEL [3] CH5_HSIZE_SEL [2:0] CH5_HPOS_SEL
0XFF6	R/W	0x00	SPOT Channel6 Mapping Register [7] CH6_WR_EN [6] CH6_VSIZE_SEL [5:4] CH6_VPOS_SEL [3] CH6_HSIZE_SEL [2:0] CH6_HPOS_SEL
0XFF7	R/W	0x00	SPOT Channel7 Mapping Register [7] CH7_WR_EN [6] CH7_VSIZE_SEL [5:4] CH7_VPOS_SEL [3] CH7_HSIZE_SEL [2:0] CH7_HPOS_SEL
0XFF8	R/W	0x00	SPOT Channel8 Mapping Register [7] CH8_WR_EN [6] CH8_VSIZE_SEL [5:4] CH8_VPOS_SEL [3] CH8_HSIZE_SEL [2:0] CH8_HPOS_SEL
0XFF9	R/W	0x00	SPOT Channel9 Mapping Register [7] CH9_WR_EN [6] CH9_VSIZE_SEL [5:4] CH9_VPOS_SEL [3] CH9_HSIZE_SEL [2:0] CH9_HPOS_SEL

Address	R/W	Default	Description
0XFFA	R/W	0x00	SPOT Channel10 Mapping Register [7] CH10_WR_EN [6] CH10_VSIZE_SEL [5:4] CH10_VPOS_SEL [3] CH10_HSIZE_SEL [2:0] CH10_HPOS_SEL
0XFFB	R/W	0x00	SPOT Channel11 Mapping Register [7] CH11_WR_EN [6] CH11_VSIZE_SEL [5:4] CH11_VPOS_SEL [3] CH11_HSIZE_SEL [2:0] CH11_HPOS_SEL
0XFFC	R/W	0x00	SPOT Channel12 Mapping Register [7] CH12_WR_EN [6] CH12_VSIZE_SEL [5:4] CH12_VPOS_SEL [3] CH12_HSIZE_SEL [2:0] CH12_HPOS_SEL
0XFFD	R/W	0x00	SPOT Channel13 Mapping Register [7] CH13_WR_EN [6] CH13_VSIZE_SEL [5:4] CH13_VPOS_SEL [3] CH13_HSIZE_SEL [2:0] CH13_HPOS_SEL
0XFFE	R/W	0x00	SPOT Channel14 Mapping Register [7] CH14_WR_EN [6] CH14_VSIZE_SEL [5:4] CH14_VPOS_SEL [3] CH14_HSIZE_SEL [2:0] CH14_HPOS_SEL
0XFFF	R/W	0x00	SPOT Channel15 Mapping Register [7] CH15_WR_EN [6] CH15_VSIZE_SEL [5:4] CH15_VPOS_SEL [3] CH15_HSIZE_SEL [2:0] CH15_HPOS_SEL

Registers

SPOT1 CONTROL REGISTER- 0XF00

Bit	R/W	Default	Description
7:0	RW	0	SP1_HTT [7:0], SPOT1 Horizontal Total Register Lower 8 bits of the SP1_HTT

SPOT1 CONTROL REGISTER- 0XF01

Bit	R/W	Default	Description
4:0	RW	0	SP1_HTT [12:8], SPOT1 Horizontal Total Register Upper 5 bits of the SP1_HTT
7:5	N/A		Reserved

SPOT1 CONTROL REGISTER- 0XF02

Bit	R/W	Default	Description
7:0	RW	0	SP1_HDE [7:0], SPOT1 Horizontal Display Enable Register Lower 8 bits of the HDE register

SPOT1 CONTROL REGISTER- 0XF03

Bit	R/W	Default	Description
7:4	N/A		Reserved
3:0	RW	0	SP1_HDE [11:8], SPOT1 Horizontal Display Enable Register Upper 4 bits of the SP1_HDE

SPOT1 CONTROL REGISTER- 0XF04

Bit	R/W	Default	Description
7:0	RW	0	SP1_VDE [7:0], SPOT1 Vertical Display Enable Register Lower 8 bits of the VDE register

SPOT1 CONTROL REGISTER- 0XF05

Bit	R/W	Default	Description
7:4	N/A	0	BND_CH_EN[3:0] Border Channel Enable
3	N/A	0	Reserved
2:0	RW	0	SP1_VDE [10:8], SPOT1 Vertical Display Enable Register Upper 3 bits of the Vertical Display Enable Register

SPOT1 CONTROL REGISTER- 0XF06

Bit	R/W	Default	Description
7:0	RW	0	SP1_HSYNC[7:0], SPOT1 Horizontal Sync register

SPOT1 CONTROL REGISTER- 0XF07

Bit	R/W	Default	Description
7:4	RW	0	BND_WIDTH_V Vertical Border Width in Field Switching Mode [7:4] SP Vertical Border Width Select
3:2	RW	0	SP1 FRSC Control 11: bank_sel equals bank_selB 10: bank_sel equals {vblank, fld} 01: bank_sel equals {bank_selA[1], fld} 00: bank_sel equals bank_selA 11: wr_page equals wr_pageB 10: wr_page equals {~vblank, 0} 01: wr_page equals {!bank_selA[1], fld} 00: wr_page equals wr_pageA
1	RW	0	SPOT FRSC No Video Control Enable to detect no in coming video to reset FRSC bank select
0	RW	0	SP1 HSYNC[8], SPOT1 Horizontal Position Sync Register Upper 1 bit of the SP1 HSYNC

SPOT1 CONTROL REGISTER- 0XF08

Bit	R/W	Default	Description
7:0	RW	x44	SP1_PVSYNC [7:0], SPOT1 Vertical Position Sync Register Lower 8 bits of the SP1_PVSYNC The register value determine when the horizontal sync start when the horizontal display counter reach to the sum of SP1_VDE and SP1_PVSYNC

SPOT1 CONTROL REGISTER- 0XF09

Bit	R/W	Default	Description
7:0	RW	0	SP1_VTT [7:0], SPOT1 VTT Register Lower 8 bits of the SP1_VTT register

SPOT1 CONTROL REGISTER- 0XF0A

Bit	R/W	Default	Description
7	RW	0	[7] SP1_Half_D1 Select
6:3	RW	0	Reserve
2:0	RW	0	[2:0] SP1_VTT[10:8]

SPOT1 CONTROL REGISTER- 0XF0B

Bit	R/W	Default	Description
7:6	RW	0	SP1 VBLANK_SEL [7:6] = 11, Select sp4 vblank as the source to the FRSC = 10, Select sp3 vblank as the source to the FRSC = 01, Select sp2 vblank as the source to the FRSC = 00, Select sp1 vblank as the source to the FRSC
5	RW	0	SP1 COLOR BAR ENA
4	RW	0	SP1_SWITCH_EN 0: Background enable 1: Background display disable
3:2	RW	0	SP1_FLD select 11: use bank0 from the FRSC as the field 10: use bank0 from the FRSC inverse as the field 0x: use HVCNT generated field
1:0	RW	0	Reserved

SPOT1 CONTROL REGISTER- 0XF0C

Bit	R/W	Default	Description
7:0	RW	0	SP_ROT_INT_EN [7] SP4 Rot Int status [6] SP3 Rot Int status [5] SP2 Rot Int status [4] SP1 Rot Int status [3] SP4 Rot Int Enable [2] SP3 Rot Int Enable [1] SP2 Rot Int Enable [0] SP1 Rot Int Enable

SPOT1 CONTROL REGISTER - 0XF0D

Bit	R/W	Default	Description
7:0	RW	0	SP1_DNS Upper Bits [7:6] SP1 Destination Width upper bit [9:8] [5:3] SP1 Source Height upper bit [10:8] [2:0] SP1 Source Width upper bit [10:8]

SPOT1 CONTROL REGISTER - 0XF0E

Bit	R/W	Default	Description
7	RW	0	SP1 REC or Network port Enable Enable the REC or Network port to use SP1 as display
6:4	RW	0	SP1 Color Bar Select
3:1	RW	0	SP1_Firsr Line_Control
0	RW	0	SP1 Destination Height Upper Bit [8]

SPOT1 CONTROL REGISTER – 0XF0F

Bit	R/W	Default	Description
7	N/A	1	SP1_Field Mode Select 1: Field mode 0: Frame mode
6	RW	0	SP1_2 ND _MEM Enable
5	RW	0	SP1_FRMCNT_EN SPOT1 Frame Count Enable
4	RW	0	SP1_ENA SPOT1 Enable
3:2	RW	0	SP1_ROT Rotation Enable
1	RW	0	SP1_VSPOL SPOT1 Vertical Sync Polarity Control
0	RW	0	SP1_HSPOL SPOT1 Horizontal Sync Polarity Control

SPOT1 CONTROL REGISTER – 0XF10

Bit	R/W	Default	Description
7:0	RW	00	SP1_HSTART [7:0], SPOT1 Horizontal Start Register This register determines the lower 8 bits of SPOT1 Horizontal start address

SPOT1 CONTROL REGISTER – 0XF11

Bit	R/W	Default	Description
7:0	RW	01	SP1_VSTART [7:0], SPOT1 Vertical Start Register This register determines the lower 8 bits of SPOT1 Vertical start address

SPOT1 CONTROL REGISTER – 0XF12

Bit	R/W	Default	Description
7	N/A	0	SP1 Quad Mode Enable When Enable, the SP1 memory controller will read half of each line data and start a new address calculation from second half line as well as half field for the vertical address to prevent whole screen jumping when weak video is presence. This bit should set to one when screen image is set to quad mode.
6	N/A		Reserved
5:4	RW	0	SP1_HSTART [9:8], SPOT1 Horizontal Start Register Upper 2 bits of the SPOT1 Horizontal start register in 4 pixels / unit
3:0	RW	0	SP1_VSTART [11:8], SPOT1 Vertical Start Register Upper 4 bits of the SPOT1 Vertical start register in 1 line / unit

SPOT1 CONTROL REGISTER – 0XF13

Bit	R/W	Default	Description
7:0	RW	00	SP1_SRC_WID [7:0], SPOT1 Down Scale Source Width Register This register determines the source width of the image. The upper 3 bits are in register 0xF0D.

SPOT1 CONTROL REGISTER– 0XF14

Bit	R/W	Default	Description
7:0	RW	00	SP1_SRC_HI [7:0], SPOT1 Down Scale Source Height Register This register determines the source height of the image. The upper 3 bits are in register 0xF0D.

SPOT1 CONTROL REGISTER – 0XF15

Bit	R/W	Default	Description
7:0	RW	00	SP1_DST_WID [7:0], SPOT1 Down Scale Destination Width Register This register determines the source width of the image. The upper 2 bits are in register 0xF0D.

SPOT1 CONTROL REGISTER– 0XF16

Bit	R/W	Default	Description
7:0	RW	00	SP1_DST_HI [7:0], SPOT1 Down Scale Destination Height Register This register determines the source height of the image. The upper 1 bit is in register 0xF0E.

SPOT1 CONTROL REGISTER– 0XF17

Bit	R/W	Default	Description
7:6	RW	0	TVENC_FSC_MODE, SPOT1 TV FSCSEL This register determines the TV modulation frequency standard select. 00 - NTSC M 01 - PAL B, D, G, H, I 10 - PAL M 11 - PAL N
5	RW	0	TVENC_SAT_LMT, SPOT1 TV video saturation limit Control the data range of the ITU-R BT 656 output 0 - Not limit 1 - Data range is limited to 1 - 254 range
4:1	RW	0	Reserved

Bit	R/W	Default	Description
0	RW	0	<p>TVENC_PALNT, SPOT1 TV PAL or NTSC select</p> <p>This register determines the CVBS output Standard.</p> <p>0: NSTC mode 1: PAL mode.</p>

SPOT1 CONTROL REGISTER- 0XF18

Bit	R/W	Default	Description
7	RW	0	<p>SP1_TVENC_VSPOL, SPOT1 TVENC Vertical sync polarity</p> <p>0: Active Low 1: Active High</p>
6	RW	0	<p>SP1_TVENC_HSPOL, SPOT1 TV Encoder Horizontal Sync Polarity</p> <p>0: Active Low 1: Active High</p>
5	RW	0	<p>SP1_TVENC_VSDDET, SPOT1 TV Encoder Vsync detain select</p> <p>This bit is used by TV encoder as an option to generate an reset by using vsync or field signals.</p> <p>If this bit is 1, the reset sync generated from field signal. If this bit is 0, the reset sync generated from the vsync signal.</p>
4	RW	0	<p>SP1_TVENC_PED, SPOT1 TV Encoder Pedestal Enable</p> <p>Enable Pedestal for video output</p> <p>0: 0 IRE for pedestal 1: 7.5 IRE pedestal level</p>
3	RW	0	<p>SP1_TVENC_PDRST, SPOT1 TV Encoder Pedestal Reset</p> <p>Subcarrier Phase Alternation reset every 8 field in PAL system</p> <p>0: Constant relationship, reset every 8 field 1: Free running</p>
2	RW	0	<p>SP1_TVENC_PHALT, SPOT1 TV Encoder Phase Alternation</p> <p>0: Disable phase alternation for line by line. Use in NTSC 1: Enable phase alternation for line by line. Use in PAL</p>
1	RW	0	<p>SP1_TVENC_F_INV, SPOT1 TV Encoder Field Output Invert</p> <p>This register bit inverts the field output level if set.</p>
0	RW	0	<p>SP1_TVENC_INTERLACE, SPOT1 TVENC Interlace Select</p> <p>This register bit determines the TV Standard in Interlace timing mode.</p> <p>0 - Progressive 1 - Interlace</p>

SPOT1 CONTROL REGISTER- 0XF19

Bit	R/W	Default	Description
7:6	N/A		Reserved
5:4	RW	0	SP1_TVENC_YC_OS[1:0], SPOT1 TV Encoder Active Pixel Offset delay 00: No Active offset 01: Active pixel offset for 1/4 pixel unit 10: Active pixel offset for 1/2 pixel unit 11: Active pixel offset for 3/4 pixel unit
3:2	RW	0	SP1_TVENC_OSENC[1:0], SPOT1 TV Encoder Field Offset for the first video line 00: Apply same ENC_VDSEL for odd and even field 01: Apply same ENC_VDSEL for odd and odd field 10: Apply TVENC_VSDEL for odd field and TVENC_VSDEL+1 for even field 11: Apply TVENC_VSDEL for odd field and TVENC_VSDEL+2 for even field
1	RW	0	SP1_TVENC_FLDENCP, SPOT1 TV Encoder Field Polarity This Register control the field polarity 0: Even field is high 1: Odd field is high
0	RW	0	SP1_TVENC_FLDDDET, SPOT1 TV Encoder Field Detect

SPOT1 CONTROL REGISTER- 0XF1A

Bit	R/W	Default	Description
7:0	RW	0	SP1_TVENC_HSENC[7:0], SPOT1 TV Encoder Active pixel delay Lower 8 bits of the pixel delay from active video by 1/2 pixel per step

SPOT1 CONTROL REGISTER- 0XF1B

Bit	R/W	Default	Description
7:2	N/A	0	SP1_Rotate_Time_Offset
1:0	RW	0	SP1_TVENC_HSENC[9:8], SPOT1 TV Encoder Active pixel delay Upper 2 bits of the pixel delay from active video by 1/2 pixel per step

SPOT1 CONTROL REGISTER- 0XF1C

Bit	R/W	Default	Description
7:6	N/A	0	SP1_CVBS_SEL 11 : SP1 CVBS output is coming from SP4 10 : SP1 CVBS output is coming from SP3 01 : SP1 CVBS output is coming from SP2 00 : SP1 CVBS output is coming from SP1
5:0	RW	0	SP1_TVENC_VSENC, SPOT1 TV Encoder Active line delay 6 bits of the line delay from active video by line per step

SPOT1 CONTROL REGISTER- 0XF1D

Bit	R/W	Default	Description
-----	-----	---------	-------------

7:6	N/A		Reserved
4:0	RW	0	SP1_TVENC_LINE_OS, SPOT1 TV Encoder Active line offset 5 bits of the line offset

SPOT1 CONTROL REGISTER- 0XF1E

Bit	R/W	Default	Description
7:6	N/A	0	[7;6] SP1_FLD_SW_MODE [7] Field Switching Mode enable [6] Field Switch Mode image height is 240 lines Enable
5:0	RW	0	SP1_TVENC_PIXEL_OS, SPOT1 TV Encoder Active Pixel offset 6 bits of the pixel offset

SPOT1 CONTROL REGISTER- 0XF1F

Bit	R/W	Default	Description
7	N/A		Reserved
6	RW	0	SP1_TVENC_C_OFF_D, SPOT1 TV Encoder C Off Set the Color Off if set
5:4	RW	0	SP1_TVENC_CBW_D, SPOT1 TV Encoder CbCr delay 2 bits of the CbCr delay
3:2	RW	0	SP1_TVENC_YBW_D, SPOT1 TV Encoder Luma delay 2 bits of the Luminous delay
1:0	RW	0	SP1_TVENC_FLD_OS, SPOT1 TV Encoder Active Field offset 2 bits of the field offset

SPOT1 CONTROL REGISTER- 0XF20

Bit	R/W	Default	Description
7	RW	0	SP1_TVENC_TST_FSC_FREE, SPOT1 TV Encoder Sub-Carrier is set to free run
6	RW	0	SP1_TVENC_T_CCIR_TIM, SPOT1 TV Encoder CCOR Timing 2 bits of the CbCr delay
5	RW	0	SP1_TVENC_T_656_STD, SPOT1 TV Encoder 656 Standard 2 bits of the Luminous delay
4:0	RW	0	SP1_TVENC_VIS_LINE_OS, SPOT1 TV Encoder line offset 5 bits Line offset

SPOT CONTROL REGISTER- 0XF21

Bit	R/W	Default	Description
-----	-----	---------	-------------

7:0	N/A	0	<p>Vertical Start Address offset [7:0] in 256 or 512 Mb memory Config.</p> <p>In 128Mb config, the SPOT can only read 4 D1 Images written in the memory, when the Record memory size increased to 256 Mb, SPOT write can store 4 more D1 images in SDRAM, to read these images, we need to set the SP_{1,2,3,4} VSTART address together with this address offset registers to match the SPOT write address to get the correct images.</p> <p>To use this features, SP_x2ND_MEM bit need to set to 1.</p>
-----	-----	---	---

SPOT CONTROL REGISTER- 0XF22

Bit	R/W	Default	Description
7:0	RW	0	<p>BACKGROUND Pr, SPOT Background Color Red Color</p> <p>8 bits Red color value</p>

SPOT CONTROL REGISTER- 0XF23

Bit	R/W	Default	Description
7:0	RW	0	<p>BACKGROUND Y, SPOT Background Color Green Color</p> <p>8 bits Green color value</p>

SPOT CONTROL REGISTER- 0XF24

Bit	R/W	Default	Description
7:0	RW	0	<p>BACKGROUND Pb, SPOT Background Color Blue Color</p> <p>8 bits Blue color value</p>

SPOT CONTROL REGISTER- 0XF25

Bit	R/W	Default	Description
7	RW	0	SWITCH_EN, For test purpose
6	RW	0	COLBAR_EN, For test purpose
5	RW	0	Reserve
4	RW	0	BND_EN[0], SPOT Border Width Enable bit 0
3:0	RW	0	<p>BORDER_WIDTH, SPOT Border Width Select</p> <p>4 bits Border Width Select</p>

SPOT CONTROL REGISTER- 0XF26

Bit	R/W	Default	Description
7:0	RW	0	<p>BND_Pr, SPOT Border Red Color</p> <p>8 bits Red color value</p>

SPOT CONTROL REGISTER- 0XF27

Bit	R/W	Default	Description
-----	-----	---------	-------------

7:0	RW	0	BND_Y, SPOT Border Green Color 8 bits Green color value
-----	----	---	---

SPOT CONTROL REGISTER - 0XF28

Bit	R/W	Default	Description
7:0	RW	0	BND_Pb, SPOT Border Blue Color 8 bits Blue color value

SPOT CONTROL REGISTER - 0XF29

Bit	R/W	Default	Description
7:0	RW	0	ROT_FREQ, SPOT Channel Rotate Frequency 8 bits Rotate Frequency Control in field / unit

SPOT2 CONTROL REGISTER - 0XF2A

Bit	R/W	Default	Description
7:0	RW	0	SP2_OSD_DRAM_ADDR

SPOT2 CONTROL REGISTER - 0XF2B

Bit	R/W	Default	Description
7:6	RW		Reserve
5:0	RW	0	SP2_OSD_DRAM_DATA

SPOT3 CONTROL REGISTER - 0XF2C

Bit	R/W	Default	Description
7:0	RW	0	SP3_OSD_DRAM_ADDR

SPOT3 CONTROL REGISTER - 0XF2D

Bit	R/W	Default	Description
7:6	RW		Reserve
5:0	RW	0	SP3_OSD_DRAM_DATA

SPOT4 CONTROL REGISTER - 0XF2E

Bit	R/W	Default	Description
7:0	RW	0	SP4_OSD_DRAM_ADDR

SPOT4 CONTROL REGISTER – 0XF2F

Bit	R/W	Default	Description
7:6	RW		Reserve
5:0	RW	0	SP4_OSD_DRAM_DATA

SPOT1 CONTROL REGISTER – 0XF30

Bit	R/W	Default	Description
7:5	RW	0	BND_EN[3:1] SPOT Border Enable for each channel Display Border enable for channel 4, channel 3, and channel 2 [7] : channel 4 [6] : channel 3 [5] : channel 2 1: enable 0: disable
4	RW	0	SP1_OSD_TITLE_EN Display title enable 1: enable 0: disable
3	RW	0	SP1_OSD_TIME_EN Display time and date enable 1: enable 0: disable
2	RW	0	SP1_OSD_CHPIC_EN Display picture for each channel 1: enable 0: disable
1	RW	0	SP1_OSD_CHNUM_EN Display channel number for each channel 1: enable 0: disable
0	RW	0	SP1_OSD_EN All OSD information enable or disable. If set to 1, each information is enabled by bit [4:1]. If set to 0, all OSD is disabled. 1: enable 0: disable

SPOT1 CONTROL REGISTER – 0XF31

Bit	R/W	Default	Description
7:6	RW	0	Reserved
5	RW	0	SP1_OSD_CHPIC_BLINK If set to 1, picture for each channel blink in picture index 2 and 3. Picture 0 and 1 will not blink 1: enable 0: disable
4	RW	0	SP1_OSD_CHPIC_TRANS If set to 1, picture in color index "00" will be transparent 1: enable 0: disable
3	RW	0	SP1_OSD_TITLE_MIX Display title mix enable bit. If set to 1, title will be 50% blending with video 1: enable 0: disable
2	RW	0	SP1_OSD_TIME_MIX Display time and date mix enable bit. If set to 1, time/date will be 50% blending with video 1: enable 0: disable
1	RW	0	SP1_OSD_CHPIC_MIX Display picture mix enable bit. If set to 1, picture will be 50% blending with video 1: enable 0: disable
0	RW	0	SP1_OSD_CHNUM_MIX Display channel number information mix enable bit. If set to 1, channel information will be 50% blending with video 1: enable 0: disable

SPOT1 OSD FONT SIZE REGISTER – 0XF32

Bit	R/W	Default	Description
7:6	RW	0x1	SP1_OSD_CHPIC_POS Channel picture corner position. 00: left top 01: right top 10: left bottom 11: right bottom
5:4	RW	0	SP1_OSD_CHNUM_POS Channel number corner position. 00: left top 01: right top 10: left bottom 11: right bottom
3:2	RW	0x3	SP1_OSD_FONT_VSIZE Font vertical size for display. There are four choices. 00: 8 01: 10 10: 16, scale up from 8 11: 20, scale up from 10
1:0	RW	0x3	SP1_OSD_FONT_HSIZE Font horizontal size for display. There are four choices. 00: 6 01: 8 10: 12, scale up from 6 11: 16, scale up from 8

SPOT1 OSD CHANNEL NUMBER HORIZONTAL POSITION LOW BYTE REGISTER – 0XF33

Bit	R/W	Default	Description
7:0	RW	0	SP1_OSD_CHNUM_HPOS[7:0] Channel number information horizontal position offset to each channel horizontal start position. It is one pixel unit.

SPOT1 OSD CHANNEL NUMBER HORIZONTAL POSITION HIGH BYTE REGISTER – 0XF34

Bit	R/W	Default	Description
2:0	RW	0	SP1_OSD_CHNUM_HPOS[10:8] Channel number information horizontal position offset to each channel horizontal start position. It is one pixel unit.

SPOT1 OSD CHANNEL NUMBER VERTICAL POSITION LOW BYTE REGISTER – 0XF35

Bit	R/W	Default	Description
7:0	RW	0	SP1_OSD_CHNUM_VPOS[7:0] Channel number information vertical position offset to each channel vertical start position. It is one pixel unit.

SPOT1 OSD CHANNEL NUMBER HORIZONTAL POSITION HIGH BYTE REGISTER – 0XF36

Bit	R/W	Default	Description
7:3	RW	0	<p>SP1_FRC_CTL[4:0]</p> <p>[4] Auto Correction Jumps two field when set to 1. One field if this bit set to 0.</p> <p>[3] Enable Correction</p> <p>[2:0] Select one of quad spot wr pages as reference 0: Select spot wr page 0,1,2,3 1: Select spot wr page 4,5,6,7 2: Select spot wr page 7,8,9,10 3: Select spot wr page 11,12,13,14 4-7: use quad position to select as reference</p>
2:0	RW	0	<p>SP1_OSD_CHNUM_VPOS[10:8]</p> <p>Channel number information vertical position offset to each channel vertical start position. It is one pixel unit.</p>

SPOT1 OSD CHANNEL PICTURE HORIZONTAL POSITION LOW BYTE REGISTER – 0XF37

Bit	R/W	Default	Description
7:0	RW	0	<p>SP1_OSD_CHPIC_HPOS[7:0]</p> <p>Channel picture information horizontal position offset to each channel horizontal start position. It is one pixel unit.</p>

SPOT1 OSD CHANNEL PICTURE HORIZONTAL POSITION HIGH BYTE REGISTER – 0XF38

Bit	R/W	Default	Description
7:3	RW	0	<p>SP2_FRC_CTL[4:0]</p> <p>[4] Auto Correction Jumps two field when set to 1. One field if this bit set to 0.</p> <p>[3] Enable Correction</p> <p>[2:0] Select one of quad spot wr pages as reference 0: Select spot wr page 0,1,2,3 1: Select spot wr page 4,5,6,7 2: Select spot wr page 7,8,9,10 3: Select spot wr page 11,12,13,14 4-7: use quad position to select as reference</p>
2:0	RW	0	<p>SP1_OSD_CHPIC_HPOS[10:8]</p> <p>Channel picture information horizontal position offset to each channel horizontal start position. It is one pixel unit.</p>

SPOT1 OSD CHANNEL PICTURE VERTICAL POSITION LOW BYTE REGISTER – 0XF39

Bit	R/W	Default	Description
7:0	RW	0	<p>SP1_OSD_CHPIC_VPOS[7:0]</p> <p>Channel picture information vertical position offset to each channel vertical start position. It is one pixel unit.</p>

SPOT1 OSD CHANNEL PICTURE HORIZONTAL POSITION HIGH BYTE REGISTER – 0XF3A

Bit	R/W	Default	Description
7:3	RW	0	SP3_FRC_CTL[4:0] [4] Auto Correction Jumps two field when set to 1. One field if this bit set to 0. [3] Enable Correction [2:0] Select one of quad spot wr pages as reference 0: Select spot wr page 0,1,2,3 1: Select spot wr page 4,5,6,7 2: Select spot wr page 7,8,9,10 3: Select spot wr page 11,12,13,14 4-7: use quad position to select as reference
2:0	RW	0	SP1_OSD_CHPIC_VPOS[10:8] Channel number information vertical position offset to each channel vertical start position. It is one pixel unit.

SPOT1 OSD TIME AND DATE HORIZONTAL POSITION LOW BYTE REGISTER – 0XF3B

Bit	R/W	Default	Description
7:0	RW	0	SP1_OSD_TIME_HPOS[7:0] Time and Date information horizontal position. It is one pixel unit.

SPOT1 OSD TIME AND DATE HORIZONTAL POSITION HIGH BYTE REGISTER – 0XF3C

Bit	R/W	Default	Description
7:3	RW	0	SP4_FRC_CTL[4:0] [4] Auto Correction Jumps two field when set to 1. One field if this bit set to 0. [3] Enable Correction [2:0] Select one of quad spot wr pages as reference 0: Select spot wr page 0,1,2,3 1: Select spot wr page 4,5,6,7 2: Select spot wr page 7,8,9,10 3: Select spot wr page 11,12,13,14 4-7: use quad position to select as reference
2:0	RW	0	SP1_OSD_TIME_HPOS[10:8] Time and Date information horizontal position. It is one pixel unit.

SPOT1 OSD TIME AND DATE VERTICAL POSITION LOW BYTE REGISTER – 0XF3D

Bit	R/W	Default	Description
7:0	RW	0	SP1_OSD_TIME_VPOS[7:0] Time and Date information vertical position. It is one pixel unit.

SPOT1 OSD TIME AND DATE HORIZONTAL POSITION HIGH BYTE REGISTER – 0XF3E

Bit	R/W	Default	Description
2:0	RW	0	SP1_OSD_TIME_VPOS[10:8] Time and Date information vertical position. It is one pixel unit.

SPOT1 OSD TITLE HORIZONTAL POSITION LOW BYTE REGISTER – 0XF3F

Bit	R/W	Default	Description
7:0	RW	0	SP1_OSD_TITLE_HPOS[7:0] Title information horizontal position. It is one pixel unit.

SPOT1 OSD TITLE HORIZONTAL POSITION HIGH BYTE REGISTER – 0XF40

Bit	R/W	Default	Description
2:0	RW	0	SP1_OSD_TITLE_HPOS[10:8] Title information horizontal position. It is one pixel unit.

SPOT1 OSD TITLE VERTICAL POSITION LOW BYTE REGISTER – 0XF41

Bit	R/W	Default	Description
7:0	RW	0	SP1_OSD_TITLE_VPOS[7:0] Title information vertical position. It is one pixel unit.

SPOT1 OSD TITLE HORIZONTAL POSITION HIGH BYTE REGISTER – 0XF42

Bit	R/W	Default	Description
2:0	RW	0	SP1_OSD_TITLE_VPOS[10:8] Title information vertical position. It is one pixel unit.

SPOT OSD FONT RED COLOR 1 REGISTER – 0XF43

Bit	R/W	Default	Description
7:0	RW	0	SP_OSD_FONT_PR1[7:0] Font red color for color index 1.

SPOT OSD FONT GREEN COLOR 1 REGISTER – 0XF44

Bit	R/W	Default	Description
7:0	RW	0	SP_OSD_FONT_Y1[7:0] Font green color for color index 1.

SPOT OSD FONT BLUE COLOR 1 REGISTER – 0XF45

Bit	R/W	Default	Description
7:0	RW	0	SP_OSD_FONT_PB1[7:0] Font blue color for color index 1.

SPOT OSD FONT RED COLOR 2 REGISTER – 0XF46

Bit	R/W	Default	Description
7:0	RW	0	SP_OSD_FONT_PR2[7:0] Font red color for color index 2.

SPOT OSD FONT GREEN COLOR 2 REGISTER – 0XF47

Bit	R/W	Default	Description
7:0	RW	0	SP_OSD_FONT_Y2[7:0] Font green color for color index 2.

SPOT OSD FONT BLUE COLOR 2 REGISTER – 0XF48

Bit	R/W	Default	Description
7:0	RW	0	SP_OSD_FONT_PB2[7:0] Font blue color for color index 2.

SPOT OSD FONT RED COLOR 3 REGISTER – 0XF49

Bit	R/W	Default	Description
7:0	RW	0	SP_OSD_FONT_PR3[7:0] Font red color for color index 3.

SPOT OSD FONT GREEN COLOR 3 REGISTER – 0XF4A

Bit	R/W	Default	Description
7:0	RW	0	SP_OSD_FONT_Y3[7:0] Font green color for color index 3.

SPOT OSD FONT BLUE COLOR 3 REGISTER – 0XF4B

Bit	R/W	Default	Description
7:0	RW	0	SP_OSD_FONT_PB3[7:0] Font blue color for color index 3.

SPOT OSD PICTURE RED COLOR 0 REGISTER – 0XF4C

Bit	R/W	Default	Description
7:0	RW	0	SP_OSD_PIC_PRO[7:0] Picture red color for color index 0.

SPOT OSD PICTURE GREEN COLOR 0 REGISTER – 0XF4D

Bit	R/W	Default	Description
7:0	RW	0	SP_OSD_PIC_Y0[7:0] Picture green color for color index 0.

SPOT OSD PICTURE BLUE COLOR 0 REGISTER – 0XF4E

Bit	R/W	Default	Description
7:0	RW	0	SP_OSD_PIC_PBO[7:0] Picture blue color for color index 0.

SPOT OSD PICTURE RED COLOR 1 REGISTER – 0XF4F

Bit	R/W	Default	Description
7:0	RW	0	SP_OSD_PIC_PR1[7:0] Picture red color for color index 1.

SPOT OSD PICTURE GREEN COLOR 1 REGISTER – 0XF50

Bit	R/W	Default	Description
7:0	RW	0	SP_OSD_PIC_Y1[7:0] Picture green color for color index 1.

SPOT OSD PICTURE BLUE COLOR 1 REGISTER – 0XF51

Bit	R/W	Default	Description
7:0	RW	0	SP_OSD_PIC_PB1[7:0] Picture blue color for color index 1.

SPOT OSD PICTURE RED COLOR 2 REGISTER – 0XF52

Bit	R/W	Default	Description
7:0	RW	0	SP_OSD_PIC_PR2[7:0] Picture red color for color index 2.

SPOT OSD PICTURE GREEN COLOR 2 REGISTER – 0XF53

Bit	R/W	Default	Description
7:0	RW	0	SP_OSD_PIC_Y2[7:0] Picture green color for color index 2.

SPOT OSD PICTURE BLUE COLOR 2 REGISTER – 0XF54

Bit	R/W	Default	Description
7:0	RW	0	SP_OSD_PIC_PB2[7:0] Picture blue color for color index 2.

SPOT OSD PICTURE RED COLOR 3 REGISTER – 0XF55

Bit	R/W	Default	Description
7:0	RW	0	SP_OSD_PIC_PR3[7:0] Picture red color for color index 3.

SPOT OSD PICTURE GREEN COLOR 3 REGISTER – 0XF56

Bit	R/W	Default	Description
7:0	RW	0	SP_OSD_PIC_Y3[7:0] Picture green color for color index 3.

SPOT OSD PICTURE BLUE COLOR 3 REGISTER – 0XF57

Bit	R/W	Default	Description
7:0	RW	0	SP1_OSD_PIC_PB3[7:0] Picture blue color for color index 3.

SPOT1 OSD FONT AND PICTURE RAM ADDRESS LOW BYTE REGISTER – 0XF58

Bit	R/W	Default	Description
7:0	RW	0	SP1_OSD_FRAM_ADDR[7:0] Font and Picture SRAM address. When host write data to this SRAM, address is written first and then data. SRAM size is 1152x16. Font size is 640x16, Picture size is 512x16.

SPOT1 OSD FONT AND PICTURE RAM ADDRESS HIGH BYTE REGISTER – 0XF59

Bit	R/W	Default	Description
2:0	RW	0	SP1_OSD_FRAM_ADDR[10:8] Font and Picture SRAM address. When host write data to this SRAM, address is written first and then data. SRAM size is 1152x16. Font size is 640x16, Picture size is 512x16.

SPOT1 OSD FONT AND PICTURE RAM DATA LOW BYTE REGISTER – 0XF5A

Bit	R/W	Default	Description
7:0	RW	0	SP1_OSD_FRAM_DATA[7:0] Font and Picture SRAM address. When host write data to this SRAM, address is written first and then data. SRAM size is 1152x16. Font size is 640x16, Picture size is 512x16.

SPOT1 OSD FONT AND PICTURE RAM DATA HIGH BYTE REGISTER – 0XF5B

Bit	R/W	Default	Description
7:0	RW	0	SP1_OSD_FRAM_DATA[15:8] Font and Picture SRAM address. When host write data to this SRAM, address is written first and then data. SRAM size is 1152x16. Font size is 640x16, Picture size is 512x16.

SPOT1 OSD DISPLAY RAM ADDRESS REGISTER – 0XF5C

Bit	R/W	Default	Description
7:0	RW	0	SP1_OSD_DRAM_ADDR[7:0] Display SRAM address. When host write data to this SRAM, address is written first and then data. SRAM size is 244x6. Channel number size is 160x6, time/date size is 32x6, title size is 32x6 and picture index size is 20x6.

SPOT1 OSD DISPLAY RAM DATA REGISTER – 0XF5D

Bit	R/W	Default	Description
7:6	RW		Reserve
5:0	RW	0	SP1_OSD_DRAM_Data[5:0] Display SRAM Data. When host write data to this SRAM, address is written first and then data. SRAM size is 244x6. Channel number size is 160x6, time/date size is 32x6, title size is 32x6 and picture index size is 20x6.

SPOT DISP_PITCH REGISTER – 0XF5E

Bit	R/W	Default	Description
7:0	RW	0	SPOT_DISP_PITCH Display Pitch register for SDRAM linear address. In 16 pixels / unit

SPOT ADJUSTMENT ENABLE REGISTER – 0XF5F

Bit	R/W	Default	Description
7:0	RW	0	SPOT_ADJUST_ENA Display Adjust Enable register

SPOT2 CONTROL REGISTER – 0XF60

Bit	R/W	Default	Description
7:0	RW	0	SP2_HTT [7:0], SPOT2 Horizontal Total Register Lower 8 bits of the SP2_HTT

SPOT2 CONTROL REGISTER – 0XF61

Bit	R/W	Default	Description
7:5	N/A		Reserved
4:0	RW	0	SP2_HTT [12:8], SPOT2 Horizontal Total Register Upper 5 bits of the SP2_HTT

SPOT1 CONTROL REGISTER – 0XF62

Bit	R/W	Default	Description
7:0	RW	0	SP2_HDE [7:0], SPOT2 Horizontal Display Enable Register Lower 8 bits of the HDE register

SPOT2 CONTROL REGISTER – 0XF63

Bit	R/W	Default	Description
7:4	N/A		Reserved
3:0	RW	0	SP2_HDE [11:8], SPOT2 Horizontal Display Enable Register Upper 4 bit of the SP2_HDE

SPOT2 CONTROL REGISTER – 0XF64

Bit	R/W	Default	Description
7:0	RW	0	SP2_VDE [7:0], SPOT2 Vertical Display Enable Register Lower 8 bits of the VDE register

SPOT2 CONTROL REGISTER – 0XF65

Bit	R/W	Default	Description
7:4	N/A	0	BND_CH_EN[7:4] Border Channel Enable
3	N/A	0	Reserved
2:0	RW	0	SP2_VDE [11:8], SPOT2 Vertical Display Enable Register Upper 3 bits of the Vertical Display Enable Register

SPOT2 CONTROL REGISTER – 0XF66

Bit	R/W	Default	Description
7:0	RW	0	SP2_PHSYNC [7:0], SPOT2 Horizontal Position Sync Register Lower 8 bits of the SP2_PHSYNC The register value determine when the horizontal sync start when the horizontal display counter reach to the sum of SP2_HDE and SP2_PHSYNC

SPOT2 CONTROL REGISTER – 0XF67

Bit	R/W	Default	Description
7:4	N/A	0	BND_WIDTH_SEL in Vertical Border in Field Switching Mode [7] SP4 Border Select [6] SP3 Border Select [5] SP2 Border Select [4] SP1 Border Select
3:2	RW	0	SP2 FRSC Control 11: bank_sel equals bank_selB 10: bank_sel equals {vblank, fld} 01: bank_sel equals {bank_selA[1], fld} 00: bank_sel equals bank_selA 11: wr_page equals wr_pageB 10: wr_page equals {~vblank, 0} 01: wr_page equals {!bank_selA[1], fld} 00: wr_page equals wr_pageA
1	RW	0	Reserve
0	RW	0	SP2_PHSYNC[8], SPOT2 Horizontal Position Sync Register Upper 1 bit of the SP2_PHSYNC

SPOT2 CONTROL REGISTER – 0XF68

Bit	R/W	Default	Description
7:0	RW	0	SP2_PVSYNC [7:0], SPOT2 Vertical Position Sync Register Lower 8 bits of the SP2_PVSYNC The register value determine when the horizontal sync start when the horizontal display counter reach to the sum of SP2_VDE and SP2_PVSYNC

SPOT2 CONTROL REGISTER – 0XF69

Bit	R/W	Default	Description
7:0	RW	0	SP2_VTT [7:0], SPOT2 VTT Register Lower 8 bits of the SP2_VTT register

SPOT2 CONTROL REGISTER – 0XF6A

Bit	R/W	Default	Description
7	RW	0	[7] SP2_Half_D1 Select
6	RW	0	Reserve
5:4	RW	0	Select SPOT CVBS out to network port 00: Sel SPOT1 01: Sel SPOT2 10: Sel SPOT3 11: Sel SPOT4
3	RW	0	Reserve
2:0	RW	0	[2:0] SP2_VTT[10:8] Upper 3 bits of the SP2_VTT

SPOT2 CONTROL REGISTER – 0XF6B

Bit	R/W	Default	Description
7:6	RW	0	SP2 VBLANK_SEL
5	RW	0	SP2 COLOR BAR ENA
4	RW	0	SP2_SWITCH_EN 0: Background enable 1: Background display disable
3:2	RW	0	SP2_FLD select 11: use bank0 from the FRSC as the field 10: use bank0 from the FRSC inverse as the filed 0x: use HVCNT generated field
1:0	RW	0	Reserve

SPOT2 CONTROL REGISTER – 0XF6C

Bit	R/W	Default	Description
7:0	RW	0	SPOT Rotate Count [7:6] SP4 rotate count [5:4] SP3 rotate count [3:2] SP2 rotate count [1:0] SP1 rotate count

SPOT2 CONTROL REGISTER – 0XF6D

Bit	R/W	Default	Description
7:0	RW	0	SP2_DNS Upper Bits [7:6] SP2 Destination Width upper bit [9:8] [5:3] SP2 Source Height upper bit [10:8] [2:0] SP2 Source Width upper bit [10:8]

SPOT2 CONTROL REGISTER – 0XF6E

Bit	R/W	Default	Description
7	RW	0	SP2 REC or Network port Enable Enable the REC or Network port to use SP2 as display

Bit	R/W	Default	Description
6:4	RW	0	SP2 color bar select
3:1	RW	0	SP2_Firsrt_line_control
0	RW	0	SP2 Destination Height upper bit [8] in down scale ratio

SPOT2 CONTROL REGISTER - 0XF6F

Bit	R/W	Default	Description
7	RW	1	SP2_Field Mode Select 1: Field mode 0: Frame mode
6		0	SP2_2 ND _MEM Enable
5		0	SP2_FRMCNT_EN SPOT2 Frame Count Enable
4		0	SP2_ENA SPOT2 Enable
3:2	RW	0	SP2_ROT Rotation Enable
1	RW	0	SP2_VSPOL SPOT2 Vertical Polarity Control
0	RW	0	SP2_HSPOL SPOT2 Horizontal Polarity Control

SPOT2 CONTROL REGISTER - 0XF70

Bit	R/W	Default	Description
7:0	RW	00	SP2_HSTART [7:0], SPOT2 Horizontal Start Register This register determines the lower 8 bits of SPOT2 Horizontal start address

SPOT2 CONTROL REGISTER - 0XF71

Bit	R/W	Default	Description
7:0	RW	01	SP2_VSTART [7:0], SPOT2 Vertical Start Register This register determines the lower 8 bits of SPOT2 Vertical start address

SPOT2 CONTROL REGISTER - 0XF72

Bit	R/W	Default	Description
7	N/A	0	SP2 Quad Mode Enable When Enable, the SP2 memory controller will read half of each line data and start a new a new address calculation from second half line as well as half field for the vertical address to prevent whole screen jumping when weak video is presence. This bit should set to one when screen image is set to quad mode.
6	N/A		Reserved
5:4	RW	0	SP2_VSTART [9:8], SPOT2 Horizontal Start Register Upper 2 bits of the SPOT2 Horizontal start register
3:0	RW	0	SP2_VSTART [11:8], SPOT2 Vertical Start Register Upper 4 bits of the SPOT2 Vertical start register

SPOT2 CONTROL REGISTER – 0XF73

Bit	R/W	Default	Description
7:0	RW	00	SP2_SRC_WID [7:0], SPOT2 Down Scale Source Width Register This register determines the source width of the image. The upper 3 bits are in register 0xF6D.

SPOT2 CONTROL REGISTER – 0XF74

Bit	R/W	Default	Description
7:0	RW	00	SP2_SRC_HI [7:0], SPOT2 Down Scale Source Height Register This register determines the source height of the image. The upper 3 bits are in register 0xF6D.

SPOT2 CONTROL REGISTER – 0XF75

Bit	R/W	Default	Description
7:0	RW	00	SP2_DST_WID [7:0], SPOT2 Down Scale Destination Width Register This register determines the source width of the image. The upper 2 bits are in register 0xF6D.

SPOT2 CONTROL REGISTER – 0XF76

Bit	R/W	Default	Description
7:0	RW	00	SP2_DST_HI [7:0], SPOT2 Down Scale Destination Height Register This register determines the source height of the image. The upper 1 bit is in register 0xF6E.

SPOT2 CONTROL REGISTER – 0XF77

Bit	R/W	Default	Description
7:6	RW	0	SP2_TVENC_FSC_MODE, SPOT2 TV FSCSEL This register determines the TV modulation frequency standard select. 00 - NTSC M 01 - PAL B, D, G, H, I 10 - PAL M 11 - PAL N
5	RW	0	SP2_TVENC_SAT_LMT, SPOT2 TV video saturation limit Control the data range of the ITU-R BT 656 output 0 - Not limit 1 - Data range is limited to 1 - 254 range
4:1	N/A	0	Reserved

Bit	R/W	Default	Description
0	RW	0	SP2_TV PAL or NTSC select This register determines the CVBS output Standard. 0: NSTC mode 1: PAL mode.

SPOT2 CONTROL REGISTER - 0XF78

Bit	R/W	Default	Description
7	RW	0	SP2_TVENC_VSPOL, SPOT2 TVENC Vertical sync polarity 0: Active Low 1: Active High
6	RW	0	SP2_TVENC_HSPOL, SPOT2 TV Encoder Horizontal Sync Polarity 0: Active Low 1: Active High
5	RW	0	SP2_TVENC_VSDDET, SPOT1 TV Encoder Vsync Det.
4	RW	0	SP2_TVENC_PED, SPOT2 TV Encoder Pedestal Enable Enable Pedestal for video output 0: 0 IRE for pedestal 1: 7.5 IRE pedestal level
3	RW	0	SP2_TVENC_PDRST, SPOT2 TV Encoder Pedestal Reset Subcarrier Phase Alternation reset every 8 fields in PAL system 0: Constant relationship, reset every 8 fields 1: Free running
2	RW	0	SP2_TVENC_PHALT, SPOT2 TV Encoder Phase Alternation 0: Disable phase alternation for line by line 1: Enable phase alternation for line by line
1	RW	0	SP2_TVENC_F_INV, SPOT2 TV Encoder Field Output Invert This register bit inverts the field output level if set.
0	RW	0	SP2_TVENC_INTERLACE, SPOT2 TVENC Interlace Select This register bit determines the TV Standard in Interlace timing mode. 0 - Progressive 1 - Interlace

SPOT2 CONTROL REGISTER - 0XF79

Bit	R/W	Default	Description
7:6	N/A		Reserved
5:4	RW	0	SP2_TVENC_YC_OS[1:0], SPOT2 TV Encoder Active Pixel Offset delay 00: No Active offset 01: Active pixel offset for 1/4 pixel unit 10: Active pixel offset for 1/2 pixel unit 11: Active pixel offset for 3/4 pixel unit
3:2	RW	0	SP2_TVENC_OSENC[1:0], SPOT2 TV Encoder Field Offset for the first video line 00: Apply same ENC_VDSEL for odd and even field 01: Apply same ENC_VDSEL for odd and odd field 10: Apply TVENC_VSDEL for odd field and TVENC_VSDEL+1 for even field 11: Apply TVENC_VSDEL for odd field and TVENC_VSDEL+2 for even field
1	RW	0	SP2_TVENC_FLDENCP, SPOT2 TV Encoder Field Polarity This Register control the field polarity 0: Even field is high 1: Odd field is high
0	RW	0	SP2_TVENC_FLDDDET, SPOT2 TV Encoder Field Detect

SPOT2 CONTROL REGISTER - 0XF7A

Bit	R/W	Default	Description
7:0	RW	0	SP2_TVENC_HSENC[7:0], SPOT2 TV Encoder Active pixel delay Lower 8 bits of the pixel delay from active video by 1/2 pixel per step

SPOT2 CONTROL REGISTER - 0XF7B

Bit	R/W	Default	Description
7:2	N/A	0	SP2_Rotate_Time_Offset
1:0	RW	0	SP2_TVENC_HSENC[9:8], SPOT2 TV Encoder Active pixel delay Upper 2 bits of the pixel delay from active video by 1/2 pixel per step

SPOT2 CONTROL REGISTER - 0XF7C

Bit	R/W	Default	Description
7:6	N/A	1	SP2_CVBS_SEL 11 : SP2 CVBS output is coming from SP4 10 : SP2 CVBS output is coming from SP3 01 : SP2 CVBS output is coming from SP2 00 : SP2 CVBS output is coming from SP1
5:0	RW	0	SP2_TVENC_VSENC, SPOT2 TV Encoder Active line delay 6 bits of the line delay from active video by line per step

SPOT2 CONTROL REGISTER - 0XF7D

Bit	R/W	Default	Description
7:5	N/A		Reserved
4:0	RW	0	SP2_TVENC_LINE_OS, SPOT2 TV Encoder Active line offset 5 bits of the line offset

SPOT2 CONTROL REGISTER - 0XF7E

Bit	R/W	Default	Description
7:6	N/A	0	[7;6] SP2_FLD_SW_MODE [7] Field Switching Mode enable [6] Field Switch Mode image height is 240 lines Enable
5:0	RW	0	SP2_TVENC_PIXEL_OS, SPOT2 TV Encoder Active Pixel offset 6 bits of the pixel offset

SPOT2 CONTROL REGISTER - 0XF7F

Bit	R/W	Default	Description
7	N/A		Reserved
6	RW	0	SP2_TVENC_C_OFF_D, SPOT2 TV Encoder C Off Set the Color Off if set
5:4	RW	0	SP2_TVENC_CBW_D, SPOT2 TV Encoder CbCr delay 2 bits of the CbCr delay
3:2	RW	0	SP2_TVENC_YBW_D, SPOT2 TV Encoder Luma delay 2 bits of the Luminous delay
1:0	RW	0	SP2_TVENC_FLD_OS, SPOT2 TV Encoder Active Field offset 2 bits of the field offset

SPOT2 CONTROL REGISTER - 0XF80

Bit	R/W	Default	Description
7	RW	0	SP2_TVENC_TST_FSC_FREE, SPOT2 TV Encoder Sub-Carrier is set to free run
6	RW	0	SP2_TVENC_T_CCIR_TIM, SPOT2 TV Encoder CCOR Timing 2 bits of the CbCr delay
5	RW	0	SP2_TVENC_T_656_STD, SPOT2 TV Encoder 656 Standard 2 bits of the Luminous delay
4:0	RW	0	SP2_TVENC_VIS_LINE_OS, SPOT2 TV Encoder line offset 5 bits Line offset

SPOT2 CONTROL REGISTER - 0XF81

Bit	R/W	Default	Description
7:5	RW		Reserved
4	RW	0	SP2_OSD_TITLE_EN Display title enable 1: enable 0: disable
3	RW	0	SP2_OSD_TIME_EN Display time and date enable 1: enable 0: disable
2	RW	0	SP2_OSD_CHPIC_EN Display picture for each channel 1: enable 0: disable
1	RW	0	SP2_OSD_CHNUM_EN Display channel number for each channel 1: enable 0: disable
0	RW	0	SP2_OSD_EN All OSD information enable or disable. If set to 1, each information is enabled by bit [4:1]. If set to 0, all OSD is disabled. 1: enable 0: disable

SPOT2 CONTROL REGISTER - 0XF82

Bit	R/W	Default	Description
7:6	RW	0	Reserved
5	RW	0	SP2_OSD_CHPIC_BLINK If set to 1, picture for each channel blink in picture index 2 and 3. Picture 0 and 1 will not blink 1: enable 0: disable
4	RW	0	SP2_OSD_CHPIC_TRANS If set to 1, picture in color index "00" will be transparent 1: enable 0: disable
3	RW	0	SP2_OSD_TITLE_MIX Display title mix enable bit. If set to 1, title will be 50% blending with video 1: enable 0: disable
2	RW	0	SP2_OSD_TIME_MIX Display time and date mix enable bit. If set to 1, time/date will be 50% blending with video 1: enable 0: disable

Bit	R/W	Default	Description
1	RW	0	SP2_OSD_CHPIC_MIX Display picture mix enable bit. If set to 1, picture will be 50% blending with video 1: enable 0: disable
0	RW	0	SP2_OSD_CHNUM_MIX Display channel number information mix enable bit. If set to 1, channel information will be 50% blending with video 1: enable 0: disable

SPOT2 OSD FONT SIZE REGISTER – 0XF83

Bit	R/W	Default	Description
7:6	RW	0x1	SP2_OSD_CHPIC_POS Channel picture corner position. 00: left top 01: right top 10: left bottom 11: right bottom
5:4	RW	0	SP2_OSD_CHNUM_POS Channel number corner position. 00: left top 01: right top 10: left bottom 11: right bottom
3:2	RW	0x3	SP2_OSD_FONT_VSIZE Font vertical size for display. There are four choices. 00: 8 01: 10 10: 16, scale up from 8 11: 20, scale up from 10
1:0	RW	0x3	SP2_OSD_FONT_HSIZE Font horizontal size for display. There are four choices. 00: 6 01: 8 10: 12, scale up from 6 11: 16, scale up from 8

SPOT2 OSD TIME AND DATE HORIZONTAL POSITION LOW BYTE REGISTER – 0XF84

Bit	R/W	Default	Description
7:0	RW	0	SP2_OSD_TIME_HPOS[7:0] Time and Date information horizontal position. It is one pixel unit.

SPOT2 OSD TIME AND DATE HORIZONTAL POSITION HIGH BYTE REGISTER – 0XF85

Bit	R/W	Default	Description
2:0	RW	0	SP2_OSD_TIME_HPOS[10:8] Time and Date information horizontal position. It is one pixel unit.

SPOT2 OSD TIME AND DATE VERTICAL POSITION LOW BYTE REGISTER – 0XF86

Bit	R/W	Default	Description
7:0	RW	0	SP2_OSD_TIME_VPOS[7:0] Time and Date information vertical position. It is one pixel unit.

SPOT2 OSD TIME AND DATE VERTICAL POSITION HIGH BYTE REGISTER – 0XF87

Bit	R/W	Default	Description
2:0	RW	0	SP2_OSD_TIME_VPOS[10:8] Time and Date information vertical position. It is one pixel unit.

SPOT2 OSD TITLE HORIZONTAL POSITION LOW BYTE REGISTER – 0XF88

Bit	R/W	Default	Description
7:0	RW	0	SP2_OSD_TITLE_HPOS[7:0] Title information horizontal position. It is one pixel unit.

SPOT2 OSD TITLE HORIZONTAL POSITION HIGH BYTE REGISTER – 0XF89

Bit	R/W	Default	Description
7:3	RW	0	Vertical Start Address offset [12:8] in 256 or 512 Mb memory configuration
2:0	RW	0	SP2_OSD_TITLE_HPOS[10:8] Title information horizontal position. It is one pixel unit.

SPOT2 OSD TITLE VERTICAL POSITION LOW BYTE REGISTER – 0XF8A

Bit	R/W	Default	Description
7:0	RW	0	SP2_OSD_TITLE_VPOS[7:0] Title information vertical position. It is one pixel unit.

SPOT2 OSD TITLE HORIZONTAL POSITION HIGH BYTE REGISTER – 0XF8B

Bit	R/W	Default	Description
2:0	RW	0	SP2_OSD_TITLE_VPOS[10:8] Title information vertical position. It is one pixel unit.

SPOT2 OSD FONT AND PICTURE RAM ADDRESS LOW BYTE REGISTER – 0XF8C

Bit	R/W	Default	Description
7:0	RW	0	SP2_OSD_FRAM_ADDR[7:0] Font and Picture SRAM address. When host write data to this SRAM, address is written first and then data. SRAM size is 1152x16. Font size is 640x16, Picture size is 512x16.

SPOT2 OSD FONT AND PICTURE RAM ADDRESS HIGH BYTE REGISTER – 0XF8D

Bit	R/W	Default	Description
2:0	RW	0	SP2_OSD_FRAM_ADDR[10:8] Font and Picture SRAM address. When host write data to this SRAM, address is written first and then data. SRAM size is 1152x16. Font size is 640x16, Picture size is 512x16.

SPOT2 OSD FONT AND PICTURE RAM DATA LOW BYTE REGISTER – 0XF8E

Bit	R/W	Default	Description
7:0	RW	0	SP2_OSD_FRAM_DATA[7:0] Font and Picture SRAM address. When host write data to this SRAM, address is written first and then data. SRAM size is 1152x16. Font size is 640x16, Picture size is 512x16.

SPOT2 OSD FONT AND PICTURE RAM DATA HIGH BYTE REGISTER – 0XF8F

Bit	R/W	Default	Description
7:0	RW	0	SP2_OSD_FRAM_DATA[15:8] Font and Picture SRAM address. When host write data to this SRAM, address is written first and then data. SRAM size is 1152x16. Font size is 640x16, Picture size is 512x16.

SPOT3 CONTROL REGISTER – 0XF90

Bit	R/W	Default	Description
7:0	RW	0	SP3_HTT [7:0], SPOT3 Horizontal Total Register Lower 8 bits of the SP3_HTT

SPOT3 CONTROL REGISTER – 0XF91

Bit	R/W	Default	Description
7:5	N/A		Reserved
4:0	RW	0	SP3_HTT [12:8], SPOT3 Horizontal Total Register Upper 5 bits of the SP3_HTT

SPOT3 CONTROL REGISTER – 0XF92

Bit	R/W	Default	Description
7:0	RW	0	SP3_HDE [7:0], SPOT3 Horizontal Display Enable Register Lower 8 bits of the SP3_HDE register

SPOT3 CONTROL REGISTER – 0XF93

Bit	R/W	Default	Description
7:4	N/A		Reserved
3:0	RW	0	SP3_HDE [11:8], SPOT3 Horizontal Display Enable Register Upper 4 bits of the SP3_HDE

SPOT3 CONTROL REGISTER – 0XF94

Bit	R/W	Default	Description
7:0	RW	0	SP3_VDE [7:0], SPOT3 Vertical Display Enable Register Lower 8 bits of the SP3_VDE register

SPOT3 CONTROL REGISTER – 0XF95

Bit	R/W	Default	Description
7:4	N/A		BND_CH_EN[10:8] Border Channel Enable
3	N/A		Reserved
2:0	RW	0	SP3_VDE [11:8], SPOT3 Vertical Display Enable Register Upper 3 bits of the Vertical Display Enable Register

SPOT3 CONTROL REGISTER – 0XF96

Bit	R/W	Default	Description
7:0	RW	0	SP3_PHSYNC [7:0], SPOT3 Horizontal Position Sync Register Lower 8 bits of the SP3_PHSYNC The register value determine when the horizontal sync start when the horizontal display counter reach to the sum of SP3_HDE and SP3_PHSYNC

SPOT3 CONTROL REGISTER – 0XF97

Bit	R/W	Default	Description
7:4	N/A		Reserved
3:2	RW	0	SP3 FRSC Control 11: bank_sel equals bank_selB 10: bank_sel equals {vblank, fld} 01: bank_sel equals {bank_selA[1], fld} 00: bank_sel equals bank_selA 11: wr_page equals wr_pageB 10: wr_page equals {~vblank, 0} 01: wr_page equals {!bank_selA[1], fld} 00: wr_page equals wr_pageA
1	N/A		Reserved
0	RW	0	SP3_PHSYNC [8], SPOT3 Horizontal Position Sync Register Upper 1 bit of the SP3_PHSYNC

SPOT3 CONTROL REGISTER – 0XF98

Bit	R/W	Default	Description
7:0	RW	0	SP3_PVSYNC [7:0], SPOT3 Vertical Position Sync Register Lower 8 bits of the SP3_PVSYNC The register value determine when the horizontal sync start when the horizontal display counter reach to the sum of SP3_VDE and SP3_PVSYNC

SPOT3 CONTROL REGISTER – 0XF99

Bit	R/W	Default	Description
7:0	RW	0	SP3_VTT[7:0]

SPOT3 CONTROL REGISTER – 0XF9A

Bit	R/W	Default	Description
7	RW	0	[7] SP3_Half_D1 Select
6:3	RW	0	Reserve
2:0	RW	0	[2:0] SP3_VTT[10:8]

SPOT3 CONTROL REGISTER – 0XF9B

Bit	R/W	Default	Description
7:6	RW	0	SP3_VBLANK_SEL
5	RW	0	SP3_COLOR BAR ENA
4	RW	0	SP3_SWITCH_EN 0: Background enable 1: Background display disable

Bit	R/W	Default	Description
3:2	RW	0	SP3_FLD select 11: use bank0 from the FRSC as the field 10: use bank0 from the FRSC inverse as the filed 0x: use HVCNT generated field
1:0	RW	0	SPOT_POWER_DOWN_EN [1] SP2 PD enable when 0 [0] SP1 PD enable when 0

SPOT3 CONTROL REGISTER – 0XF9C

Bit	R/W	Default	Description
7:4	RW	0	REC, NETWORK port use SP1 as the display [7] = 1, select Network port to display on SP1 = 0, [6:4] selects REC PORT 1 - 8 display on SP1 [6:4] = 0, selects REC PORT1, [6:4] = 1, selects REC PORT2,
3:0	RW	0	REC, NETWORK port use SP2 as the display [3] = 1, select Network port to display on SP2 = 0, [2:0] selects REC PORT 1 - 8 display on SP2 [2:0] = 0, selects REC PORT1, [2:0] = 1, selects REC PORT2,

SPOT3 CONTROL REGISTER – 0XF9D

Bit	R/W	Default	Description
7:0	RW	0	SP3_DNS Upper Bits [7:6] SP3 Destination Width upper bit [9:8] [5:3] SP3 Source Height upper bit [10:8] [2:0] SP3 Source Width upper bit [10:8]

SPOT3 CONTROL REGISTER – 0XF9E

Bit	R/W	Default	Description
7	RW	0	SP3 REC or Network port Enable Enable the REC or Network port to use SP3 as display
6:4	RW	0	SP3 color bar select
3:1	RW	0	SP3_Firsrt_line_control
0	RW	0	SP3 Destination Height upper bit [8]

SPOT3 CONTROL REGISTER – 0XF9F

Bit	R/W	Default	Description
7	R/W	1	SP3 Field Mode Select 1: Field mode 0: Frame mode
6	RW	0	SP3_2ND_MEM Enable

Bit	R/W	Default	Description
5	RW	0	SP3_FRMCNT_EN SPOT3 Frame Count Enable
4	RW	0	SP3_ENA SPOT3 Enable
3:2	RW	0	SP3_ROT Rotation Enable
1	RW	0	SP3_VSPOL SPOT3 Vertical Polarity Control
0	RW	0	SP3_HSPOL SPOT3 Horizontal Polarity Control

SPOT3 CONTROL REGISTER - 0XFA0

Bit	R/W	Default	Description
7:0	RW	00	SP3_HSTART [7:0], SPOT3 Horizontal Start Register This register determines the lower 8 bits of SPOT3 Horizontal start address

SPOT3 CONTROL REGISTER - 0XFA1

Bit	R/W	Default	Description
7:0	RW	01	SP3_VSTART [7:0], SPOT3 Vertical Start Register This register determines the lower 8 bits of SPOT3 Vertical start address

SPOT3 CONTROL REGISTER - 0XFA2

Bit	R/W	Default	Description
7	N/A		SP3 Quad Mode Enable When Enable, the SP3 memory controller will read half of each line data and start a new a new address calculation from second half line as well as half field for the vertical address to prevent whole screen jumping when weak video is presence. This bit should set to one when screen image is set to quad mode.
6	N/A		Reserve
5:4	RW	0	SP3_VSTART [9:8], SPOT3 Horizontal Start Register Upper 2 bits of the SPOT3 Horizontal start register
3:0	N/A		SP3_VSTART [11:8], SPOT3 Vertical Start Register Upper 4 bits of the SPOT3 Vertical start register

SPOT3 CONTROL REGISTER - 0XFA3

Bit	R/W	Default	Description
7:0	RW	00	SP3_SRC_WID [7:0], SPOT3 Down Scale Source Width Register This register determines the source width of the image. The upper 3 bits are in register 0xF9D.

SPOT3 CONTROL REGISTER – 0XFA4

Bit	R/W	Default	Description
7:0	RW	00	SP3_SRC_HI [7:0], SPOT3 Down Scale source height Register This register determines the source height of the image. The upper 3 bits are in register 0xF9D.

SPOT3 CONTROL REGISTER – 0XFA5

Bit	R/W	Default	Description
7:0	RW	00	SP3_DST_WID [7:0], SPOT3 Down Scale Destination Width Register This register determines the destination width of the image. The upper 2 bits are in register 0xF6D.

SPOT3 CONTROL REGISTER – 0XFA6

Bit	R/W	Default	Description
7:0	RW	00	SP3_DST_HI [7:0], SPOT3 Down Scale Destination height Register This register determines the destination height of the image. The upper 1 bits are in register 0xF9E.

SPOT3 CONTROL REGISTER – 0XFA7

Bit	R/W	Default	Description
7:6	RW	0	SP3_TVENC_FSC_MODE, SPOT3 TV FSCSEL This register determines the TV modulation frequency standard select. 00 - NTSC M 01 - PAL B, D, G, H, I 10 - PAL M 11 - PAL N
5	RW	0	SP3_TVENC_SAT_LMT, SPOT3 TV video saturation limit Control the data range of the ITU-R BT 656 output 0 - Not limit 1 - Data range is limited to 1 - 254 range
4:1	N/A	0	Reserved
0	RW	0	SP3_TVENC_PALNT, SPOT3 TV PAL or NTSC select This register determines the CVBS output Standard. 0: NSTC mode 1: PAL mode.

SPOT3 CONTROL REGISTER – 0XFA8

Bit	R/W	Default	Description
-----	-----	---------	-------------

Bit	R/W	Default	Description
7	RW	0	SP3_TVENC_VSPOL, SPOT3 TVENC Vertical sync polarity 0: Active Low 1: Active High
6	RW	0	SP3_TVENC_HSPOL, SPOT3 TV Encoder Horizontal Sync Polarity 0: Active Low 1: Active High
5	RW	0	SP3_TVENC_VSDDET, SPOT3 TV Encoder Vsync Det.
4	RW	0	SP3_TVENC_PED, SPOT3 TV Encoder Pedestal Enable Enable Pedestal for video output 0: 0 IRE for pedestal 1: 7.5 IRE pedestal level
3	RW	0	SP3_TVENC_PDRST, SPOT3 TV Encoder Pedestal Reset Subcarrier Phase Alternation reset every 8 fields in PAL system 0: Constant relationship, reset every 8 fields 1: Free running
2	RW	0	SP3_TVENC_PHALT, SPOT3 TV Encoder Phase Alternation 0: Disable phase alternation for line by line 1: Enable phase alternation for line by line
1	RW	0	SP3_TVENC_F_INV, SPOT3 TV Encoder Field Output Invert This register bit inverts the field output level if set.
0	RW	0	SP3_TVENC_INTERLACE, SPOT3 TVENC Interlace Select This register bit determines the TV Standard in Interlace timing mode. 0 - Progressive 1 - Interlace

SPOT3 CONTROL REGISTER – 0XFA9

Bit	R/W	Default	Description
7:6	N/A		Reserved
5:4	RW	0	SP3_TVENC_YC_OS[1:0], SPOT3 TV Encoder Active Pixel Offset delay 00: No Active offset 01: Active pixel offset for 1/4 pixel unit 10: Active pixel offset for 1/2 pixel unit 11: Active pixel offset for 3/4 pixel unit
3:2	RW	0	SP3_TVENC_OSENC[1:0], SPOT3 TV Encoder Field Offset for the first video line 00: Apply same ENC_VDSEL for odd and even field 01: Apply same ENC_VDSEL for odd and odd field 10: Apply TVENC_VSDEL for odd field and TVENC_VSDEL+1 for even field 11: Apply TVENC_VSDEL for odd field and TVENC_VSDEL+2 for even field

1	RW	0	SP3_TVENC_FLDENCP, SPOT3 TV Encoder Field Polarity This Register control the field polarity 0: Even field is high 1: Odd field is high
0	RW	0	SP3_TVENC_FLDDDET, SPOT3 TV Encoder Field Detect

SPOT3 CONTROL REGISTER – 0XFAA

Bit	R/W	Default	Description
7:0	RW	0	SP3_TVENC_HSENC[7:0], SPOT3 TV Encoder Active pixel delay Lower 8 bits of the pixel delay from active video by ½ pixel per step

SPOT3 CONTROL REGISTER – 0XFAB

Bit	R/W	Default	Description
7:2	N/A	0	SP2_Rotate_Time_Offset
1:0	RW	0	SP3_TVENC_HSENC[9:8], SPOT3 TV Encoder Active pixel delay Upper 2 bits of the pixel delay from active video by ½ pixel per step

SPOT3 CONTROL REGISTER – 0XFAC

Bit	R/W	Default	Description
7:6	N/A	10	SP3_CVBS_SEL 11 : SP3 CVBS output is coming from SP4 10 : SP3 CVBS output is coming from SP3 01 : SP3 CVBS output is coming from SP2 00 : SP3 CVBS output is coming from SP1
5:0	RW	0	SP3_TVENC_VSENC, SPOT3 TV Encoder Active line delay 6 bits of the line delay from active video by line per step

SPOT3 CONTROL REGISTER – 0XFAD

Bit	R/W	Default	Description
7:5	N/A		Reserved
4:0	RW	0	SP3_TVENC_LINE_OS, SPOT3 TV Encoder Active line offset 5 bits of the line offset

SPOT3 CONTROL REGISTER – 0XFAE

Bit	R/W	Default	Description
7:6	N/A	0	[7;6] SP3_FLD_SW_MODE [7] Field Switching Mode enable [6] Field Switch Mode image height is 240 lines Enable
5:0	RW	0	SP3_TVENC_PIXEL_OS, SPOT3 TV Encoder Active Pixel offset 6 bits of the pixel offset

SPOT3 CONTROL REGISTER - 0XFAF

Bit	R/W	Default	Description
7	N/A		Reserved
6	RW	0	SP3_TVENC_C_OFF_D, SPOT3 TV Encoder C Off Set the Color Off if set
5:4	RW	0	SP3_TVENC_CBW_D, SPOT3 TV Encoder CbCr delay 2 bits of the CbCr delay
3:2	RW	0	SP3_TVENC_YBW_D, SPOT3 TV Encoder Luma delay 2 bits of the Luminous delay
1:0	RW	0	SP3_TVENC_FLD_OS, SPOT3 TV Encoder Active Field offset 2 bits of the field offset

SPOT3 CONTROL REGISTER - 0XFB0

Bit	R/W	Default	Description
7	RW	0	SP3_TVENC_TST_FSC_FREE, SPOT3 TV Encoder Sub-Carrier is set to free run
6	RW	0	SP3_TVENC_T_CCIR_TIM, SPOT3 TV Encoder CCOR Timing 2 bits of the CbCr delay
5	RW	0	SP3_TVENC_T_656_STD, SPOT3 TV Encoder 656 Standard 2 bits of the Luminous delay
4:0	RW	0	SP3_TVENC_VIS_LINE_OS, SPOT2 TV Encoder line offset 5 bits Line offset

SPOT3 CONTROL REGISTER - 0XFB1

Bit	R/W	Default	Description
7:5	RW	0	Reserved
4	RW	0	SP3_OSD_TITLE_EN Display title enable 1: enable 0: disable
3	RW	0	SP3_OSD_TIME_EN Display time and date enable 1: enable 0: disable
2	RW	0	SP3_OSD_CHPIC_EN Display picture for each channel 1: enable 0: disable

Bit	R/W	Default	Description
1	RW	0	SP3_OSD_CHNUM_EN Display channel number for each channel 1: enable 0: disable
0	RW	0	SP3_OSD_EN All OSD information enable or disable. If set to 1, each information is enabled by bit [4:1]. If set to 0, all OSD is disabled. 1: enable 0: disable

SPOT3 CONTROL REGISTER – 0XFB2

Bit	R/W	Default	Description
7:6	RW	0	Reserved
5	RW	0	SP3_OSD_CHPIC_BLINK If set to 1, picture for each channel blink in picture index 2 and 3. Picture 0 and 1 will not blink 1: enable 0: disable
4	RW	0	SP3_OSD_CHPIC_TRANS If set to 1, picture in color index "00" will be transparent 1: enable 0: disable
3	RW	0	SP3_OSD_TITLE_MIX Display title mix enable bit. If set to 1, title will be 50% blending with video 1: enable 0: disable
2	RW	0	SP3_OSD_TIME_MIX Display time and date mix enable bit. If set to 1, time/date will be 50% blending with video 1: enable 0: disable
1	RW	0	SP3_OSD_CHPIC_MIX Display picture mix enable bit. If set to 1, picture will be 50% blending with video 1: enable 0: disable
0	RW	0	SP3_OSD_CHNUM_MIX Display channel number information mix enable bit. If set to 1, channel information will be 50% blending with video 1: enable 0: disable

SPOT3 OSD FONT SIZE REGISTER – 0XFB3

Bit	R/W	Default	Description
7:6	RW	0x1	SP3_OSD_CHPIC_POS Channel picture corner position. 00: left top 01: right top 10: left bottom 11: right bottom
5:4	RW	0	SP3_OSD_CHNUM_POS Channel number corner position. 00: left top 01: right top 10: left bottom 11: right bottom
3:2	RW	0x3	SP3_OSD_FONT_VSIZE Font vertical size for display. There are four choices. 00: 8 01: 10 10: 16, scale up from 8 11: 20, scale up from 10
1:0	RW	0x3	SP3_OSD_FONT_HSIZE Font horizontal size for display. There are four choices. 00: 6 01: 8 10: 12, scale up from 6 11: 16, scale up from 8

SPOT3 OSD TIME AND DATE HORIZONTAL POSITION LOW BYTE REGISTER – 0XFB4

Bit	R/W	Default	Description
7:0	RW	0	SP3_OSD_TIME_HPOS[7:0] Time and Date information horizontal position. It is one pixel unit.

SPOT3 OSD TIME AND DATE HORIZONTAL POSITION HIGH BYTE REGISTER – 0XFB5

Bit	R/W	Default	Description
2:0	RW	0	SP3_OSD_TIME_HPOS[10:8] Time and Date information horizontal position. It is one pixel unit.

SPOT3 OSD TIME AND DATE VERTICAL POSITION LOW BYTE REGISTER – 0XFB6

Bit	R/W	Default	Description
7:0	RW	0	SP3_OSD_TIME_VPOS[7:0] Time and Date information vertical position. It is one pixel unit.

SPOT3 OSD TIME AND DATE VERTICAL POSITION HIGH BYTE REGISTER – 0XFB7

Bit	R/W	Default	Description
2:0	RW	0	SP3_OSD_TIME_VPOS[10:8] Time and Date information vertical position. It is one pixel unit.

SPOT3 OSD TITLE HORIZONTAL POSITION LOW BYTE REGISTER – 0XFB8

Bit	R/W	Default	Description
7:0	RW	0	SP3_OSD_TITLE_HPOS[7:0] Title information horizontal position. It is one pixel unit.

SPOT3 OSD TITLE HORIZONTAL POSITION HIGH BYTE REGISTER – 0XFB9

Bit	R/W	Default	Description
2:0	RW	0	SP3_OSD_TITLE_HPOS[10:8] Title information horizontal position. It is one pixel unit.

SPOT3 OSD TITLE VERTICAL POSITION LOW BYTE REGISTER – 0XFBA

Bit	R/W	Default	Description
7:0	RW	0	SP3_OSD_TITLE_VPOS[7:0] Title information vertical position. It is one pixel unit.

SPOT3 OSD TITLE HORIZONTAL POSITION HIGH BYTE REGISTER – 0XFBB

Bit	R/W	Default	Description
2:0	RW	0	SP3_OSD_TITLE_VPOS[10:8] Title information vertical position. It is one pixel unit.

SPOT3 OSD FONT AND PICTURE RAM ADDRESS LOW BYTE REGISTER – 0XFBC

Bit	R/W	Default	Description
7:0	RW	0	SP3_OSD_FRAM_ADDR[7:0] Font and Picture SRAM address. When host write data to this SRAM, address is written first and then data. SRAM size is 1152x16. Font size is 640x16, Picture size is 512x16.

SPOT3 OSD FONT AND PICTURE RAM ADDRESS HIGH BYTE REGISTER – 0XFBD

Bit	R/W	Default	Description
2:0	RW	0	SP3_OSD_FRAM_ADDR[10:8] Font and Picture SRAM address. When host write data to this SRAM, address is written first and then data. SRAM size is 1152x16. Font size is 640x16, Picture size is 512x16.

SPOT3 OSD FONT AND PICTURE RAM DATA LOW BYTE REGISTER – 0XFBE

Bit	R/W	Default	Description
7:0	RW	0	SP3_OSD_FRAM_DATA[7:0] Font and Picture SRAM address. When host write data to this SRAM, address is written first and then data. SRAM size is 1152x16. Font size is 640x16, Picture size is 512x16.

SPOT3 OSD FONT AND PICTURE RAM DATA HIGH BYTE REGISTER – 0XFBF

Bit	R/W	Default	Description
7:0	RW	0	SP3_OSD_FRAM_DATA[15:8] Font and Picture SRAM address. When host write data to this SRAM, address is written first and then data. SRAM size is 1152x16. Font size is 640x16, Picture size is 512x16.

SPOT4 CONTROL REGISTER – 0XFC0

Bit	R/W	Default	Description
7:0	RW	0	SP4_HTT [7:0], SPOT4 Horizontal Total Register Lower 8 bits of the SP4_HTT

SPOT4 CONTROL REGISTER – 0XFC1

Bit	R/W	Default	Description
7:5	N/A		Reserved
4:0	RW	0	SP4_HTT [12:8], SPOT4 Horizontal Total Register Upper 5 bits of the SP4_HTT

SPOT4 CONTROL REGISTER – 0XFC2

Bit	R/W	Default	Description
7:0	RW	0	SP4_HDE [7:0], SPOT4 Horizontal Display Enable Register Lower 8 bits of the HDE register

SPOT4 CONTROL REGISTER – 0XFC3

Bit	R/W	Default	Description
7:4	N/A		Reserved
3:0	RW	0	SP4_HDE [11:8], SPOT4 Horizontal Display Enable Register Upper 4 bits of the SP4_HDE

SPOT4 CONTROL REGISTER – 0XFC4

Bit	R/W	Default	Description
7:0	RW	0	SP4_VDE [7:0], SPOT4 Vertical Display Enable Register Lower 8 bits of the VDE register

SPOT4 CONTROL REGISTER – 0XFC5

Bit	R/W	Default	Description
7:4	N/A		BND_CH_EN[15:11] Border Channel Enable
3	N/A		Reserved
2:0	RW	0	SP4_VDE [11:8], SPOT4 Vertical Display Enable Register Upper 3 bits of the Vertical Display Enable Register

SPOT4 CONTROL REGISTER – 0XFC6

Bit	R/W	Default	Description
7:0	RW	0	SP4_PHSYNC [7:0], SPOT4 Horizontal Position Sync Register Lower 8 bits of the SP4_PHSYNC The register value determine when the horizontal sync start when the horizontal display counter reach to the sum of SP4_HDE and SP4_PHSYNC

SPOT4 CONTROL REGISTER – 0XFC7

Bit	R/W	Default	Description
7:4	N/A		Reserved
3:2	RW	0	SP4 FRSC Control 11: bank_sel equals bank_selB 10: bank_sel equals {vblank, fld} 01: bank_sel equals {bank_selA[1], fld} 00: bank_sel equals bank_selA 11: wr_page equals wr_pageB 10: wr_page equals {~vblank, 0} 01: wr_page equals {!bank_selA[1], fld} 00: wr_page equals wr_pageA
1	RW	0	SP4_PHB [8], SPOT4 Horizontal Blank Register Upper 1 bit of the SP4_PHSYNC
0	RW	0	SP4_PHSYNC [8], SPOT4 Horizontal Position Sync Register Upper 1 bit of the SP4_PHSYNC

SPOT4 CONTROL REGISTER – 0XFC8

Bit	R/W	Default	Description
7:0	RW	0	SP4_PVSYNC [7:0], SPOT4 Vertical Position Sync Register Lower 8 bits of the SP4_PVSYNC The register value determine when the horizontal sync start when the horizontal display counter reach to the sum of SP4_VDE and SP4_PVSYNC

SPOT4 CONTROL REGISTER – 0XFC9

Bit	R/W	Default	Description
7:0	RW	0	SP4_VTT [7:0], SPOT4 Vertical Total Register

SPOT4 CONTROL REGISTER – 0XFCA

Bit	R/W	Default	Description
7	RW	0	[7] SP4_Half_D1 Select
6:3	RW	0	Reserve
2:0	RW	0	[2:0] SP4_VTT[10:8]

SPOT4 CONTROL REGISTER – 0XFCB

Bit	R/W	Default	Description
7:6	RW	0	SP4_VBLANK_SEL
5	RW	0	SP4_COLOR BAR ENA
4	RW	0	SP4_SWITCH_EN
3:2	RW	0	SP4_FLD select 11: use bank0 from the FRSC as the field 10: use bank0 from the FRSC inverse as the filed 0x: use HVCNT generated field
1:0	RW	0	SPOT_POWER_DOWN_EN [1] SP4 PD enable when 0 [0] SP3 PD enable when 0

SPOT4 CONTROL REGISTER – 0XFCC

Bit	R/W	Default	Description
7:4	RW	0	REC, NETWORK port use SP3 as the display [7] = 1, select Network port to display on SP3 = 0, [6:4] selects REC PORT 1 - 8 display on SP3 [6:4] = 0, selects REC PORT1, [6:4] = 1, selects REC PORT2, ...
3:0	RW	0	REC, NETWORK port use SP4 as the display [3] = 1, select Network port to display on SP4 = 0, [2:0] selects REC PORT 1 - 8 display on SP4 [2:0] = 0, selects REC PORT1, [2:0] = 1, selects REC PORT2, ...

SPOT4 CONTROL REGISTER – 0XFCD

Bit	R/W	Default	Description
7:0	RW	0	SP4_DNS Upper Bits [7:6] SP4 Destination Width upper bit [9:8] [5:3] SP4 Source Height upper bit [10:8] [2:0] SP4 Source Width upper bit [10:8]

SPOT4 CONTROL REGISTER – 0XFCE

Bit	R/W	Default	Description
7	RW	0	SP4 REC or Network port Enable Enable the REC or Network port to use SP4 as display
6:4	RW	0	SP4 color bar select
3:1	RW	0	SP4_Firsrt_line_control
0	RW	0	SP4 Destination Height upper bit [8]

SPOT4 CONTROL REGISTER – 0XFCF

Bit	R/W	Default	Description
7	R/W	1	SP4 Field Mode Select 1: Field mode 0: Frame mode
6	RW	0	SP4_2 ND _MEM Enable
5	RW	0	SP4_FRMCNT_EN SPOT4 Frame Count Enable
4	RW	0	SP4_ENA SPOT4 Enable
3:2	RW	0	SP4_ROT Rotation Enable
1	RW	0	SP4_VSPOL SPOT4 Vertical Polarity Control
0	RW	0	SP4_HSPOL SPOT4 Horizontal Polarity Control

SPOT4 CONTROL REGISTER – 0XFD0

Bit	R/W	Default	Description
7:0	RW	00	SP4_HSTART [7:0], SPOT4 Horizontal Start Register This register determines the lower 8 bits of SPOT4 Horizontal start address

SPOT4 CONTROL REGISTER – 0XFD1

Bit	R/W	Default	Description
7:0	RW	01	SP4_VSTART [7:0], SPOT4 Vertical Start Register This register determines the lower 8 bits of SPOT4 Vertical start address

SPOT4 CONTROL REGISTER – 0XFD2

Bit	R/W	Default	Description
7	N/A		<p>SP4 Quad Mode Enable</p> <p>When Enable, the SP4 memory controller will read half of each line data and start a new a new address calculation from second half line as well as half field for the vertical address to prevent whole screen jumping when weak video is presence.</p> <p>This bit should set to one when screen image is set to quad mode.</p>
6	N/A		Reserved
5:4	RW	0	<p>SP4_VSTART [9:8], SPOT4 Horizontal Start Register</p> <p>Upper 2 bits of the SPOT4 Horizontal start register in 4 pixels per unit</p>
3:0	RW	0	<p>SP4_VSTART [11:8], SPOT4 Vertical Start Register</p> <p>Upper 4 bits of the SPOT4 Vertical start register in line per unit</p>

SPOT4 CONTROL REGISTER – 0XFD3

Bit	R/W	Default	Description
7:0	RW	00	<p>SP4_SRC_WID [7:0], SPOT4 Down Scale source width Register</p> <p>This register determines the source width of the image. The upper 3 bits are in register 0xFCF.</p>

SPOT4 CONTROL REGISTER – 0XFD4

Bit	R/W	Default	Description
7:0	RW	00	<p>SP4_SRC_HI [7:0], SPOT4 Down Scale source height Register</p> <p>This register determines the source height of the image. The upper 3 bits are in register 0xFCF.</p>

SPOT4 CONTROL REGISTER – 0XFD5

Bit	R/W	Default	Description
7:0	RW	00	<p>SP4_DST_WID [7:0], SPOT4 Down Scale Destination width Register</p> <p>This register determines the destination width of the image. The upper 2 bits are in register 0xFCF.</p>

SPOT4 CONTROL REGISTER – 0XFD6

Bit	R/W	Default	Description
7:0	RW	00	<p>SP4_DST_HI [7:0], SPOT4 Down Scale Destination height Register</p> <p>This register determines the D height of the image. The upper 1 bit is in register 0xFCE.</p>

SPOT4 CONTROL REGISTER – 0XFD7

Bit	R/W	Default	Description
7:6	RW	0	SP4_TVENC_FSC_MODE, SPOT4 TV FSCSEL This register determines the TV modulation frequency standard select. 00 - NTSC M 01 - PAL B, D, G, H, I 10 - PAL M 11 - PAL N
5	RW	0	SP4_TVENC_SAT_LMT, SPOT4 TV video saturation limit Control the data range of the ITU-R BT 656 output 0 - Not limit 1 - Data range is limited to 1 - 254 range
4:1	N/A	0	Reserved
0	RW	0	SP4_TVENC_PALNT, SPOT4 TV PAL or NTSC select This register determines the CVBS output Standard. 0: NSTC mode 1: PAL mode.

SPOT4 CONTROL REGISTER – 0XFD8

Bit	R/W	Default	Description
7	RW	0	SP4_TVENC_VSPOL, SPOT4 TVENC Vertical sync polarity 0: Active Low 1: Active High
6	RW	0	SP4_TVENC_HSPOL, SPOT4 TV Encoder Horizontal Sync Polarity 0: Active Low 1: Active High
5	RW	0	SP4_TVENC_VSDET, SPOT4 TV Encoder Vsync Det.
4	RW	0	SP4_TVENC_PED, SPOT4 TV Encoder Pedestal Enable Enable Pedestal for video output 0: 0 IRE for pedestal 1: 7.5 IRE pedestal level
3	RW	0	SP4_TVENC_PDRST, SPOT4 TV Encoder Pedestal Reset Subcarrier Phase Alternation reset every 8 fields in PAL system 0: Constant relationship, reset every 8 fields 1: Free running
2	RW	0	SP4_TVENC_PHALT, SPOT4 TV Encoder Phase Alternation 0: Disable phase alternation for line by line 1: Enable phase alternation for line by line

Bit	R/W	Default	Description
1	RW	0	SP4_TVENC_F_INV, SPOT4 TV Encoder Field Output Invert This register bit inverts the field output level if set.
0	RW	0	SP4_TVENC_INTERLACE, SPOT4 TVENC Interlace Select This register bit determines the TV Standard in Interlace timing mode. 0 - Progressive 1 - Interlace

SPOT4 CONTROL REGISTER - 0XFD9

Bit	R/W	Default	Description
7:6	N/A		Reserved
5:4	RW	0	SP4_TVENC_YC_OS[1:0], SPOT4 TV Encoder Active Pixel Offset delay 00: No Active offset 01: Active pixel offset for 1/4 pixel unit 10: Active pixel offset for 1/2 pixel unit 11: Active pixel offset for 3/4 pixel unit
3:2	RW	0	SP4_TVENC_OSENC[1:0], SPOT4 TV Encoder Field Offset for the first video line 00: Apply same ENC_VDSEL for odd and even field 01: Apply same ENC_VDSEL for odd and odd field 10: Apply TVENC_VSDEL for odd field and TVENC_VSDEL+1 for even field 11: Apply TVENC_VSDEL for odd field and TVENC_VSDEL+2 for even field
1	RW	0	SP4_TVENC_FLDCNP, SPOT4 TV Encoder Field Polarity This Register control the field polarity 0: Even field is high 1: Odd field is high
0	RW	0	SP4_TVENC_FLDDDET, SPOT4 TV Encoder Field Detect

SPOT4 CONTROL REGISTER - 0XFDA

Bit	R/W	Default	Description
7:0	RW	0	SP4_TVENC_HSENC[7:0], SPOT4 TV Encoder Active pixel delay Lower 8 bits of the pixel delay from active video by 1/2 pixel per step

SPOT4 CONTROL REGISTER - 0XFDB

Bit	R/W	Default	Description
7:2	N/A	0	SP4_Rotate_Time_Offset
1:0	RW	0	SP4_TVENC_HSENC[9:8], SPOT4 TV Encoder Active pixel delay Upper 2 bits of the pixel delay from active video by 1/2 pixel per step

SPOT4 CONTROL REGISTER – 0XFDC

Bit	R/W	Default	Description
7:6	N/A	11	SP4_CVBS_SEL 11 : SP4 CVBS output is coming from SP4 10 : SP4 CVBS output is coming from SP3 01 : SP4 CVBS output is coming from SP2 00 : SP4 CVBS output is coming from SP1
5:0	RW	0	SP4_TVENC_VSENC, SPOT4 TV Encoder Active line delay 6 bits of the line delay from active video by line per step

SPOT4 CONTROL REGISTER – 0XFDD

Bit	R/W	Default	Description
7:5	N/A		Reserved
4:0	RW	0	SP4_TVENC_LINE_OS, SPOT4 TV Encoder Active line offset 5 bits of the line offset

SPOT4 CONTROL REGISTER – 0XFDE

Bit	R/W	Default	Description
7:6	N/A	0	[7;6] SP4_FLD_SW_MODE [7] Field Switching Mode enable [6] Field Switch Mode image height is 240 lines Enable
5:0	RW	0	SP4_TVENC_PIXEL_OS, SPOT4 TV Encoder Active Pixel offset 6 bits of the pixel offset

SPOT4 CONTROL REGISTER – 0XFDF

Bit	R/W	Default	Description
7	N/A		Reserved
6	RW	0	SP4_TVENC_C_OFF_D, SPOT4 TV Encoder C Off Set the Color Off if set
5:4	RW	0	SP4_TVENC_CBW_D, SPOT4 TV Encoder CbCr delay 2 bits of the CbCr delay
3:2	RW	0	SP4_TVENC_YBW_D, SPOT4 TV Encoder Luma delay 2 bits of the Luminous delay
1:0	RW	0	SP4_TVENC_FLD_OS, SPOT4 TV Encoder Active Field offset 2 bits of the field offset

SPOT4 CONTROL REGISTER – 0XFE0

Bit	R/W	Default	Description
7	RW	0	SP4_TVENC_TST_FSC_FREE, SPOT4 TV Encoder Sub-Carrier is set to free run
6	RW	0	SP4_TVENC_T_CCIR_TIM, SPOT4 TV Encoder CCOR Timing 2 bits of the CbCr delay
5	RW	0	SP4_TVENC_T_656_STD, SPOT4 TV Encoder 656 Standard 2 bits of the Luminous delay
4:0	RW	0	SP4_TVENC_VIS_LINE_OS, SPOT4 TV Encoder line offset 5 bits Line offset

SPOT4 CONTROL REGISTER – 0XFE1

Bit	R/W	Default	Description
7:5	RW		Reserved
4	RW	0	SP4_OSD_TITLE_EN Display title enable 1: enable 0: disable
3	RW	0	SP4_OSD_TIME_EN Display time and date enable 1: enable 0: disable
2	RW	0	SP4_OSD_CHPIC_EN Display picture for each channel 1: enable 0: disable
1	RW	0	SP4_OSD_CHNUM_EN Display channel number for each channel 1: enable 0: disable
0	RW	0	SP4_OSD_EN All OSD information enable or disable. If set to 1, each information is enabled by bit [4:1]. If set to 0, all OSD is disabled. 1: enable 0: disable

SPOT4 CONTROL REGISTER – 0XFE2

Bit	R/W	Default	Description
7:6	RW	0	Reserved
5	RW	0	<p>SP4_OSD_CHPIC_BLINK</p> <p>If set to 1, picture for each channel blink in picture index 2 and 3. Picture 0 and 1 will not blink 1: enable 0: disable</p>
4	RW	0	<p>SP4_OSD_CHPIC_TRANS</p> <p>If set to 1, picture in color index "00" will be transparent 1: enable 0: disable</p>
3	RW	0	<p>SP4_OSD_TITLE_MIX</p> <p>Display title mix enable bit. If set to 1, title will be 50% blending with video 1: enable 0: disable</p>
2	RW	0	<p>SP4_OSD_TIME_MIX</p> <p>Display time and date mix enable bit. If set to 1, time/date will be 50% blending with video 1: enable 0: disable</p>
1	RW	0	<p>SP4_OSD_CHPIC_MIX</p> <p>Display picture mix enable bit. If set to 1, picture will be 50% blending with video 1: enable 0: disable</p>
0	RW	0	<p>SP4_OSD_CHNUM_MIX</p> <p>Display channel number information mix enable bit. If set to 1, channel information will be 50% blending with video 1: enable 0: disable</p>

SPOT4 OSD FONT SIZE REGISTER – 0XFE3

Bit	R/W	Default	Description
7:6	RW	0x1	SP4_OSD_CHPIC_POS Channel picture corner position. 00: left top 01: right top 10: left bottom 11: right bottom
5:4	RW	0	SP4_OSD_CHNUM_POS Channel number corner position. 00: left top 01: right top 10: left bottom 11: right bottom
3:2	RW	0x3	SP4_OSD_FONT_VSIZE Font vertical size for display. There are four choices. 00: 8 01: 10 10: 16, scale up from 8 11: 20, scale up from 10
1:0	RW	0x3	SP4_OSD_FONT_HSIZE Font horizontal size for display. There are four choices. 00: 6 01: 8 10: 12, scale up from 6 11: 16, scale up from 8

SPOT4 OSD TIME AND DATE HORIZONTAL POSITION LOW BYTE REGISTER – 0XFE4

Bit	R/W	Default	Description
7:0	RW	0	SP4_OSD_TIME_HPOS[7:0] Time and Date information horizontal position. It is one pixel unit.

SPOT4 OSD TIME AND DATE HORIZONTAL POSITION HIGH BYTE REGISTER – 0XFE5

Bit	R/W	Default	Description
2:0	RW	0	SP4_OSD_TIME_HPOS[10:8] Time and Date information horizontal position. It is one pixel unit.

SPOT4 OSD TIME AND DATE VERTICAL POSITION LOW BYTE REGISTER – 0XFE6

Bit	R/W	Default	Description
7:0	RW	0	SP4_OSD_TIME_VPOS[7:0] Time and Date information vertical position. It is one pixel unit.

SPOT4 OSD TIME AND DATE VERTICAL POSITION HIGH BYTE REGISTER – 0XFE7

Bit	R/W	Default	Description
2:0	RW	0	SP4_OSD_TIME_VPOS[10:8] Time and Date information vertical position. It is one pixel unit.

SPOT4 OSD TITLE HORIZONTAL POSITION LOW BYTE REGISTER – 0XFE8

Bit	R/W	Default	Description
7:0	RW	0	SP4_OSD_TITLE_HPOS[7:0] Title information horizontal position. It is one pixel unit.

SPOT4 OSD TITLE HORIZONTAL POSITION HIGH BYTE REGISTER – 0XFE9

Bit	R/W	Default	Description
2:0	RW	0	SP4_OSD_TITLE_HPOS[10:8] Title information horizontal position. It is one pixel unit.

SPOT4 OSD TITLE VERTICAL POSITION LOW BYTE REGISTER – 0XFEA

Bit	R/W	Default	Description
7:0	RW	0	SP4_OSD_TITLE_VPOS[7:0] Title information vertical position. It is one pixel unit.

SPOT4 OSD TITLE HORIZONTAL POSITION HIGH BYTE REGISTER – 0XFEB

Bit	R/W	Default	Description
2:0	RW	0	SP4_OSD_TITLE_VPOS[10:8] Title information vertical position. It is one pixel unit.

SPOT4 OSD FONT AND PICTURE RAM ADDRESS LOW BYTE REGISTER – 0XFEC

Bit	R/W	Default	Description
7:0	RW	0	SP4_OSD_FRAM_ADDR[7:0] Font and Picture SRAM address. When host write data to this SRAM, address is written first and then data. SRAM size is 1152x16. Font size is 640x16, Picture size is 512x16.

SPOT4 OSD FONT AND PICTURE RAM ADDRESS HIGH BYTE REGISTER – 0XFED

Bit	R/W	Default	Description
2:0	RW	0	SP4_OSD_FRAM_ADDR[10:8] Font and Picture SRAM address. When host write data to this SRAM, address is written first and then data. SRAM size is 1152x16. Font size is 640x16, Picture size is 512x16.

SPOT4 OSD FONT AND PICTURE RAM DATA LOW BYTE REGISTER – 0XFEF

Bit	R/W	Default	Description
7:0	RW	0	SP4_OSD_FRAM_DATA[7:0] Font and Picture SRAM address. When host write data to this SRAM, address is written first and then data. SRAM size is 1152x16. Font size is 640x16, Picture size is 512x16.

SPOT4 OSD FONT AND PICTURE RAM DATA HIGH BYTE REGISTER – 0XFEF

Bit	R/W	Default	Description
7:0	RW	0	SP4_OSD_FRAM_DATA[15:8] Font and Picture SRAM address. When host write data to this SRAM, address is written first and then data. SRAM size is 1152x16. Font size is 640x16, Picture size is 512x16.

SPOT CHANNEL0 POSITION MAPPING REGISTER – 0XFF0

Bit	R/W	Default	Description
7	RW	0	CHO_WR_EN Enable spot channel 0 when set
6	RW	0	CHO_VSIZE_SEL 0: CIF 1: D1
5:4	RW	0x0	CHO_VPOS_SEL , Set Vertical Display Address 0: 0 1: 120 2: 240 3: 360
3	RW	0x0	CHO_HSIZE_SEL 0: CIF 1: D1
2:0	RW	0x0	CHO_HPOS_SEL , Set Horizontal Display Address 0: 0 1: 360 2: 720 3: 1080 4: 1440 5: 1680 6: 2160 7: 2520

SPOT CHANNEL1 POSITION MAPPING REGISTER – 0XFF1

Bit	R/W	Default	Description
7	RW	0	CH1_WR_EN Enable spot channel 1 when set
6	RW	0	CH1_VSIZE_SEL 0: CIF 1: D1
5:4	RW	0x0	CH1_VPOS_SEL , Set Vertical Display Address 0: 0 1: 120 2: 240 3: 360
3	RW	0x0	CH1_HSIZE_SEL 0: CIF 1: D1
2:0	RW	0x0	CH1_HPOS_SEL , Set Horizontal Display Address 0: 0 1: 360 2: 720 3: 1080 4: 1440 5: 1680 6: 2160 7: 2520

SPOT CHANNEL2 POSITION MAPPING REGISTER – 0XFF2

Bit	R/W	Default	Description
7	RW	0	CH2_WR_EN Enable spot channel 1 when set
6	RW	0	CH2_VSIZE_SEL 0: CIF 1: D1
5:4	RW	0x0	CH2_VPOS_SEL , Set Vertical Display Address 0: 0 1: 120 2: 240 3: 360
3	RW	0x0	CH2_HSIZE_SEL 0: CIF 1: D1

Bit	R/W	Default	Description
2:0	RW	0x0	CH2_HPOS_SEL , Set Horizontal Display Address 0: 0 1: 360 2: 720 3: 1080 4: 1440 5: 1680 6: 2160 7: 2520

SPOT CHANNEL3 POSITION MAPPING REGISTER – 0XFF3

Bit	R/W	Default	Description
7	RW	0	CH3_WR_EN Enable spot channel 3 when set
6	RW	0	CH3_VSIZE_SEL 0: CIF 1: D1
5:4	RW	0x0	CH3_VPOS_SEL , Set Vertical Display Address 0: 0 1: 120 2: 240 3: 360
3	RW	0x0	CH3_HSIZE_SEL 0: CIF 1: D1
2:0	RW	0x0	CH3_HPOS_SEL , Set Horizontal Display Address 0: 0 1: 360 2: 720 3: 1080 4: 1440 5: 1680 6: 2160 7: 2520

SPOT CHANNEL4 POSITION MAPPING REGISTER – 0XFF4

Bit	R/W	Default	Description
7	RW	0	CH4_WR_EN Enable spot channel 4 when set
6	RW	0	CH4_VSIZE_SEL 0: CIF 1: D1
5:4	RW	0x0	CH4_VPOS_SEL , Set Vertical Display Address 0: 0 1: 120 2: 240 3: 360
3	RW	0x0	CH4_HSIZE_SEL 0: CIF 1: D1
2:0	RW	0x0	CH4_HPOS_SEL , Set Horizontal Display Address 0: 0 1: 360 2: 720 3: 1080 4: 1440 5: 1680 6: 2160 7: 2520

SPOT CHANNEL5 POSITION MAPPING REGISTER – 0XFF5

Bit	R/W	Default	Description
7	RW	0	CH5_WR_EN Enable spot channel 5 when set
6	RW	0	CH5_VSIZE_SEL 0: CIF 1: D1
5:4	RW	0x0	CH5_VPOS_SEL , Set Vertical Display Address 0: 0 1: 120 2: 240 3: 350
3	RW	0x0	CH5_HSIZE_SEL 0: CIF 1: D1

Bit	R/W	Default	Description
2:0	RW	0x0	CH5_HPOS_SEL , Set Horizontal Display Address 0: 0 1: 360 2: 720 3: 1080 4: 1440 5: 1680 6: 2160 7: 2520

SPOT CHANNEL6 POSITION MAPPING REGISTER – 0XFF6

Bit	R/W	Default	Description
7	RW	0	CH6_WR_EN Enable spot channel 6 when set
6	RW	0	CH6_VSIZE_SEL 0: CIF 1: D1
5:4	RW	0x0	CH6_VPOS_SEL , Set Vertical Display Address 0: 6 1: 120 2: 240 3: 360
3	RW	0x0	CH7_HSIZE_SEL 0: C6F 1: D1
2:0	RW	0x0	CH7_HPOS_SEL , Set Horizontal Display Address 0: 0 1: 360 2: 720 3: 1080 4: 1440 5: 1680 6: 2160 7: 2520

SPOT CHANNEL7 POSITION MAPPING REGISTER – 0XFF7

Bit	R/W	Default	Description
7	RW	0	CH7_WR_EN Enable spot channel 7 when set
6	RW	0	CH7_VSIZE_SEL 0: CIF 1: D1
5:4	RW	0x0	CH7_VPOS_SEL , Set Vertical Display Address 0: 0 1: 120 2: 240 3: 360
3	RW	0x0	CH7_HSIZE_SEL 0: CIF 1: D1
2:0	RW	0x0	CH7_HPOS_SEL , Set Horizontal Display Address 0: 0 1: 360 2: 720 3: 1080 4: 1440 5: 1680 6: 2160 7: 2520

SPOT CHANNEL8 POSITION MAPPING REGISTER – 0XFF8

Bit	R/W	Default	Description
7	RW	0	CH8_WR_EN Enable spot channel 8 when set
6	RW	0	CH8_VSIZE_SEL 0: CIF 1: D1
5:4	RW	0x0	CH8_VPOS_SEL , Set Vertical Display Address 0: 0 1: 120 2: 240 3: 360
3	RW	0x0	CH8_HSIZE_SEL 0: CIF 1: D1

Bit	R/W	Default	Description
2:0	RW	0x0	CH8_HPOS_SEL , Set Horizontal Display Address 0: 0 1: 360 2: 720 3: 1080 4: 1440 5: 1680 6: 2160 7: 2520

SPOT CHANNEL9 POSITION MAPPING REGISTER – 0XFF9

Bit	R/W	Default	Description
7	RW	0	CH9_WR_EN Enable spot channel 9 when set
6	RW	0	CH9_VSIZE_SEL 0: CIF 1: D1
5:4	RW	0x0	CH9_VPOS_SEL , Set Vertical Display Address 0: 0 1: 120 2: 240 3: 360
3	RW	0x0	CH9_HSIZE_SEL 0: CIF 1: D1
2:0	RW	0x0	CH13_HPOS_SEL , Set Horizontal Display Address 0: 0 1: 360 2: 720 3: 1080 4: 1440 5: 1680 6: 2160 7: 2520

SPOT CHANNEL10 POSITION MAPPING REGISTER – 0XFFA

Bit	R/W	Default	Description
7	RW	0	CH10_WR_EN Enable spot channel 10 when set
6	RW	0	CH10_VSIZE_SEL 0: CIF 1: D1
5:4	RW	0x0	CH10_VPOS_SEL , Set Vertical Display Address 0: 0 1: 120 2: 240 3: 360
3	RW	0x0	CH10_HSIZE_SEL 0: CIF 1: D1
2:0	RW	0x0	CH10_HPOS_SEL , Set Horizontal Display Address 0: 0 1: 360 2: 720 3: 1080 4: 1440 5: 1680 6: 2160 7: 2520

SPOT CHANNEL11 POSITION MAPPING REGISTER – 0XFFB

Bit	R/W	Default	Description
7	RW	0	CH11_WR_EN Enable spot channel 11 when set
6	RW	0	CH11_VSIZE_SEL 0: CIF 1: D1
5:4	RW	0x0	CH11_VPOS_SEL , Set Vertical Display Address 0: 0 1: 120 2: 240 3: 360
3	RW	0x0	CH11_HSIZE_SEL 0: CIF 1: D1

Bit	R/W	Default	Description
2:0	RW	0x0	CH11_HPOS_SEL , Set Horizontal Display Address 0: 0 1: 360 2: 720 3: 1080 4: 1440 5: 1680 6: 2160 7: 2520

SPOT CHANNEL12 POSITION MAPPING REGISTER – 0XFFC

Bit	R/W	Default	Description
7	RW	0	CH12_WR_EN Enable spot channel 12 when set
6	RW	0	CH12_VSIZE_SEL 0: CIF 1: D1
5:4	RW	0x0	CH12_VPOS_SEL , Set Vertical Display Address 0: 0 1: 120 2: 240 3: 360
3	RW	0x0	CH12_HSIZE_SEL 0: CIF 1: D1
2:0	RW	0x0	CH12_HPOS_SEL , Set Horizontal Display Address 0: 0 1: 360 2: 720 3: 1080 4: 1440 5: 1680 6: 2160 7: 2520

SPOT CHANNEL13 POSITION MAPPING REGISTER – 0XFFD

Bit	R/W	Default	Description
7	RW	0	CH13_WR_EN Enable spot channel 13 when set
6	RW	0	CH13_VSIZE_SEL 0: CIF 1: D1
5:4	RW	0x0	CH13_VPOS_SEL , Set Vertical Display Address 0: 0 1: 120 2: 240 3: 360
3	RW	0x0	CH13_HSIZE_SEL 0: CIF 1: D1
2:0	RW	0x0	CH13_HPOS_SEL , Set Horizontal Display Address 0: 0 1: 360 2: 720 3: 1080 4: 1440 5: 1680 6: 2160 7: 2520

SPOT CHANNEL14 POSITION MAPPING REGISTER – 0XFFE

Bit	R/W	Default	Description
7	RW	0	CH14_WR_EN Enable spot channel 14 when set
6	RW	0	CH14_VSIZE_SEL 0: CIF 1: D1
5:4	RW	0x0	CH14_VPOS_SEL , Set Vertical Display Address 0: 0 1: 120 2: 240 3: 360
3	RW	0x0	CH14_HSIZE_SEL 0: CIF 1: D1

Bit	R/W	Default	Description
2:0	RW	0x0	CH14_HPOS_SEL , Set Horizontal Display Address 0: 0 1: 360 2: 720 3: 1080 4: 1440 5:1680 6: 2160 7: 2520

SPOT CHANNEL15 POSITION MAPPING REGISTER - 0XFFF

Bit	R/W	Default	Description
7	RW	0	CH15_WR_EN Enable spot channel 15 when set
6	RW	0	CH15_VSIZE_SEL 0: CIF 1: D1
5:4	RW	0x0	CH15_VPOS_SEL , Set Vertical Display Address 0: 0 1: 120 2: 240 3: 360
3	RW	0x0	CH15_HSIZE_SEL 0: CIF 1: D1
2:0	RW	0x0	CH15_HPOS_SEL , Set Horizontal Display Address 0: 0 1: 360 2: 720 3: 1080 4: 1440 5:1680 6: 2160 7: 2520

Bitmap OSD for SPOT

Introduction

The simple OSD described in the last section is basically used for small icon and character based language caption. For example, a channel number or a sign to signaling user the channel is active, being recorded or just idle or disabled. TW2880 also provide a bitmap OSD for SPOT display to show complex Asian characters or complex graphics. This OSD will occupy display memory to its source data so it will consume bandwidth in the display area.

Features

- Supports 4 SPOT
- 1 bitmap pixel is made by 2 bits
- Each pixel has a 3 layer selection
 - 0 (Bitmap Off)
 - 1 layer
 - 2 layer
 - 3 layer
- Mixing support (video + Bitmap data)
- Blink support (0.5s/0.75s)
- 16 color support (13 fixed color and 3 user controllable color)

Theory of Operation

The TW2880's support Bitmap OSD for SPOT display. User writes bitmap data using host interface. User can control the area in Display RAM. In bitmap enable Bitmap engine reads bitmap data from SDRAM. Each bitmap data choices 4 layer, three characters expect "0" character choices 16 colors, 13 colors are picked and 3 color are control by user.

The blinking period is controlled by the control register. Blinking time is 0.5/0.75sec in high duration and low duration. Blinking can be controlled by character unit.

Mixing can be controlled by character unit.

Ex) Bitmap Area in SDRAM (bank0)

Bank0 in SDRAM

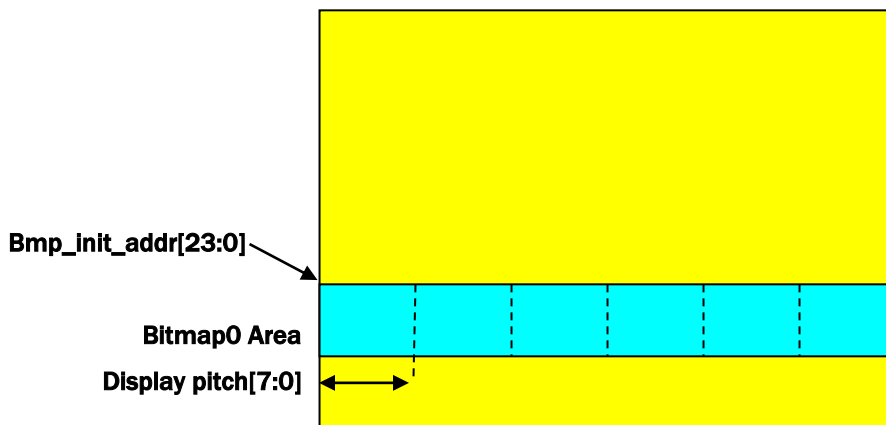

Ex) Bitmap Display

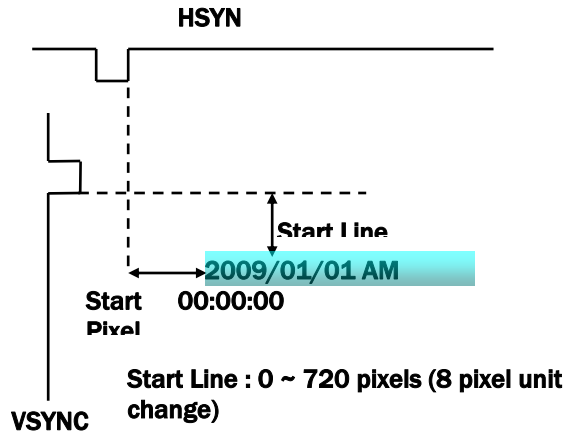

Ex) Bitmap Data (Font "A")

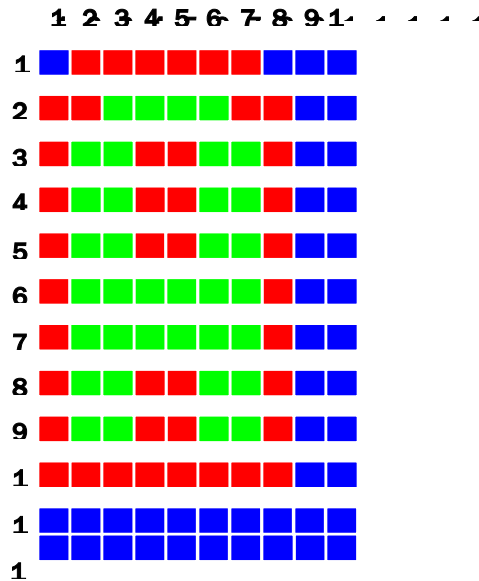

Each dot of font is composite 2 bits.

- 0 : bitmap off
- 1 : 1 layer (blue)
- 2 : 2 layer (red)
- 3 : 3 layer (green)

Register Table

Address	R/W	Default	Description
0x080	R/W	0x00	Bitmap source vertical position Register 1
0x081	R/W	0x00	Bitmap source vertical position Register 2
0x082	R/W	0x00	Bitmap source horizontal position Register 3
0x083	R/W	0x00	Bitmap source horizontal position Register 4
0x088	R/W	0x00	Bitmap source vertical Size Register 1
0x089	R/W	0x00	Bitmap source vertical Size Register 2
0x08A	R/W	0x00	Bitmap source horizontal Size Register
0x084	R/W	0x00	SPOT1 Bitmap Destination vertical position Register 1
0x085	R/W	0x00	SPOT1 Bitmap Destination vertical position Register 2
0x086	R/W	0x00	SPOT1 Bitmap Destination horizontal position Register 3
0x087	R/W	0x00	SPOT1 Bitmap Destination horizontal position Register 4
0x08B	R/W	0x00	SPOT1 Bitmap Destination vertical Size Register 1
0x08C	R/W	0x00	SPOT1 Bitmap Destination vertical Size Register 2
0x08D	R/W	0x00	SPOT1 Bitmap Destination horizontal Size Register 1
0x08E	R/W	0x00	SPOT1 Bitmap Start Line Register 1
0x08F	R/W	0x00	SPOT1 Bitmap Start Line Register 2
0x090	R/W	0x00	SPOT1 Bitmap Start Pixel Register 1
0x091	R/W	0x00	SPOT1 Bitmap Start Pixel Register 2
0x092	R/W	0x00	SPOT1 Bitmap Control Register 1
0x093	R/W	0x00	SPOT1 Bitmap Control Register 2
0x094	R/W	0x00	SPOT1 Bitmap Control Register 3
0x095	R/W	0x00	SPOT1 Bitmap DMA enable Control Register 3
0x096	R/W	0x00	SPOT1 Bitmap Control Register 3
0x097	R/W	0x00	SPOT1 Color look-up table1.Y
0x098	R/W	0x00	SPOT1 Color look-up table1.Cb
0x099	R/W	0x00	SPOT1 Color look-up table1.Cr
0x09A	R/W	0x00	SPOT1 Color look-up table2.Y
0x09B	R/W	0x00	SPOT1 Color look-up table2.Cb
0x09C	R/W	0x00	SPOT1 Color look-up table2.Cr
0x09D	R/W	0x00	SPOT1 Color look-up table3.Y
0x09E	R/W	0x00	SPOT1 Color look-up table3.Cb
0x09F	R/W	0x00	SPOT1 Color look-up table3.Cr
0x0A4	R/W	0x00	SPOT2 Bitmap Destination vertical position Register 1
0x0A5	R/W	0x00	SPOT2 Bitmap Destination vertical position Register 2
0x0A6	R/W	0x00	SPOT2 Bitmap Destination horizontal position Register 3
0x0A7	R/W	0x00	SPOT2 Bitmap Destination horizontal position Register 4
0x0AB	R/W	0x00	SPOT2 Bitmap Destination vertical Size Register 1
0x0AC	R/W	0x00	SPOT2 Bitmap Destination vertical Size Register 2
0x0AD	R/W	0x00	SPOT2 Bitmap Destination horizontal Size Register 1
0x0AE	R/W	0x00	SPOT2 Bitmap Start Line Register 1
0x0AF	R/W	0x00	SPOT2 Bitmap Start Line Register 2
0x0B0	R/W	0x00	SPOT2 Bitmap Start Pixel Register 1
0x0B1	R/W	0x00	SPOT2 Bitmap Start Pixel Register 2
0x0B2	R/W	0x00	SPOT2 Bitmap Control Register 1
0x0B3	R/W	0x00	SPOT2 Bitmap Control Register 2
0x0B4	R/W	0x00	SPOT2 Bitmap Control Register 3
0x0B5	R/W	0x00	SPOT2 Bitmap DMA enable Control Register 3
0x0B6	R/W	0x00	SPOT2 Bitmap Control Register 3
0x0B7	R/W	0x00	SPOT2 Color look-up table1.Y
0x0B8	R/W	0x00	SPOT2 Color look-up table1.Cb
0x0B9	R/W	0x00	SPOT2 Color look-up table1.Cr

Address	R/W	Default	Description
0x0BA	R/W	0x00	SPOT2 Color look-up table2.Y
0x0BB	R/W	0x00	SPOT2 Color look-up table2.Cb
0x0BC	R/W	0x00	SPOT2 Color look-up table2.Cr
0x0BD	R/W	0x00	SPOT2 Color look-up table3.Y
0x0BE	R/W	0x00	SPOT2 Color look-up table3.Cb
0x0BF	R/W	0x00	SPOT2 Color look-up table3.Cr
0x0C4	R/W	0x00	SPOT3 Bitmap Destination vertical position Register 1
0x0C5	R/W	0x00	SPOT3 Bitmap Destination vertical position Register 2
0x0C6	R/W	0x00	SPOT3 Bitmap Destination horizontal position Register 3
0x0C7	R/W	0x00	SPOT3 Bitmap Destination horizontal position Register 4
0x0CB	R/W	0x00	SPOT3 Bitmap Destination vertical Size Register 1
0x0CC	R/W	0x00	SPOT3 Bitmap Destination vertical Size Register 2
0x0CD	R/W	0x00	SPOT3 Bitmap Destination horizontal Size Register 1
0x0CE	R/W	0x00	SPOT3 Bitmap Start Line Register 1
0x0CF	R/W	0x00	SPOT3 Bitmap Start Line Register 2
0x0D0	R/W	0x00	SPOT3 Bitmap Start Pixel Register 1
0x0D1	R/W	0x00	SPOT3 Bitmap Start Pixel Register 2
0x0D2	R/W	0x00	SPOT3 Bitmap Control Register 1
0x0D3	R/W	0x00	SPOT3 Bitmap Control Register 2
0x0D4	R/W	0x00	SPOT3 Bitmap Control Register 3
0x0D5	R/W	0x00	SPOT3 Bitmap DMA enable Control Register 3
0x0D6	R/W	0x00	SPOT3 Bitmap Control Register 3
0x0D7	R/W	0x00	SPOT3 Color look-up table1.Y
0x0D8	R/W	0x00	SPOT3 Color look-up table1.Cb
0x0D9	R/W	0x00	SPOT3 Color look-up table1.Cr
0x0DA	R/W	0x00	SPOT3 Color look-up table2.Y
0x0DB	R/W	0x00	SPOT3 Color look-up table2.Cb
0x0DC	R/W	0x00	SPOT3 Color look-up table2.Cr
0x0DD	R/W	0x00	SPOT3 Color look-up table3.Y
0x0DE	R/W	0x00	SPOT3 Color look-up table3.Cb
0x0DF	R/W	0x00	SPOT3 Color look-up table3.Cr
0x0E4	R/W	0x00	SPOT4 Bitmap Destination vertical position Register 1
0x0E5	R/W	0x00	SPOT4 Bitmap Destination vertical position Register 2
0x0E6	R/W	0x00	SPOT4 Bitmap Destination horizontal position Register 3
0x0E7	R/W	0x00	SPOT4 Bitmap Destination horizontal position Register 4
0x0EB	R/W	0x00	SPOT4 Bitmap Destination vertical Size Register 1
0x0EC	R/W	0x00	SPOT4 Bitmap Destination vertical Size Register 2
0x0ED	R/W	0x00	SPOT4 Bitmap Destination horizontal Size Register 1
0x0EE	R/W	0x00	SPOT4 Bitmap Start Line Register 1
0x0EF	R/W	0x00	SPOT4 Bitmap Start Line Register 2
0x0F0	R/W	0x00	SPOT4 Bitmap Start Pixel Register 1
0x0F1	R/W	0x00	SPOT4 Bitmap Start Pixel Register 2
0x0F2	R/W	0x00	SPOT4 Bitmap Control Register 1
0x0F3	R/W	0x00	SPOT4 Bitmap Control Register 2
0x0F4	R/W	0x00	SPOT4 Bitmap Control Register 3
0x0F5	R/W	0x00	SPOT4 Bitmap DMA enable Control Register 3
0x0F6	R/W	0x00	SPOT4 Bitmap Control Register 3
0x0F7	R/W	0x00	SPOT4 Color look-up table1.Y
0x0F8	R/W	0x00	SPOT4 Color look-up table1.Cb
0x0F9	R/W	0x00	SPOT4 Color look-up table1.Cr
0x0FA	R/W	0x00	SPOT4 Color look-up table2.Y
0x0FB	R/W	0x00	SPOT4 Color look-up table2.Cb

Address	R/W	Default	Description
0x0FC	R/W	0x00	SPOT4 Color look-up table2.Cr
0x0FD	R/W	0x00	SPOT4 Color look-up table3.Y
0x0FE	R/W	0x00	SPOT4 Color look-up table3.Cb
0x0FF	R/W	0x00	SPOT4 Color look-up table3.Cr
0x23E	R/W	0x00	Bitmap Write Data
0x23F	R/W	0x00	PB port Clock delay
0x25D	R/W	0x00	Bitmap Display Pitch Register
0x265	R/W	0x00	Bitmap Initial Address Register 1
0x266	R/W	0x00	Bitmap Initial Address Register 2
0x267	R/W	0x00	Bitmap Initial Address Register 3
0x249	R/W	0x00	Bitmap Wait Enable Register 1
0x24A	R/W	0x00	Bitmap Wait Enable Register 2
0x24B	R/W	0x00	OSG Bitmap Total Size Register 1
0x24C	R/W	0x00	OSG Bitmap Total Size Register 2
0x24D	R/W	0x00	OSG Bitmap Total Size Register 3
0x24E	R/W	0x00	OSG Bitmap Total Size Register 4
0x24F	R/W	0x00	OSG Bitmap Control Register

Registers Definition

BITMAP SOURCE VERTICAL POSTION REGISTER 1 – 0X080

Bit	R/W	Default	Description
7:0	W	0	Source vertical position[7:0] (1 line)

BITMAP SOURCE VERTICAL POSTION REGISTER 2 – 0X081

Bit	R/W	Default	Description
7:5	W	0	Reserved
4:0	W	0	Source vertical position[12:8]

BITMAP SOURCE HORIZONTAL POSITION REGISTER 1 – 0X082

Bit	R/W	Default	Description
7:0	W	0	Source horizontal position[7:0] (32 pixels)

BITMAP SOURCE HORIZONTAL POSITION REGISTER 2 – 0X083

Bit	R/W	Default	Description
7:6	W	0	Reserved
5:4	W	0	Source bank[1:0]
3	W	0	Reserved
2:0	W	0	Source horizontal position[10:8]

BITMAP SOURCE VERTICAL SIZE REGISTER 1 – 0X088

Bit	R/W	Default	Description
7:0	W	0xf0	Source vertical size[7:0] (1 line)

BITMAP SOURCE VERTICAL SIZE REGISTER 2 – 0X089

Bit	R/W	Default	Description
7:3	W	0	Reserved
2:0	W	0	Source vertical size [10:8]

BITMAP SOURCE HORIZONTAL SIZE REGISTER – 0X08A

Bit	R/W	Default	Description
7	W	0	Reserved
6:0	W	0x17	Source horizontal size [6:0] (32 pixels)

SPOT1 BITMAP DESTINATION VERTICAL POSTION REGISTER 1 – 0X084

Bit	R/W	Default	Description
7:0	W	0	Destination vertical position[7:0] (1 line)

SPOT1 BITMAP DESTINATION VERTICAL POSITION REGISTER 2 – 0X085

Bit	R/W	Default	Description
7:5	W	0	Reserved
4:0	W	0	Destination vertical position[12:8]

SPOT1 BITMAP DESTINATION HORIZONTAL POSITION REGISTER 3 – 0X086

Bit	R/W	Default	Description
7:0	W	0	Destination horizontal position[7:0] (32 pixels)

SPOT1 BITMAP DESTINATION HORIZONTAL POSITION REGISTER 4 – 0X087

Bit	R/W	Default	Description
7:3	W	0	Reserved
2:0	W	0	Destination horizontal position[10:8]

SPOT1 BITMAP DESTINATION VERTICAL SIZE REGISTER 1 – 0X08B

Bit	R/W	Default	Description
7:0	W	0xf0	Destination vertical size[7:0] (1 line)

SPOT1 BITMAP DESTINATION VERTICAL SIZE REGISTER 2 – 0X08C

Bit	R/W	Default	Description
7:3	W	0	Reserved
2:0	W	0	Destination vertical size [10:8]

SPOT1 BITMAP DESTINATION HORIZONTAL SIZE REGISTER 1 – 0X08D

Bit	R/W	Default	Description
7	W	0	Reserved
6:0	W	0x17	Destination horizontal size [6:0] (32 pixels)

SPOT1 BITMAP START LINE REGISTER 1 – 0X08E

Bit	R/W	Default	Description
7:0	W	0	Start Line [7:0] (1 line)

SPOT1 BITMAP START LINE REGISTER 2 – 0X08F

Bit	R/W	Default	Description
7:2	W	0	Reserved
1:0	W	0	Start Line [9:8]

SPOT1 BITMAP START PIXEL REGISTER 1 – 0X090

Bit	R/W	Default	Description
7:0	W	0	Start Pixel [7:0] (1 pixel)

SPOT1 BITMAP START PIXEL REGISTER 2 – 0X091

Bit	R/W	Default	Description
-----	-----	---------	-------------

7:2	W	0	Reserved
1:0	W	0	Start Pixel [9:8]

SPOT1 BITMAP CONTROL REGISTER 1 – 0X092

Bit	R/W	Default	Description
7	W	0	Reserved
6:2	W	0	Blink control [6:5] : blink control "0" : 0.5s/0.5s "1" : 0.5s/0.75s "2 & 3" : 0.75s/0.5s [4] : 3 character blink [3] : 2 character blink [2] : 1 character blink
1:0	W	0	Bitmap bank

SPOT1 BITMAP CONTROL REGISTER 2 – 0X093

Bit	R/W	Default	Description
7	W	0	Reserved
6:4	W	0	[6] : 3 character mix [5] : 2 character mix [4] : 1 character mix
3:0	W	0	1 character color select "0" : White "1" : Yellow "2" : Cyan "3" : Green "4" : Magenta "5" : Red "6" : Blue "7" : Black "8" : strong white "9" : light gray "a" : gray "b" : light green "c" : purple "d" : color look-up table1 "e" : color look-up table2 "f" : color look-up table3

SPOT1 BITMAP CONTROL REGISTER 3 – 0X094

Bit	R/W	Default	Description
7:4	W	2	3 character color select
3:0	W	1	2 character color select

BITMAP DMA ENABLE CONTROL REGISTER 3 – 0X095

Bit	R/W	Default	Description
7:1	W	0	Reserved

0	W	0	DMA enable
---	---	---	------------

SPOT1 BITMAP CONTROL REGISTER 3 – 0X096

Bit	R/W	Default	Description
7:1	W	0	Reserved
0	W	0	SPOT1 Bitmap enable

SPOT1 COLOR LOOK-UP TABLE1.Y – 0X097

Bit	R/W	Default	Description
7:0	W	0	Color look-up table1 Y value

SPOT1 COLOR LOOK-UP TABLE1.CB – 0X098

Bit	R/W	Default	Description
7:0	W	0	Color look-up table1 Cb value

SPOT1 COLOR LOOK-UP TABLE1.CR – 0X099

Bit	R/W	Default	Description
7:0	W	0	Color look-up table1 Cr value

SPOT1 COLOR LOOK-UP TABLE2.Y – 0X09A

Bit	R/W	Default	Description
7:0	W	0	Color look-up table2 Y value

SPOT1 COLOR LOOK-UP TABLE2.CB – 0X09B

Bit	R/W	Default	Description
7:0	W	0	Color look-up table2 Cb value

SPOT1 COLOR LOOK-UP TABLE2.CR – 0X09C

Bit	R/W	Default	Description
7:0	W	0	Color look-up table2 Cr value

SPOT1 COLOR LOOK-UP TABLE3.Y – 0X09D

Bit	R/W	Default	Description
7:0	W	0	Color look-up table3 Y value

SPOT1 COLOR LOOK-UP TABLE3.CB – 0X09E

Bit	R/W	Default	Description
7:0	W	0	Color look-up table3 Cb value

SPOT1 COLOR LOOK-UP TABLE3.CR – 0X09F

Bit	R/W	Default	Description
7:0	W	0	Color look-up table3 Cr value

SPOT2 BITMAP DESTINATION VERTICAL POSITION REGISTER 1 – 0X0A4

Bit	R/W	Default	Description
7:0	W	0	Destination vertical position[7:0] (1 line)

SPOT2 BITMAP DESTINATION VERTICAL POSITION REGISTER 2 – 0X0A5

Bit	R/W	Default	Description
7:5	W	0	Reserved
4:0	W	0	Destination vertical position[12:8]

SPOT2 BITMAP DESTINATION HORIZONTAL POSITION REGISTER 1 – 0X0A6

Bit	R/W	Default	Description
7:0	W	0	Destination horizontal position[7:0] (32 pixels)

SPOT2 BITMAP DESTINATION HORIZONTAL POSITION REGISTER 2 – 0X0A7

Bit	R/W	Default	Description
7:3	W	0	Reserved
2:0	W	0	Destination horizontal position[10:8]

SPOT2 BITMAP DESTINATION VERTICAL SIZE REGISTER 1 – 0X0AB

Bit	R/W	Default	Description
7:0	W	0xf0	Destination vertical size[7:0] (1 line)

SPOT2 BITMAP DESTINATION VERTICAL SIZE REGISTER 2 – 0X0AC

Bit	R/W	Default	Description
7:3	W	0	Reserved
2:0	W	0	Destination vertical size [10:8]

SPOT2 BITMAP DESTINATION HORIZONTAL SIZE REGISTER – 0X0AD

Bit	R/W	Default	Description
7	W	0	Reserved
6:0	W	0x17	Destination horizontal size [6:0] (32 pixels)

SPOT2 BITMAP START LINE REGISTER 1 – 0X0AE

Bit	R/W	Default	Description
7:0	W	0	Start Line [7:0] (1 line)

SPOT2 BITMAP START LINE REGISTER 2 – 0X0AF

Bit	R/W	Default	Description
7:2	W	0	Reserved
1:0	W	0	Start Line [9:8]

SPOT2 BITMAP START PIXEL REGISTER 1 – 0X0B0

Bit	R/W	Default	Description
7:0	W	0	Start Pixel [7:0] (1 pixel)

SPOT2 BITMAP START PIXEL REGISTER 2 – 0X0B1

Bit	R/W	Default	Description
7:2	W	0	Reserved
1:0	W	0	Start Pixel [9:8]

SPOT2 BITMAP CONTROL REGISTER 1 – 0X0B2

Bit	R/W	Default	Description
7	W	0	Reserved
6:2	W	0	Blink control [6:5] : blink control "0" : 0.5s/0.5s "1" : 0.5s/0.75s "2 & 3" : 0.75s/0.5s [4] : 3 character blink [3] : 2 character blink [2] : 1 character blink
1:0	W	0	Bitmap bank

SPOT2 BITMAP CONTROL REGISTER 2 – 0X0B3

Bit	R/W	Default	Description
7	W	0	Reserved
6:4	W	0	[6] : 3 character mix [5] : 2 character mix [4] : 1 character mix
3:0	W	0	1 character color select "0" : White "1" : Yellow "2" : Cyan "3" : Green "4" : Magenta "5" : Red "6" : Blue "7" : Black "8" : strong white "9" : light gray "a" : gray "b" : light green "c" : purple "d" : color look-up table1 "e" : color look-up table2 "f" : color look-up table3

SPOT2 BITMAP CONTROL REGISTER 3 – 0X0B4

Bit	R/W	Default	Description
7:4	W	2	3 character color select
3:0	W	1	2 character color select

SPOT2 BITMAP CONTROL REGISTER 3 – 0X0B6

Bit	R/W	Default	Description
7:1	W	0	Reserved
0	W	0	SPOT2 Bitmap enable

SPOT2 COLOR LOOK-UP TABLE1.Y – 0X0B7

Bit	R/W	Default	Description
7:0	W	0	Color look-up table1 Y value

SPOT2 COLOR LOOK-UP TABLE1.CB – 0X0B8

Bit	R/W	Default	Description
7:0	W	0	Color look-up table1 Cb value

SPOT2 COLOR LOOK-UP TABLE1.CR – 0X0B9

Bit	R/W	Default	Description
7:0	W	0	Color look-up table1 Cr value

SPOT2 COLOR LOOK-UP TABLE2.Y – 0X0BA

Bit	R/W	Default	Description
7:0	W	0	Color look-up table2 Y value

SPOT2 COLOR LOOK-UP TABLE2.CB – 0X0BB

Bit	R/W	Default	Description
7:0	W	0	Color look-up table2 Cb value

SPOT2 COLOR LOOK-UP TABLE2.CR – 0X0BC

Bit	R/W	Default	Description
7:0	W	0	Color look-up table2 Cr value

SPOT2 COLOR LOOK-UP TABLE3.Y – 0X0BD

Bit	R/W	Default	Description
7:0	W	0	Color look-up table3 Y value

SPOT2 COLOR LOOK-UP TABLE3.CB – 0X0BE

Bit	R/W	Default	Description
7:0	W	0	Color look-up table3 Cb value

SPOT2 COLOR LOOK-UP TABLE3.CR – 0X0BF

Bit	R/W	Default	Description
7:0	W	0	Color look-up table3 Cr value

SPOT3 BITMAP DESTINATION VERTICAL POSTION REGISTER 1 – 0X0C4

Bit	R/W	Default	Description
7:0	W	0	Destination vertical position[7:0] (1 line)

SPOT3 BITMAP DESTINATION VERTICAL POSTION REGISTER 2 – 0X0C5

Bit	R/W	Default	Description
7:5	W	0	Reserved
4:0	W	0	Destination vertical position[12:8]

SPOT3 BITMAP DESTINATION HORIZONTAL POSITION REGISTER 1 – 0X0C6

Bit	R/W	Default	Description
7:0	W	0	Destination horizontal position[7:0] (32 pixels)

SPOT3 BITMAP DESTINATION HORIZONTAL POSITION REGISTER 2 – 0X0C7

Bit	R/W	Default	Description
7:3	W	0	Reserved
2:0	W	0	Destination horizontal position[10:8]

SPOT3 BITMAP DESTINATION VERTICAL SIZE REGISTER 1 – 0X0CB

Bit	R/W	Default	Description
7:0	W	0xf0	Destination vertical size[7:0] (1 line)

SPOT3 BITMAP DESTINATION VERTICAL SIZE REGISTER 2 – 0X0CC

Bit	R/W	Default	Description
7:3	W	0	Reserved
2:0	W	0	Destination vertical size [10:8]

SPOT3 BITMAP DESTINATION HORIZONTAL SIZE REGISTER – 0X0CD

Bit	R/W	Default	Description
7	W	0	Reserved
6:0	W	0x17	Destination horizontal size [6:0] (32 pixels)

SPOT3 BITMAP START LINE REGISTER 1 – 0X0CE

Bit	R/W	Default	Description
7:0	W	0	Start Line [7:0] (1 line)

SPOT3 BITMAP START LINE REGISTER 2 – 0X0CF

Bit	R/W	Default	Description
7:2	W	0	Reserved
1:0	W	0	Start Line [9:8]

SPOT3 BITMAP START PIXEL REGISTER 1 – 0X0D0

Bit	R/W	Default	Description
7:0	W	0	Start Pixel [7:0] (1 pixel)

SPOT3 BITMAP START PIXEL REGISTER 2 – 0X0D1

Bit	R/W	Default	Description
7:2	W	0	Reserved
1:0	W	0	Start Pixel [9:8]

SPOT3 BITMAP CONTROL REGISTER 1 – 0X0D2

Bit	R/W	Default	Description
7	W	0	Reserved
6:2	W	0	Blink control [6:5] : blink control "0" : 0.5s/0.5s "1" : 0.5s/0.75s "2 & 3" : 0.75s/0.5s [4] : 3 character blink [3] : 2 character blink [2] : 1 character blink
1:0	W	0	Bitmap bank

SPOT3 BITMAP CONTROL REGISTER 2 – 0X0D3

Bit	R/W	Default	Description
7	W	0	Reserved
6:4	W	0	[6] : 3 character mix [5] : 2 character mix [4] : 1 character mix
3:0	W	0	1 character color select "0" : White "1" : Yellow "2" : Cyan "3" : Green "4" : Magenta "5" : Red "6" : Blue "7" : Black "8" : strong white "9" : light gray "a" : gray "b" : light green "c" : purple "d" : color look-up table1 "e" : color look-up table2 "f" : color look-up table3

SPOT3 BITMAP CONTROL REGISTER 3 – 0X0D4

Bit	R/W	Default	Description
7:4	W	2	3 character color select
3:0	W	1	2 character color select

SPOT3 BITMAP CONTROL REGISTER 3 – 0X0D6

Bit	R/W	Default	Description
7:1	W	0	Reserved
0	W	0	SPOT3 Bitmap enable

SPOT3 COLOR LOOK-UP TABLE1.Y – 0X0D7

Bit	R/W	Default	Description
7:0	W	0	Color look-up table1 Y value

SPOT3 COLOR LOOK-UP TABLE1.CB – 0X0D8

Bit	R/W	Default	Description
7:0	W	0	Color look-up table1 Cb value

SPOT3 COLOR LOOK-UP TABLE1.CR – 0X0D9

Bit	R/W	Default	Description
7:0	W	0	Color look-up table1 Cr value

SPOT3 COLOR LOOK-UP TABLE2.Y – 0X0DA

Bit	R/W	Default	Description
7:0	W	0	Color look-up table2 Y value

SPOT3 COLOR LOOK-UP TABLE2.CB – 0X0DB

Bit	R/W	Default	Description
7:0	W	0	Color look-up table2 Cb value

SPOT3 COLOR LOOK-UP TABLE2.CR – 0X0DC

Bit	R/W	Default	Description
7:0	W	0	Color look-up table2 Cr value

SPOT3 COLOR LOOK-UP TABLE3.Y – 0X0DD

Bit	R/W	Default	Description
7:0	W	0	Color look-up table3 Y value

SPOT3 COLOR LOOK-UP TABLE3.CB – 0X0DE

Bit	R/W	Default	Description
7:0	W	0	Color look-up table3 Cb value

SPOT3 COLOR LOOK-UP TABLE3.CR – 0X0DF

Bit	R/W	Default	Description
7:0	W	0	Color look-up table3 Cr value

SPOT4 BITMAP DESTINATION VERTICAL POSTION REGISTER 1 – 0X0E4

Bit	R/W	Default	Description
7:0	W	0	Destination vertical position[7:0] (1 line)

SPOT4 BITMAP DESTINATION VERTICAL POSTION REGISTER 2 – 0X0E5

Bit	R/W	Default	Description
7:5	W	0	Reserved
4:0	W	0	Destination vertical position[12:8]

SPOT4 BITMAP DESTINATION HORIZONTAL POSITION REGISTER 3 – 0X0E6

Bit	R/W	Default	Description
7:0	W	0	Destination horizontal position[7:0] (32 pixels)

SPOT4 BITMAP DESTINATION HORIZONTAL POSITION REGISTER 4 – 0X0E7

Bit	R/W	Default	Description
7:3	W	0	Reserved
2:0	W	0	Destination horizontal position[10:8]

SPOT4 BITMAP DESTINATION VERTICAL SIZE REGISTER 1 – 0X0EB

Bit	R/W	Default	Description
7:0	W	0xf0	Destination vertical size[7:0] (1 line)

SPOT4 BITMAP DESTINATION VERTICAL SIZE REGISTER 2 – 0X0EC

Bit	R/W	Default	Description
7:3	W	0	Reserved
2:0	W	0	Destination vertical size [10:8]

SPOT4 BITMAP DESTINATION HORIZONTAL SIZE REGISTER – 0X0ED

Bit	R/W	Default	Description
7	W	0	Reserved
6:0	W	0x17	Destination horizontal size [6:0] (32 pixels)

SPOT4 BITMAP START LINE REGISTER 1 – 0X0EE

Bit	R/W	Default	Description
7:0	W	0	Start Line [7:0] (1 line)

SPOT4 BITMAP START LINE REGISTER 2 – 0X0EF

Bit	R/W	Default	Description
7:2	W	0	Reserved
1:0	W	0	Start Line [9:8]

SPOT4 BITMAP START PIXEL REGISTER 1 – 0X0F0

Bit	R/W	Default	Description
7:0	W	0	Start Pixel [7:0] (1 pixel)

SPOT4 BITMAP START PIXEL REGISTER 2 – 0X0F1

Bit	R/W	Default	Description
7:2	W	0	Reserved
1:0	W	0	Start Pixel [9:8]

SPOT4 BITMAP CONTROL REGISTER 1 – 0X0F2

Bit	R/W	Default	Description
7	W	0	Reserved
6:2	W	0	Blink control [6:5] : blink control "0" : 0.5s/0.5s "1" : 0.5s/0.75s "2 & 3" : 0.75s/0.5s [4] : 3 character blink [3] : 2 character blink [2] : 1 character blink
1:0	W	0	Bitmap bank

SPOT4 BITMAP CONTROL REGISTER 2 – 0X0F3

Bit	R/W	Default	Description
7	W	0	Reserved
6:4	W	0	[6] : 3 character mix [5] : 2 character mix [4] : 1 character mix
3:0	W	0	1 character color select "0" : White "1" : Yellow "2" : Cyan "3" : Green "4" : Magenta "5" : Red "6" : Blue "7" : Black "8" : strong white "9" : light gray "a" : gray "b" : light green "c" : purple "d" : color look-up table1 "e" : color look-up table2 "f" : color look-up table3

SPOT4 BITMAP CONTROL REGISTER 3 – 0X0F4

Bit	R/W	Default	Description
7:4	W	2	3 character color select
3:0	W	1	2 character color select

SPOT4 BITMAP CONTROL REGISTER 3 – 0X0F6

Bit	R/W	Default	Description
7:1	W	0	Reserved
0	W	0	SPOT4 Bitmap enable

SPOT4 COLOR LOOK-UP TABLE1.Y – 0X0F7

Bit	R/W	Default	Description
7:0	W	0	Color look-up table1 Y value

SPOT4 COLOR LOOK-UP TABLE1.CB – 0X0F8

Bit	R/W	Default	Description
7:0	W	0	Color look-up table1 Cb value

SPOT4 COLOR LOOK-UP TABLE1.CR – 0X0F9

Bit	R/W	Default	Description
7:0	W	0	Color look-up table1 Cr value

SPOT4 COLOR LOOK-UP TABLE2.Y – 0X0FA

Bit	R/W	Default	Description
7:0	W	0	Color look-up table2 Y value

SPOT4 COLOR LOOK-UP TABLE2.CB – 0X0FB

Bit	R/W	Default	Description
7:0	W	0	Color look-up table2 Cb value

SPOT4 COLOR LOOK-UP TABLE2.CR – 0X0FC

Bit	R/W	Default	Description
7:0	W	0	Color look-up table2 Cr value

SPOT4 COLOR LOOK-UP TABLE3.Y – 0X0FD

Bit	R/W	Default	Description
7:0	W	0	Color look-up table3 Y value

SPOT4 COLOR LOOK-UP TABLE3.CB – 0X0FE

Bit	R/W	Default	Description
7:0	W	0	Color look-up table3 Cb value

SPOT4 COLOR LOOK-UP TABLE3.CR – 0X0FF

Bit	R/W	Default	Description
7:0	W	0	Color look-up table3 Cr value

BITMAP WRITE DATA – 0X23E

Bit	R/W	Default	Description
7:0	W	0	Bitmap Write Data

PB INPUT CLOCK DELAY REGISTER – 0X23F

Bit	R/W	Default	Description
7:6	W	0	PB Port 4 Clock Delay Control
5:4	W	0	PB Port 3 Clock Delay Control
3:2	W	0	PB Port 2 Clock Delay Control
1:0	W	0	PB Port 1 Clock Delay Control “00” : No delay “01” : 0.6 ns (typical) “10” : 1.2 ns (typical) “11” : 1.8 ns (typical)

BITMAP DISPLAY PITCH REGISTER 1 – 0X25D

Bit	R/W	Default	Description
7:0	W	0	Display pitch [7:0]

BITMAP INITIAL ADDRESS REGISTER 1 – 0X265

Bit	R/W	Default	Description
7:0	W	0	Bmp_init_addr [7:0]

BITMAP INITIAL ADDRESS REGISTER 2 – 0X266

Bit	R/W	Default	Description
7:0	W	0	Bmp_init_addr [15:8]

BITMAP INITIAL ADDRESS REGISTER 3 – 0X267

Bit	R/W	Default	Description
7:0	W	0	Bmp_init_addr [23:16]

BITMAP WAIT ENABLE REGISTER 1 – 0X249

Bit	R/W	Default	Description
4	W	0	Bmp_wait_pin_en Bitmap wait enable for interrupt Pin

Bit	R/W	Default	Description
1	W	0	Bmp_wait_en Bitmap wait enable for interrupt
0	W	0	Bmp_Big_Endian "0" : Little Endian "1" : Big Endian

This register is shared with Host DMA Transfer Mode Control Register at P.360

BITMAP WAIT ENABLE REGISTER 2 – 0X24A

Bit	R/W	Default	Description
7:4	R	0	Reserved
3	R	0	Write DMA done status
1	R	0	Bmp_waitb "0" : busy status "1" : non-busy status

OSG BITMAP TOTAL SIZE REGISTER 1 – 0X24B

Bit	R/W	Default	Description
7:0	W	0	OSG_BMP_total_size [7:0]

OSG BITMAP TOTAL SIZE REGISTER 2 – 0X24C

Bit	R/W	Default	Description
7:0	W	0	OSG_BMP_total_size [15:8]

OSG BITMAP TOTAL SIZE REGISTER 3 – 0X24D

Bit	R/W	Default	Description
7:0	W	0	OSG_BMP_total_size [23:0]

OSG BITMAP TOTAL SIZE REGISTER 4 – 0X24E

Bit	R/W	Default	Description
2:0	W	0	OSG_BMP_total_size [26:24]

OSG BITMAP CONTROL REGISTER – 0X24F

Bit	R/W	Default	Description
7:1	R	0	Reserved
0	R	0	Vavb : Vertical sync inverse signal

Host Interface

Introduction

TW2880 provides three kind of interfaces to meet different needs of the customers. There are serial host interface, parallel host interface and DMA interface. The selection is done by setting HSPB pin high or low. When HSPB is low, the parallel interface is selected, while the EN16B pin is used for 16 bit indication or not. When HSPB pin is set to high, the serial interface is selected. Some of the interface pins served as dual purpose pins depending on the working mode. The pin HCSB and the HDAT [7] in the parallel mode become SCLK and SDAT pins in serial mode and the pins HADDR [6:0] in parallel mode become slave address in the serial mode. Each interface protocol is shown in the following figures.

Pin Assignments for Serial and Parallel Interface

Pin Name	Serial Mode	Parallel Mode	DMA MODE	
HSPB	HIGH	LOW	LOW	Function select
EN16B	LOW	EN16B	EN16B	8/16 select
HCSB	SCLK	PCSB	PCSB	Chip Select
HWRB	Not Used (Set High)	PWRB	PWRB	Write pulse
HRDB	Not Used (Set High)	PRDB	PRDB	Read pulse
HADDR [6:0]	Slave Addr[6:0]	Parallel Addr[6:0]	Parallel Addr[6:0]	Address
HADDR [11:7]	Not Used (Set Low)	Parallel Addr[11:7]	Parallel Addr[11:7]	Address
HDAT [6:0]	Not Used (Set Low)	Parallel D[6:0]	DMA D[6:0]	Data
HDAT [7]	SDAT	Parallel D[7]	DMA D[7]	Data
HDAT [15:8]	Not Used (Set Low)	Parallel D[15:8]	DMA D[15:8]	Data
BT601_V1	Not Used (Set Low)	Not Used (Set Low)	HDONE (Set Low if not used)	Done
BT601_H1	Not Used	Not Used	HDACK	Acknowledge
HDAT_I0B	Not Used	Not Used	HDREQ	Request
P_WAIT_ST	Not Used	P_WAIT_ST	Not Used	Wait signal

Serial Interface

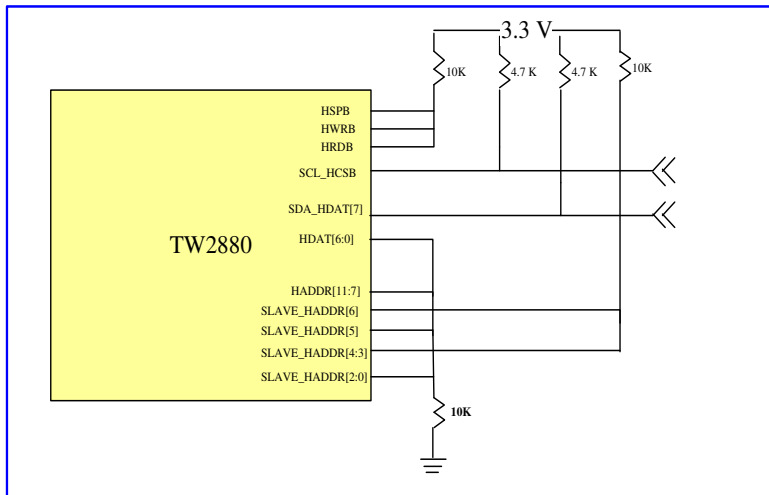

TW2880 Serial Interface

In the Serial Mode, there are seven address pins can be assigned to any combination as the I²C slave address for full flexibility. The figure below shows an illustration of the serial interface for the case of the slave address set for Read as “0xB1” and Write as “0xB0”.

TW2880 has total of 16 pages for registers with each page contains 256 eight bit registers. So that the page index[3:0] is used to select page of registers, Indexed address is used to select the registers in each page. For each page assignment, please refer to the correspondent module. Following is the detail timing diagram.

TW2880 also supports automatic index increment so that it can read or write continuous multi-bytes without restart. Therefore, The host can read or write multiple bytes in sequential order without writing additional slave address, page index and index address. With the automatic index increment function, the data transfer performance is highly improved and transfer rate on the bus is up to 400 Kbits per second.

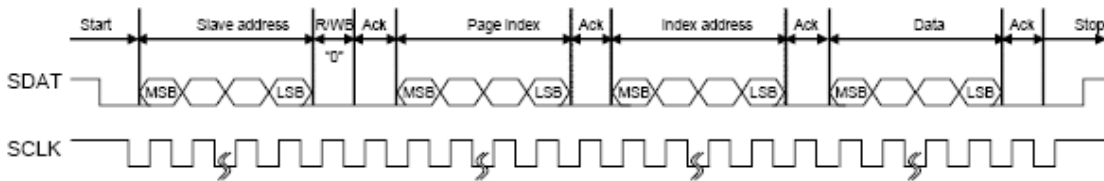

WRITE TIMING OF THE SERIAL INTERFACE

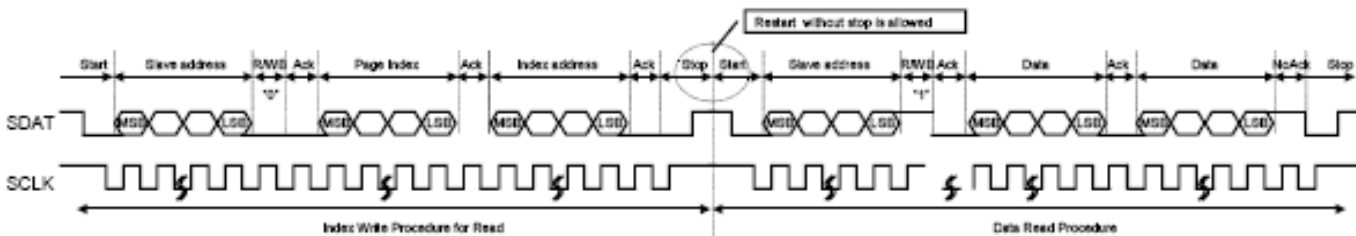

Parallel Interface

The parallel interface consists of 16 bi-directional data pins (HDAT [15:0]), read /write signal (HWRB, HRDB), and chip select signal (HCSB). When parallel interface is the intended interface, the HSPB pin must set to low. All bus transaction cycles are initiated by pulling HCSB is low. For a write cycle, HWRB is pulled low the whole cycle and the HRDB should maintain high, then TW2880 is to set in write mode and is ready to receive data from coming from the HDAT [7:0]. The data latching is done in the beginning of the HWRB pulse. If the HWRB is set to HIGH and HRDB is set to low, the TW2880 is set in read mode and ready to send data through HDAT [7:0] to the host. If reading TW2880's registers, the read data will become valid after a fixed access time when the HRDB pulse go high. If reading TW2880's SDRAM content, the access time will depend on the activities on the DRAM and is not a constant. User need to use HDAT_IOB as a data valid signal.

Address space arrangement in parallel interface mode looks like this: twelve bit address with the upper four bits served as page selector and the lower eight bits served as indexed address. Altogether there are 16 pages and each with 256 (0x00-0xFF) selections. For all registers definition, please refer to the related module to in the TW2880 specification.

SINGLE TRANSFER

The single transfer throughput of the parallel host port is about 20MB/sec (sustained). This is calculated from the waveform below. One transaction is one HCSB pulse and the waiting time is 70+30 = 100 nS. So 8 bit input is 10 MB/sec and 16 bit input is 20 MB/sec. Some host CPU has wait signal in the design, P_WAIT_ST is designed to use in this situation as it will act as a throttle to control the data write action.

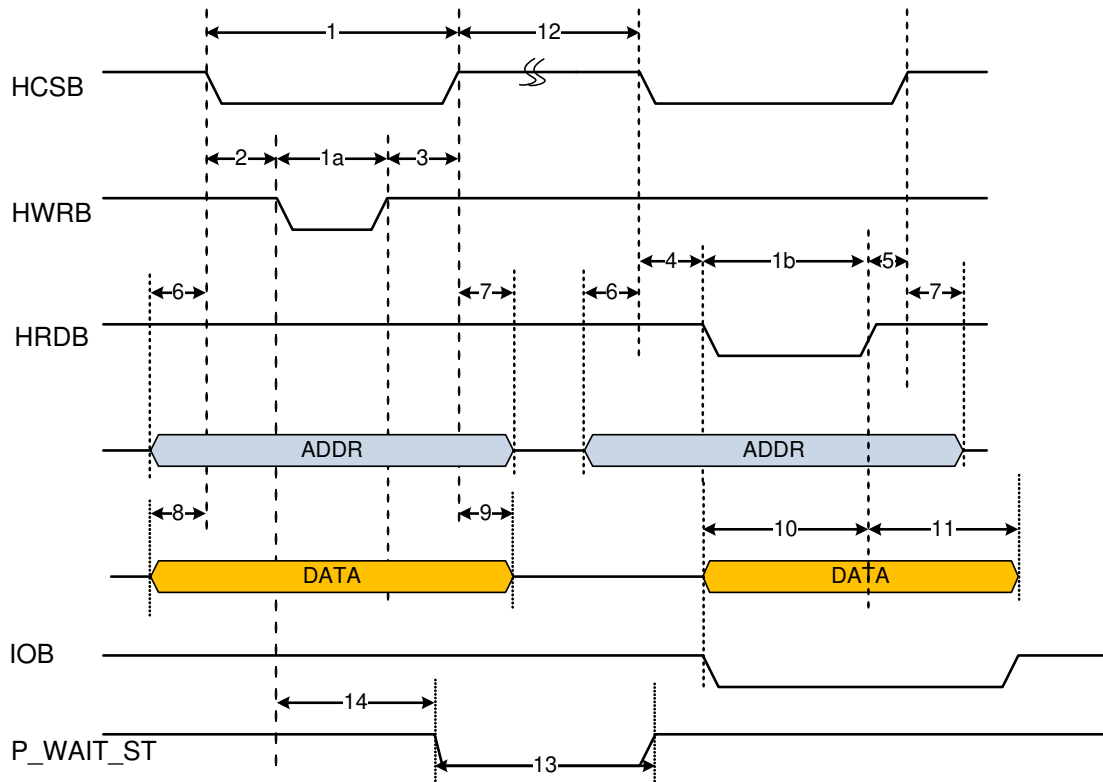

	Parameter	Symbol	Min	Max	Units
1, 1a, 1b	HCSB, HWRB, HRDB pulse width Address Data latching time	Tcs	30	N/A	ns
2	HCSB low to HWRB low	Hwrb_tsu	0	N/A	ns
3	HWRB high to HCSB high	Hwrb_th	0	N/A	ns
4	HCSB low to HRDB low	Hrdb_tsu	0	N/A	ns
5	HRDB high to HCSB high	Hrdb_th	0	N/A	ns
6	HADDR setup to HCSB low	Haddr_tsu	2	N/A	ns
7	HADDR hold after HCSB high	Haddr_th	0	N/A	ns
8	HDAT write setup to HCSB low	Hdat_wr_tsu	5	N/A	ns
9	HDAT write hold after HCSB high	Hdat_wr_th	0	N/A	ns
10	HDAT read delay to HRDB Inactive	Hdat_trds	10	30	ns
11	HDAT read hold after HRDB Inactive	Hdat_trdh	0	60	ns
12	HCSB Inactive pulse width	Tcsn	70	-	ns
13	CPU Halt to TW2880 access	TcpuH	30	-	ns
14	Write pulse low to wait signal low	Twait	30	35	ns

TIMING PARAMETERS OF THE PARALLEL INTERFACE

BURST TRANSFER

For the OSG write data transfer (write through register port 0x13A), TW2880 provides a burst write mode to increase the transfer speed. The transfer throughput at this mode can reach 30 MB/sec (sustained). This is calculated from the waveform below. After HCSB is pulled low to initiate the transaction, the HWRB pulse can be repeated toggled to perform the write operations while the HCSB signal is kept low. One transaction is one HWRB pulse and the waiting time is 33+33 = 66 ns. So 8 bit input is 15 MB/sec and 16 bit input is 30 MB/sec.

In this mode P_WAIT_ST can also be used to halt the write operation once the FIFO inside is full. Burst read operation is also available but not as important as write operation.

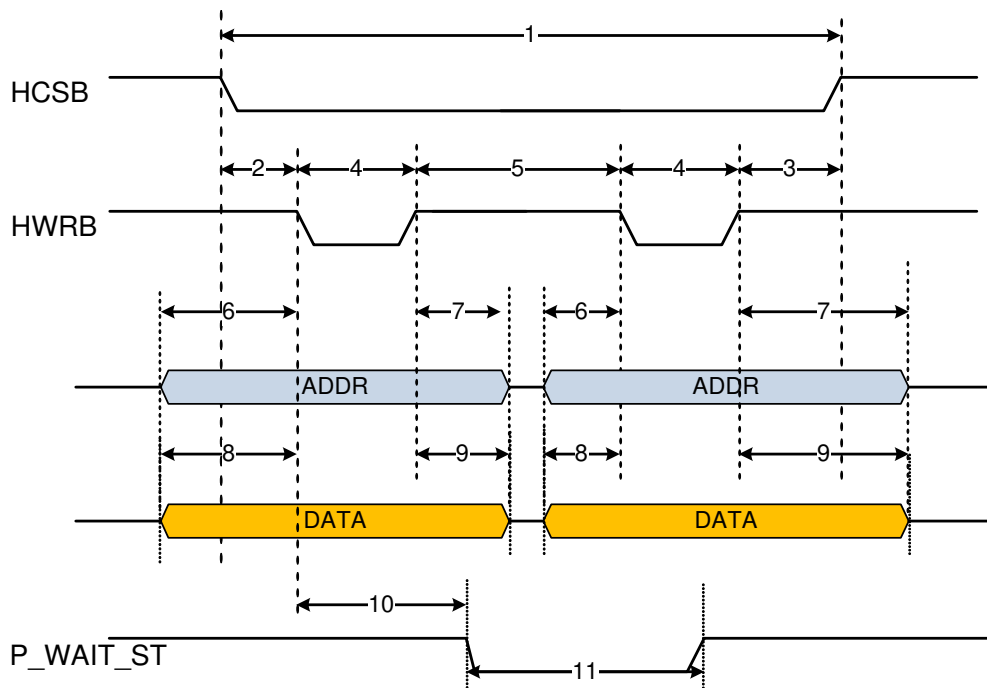

	Parameter	Symbol	Min	Max	Units
1	HCSB pulse width	Tcs	33	N/A	ns
2	HCSB low to HWRB low	Hwrb_tsu	0	N/A	ns
3	HWRB high to HCSB high	Hwrb_th	0	N/A	ns
4	HWRB pulse width	Hwr	33	N/A	ns
5	Spacing between HWRB pulses	Hwr_sp	33	N/A	ns
6	HADDR setup to HWRB low	Haddr_tsu	2	N/A	ns
7	HADDR hold after HWRB high	Haddr_th	0	N/A	ns
8	HDAT write setup to HWRB low	Hdat_wr_tsu	5	N/A	ns
9	HDAT write hold after HWRB high	Hdat_wr_th	0	N/A	ns
10	Write pulse low to wait signal low	Twalt	30	35	ns
11	CPU Halt to TW2880 access	TcpuH	30	-	ns

External Host Interface Connection

As stated in the previous section there are two data width connection methods in TW2880: 8 bit and 16 bit connection. 8 bit connection is rather straight forward, user only needs to tie EN16B to low and connect CPU address [11:0] to HADDR[11:0], CPU data [7:0] to HDAT[7:0] and start accessing but basically treat TW2880 as an 8 bit peripheral.

On the other hand, when high OSG data throughput is needed and user may elect to connect TW2880 as a 16 bit device, In this usage user needs to connect EN16B along with other control signals, connect CPU address [12:1] to HADDR[11:0], CPU data [15:0] to HDAT[15:0]. In this way, the CPU address used to access TW2880 needs to be multiplied by two. For TW2880 registers access, CPU should set EN16B to low, data is to / from HDAT[7:0], upper byte is ignored (except 0x13A). For memory access, CPU needs to set EN16B to high, and data is to / from hdat[15:0]. EN16B timing requirement follows the requirement of HCSB.

External Host to Display Memory access Interface

TW2880 allows the external host get access to the display memory. This feature is provided mainly for debugging purpose because in normal operations user does not need to read or write the content of the DRAM. To use this feature user only need to program the 24 bit linear starting address into the three registers (0x000, 0x001, 0x002), then program the DRAM access control register 0x003 to specify the read or the write operation and the burst length. Once these registers are programmed, for write operations users need to write to port register 0x004 continuously until the number of bytes written equal to the burst length. For read operation user needs to read the port register continuously to get all the data requested.

DMA Interface

The DMA interface in TW2880 is designed to facilitate the high speed transfer of the bitmap and menu data from the host to TW2880. TW2880 DMA interface served as a master when doing DMA transfer. Two asynchronously sampled pin: HDREQ, HDACK and the 16 bit data bus are used.

To start a DMA transaction, user first set the proper timing parameters, transaction length and direction in the DMAC register (page 2). When enable the DMA channel, HDREQ will go active to signaling the host a DMA request is made, DMAC then will wait for HDACK to go active, meaning after some time valid data will appear or we need to supply data to the data bus. After the first transaction is done, TW2880 will need to wait for a while before starting the sequence again.

The burst size we supported can be one or four. Also if setting the total count larger than one, TW2880 can accept multiple data stream into the TW2880. Please also see the "DMAC" chapter for the destination arrangement.

Unit Transfer, Burst Size = 1

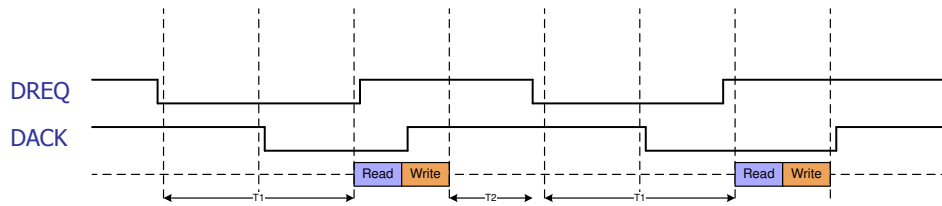

Unit Transfer, Burst Size = 4

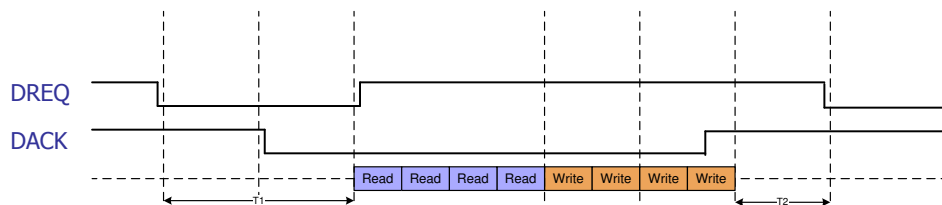

Multiple Transfer, Burst Size = 1

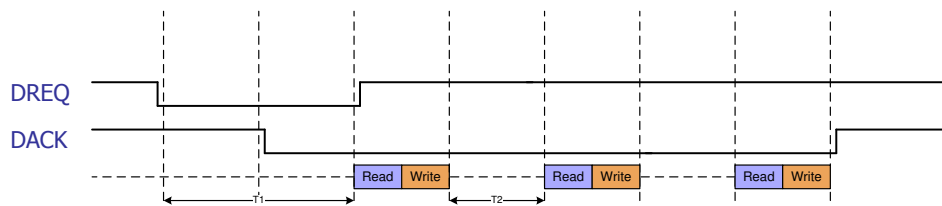

Interrupt Interface

The TW2880 provides a very sophisticated interrupt request function for user to inter-react with the host CPU. Any video loss, motion, blind, or night detection in every channel will generate an interrupt request to the host CPU. The polarity of the interrupt is selectable by the user. The user can disable the one single interrupt function for each channel and category. After receiving the interrupt, the host can distinguish which functional unit generated the interrupt by writing to the interrupt status registers. User can choose to read the real time detection status of the all functional units by changing a bit. The interrupt can be cleared by reading the interrupt clearing registers.

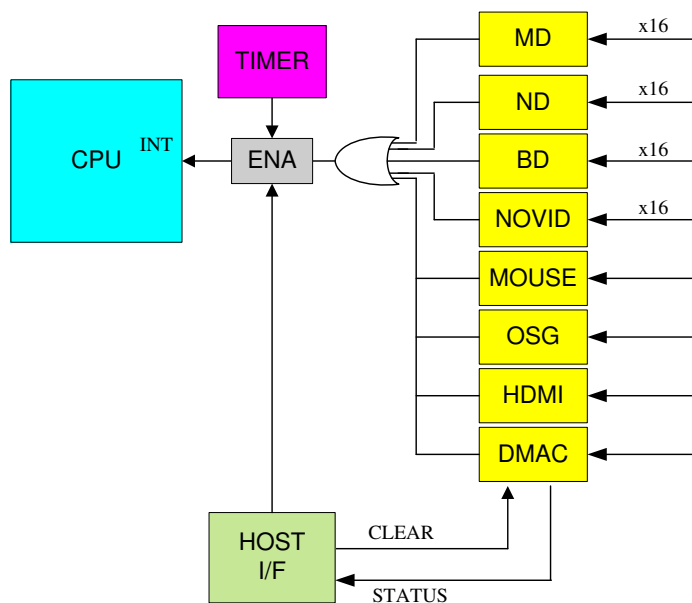

A set of idle and resend counters is incorporated in the interrupt generation process to help easing the burden of the CPU in responding and switching between different interrupt service routines. Once an interrupt is raised and does not get attention of CPU for certain period of time, the interrupt of TW2880 will become inactive for a while and become active again. This process will go on indefinitely until the unit gets reset. This function can be disabled by user.

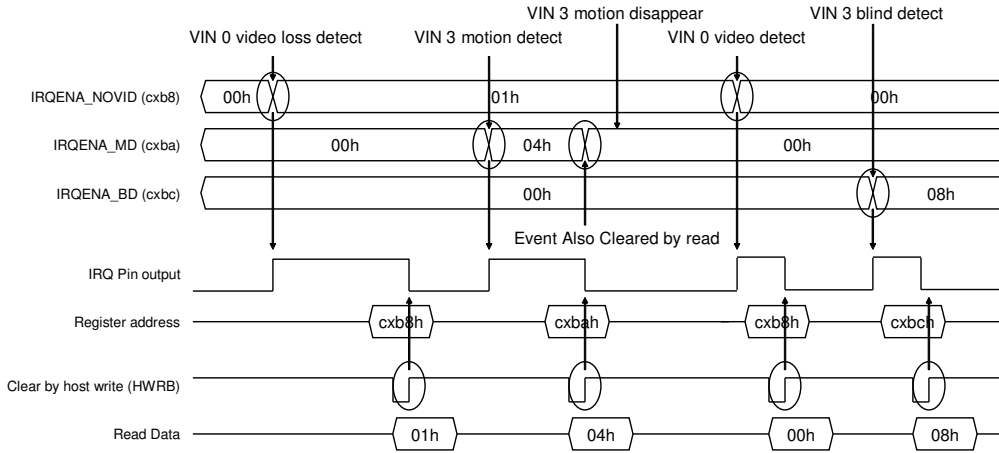

ILLUSTRATION OF THE INTERRUPT GENERATED AND CLEARED SEQUENCE

Register Table

Address	R/W	Default	Description
0xCB0	R/W	0x00	No video IRQ Enable Register 1
0xCB1	R/W	0x00	No video IRQ Enable Register 2
0xCB2	R/W	0x00	Motion Detection IRQ Enable Register 1
0xCB3	R/W	0x00	Motion Detection IRQ Enable Register 2
0xCB4	R/W	0x00	Blind Detection IRQ Enable Register 1
0xCB5	R/W	0x00	Blind Detection IRQ Enable Register 2
0xCB6	R/W	0x00	Night Detection IRQ Enable Register 1
0xCB7	R/W	0x00	Night Detection IRQ Enable Register 2
0xCB8	R/W	0x00	No video IRQ Status Register 1
0xCB9	R/W	0x00	No video IRQ Status Register 2
0xCBA	R/W	0x00	Motion Detection IRQ Status Register 1
0xCBB	R/W	0x00	Motion Detection IRQ Status Register 2
0CBC	R/W	0x00	Blind Detection IRQ Status Register 1
0CBD	R/W	0x00	Blind Detection IRQ Status Register 2
0xCBE	R/W	0x00	Night Detection IRQ Status Register 1
0CBF	R/W	0x00	Night Detection IRQ Status Register 2
0xCC0	R/W	0x00	IRQ Main Control Register
0xCC1	R/W	0x00	IRQ Spacing Register
0xCC2	R/W	0x00	IRQ Report Counter Register 1
0xCC3	R/W	0x00	IRQ Report Counter Register 2
0xCC4	R/W	0x00	IRQ Report Counter Register 3
0xCC6	R/W	0x00	AUX. IRQ Status Register
0xCC7	R/W	0x00	MPOUT Selection Register
0x000	R/W	0x00	Display DRAM Address Register 0
0x001	R/W	0x00	Display DRAM Address Register 1
0x002	R/W	0x00	Display DRAM Address Register 2
0x003	R/W	0x00	Display DRAM Access Control Register
0x004	R/W	0x00	Display DRAM Data Port Register

Registers Description

NO VIDEO IRQ ENABLE REGISTER 1 – 0XCBO

Bit	R/W	Default	Description
7:0	R/W	0	IRQENA_NOVID[7:0] for channel 7:0 1: enable 0: disable

NO VIDEO IRQ ENABLE REGISTER 2 – 0XCB1

Bit	R/W	Default	Description
7:0	R/W	0	IRQENA_NOVID[15:8] for channel 15:8 1: enable 0: disable

MOTION DETECTION IRQ ENABLE REGISTER 1 – 0XCB2

Bit	R/W	Default	Description
7:0	R/W	0	IRQENA_MD[7:0] for channel 7:0 1: enable 0: disable

MOTION DETECTION IRQ ENABLE REGISTER 2 – 0XCB3

Bit	R/W	Default	Description
7:0	R/W	0	IRQENA_MD[15:8] for channel 15:8 1: enable 0: disable

BLIND DETECTION IRQ ENABLE REGISTER 1 – 0XCB4

Bit	R/W	Default	Description
7:0	R/W	0	IRQENA_BD[7:0] for channel 7:0 1: enable 0: disable

BLIND DETECTION IRQ ENABLE REGISTER 2 – 0XCB5

Bit	R/W	Default	Description
7:0	R/W	0	IRQENA_BD[15:8] for channel 15:8 1: enable 0: disable

NIGHT DETECTION IRQ ENABLE REGISTER 1 – 0XCB6

Bit	R/W	Default	Description
7:0	R/W	0	IRQENA_ND[7:0] for channel 7:0 1: enable 0: disable

NIGHT DETECTION IRQ ENABLE REGISTER 2 – 0XCB7

Bit	R/W	Default	Description
7:0	R/W	0	IRQENA_ND[15:8] for channel 15:8 1: enable 0: disable

NO VIDEO IRQ STATUS REGISTER 1 – 0XCBS

Bit	R/W	Default	Description
7:0	R	0	Irq_rd_novid[7:0] for channel 7:0 1: Interrupt 0: idle

NO VIDEO IRQ STATUS REGISTER 2 – 0XCBS9

Bit	R/W	Default	Description
7:0	R	0	Irq_rd_novid[15:8] for channel 15:8 1: interrupt 0: idle

MOTION DETECTION IRQ STATUS REGISTER 1 – 0XCBA

Bit	R/W	Default	Description
7:0	R	0	Irq_rd_md[7:0] for channel 7:0 1: interrupt 0: idle

MOTION DETECTION IRQ STATUS REGISTER 2 – 0XCBB

Bit	R/W	Default	Description
7:0	R	0	Irq_rd_md[15:8] for channel 15:8 1: interrupt 0: idle

BLIND DETECTION IRQ STATUS REGISTER 1 – 0XCBC

Bit	R/W	Default	Description
7:0	R	0	Irq_rd_bd[7:0] for channel 7:0 1: interrupt 0: idle

BLIND DETECTION IRQ STATUS REGISTER 2 – 0XCBD

Bit	R/W	Default	Description
7:0	R	0	Irq_rd_bd[15:8] for channel 15:8 1: interrupt 0: idle

NIGHT DETECTION IRQ STATUS REGISTER 1 – 0XCBE

Bit	R/W	Default	Description
7:0	R	0	Irq_rd_nd[7:0] for channel 7:0 1: interrupt 0: idle

NIGHT DETECTION IRQ STATUS REGISTER 2 – 0XCBF

Bit	R/W	Default	Description
7:0	R	0	Irq_rd_nd[15:8] for channel 15:8 1: interrupt 0: idle

IRQ MAIN CONTROL REGISTER –OFFSET 0XCC0

Bit	R/W	Default	Description
7	R/W	0	IRQENA_RD_MD 0 = normal 1 = When read interrupt status line become interrupt enable line
6	R/W	0	Interrupt Polarity Select 0 positive 1 negative
5	R/W	0	Main Interrupt line enable 0 no report 1 report
4:0	R/W	0	Control Line Select for reserved, nd, bd, md, novid 0 real detect 1 irq register

IRQ SPACING REGISTER – 0XCC1

Bit	R/W	Default	Description
7:0	R/W	0	Irq period[7:0]

IRQ REPORT COUNTER REGISTER 1 – 0XCC2

Bit	R/W	Default	Description
7:0	R/W	0x0	IRQ Report Counter[7:0]

IRQ REPORT COUNTER REGISTER 2 – 0XCC3

Bit	R/W	Default	Description
7:0	R/W	0x0	IRQ Report Counter[15:8]

IRQ REPORT COUNTER REGISTER 3 – 0XCC4

Bit	R/W	Default	Description
7:4	R/W	0x0	Reserved
3:0	R/W	0x0	IRQ Report Counter[19:16]

AUX. IRQ STATUS REGISTER –OFFSET 0XCC6

Bit	R/W	Default	Description
7	R	0	Reserved
6	R	0	DMAC Interrupt Status 0: idle 1: active
5	R	0	HDMI Interrupt Status 0: idle 1: active
4	R	0	OSG1 Interrupt Status 0: idle 1: active
3	R	0	OSG2 Interrupt Status 0: idle 1: active
2	R	0	OSG3 Interrupt Status 0: idle 1: active
1	R	0	MOUSE Interrupt Status 0: idle 1: active
0	R	0	I²C Master Interrupt Status 0: idle 1: active

MPOUT SELECTION REGISTER —OFFSET 0XCC7

Bit	R/W	Default	Description
7	R/W	0	Reserved
6:4			Port Select 111: Select port8 110: Select port7 101: Select port6 100: Select port5 011: Select port4 010: Select port3 001: Select port2 000: Select port1
3:0	R/W	0	Select Essential Output Sync. Pulse for User 1111: Select reserved 1110: Select reserved 1101: Select VIS_VOS 1100: Select VIS_HOS 1011: Select VIS_FOS 1010: Select even_rosd 1001: Select fld_rosd 1000: Select vblank_rosd 0111: Select hblank_rosd 0110: Select FLD_MODE 0101: Select even_toggle 0100: Select even 0011: Select fm_even 0010: Select ft_even 0001: Select hblank 0000: Select vblank

DISPLAY DRAM ADDRESS REGISTER 0 – 0X000

Bit	R/W	Default	Description
7:0	R/W	0	Display Memory Address Lo Byte of the tress byte address

DISPLAY DRAM ADDRESS REGISTER 1– 0X001

Bit	R/W	Default	Description
7:0	R/W	0	Display Memory Address Mid Byte of the tress byte address

DISPLAY DRAM ADDRESS REGISTER 2– 0X002

Bit	R/W	Default	Description
7:0	R/W	0	Display Memory Address High Byte of the tress byte address

DISPLAY DRAM ACCESS CONTROL REGISTER —OFFSET 0X003

Bit	R/W	Default	Description
7:6	R/W	0	Display DRAM read / write enable 00 = Reserved 01 = Enable read access 10 = Reserved 11 = Enable write access
5:0	R/W	0	Burst Width Numbers of bytes to be written or read from memory

DISPLAY DRAM DATA PORT REGISTER— 0X004

Bit	R/W	Default	Description
7:0	R/W	0	Display Memory Data[7:0]

Clock Synthesizer and Pin MUX

Introduction

TW2880 has an integrated PLL system to generate all the clocks that are needed. Follow the block diagram, a 27 MHz crystal is the only external component that are needed. The crystal and the on-chip oscillator supply the base frequency to the on-chip PLL system. The base frequency is fed into three PLLs: One for generating a fixed system clock at 108 MHz, one for generating display clock for the display unit and is changeable. The last PLL is used for supplying memory clock to the outside SDRAM and is also changeable.

Clock Synthesizer Circuit

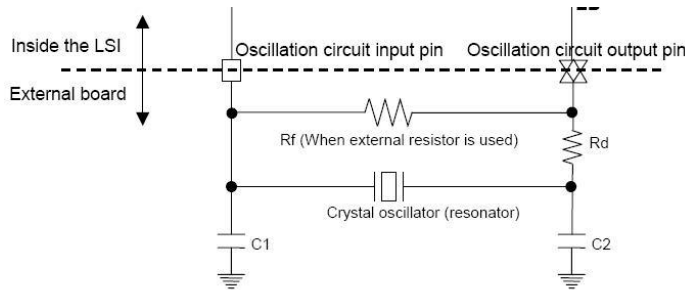

Symbol	Explanation
C1, C2	External load capacitance
Rf	Feedback resistor
Rd	Dumping resistor (only when necessary)

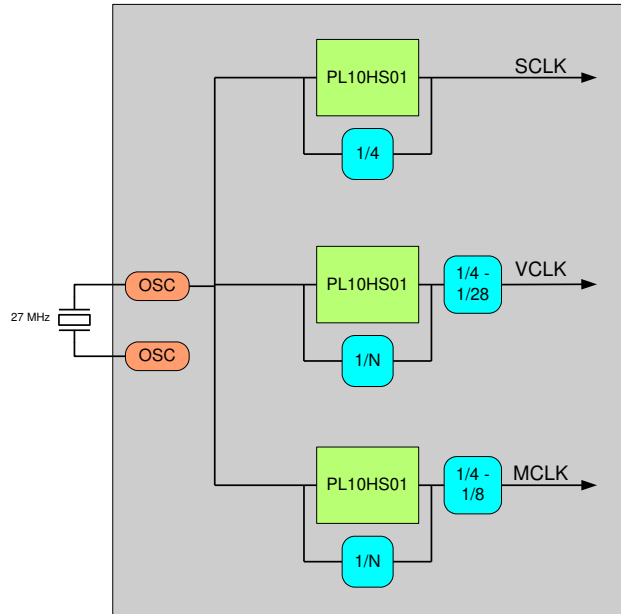

Frequency	C1, C2 (pf)	Rf (Mohm)	Rd (ohm)	Order
27 MHz	10	1	470	Fundamental

	Freq	Tolerance @25°C	Stability @25°C	Duty Cycle	Remark
OSC	27 MHz	±50 ppm	±50 ppm	55%	

Output Clock Summary

From	Frequency	Duty cycle	Jitter	Skew (from rising edge of reference clock)	Remark
SCLK	108 MHz	50%	250ps	1000ps	
VCLK	25 MHz	50%	250ps	1000ps	D=16 N=Eh
	108 MHz	50%	250ps	1000ps	D=04 N=Fh
	126 MHz	50%	250ps	1000ps	D=06 N=1Bh
	148.5 MHz	50%	250ps	1000ps	D=08 N=2Bh
MCLK	198.5 MHz	50%	250ps	1000ps	D=06 N=2Bh
	184.5 MHz	50%	250ps	1000ps	D=06 N=28h
	166.5 MHz	50%	250ps	1000ps	D=06 N=24h
	144 MHz	50%	250ps	1000ps	D=06 N=1Fh
	135 MHz	50%	250ps	1000ps	D=06 N=1Dh

Power On Sequence

There are six power rails in TW2880, Core 1.2V, PLL 1.2V, I/O 3.3V, DAC 3.3V, Vref 1.1v, HDMI 3.3V. The recommended power sequence is showed in the following drawing:

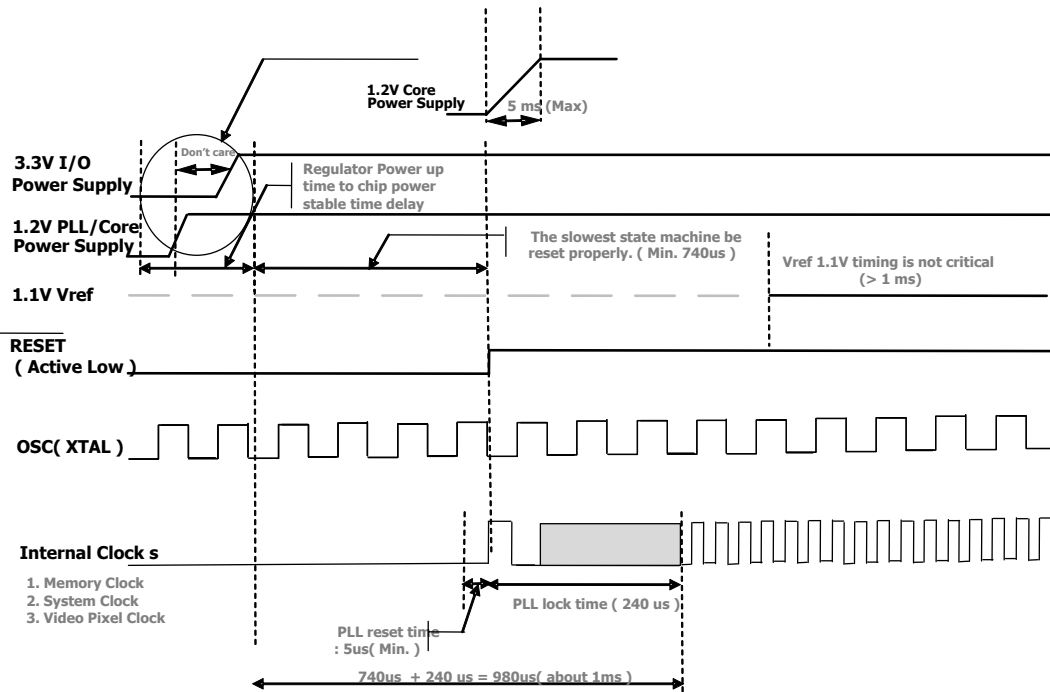

The power to the crystal circuit needs to be turned on first followed by the power to 1.2V core supply rail.

Then it is followed by the 3.3V I/O power to the TW2880. However, 3.3V I/O power can be turned on first

as long as the 1.2V core power rail is also turned on within 100 mS. The master reset signal needs to last at least 740 μ s to truly reset internal PLL circuitry. After master reset signal, TW2880 will generate many internal reset signals to reset the chip using the stable clocks. The 1.1V DAC reference voltage has a direct impact on the video quality of the output image so it has to either come from a voltage reference chip or from a well designed CCS circuit. Please see the example on the EVB. The TW2880 has to follow certain power off sequence to guarantee working 3.3V I/O power should be turned off first, then the 1.2V core and PLL power rail should be turned off.

Live Video Pin Mux

TW2880's live video port have other definition when running at 108 MHz mode. Please refer to control register 0x201 bit 2. When this bit equal to 0, the inputs are used for live video channel running at 54 MHz. When this bit equal to 1, the port 5. 6. 7. 8 are defined as output pins and is used to output digital R, G, B of the main display. But if this bit equals to 1 and the external OSD option is selected, this extra pins are used as input pin to accept OSD data from an external chip in master mode. See the following chart as reference.

	0x201 Bit [2] = 0	0x201 Bit [2] = 1	
INPUT	LV clock12	LV clock12	
IN1	BT656[7:0]	BT656[7:0]	
IN2	BT656[7:0]	BT656[7:0]	
INPUT	LV clock34	LV clock34	

IN3	BT656[7:0]	BT656[7:0]	
IN4	BT656[7:0]	BT656[7:0]	
IN/OUT	LV clock56	VCLK out	Pixel clock
IN/OUT 5	BT656[7:0]	R[7:0]	
IN/OUT 6	BT656[7:0]	G[7:0]	
IN/OUT	LV clock78	DEN / SWITCH	Display enable
IN/OUT 7	BT656[7:0]	B[7:0]	
IN/OUT 8	BT656[7:0]		

Port 80 Display

Port 80 display subsystem is a very handy tool in debugging and diagnostic the TW2880-based system. User can access to port 80 display registers by the normal CPU read / write. Together with this capability and the on board 7-segment decoder and LDE, use can “print out” 2 or 4 digits of alphanumeric code and read it. This is the exact equivalent of the 2 hex digit LED display system normally seen in an PC where each booting step is displayed through the LED. This is useful to determine how far the system boot process goes if you have a system hang and can also be served as a process indicator when the system is running normally. A two digit or four digit systems option is supported.

User can choose lit up the two decimals to further classify the booting code or communication message as one big category and several small categories.

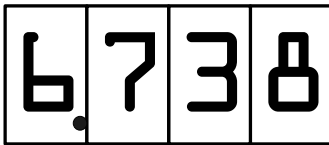
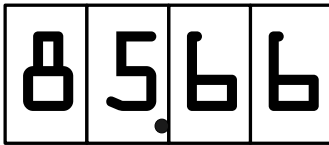

HDMI Transmitter Signal Adjustment

TW2880's HDMI transmitter support four output modes to fit different situation. It is listed in the below table.

IODCNT[2:0]	IOPCNT[2:0]	DRVCNT	OUTPUT MODE
101	011	1	A: Normal
110	000	1	B: Lower Amplitude
110	010	0	C: Medium De-Emphasis
101	011	0	D: Deep De-Emphasis

The major difference between the four output modes are in the voltage swing. It is tabulated in Table 26.

TABLE 26. SWING CONTROL

Symbol	Parameter	Conditions	mode	Min	Typ	Max	Unit
Vod	Differential Outputs single ended swing amplitude (Emphasis bit)	Rload=50ohm	A,C,D		500		mV
			B		250		mV
Vod-de	Differential Outputs single ended swing amplitude (De-Emphasis bit)	Rload=50ohm	A		500		mV
			C		350		mV
			B,D		250		mV
De-Ratio	De-Emphasis ratio	Rload=50ohm	A,B		0		dB
			C		3		dB
			D		6		dB

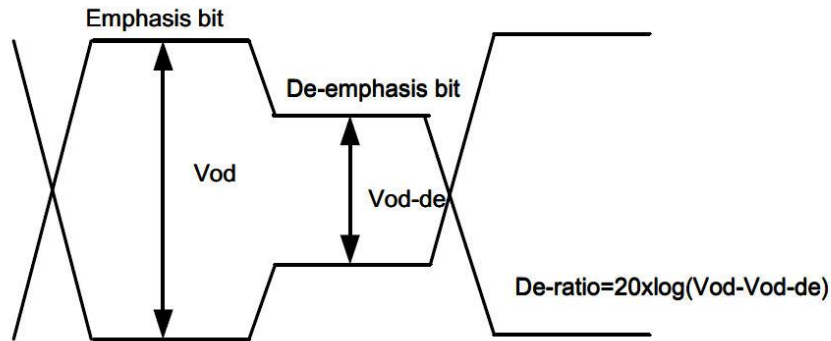

FIGURE 25. DE-EMPHASIS RATIO

Figure 25 shows the De-emphasis function. In this chart, the Emphasis bit means the first bit of the series of same value bits. The Emphasis bit has full swing amplitude (see “Vod” in Table 26). The De-emphasis bit follows the Emphasis bit. The De-emphasis ratio/amplitude can be changed as described in “Vod-de” and “De-Ratio” in Table 26.

Register Table

Address	R/W	Default	Description
0x200	R/W	0x00	Reserved
0x201	R/W	0x00	MISC. Control Register
0x202	R/W	0x00	MPLL M Duty Cycle Control Register (MPLLMR)
0x203	R/W	0x00	MPLL N Multiplier Factor Register (MPLLNR)
0x204	R/W	0x00	NPLL M Duty Cycle Control Register (NPLLMR)
0x205	R/W	0x00	NPLL N Multiplier Factor Register (NPLLNR)
0x206	R/W	0x00	SPLL M Duty Cycle Control Register (SPLLMR)
0x207	R/W	0x00	SPLL N Multiplier Factor Register (SPLLNR)
0x208	R/W	0x00	MCLK PLL Divider Control Register 1
0x209	R/W	0x00	VCLK PLL Divider Control Register 1
0x20A	R/W	0x00	IN Rate Select Register
0x20B	R/W	0x00	Digital Block Reset Control Register 1
0x20C	R/W	0x00	Digital Block Reset Control Register 2
0x20D	R/W	0x00	Digital Block Reset Control Register 3
0x20E	R/W	0x00	Digital Block Reset Control Register 4
0x20F	R/W	0x00	Digital Block Reset Control Register 5
0x210	R/W	0x00	LCD Display Pitch Register
0x211	R/W	0x00	Display DRAM Controller Configuration Register
0x212	R/W	0x00	Recording DRAM Controller Configuration Register
0x213	R/W	0x00	Port 80 Control Register
0x214	R/W	0x00	Port 80 Content Register 1
0x215	R/W	0x00	Port 80 Content Register 2
0x216	R/W	0x00	SPLL Phase Control Register 1
0x217	R/W	0x00	PLL Soft Reset Control Register
0x218	R/W	0x00	REC Output Clock Phase Control Register 1
0x219	R/W	0x00	REC Output Clock Phase Control Register 2
0x21A	R/W	0x00	TV Decoder Output Clock Select Register
0x21B	R/W	0x00	HDMI physical Interface Control Register
0x21C	R/W	0x00	Live Input Clock Phase Select Register
0x21D	R/W	0x00	DRAM Space Access Select Register
0x21E	R/W	0x00	Network Port Data Source Select Register
0x21F	R/W	0x00	SCLK Phase Control Register 2
0x220	R/W	0x00	MCLK Phase Control Register
0x221	R/W	0x00	VCLK PLL Divider Control Register 2
0x222	R/W	0x00	VCLK PLL Divider Control Register 3
0x223	R/W	0x00	VCLK PLL Divider Control Register 4
0x224	R/W	0x48	LP_CON1 x Control Register
0x225	R/W	0x5a	LP_CON2 x Control Register
0x226	R/W	0x6c	LP_CON3 x Control Register
0x227	R/W	0x7e	LP_CON4 x Control Register
0x228	R/W	0x00	Audio Control 1 Register
0x229	R/W	0x00	Audio Control 2 Register
0x22C	R/W	0x00	CPU Fast Access Control Register
0x22D	R/W	0x00	CPU Freeze Display Pitch Register
0x22E	R/W	0x00	SCLK Phase Control Register 3
0x26D	R/W	0x00	DRAM Address Mapping Register
0x270	R/W	0x00	Chip ID Register
0x280	R/W	0x00	Display DRAM Priority Arbitration Register 1
0x281	R/W	0x00	Display DRAM Priority Arbitration Register 2
0x282	R/W	0x00	Display DRAM Priority Arbitration Register 3
0x284	R/W	0x03	Record DRAM Priority Arbitration Register 1

Address	R/W	Default	Description
0x285	R/W	0x00	Record DRAM Priority Arbitration Register 2
0x286	R/W	0x00	Record DRAM Priority Arbitration Register 3

Registers Description

AUDIO CONTROL REGISTER —OFFSET 0X200

Bit	R/W	Default	Description
7:0	R	0	Reserved

MISC. CONTROL REGISTER —OFFSET 0X201

Bit	R/W	Default	Description
7	R/W	0	Digital Output Select 0: select main 1: select dual monitor
6	R	0	Reserved
5	R/W	0	External_CLKIN enable 0: no external clock in 1: external clock in for BT.1120 mode
4	R/W	0	OSG output clock enable 0: No external OSG clock output 1: external OSG clock output through din8[1] port
3	R/W	0	REC_ENC_OEN 0: REC output enable 1: REC output off
2	R/W	0	External_RGB24_OEN 0: Vin port 5,6,7 is set as inputs 1: RGB24 output enable control, MP_out as clock source
1	R/W	0	Reserved
0	R/W	0	LCD display power down 0: Enable analog VGA display 1: VGA display power off

MPLL M DUTY CYCLE CONTROL REGISTER (MPLL MR) —OFFSET 0X202

Bit	R/W	Default	Description
7:6	R/W	0	Reserve
5:0	R/W	0x0d	MPLL M factor MPLL FB duty control

MPLL N MULTIPLIER FACTOR REGISTER (MPLL NR) —OFFSET 0X203

Bit	R/W	Default	Description
7:6	R/W	0	Reserve
5:0	R/W	0x24 166.6MHz	MPLL N factor MPLL multiply factor. Mclk = 27MHz * (N+1) / Mclk_DivQ

VPLL M DUTY CYCLE CONTROL REGISTER (VPLLMR) —OFFSET 0X204

Bit	R/W	Default	Description
7:6	R/W	0	Reserve
5:0	R/W	0x0d	VPLL M factor VPLL FB duty control

VPLL N MULTIPLIER FACTOR REGISTER (VPLLNR) —OFFSET 0X205

Bit	R/W	Default	Description
7:6	R/W	0	Reserve
5:0	R/W	0x27 108MHz	VPLL N factor VPLL multiply factor. Vclk = 27MHz * (N+1) / Vclk_DivQ

SPLL M DUTY CYCLE CONTROL REGISTER (SPLLMR) —OFFSET 0X206

Bit	R/W	Default	Description
7:6	R/W	0	Reserve
5:0	R/W	0x0f	SPLL M factor SPLL feedback duty control, can be set to 0

SPLL N MULTIPLY FACTOR REGISTER (SPLLNR) —OFFSET 0X207

Bit	R/W	Default	Description
7:6	R/W	0	Reserve
5:0	R/W	0x1f	SPLL N factor SPLL multiply factor. sclk = 27MHz * (N+1) / 8. When normal operation, don't change this register.

MCLK PLL DIVIDER CONTROL REGISTER 1 —OFFSET 0X208 (UPPER BYTE AT 0X220)

Bit	R/W	Default	Description
7:6	R/W	0	Reserve
5	R/W	0	REC Port DRAM Clk Invert control 0 : not invert 1 : invert
4	R/W	0	LCD Display DRAM Clk Invert control 0 : not invert 1 : invert
3:1	R/W	0	Internal Mclk Divide Control 100 : Mclk_divQ equals 8 010 : Mclk_divQ equals 7 001 : Mclk_divQ equals 6 000 : Mclk_divQ equals 4
0	R/W	0	Mclk phase Control 1 : invert 0 : not invert

VCLK PLL DIVIDER CONTROL REGISTER 1—OFFSET 0X209 (UPPER BYTE AT X221 .. X223)

Bit	R/W	Default	Description
7:5	R/W	3'h4	Internal Rclk Divide Control 3'h7 : Vclk_divQ equals 16 3'h6 : Vclk_divQ equals 28 3'h5 : Vclk_divQ equals 12 3'h4 : Vclk_divQ equals 10 3'h3 : Vclk_divQ equals 8 3'h2 : Vclk_divQ equals 7 3'h1 : Vclk_divQ equals 6 3'h0 : V_divQ equal 4
4	R/W	0	Rclk phase control 1 : invert 0 : not invert
3:1	R/W	3'h4	Internal Vclock Divide Control 3'h7 : Vclk_divQ equals 16 3'h6 : Vclk_divQ equals 28 3'h5 : Vclk_divQ equals 12 3'h4 : Vclk_divQ equals 10 3'h3 : Vclk_divQ equals 8 3'h2 : Vclk_divQ equals 7 3'h1 : Vclk_divQ equals 6 3'h0 : Vclk_divQ equals 4
0	R/W	0	Vclk phase control 1 : invert 0 : not invert

IN RATE SELECT REGISTER —OFFSET 0X20A

Bit	R/W	Default	Description
7:2	-	-	Reserved
1:0	R/W	0	Input data frequency selection 00: live video input is set to 108 MHz 01: live video input is set to 54 MHz 1X: Live video input is set at 27 MHz

DIGITAL BLOCK RESET CONTROL REGISTER 1—OFFSET 0X20B

Bit	R/W	Default	Description
7:2	R	01	Reserved
1	R/W	0	Soft Reset Control RGB controller 0: normal operation 1: reset RGB controller
0	R/W	0	Soft Reset Control PB in RGB interface controller 0: normal operation 1: reset PB controller

DIGITAL BLOCK RESET CONTROL REGISTER 2 —OFFSET 0X20C

Bit	R/W	Default	Description
7:5	-	-	Reserved
4	R/W	0	Soft Reset OSGW controller 0: normal operation 1: reset OSGW controller
3	R/W	0	Soft Reset OSG controller 0: normal operation 1: reset OSG controller
2	R/W	0	Soft Reset 2D/3D de-interlace controller 0: normal operation 1: reset 2D/3D de-interlace controller
1	R/W	0	Soft Reset LCD DRAM controller 0: normal operation 1: reset LCD DRAM controller
0	R/W	0	Soft Reset the whole LCD controller 0: normal operation 1: reset LCD controller

DIGITAL BLOCK RESET CONTROL REGISTER 3 —OFFSET 0X20D

Bit	R/W	Default	Description
7	R/W	0	Soft Reset OSG BITMAP controller 0 normal operation 1 reset osg BITMAP controller
6	R/W	0	Soft Reset OSG DMA controller 0 normal operation 1 reset osg DMA controller
5	R/W	0	Soft Reset Freeze DMA controller 0 normal operation 1 reset freeze DMA controller
4	R/W	0	Soft Reset I²C master controller 0 normal operation 1 reset I ² C master controller
3	R/W	0	Soft Reset the SPOT controller SCLK domain 0 normal operation 1 reset spot ck108 control modules
2	R/W	0	Soft Reset the SPOT controller MCLK domain 0: normal operation 1: reset spot mclk domain logic
1	R/W	0	Soft Reset the Dual Monitor controller SCLK domain 0 normal operation 1 reset dual monitor ck108 control modules
0	R/W	0	Soft Reset the Dual Monitor controller MCLK domain

Bit	R/W	Default	Description
			0: normal operation 1: reset dual monitor mclk domain logic

DIGITAL BLOCK RESET CONTROL REGISTER 4 –OFFSET 0X20E

Bit	R/W	Default	Description
7:4	R	0	Reserved
3	R/W	0	Soft Reset IRQ controller 0 normal operation 1 reset control modules
2	R/W	0	Soft Reset MD controller MCLK & SCLK domain 0 normal operation 1 reset ENC MCLK & SCLK control modules
1	R/W	0	Soft Reset Encoder controller in SCLK, VCLK, MCLK domain 0 normal operation 1 reset modules
0	R/W	0	Soft Reset Decoder controller SCLK, VCLK, MCLK domain 0 normal operation 1 reset modules

DIGITAL BLOCK RESET CONTROL REGISTER 5 –OFFSET 0X20F

Bit	R/W	Default	Description
7	-	-	Reserved
6	R/W	0	Soft Reset Host to Memory controller 0 normal operation 1 reset Host to Memory controller
5	R/W	0	Soft Reset DCU2 controller 0 normal operation 1 reset DCU2 controller
4	R/W	0	Soft Reset DCU controller 0 normal operation 1 reset DCU controller
3	R/W	0	Soft Reset Down Scaler controller SCLK domains 0 normal operation 1 reset Down Scaler in sck control modules
2	R/W	0	Soft Reset Down Scaler controller PB channels 0 normal operation 1 reset Down Scaler in PBCLK control modules
1	R/W	0	Soft Reset Down Scaler controller CK27VIN domains 0 normal operation 1 reset Down Scaler in CK27VIN control modules
0	R/W	0	Soft Reset the Down Scaler controller 0 normal operation 1 reset all Down Scaler controllers

LCD DISPLAY PITCH REGISTER – OFFSET 0X210

Bit	R/W	Default	Description
7:0	R/W	0x80	Horizontal Display Pitch for LCD This is SDRAM logic horizontal size. The unit is 16 pixels / 32 bytes. Default is 2048/16=128. If 2x128Mbit SDRAM, one page SDRAM can be mapped to 2048x2048 pixels logic size. There are four pages in one SDRAM.

DISPLAY DRAM CONTROLLER CONFIGURATION REGISTER – 0X211

Bit	R/W	Default	Description
7	R	0	Reserved
6	R/W	0	1 = Extra pre-charge cycle (default 0)
5	R/W	0	1 = Disable refresh
4	R/W	0	Refresh speed select 1 = fast speed 0 = Slow speed
3	R/W	0	0 = Extra RAS2CAS cycle (default 0)
2:1	R/W	1	DRAM Type Select 00 = 64 Mbit 01 = 128 Mbit 10 = 256 Mbit 11 = Reserved
0	R/W	1	DRAM Data Width Select 0 = 32 bit, 1 = 64 bit (default)

RECORDING DRAM CONTROLLER CONFIGURATION REGISTER – 0X212

Bit	R/W	Default	Description
7	R	0	Reserved
6	R/W	0	1 = Extra pre-charge cycle (default 0)
5	R/W	0	1 = Disable refresh
4	R/W	0	Refresh speed select 1 = fast speed 0 = Slow speed
3	R/W	0	0 = Extra RAS2CAS cycle (default 0)
2:1	R/W	1	DRAM Type Select

Bit	R/W	Default	Description
			00 = 64 Mbit 01 = 128 Mbit 10 = 256 Mbit 11 = Reserved
0	R/W	1	DRAM Data Width Select 0 = 32 bit, 1 = 64 bit (default)

PORT 80 CONTROL REGISTER – 0X213

Bit	R/W	Default	Description
7	R/W	0	Port 80 function control 1 = enable 0 = disable
6	R/W	0	Port 80 digit select 0 = output two digit to port 80 (default) 1 = output four digit to port 80
5-4	R	0	Reserved
3	R/W	0	Digit 3 Decimal Control, 1 = enable
2	R/W	0	Digit 2 Decimal Control, 1 = enable
1	R/W	0	Digit 1 Decimal Control, 1 = enable
0	R/W	0	Digit 0 Decimal Control, 1 = enable

PORT 80 CONTENT REGISTER 1 – 0X214

Bit	R/W	Default	Description
7:4	R/W	0	Port 80 digit 1
3:0	R/W	0	Port 80 digit 0

PORT 80 CONTENT REGISTER 2 – 0X215

Bit	R/W	Default	Description
7:4	R/W	0	Port 80 digit 3
3:0	R/W	0	Port 80 digit 2

SPLL PHASE CONTROL REGISTER I —OFFSET 0X216

Bit	R/W	Default	Description
7	R/W	0	DM_ENC_CLK clock phase select 1: Invert the DM_ENC_CLK 0: Normal
6	R/W	0	DM_VCLK clock phase select 1: Invert the DM_VCLK 0: Normal
5	R/W	0	DM_FCLK clock phase select 1: Invert the DM_FCLK 0: Normal
4	R/W	0	Select the 27 MHz CLK Phase 1: Invert the 27 MHz CLK 0: Normal
3	R/W	0	Select the 54 MHz CLK Phase 1: Invert the 54 MHz CLK 0: Normal
2	R/W	0	Select 108 MHz phase 1: Invert the 108 MHz 0: Normal
1:0	R/W	0	Select 108 MHz phase control 11: 270° phase shift 10: 180° phase shift 01: 90° phase shift 00: Normal

PLL SOFT RESET CONTROL REGISTER —OFFSET 0X217

Bit	R/W	Default	Description
7	R/W	0	reserve
6	R/W	0	Soft reset port80 in ck108 domain
5	R/W	0	Soft reset extclk
4	R/W	0	Soft reset HDMI in vclk domain
3	R/W	0	Soft reset audio in mclk domain
2	R/W	0	Soft reset VCK PLL
1	R/W	0	Soft reset MCK PLL
0	R/W	0	Soft reset SCK PLL

REC OUTPUT CLOCK PHASE CONTROL REGISTER 1 —OFFSET 0X218

Bit	R/W	Default	Description
7:6	R/W	0	REC1_CLKP_SEL 11: Select inverted DM_VCLK 10: Select Normal DM_VCLK 0X: Select CLK defined by P_CON1 register
5:3	R/W	0	Select DM_VCLK phase as the rec1_clkp, rec3_clkp source 111: 315 degree phase shift

Bit	R/W	Default	Description
			110: 270 degree phase shift 101: 225 degree phase shift 100: 180 degree phase shift 011: 135 degree phase shift 010: 90 degree phase shift 001: 45 degree phase shift 000: No degree phase shift
2:0	R/W	0	Select rclk phase when vclk is the rclk source 111: 315 degree phase shift 110: 270 degree phase shift 101: 225 degree phase shift 100: 180 degree phase shift 011: 135 degree phase shift 010: 90 degree phase shift 001: 45 degree phase shift 000: No degree phase shift

REC OUTPUT CLOCK PHASE CONTROL REGISTER 2 —OFFSET 0X219

Bit	R/W	Default	Description
7:6	R/W	0	Rec4_clkn , Rec4_clkp phase control 11: 270 degree phase shift 10: 180 degree phase shift 01: 90 degree phase shift 00: No phase shift
5:4		0	Rec3_clkn, Rec3_clkp phase control 11: 270 degree phase shift 10: 180 degree phase shift 01: 90 degree phase shift 00: No phase shift
3:2	R/W	0	Rec2_clkn, Rec2_clkp phase control 11: 270 degree phase shift 10: 180 degree phase shift 01: 90 degree phase shift 00: No phase shift
1:0	R/W	0	Rec1_clkn, Rec1_clkp phase control 11: 270 degree phase shift 10: 180 degree phase shift 01: 90 degree phase shift 00: No phase shift

TV DECODER OUTPUT CLOCK SELECT REGISTER —OFFSET 0X21A

Bit	R/W	Default	Description
7:5	R/W	0	REC3_CLKP_SEL 11: Select inverted DM_VCLK 10: Select Normal DM_VCLK 0x: Select CLK defined by P_CON1_reg
4	R/W	0	HIFREQ_CLK_SEL2 1: Select VPLL Hi_freq_clk as the delay control clk for REC

Bit	R/W	Default	Description
			0: Select SPLL Hi_freq_clk as the delay control clk for REC
3	R/W	0	HIFREQ_CLK_SEL1 1: Select VPLL Hi_freq_clk as the delay control clk for RCLK 0: Select SPLL Hi_freq_clk as the delay control clk for RCLK
2:1	R/W	0	HDMI_CLK_SEL 11: Select Inverted DM_VCLK 10: Select Normal DM_VCLK 0x: Select Normal VCLK
0	R/W	0	Select TV decoder clock frequency 1: 54 MHz clock is sent to TV decoder 0: 108 MHz clock is sent to TV decoder

HDMI PHYSICAL INTERFACE CONTROL REGISTER —OFFSET 0X21B

Bit	R/W	Default	Description
7		0	Reserve
6:4	R/W	101	IODCNT Output Current Control 111: Max 000: Min
3:1	R/W	011	IOPCNT De-Emphasis Control 111: Max 000: Min
0	R/W	1	IDRVCNT De-Emphasis Disable 1: De-Emphasis Disable 0: De-Emphasis Enable

LIVE INPUT CLOCK PHASE SELECT REGISTER —OFFSET 0X21C

Bit	R/W	Default	Description
7	R/W	0	CK27PB4 input phase Select 1: Inverts the input clock phase 0: Normal, no phase invert
6	R/W	0	CK27PB3 input phase Select 1: Inverts the input clock phase 0: Normal, no phase invert
5	R/W	0	CK27PB2 input phase Select 1: Inverts the input clock phase 0: Normal, no phase invert
4	R/W	0	CK27PB1 input phase Select 1: Inverts the input clock phase 0: Normal, no phase invert
3	R/W	0	CKVin78 input phase Select 1: Inverts the input clock phase 0: Normal, no phase invert
2	R/W	0	CKVin56 input phase Select

Bit	R/W	Default	Description
			1: Inverts the input clock phase 0: Normal, no phase invert
1	R/W	0	CKVin34 input phase Select 1: Inverts the input clock phase 0: Normal, no phase invert
0	R/W	0	CKVin12 input phase Select 1: Inverts the input clock phase 0: Normal, no phase invert

DRAM SPACE ACCESS SELECT REGISTER —OFFSET 0X21D

Bit	R/W	Default	Description
7:1	R/W	0	Reserve
0	R/W	0	Select DRAM space access from host 1: Host access REC DRAM space 0: Host access LCD DRAM space

NETWORK PORT DATA SOURCE SELECT REGISTER —OFFSET 0X21E

Bit	R/W	Default	Description
7	R/W	0	Select HDMI TX source 1: from Dual display 0: from Main display
6:4	R/W	0	REC2NetWork Port data Source 111: rec8_data 110: rec7_data 111: rec6_data 110: rec5_data 011: rec4_data 010: rec3_data 001: rec2_data 000: rec1_data
3	0	0	Reserved
2	R/W	0	Rec4_by601_H,V,F mux 1: rec4_by601_H4 as the mclk_pll locked output rec4_by601_V4 as the vclk_pll locked output rec4_by601_F4 as the sclk_pll locked output 0: if P80_CON1[7] is 1 rec4_by601_H4 as the port80_out output rec4_by601_V4 as the port80_clko output rec4_by601_F4 as the port80_en output if P80_CON1[7] is 0, normal H, V, F output
1:0	R/W	0	Select Network port data source 11: REC2NetWork 10: DM_vdout 01: SPOT_vdout 00: NET_ENC_DATA

SCLK PHASE CONTROL REGISTER 2 –OFFSET 0X21F

Bit	R/W	Default	Description
7	R/W	0	DM_VCLK_EXT clock phase select 1: Inverts the DM_VCLK_EXT 0: Normal
6:5	R/W	0	DM_FCLK select when SCLK is the clock source 11: 108 MHz 10: 54 MHz 01: 27 MHz 00: 13.5 MHz
4:3	R/W	0	DM_VCLK select when SCLK is the clock source 11: 108 MHz 10: 54 MHz 01: 27 MHz 00: 13.5 MHz
2	R/W	0	DM_VCLK clock source select 1: DM_VCLK is derived from VCLK 0: DM_VCLK is derived from SCLK
1	R/W	0	DM_FCLK clock source select 1: DM_FCLK is derived from VCLK 0: DM_FCLK is derived from SCLK
0	R/W	0	DM_DAC_CLK Phase Select 1: Inverts the DM_DAC_CLK 0: Normal

MCLK PHASE CONTROL REGISTER 2 –OFFSET 0X220

Bit	R/W	Default	Description
7:6	R/W	0	D_REC_MCLK Phase control to latch REC DRAM data in 11: 135 deg phase shift 10: 90 deg phase shift 01: 45 deg phase shift 00: No phase shift
5:4	R/W	0	D_LCD_MCLK Phase control to latch LCD DRAM data in 11: 135 deg phase shift 10: 90 deg phase shift 01: 45 deg phase shift 00: No phase shift
3:2	R/W	0	MCLK Phase control for REC DRAM controller 11: 135 deg phase shift 10: 90 deg phase shift 01: 45 deg phase shift 00: No phase shift
1:0	R/W	0	MCLK Phase control for LCD DRAM controller 11: 135 deg phase shift 10: 90 deg phase shift 01: 45 deg phase shift 00: No phase shift

VCLK PLL DIVIDER CONTROL REGISTER 2 —OFFSET 0X221

Bit	R/W	Default	Description
7:5	R/W	3'h4	DM_FCLK Divide Control 3'h7 : Vclk_divQ equal 16 3'h6 : Vclk_divQ equal 28 3'h5 : Vclk_divQ equal 12 3'h4 : Vclk_divQ equal 10 3'h3 : Vclk_divQ equal 8 3'h2 : Vclk_divQ equal 7 3'h1 : Vclk_divQ equal 6 3'h0 : Vclk_divQ equal 4
4	R/W	0	DM_FCLK phase control 1 : invert 0 : not invert
3:1	R/W	3'h4	VCLK2 Divide Control and phase control by VCLK phase control register 0x223 3'h7 : Vclk_divQ equal 16 3'h6 : Vclk_divQ equal 28 3'h5 : Vclk_divQ equal 12 3'h4 : Vclk_divQ equal 10 3'h3 : Vclk_divQ equal 8 3'h2 : Vclk_divQ equal 7 3'h1 : Vclk_divQ equal 6 3'h0 : Vclk_divQ equal 4
0	R/W	0	VCLK2 phase control used for lcd_dac_clk and HDMI clk 1 : invert 0 : not invert

VCLK PLL DIVIDER CONTROL REGISTER 3 —OFFSET 0X222

Bit	R/W	Default	Description
7:6	R/W	0	VCLK1 source from SCLK 11 : SCK108 MHz 10 : SCK54 MHz 01 : SCK13.5 MHz 00 : use VCLK PLL to generate the VCLK1 frequency
5:4	R/W	0	VCLK source from SCLK 11 : SCK108 MHz 10 : SCK27 MHz 01 : SCK13.5 MHz 00 : use VCLK PLL to generate the VCLK frequency
3:1	R/W	3'h4	DM_VCLK Divide Control 3'h7 : Vclk_divQ equal 16 3'h6 : Vclk_divQ equal 28 3'h5 : Vclk_divQ equal 12 3'h4 : Vclk_divQ equal 10 3'h3 : Vclk_divQ equal 8 3'h2 : Vclk_divQ equal 7 3'h1 : Vclk_divQ equal 6 3'h0 : Vclk_divQ equal 4
0	R/W	0	DM_VCLK phase control

Bit	R/W	Default	Description
			1 : invert 0 : not invert

VCLK PLL DIVIDER CONTROL REGISTER 4 —OFFSET 0X223

Bit	R/W	Default	Description
7:6	R/W	0	VCLK1, DM_VCLK phase control 11: 135 deg phase shift 10: 90 deg phase shift 01: 45 deg phase shift 00: No phase shift
5:4	R/W	0	VCLK2, DM_FCLK phase control 11: 135 deg phase shift 10: 90 deg phase shift 01: 45 deg phase shift 00: No phase shift
3	R/W	0	HDMI_CLK Phase Control 1: Invert VCLK as the HDMI_CLK 0: Use VCLK as the HDMI_CLK
2	R/W	0	LCD_DAC_CLK Phase Control 1: Invert VCLK as the LCD_DAC_CLK 0: Use VCLK as the LCD _DAC_CLK
1:0	R/W	0	VCLK2 source from SCLK 11 : SCK108 MHz 10 : SCK54 MHz 01 : SCK27 MHz 00 : use VCLK PLL to generate the VCLK frequency

LP_CON1 X CONTROL REGISTER —OFFSET 0X224

Bit	R/W	Default	Description
7		0	Reserve
6:4	R/W	100	Playback Port 1 data is from: 111: rec4 port 110: rec3 port 101: rec2 port 100: rec1 port 011: PB4 port 010: PB3 port 001: PB2 port 000: PB1 port
3:0	R/W	1000	Playback port 1 clock is coming from: 1111: rec4_clkn 1110: rec4_clkp 1101: rec3_clkn 1100: rec3_clkp 1011: rec2_clkn 1010: rec2_clkp 1001: rec1_clkn 1000: rec1_clkp

Bit	R/W	Default	Description
			0111: pb4_clkn 0110: pb3_clkn 0101: pb2_clkn 0100: pb1_clkn 0011: pb4_clkp 0010: pb3_clkp 0001: pb2_clkp 0000: pb1_clkp

LP_CON2 X CONTROL REGISTER –OFFSET 0X225

Bit	R/W	Default	Description
7		0	Reserve
6:4	R/W	101	Playback Port 2 data is from: 111: rec4 port 110: rec3 port 101: rec2 port 100: rec1 port 011: PB4 port 010: PB3 port 001: PB2 port 000: PB1 port
3:0	R/W	1010	Playback port 2 clock is coming from: 1111: rec4_clkn 1110: rec4_clkp 1101: rec3_clkn 1100: rec3_clkp 1011: rec2_clkn 1010: rec2_clkp 1001: rec1_clkn 1000: rec1_clkp 0111: pb4_clkn 0110: pb3_clkn 0101: pb2_clkn 0100: pb1_clkn 0011: pb4_clkp 0010: pb3_clkp 0001: pb2_clkp 0000: pb1_clkp

LP_CON3 X CONTROL REGISTER —OFFSET 0X226

Bit	R/W	Default	Description
7		0	Reserve
6:4	R/W	110	Playback Port 3 data is from: 111: rec4 port 110: rec3 port 101: rec2 port 100: rec1 port 011: PB4 port 010: PB3 port 001: PB2 port 000: PB1 port
3:0	R/W	1100	Playback port 3 clock is coming from: 1111: rec4_clkn 1110: rec4_clkp 1101: rec3_clkn 1100: rec3_clkp 1011: rec2_clkn 1010: rec2_clkp 1001: rec1_clkn 1000: rec1_clkp 0111: pb4_clkn 0110: pb3_clkn 0101: pb2_clkn 0100: pb1_clkn 0011: pb4_clkp 0010: pb3_clkp 0001: pb2_clkp 0000: pb1_clkp

LP_CON4 X CONTROL REGISTER —OFFSET 0X227

Bit	R/W	Default	Description
7		0	Reserve
6:4	R/W	111	Playback Port 4 data is from: 111: rec4 port 110: rec3 port 101: rec2 port 100: rec1 port 011: PB4 port 010: PB3 port 001: PB2 port 000: PB1 port
3:0	R/W	1110	Playback port 4 clock is coming from: 1111: rec4_clkn 1110: rec4_clkp 1101: rec3_clkn 1100: rec3_clkp 1011: rec2_clkn 1010: rec2_clkp 1001: rec1_clkn 1000: rec1_clkp 0111: pb4_clkn 0110: pb3_clkn 0101: pb2_clkn

Bit	R/W	Default	Description
			0100: pb1_clkn 0011: pb4_clkp 0010: pb3_clkp 0001: pb2_clkp 0000: pb1_clkp

AUDIO CONTROL 1 REGISTER – 0X228

Bit	R/W	Default	Description
7:6	R/W	0	Port_sel[1:0] There are four i ² s data input pin. This register select which pin will be sent to HDMI. 00: port 1 01: port 2 10: port 3 11: port 4
5	R/W	0	Bypass_i2s When enable this bit, i ² s data will be directly sent to HDMI. For TW2864 I ² S data, this bit must be set to 0
4	R/W	0	Mute 0: normal sound 1: mute
3:0	R/W	0	Ch_sel Select one of the 16 channels from TW2864

AUDIO CONTROL 2 REGISTER – 0X229

Bit	R/W	Default	Description
7	R/W	0	Asclk_sel ASCLK is for SPDIF format. This clock can be selected from external clock or from ck108 on chip. 0: external pin 1: internal 108MHz
6	R/W	0	Audio_master 0: slave mode, TW2864 provide clock 1: master mode, TW2880 provide clock
5	R/W	0	Ups_en 0: no up sample 1: up sample from 6k or 8k to 32k, only useful in master mode
4	R/W	0	Pat_en This bit enable internal pattern

Bit	R/W	Default	Description
3:2	R/W	0	Rate_sel Select sample rate, only useful in master mode 00: 8k 01: 16k 10, 11: 32k
1:0	R/W	0	Pat_freq_sel Pattern selection 00: 1k 01: 2k 10: 4k 11: 8k

RECORDING PIN PORT DATA SELECT REGISTER – 0X22A

Bit	R/W	Default	Description
7	R/W	0	Recording Port 1,2 Source Select 1 = data is from main display / dual monitor 0 = data is from recording unit
6	R/W	0	Recording Port 3,4 Source Select 1 = data is from main display / dual monitor 0 = data is from recording unit
5	R/W	0	Recording Port 1,2 Source Select 1 = data is from dual monitor 0 = data is from main monitor
4	R/W	0	Recording Port 3,4 Source Select 1 = data is from dual monitor 0 = data is from main monitor
3:0	R	00	Reserved

CPU FAST ACCESS CONTROL REGISTER – 0X22C

Bit	R/W	Default	Description
7		0	Freeze Display Pitch register Bit 8 of the Freeze display pitch
6:1	R	0	Reserved
1:0	R/W	11	CPU IO read access to control 11: finish read in seven sclk 10: finish read in six sclk 01: finish read in five sclk 00: finish read in four sclk

CPU FREEZE DISPLAY PITCH REGISTER – 0X22D

Bit	R/W	Default	Description
7:0		0	Freeze Display Pitch register [8:0] Bit [7:0] of the Freeze display pitch register

SCLK PHASE CONTROL REGISTER 3 –OFFSET 0X22E

Bit	R/W	Default	Description
7:3		0	Reserved
2:1	R/W	0	NETWORK_CLK Phase shift select 11: 270° phase shift 10: 180° phase shift 01: 90° phase shift 00: No phase shift
0	R/W	0	NETWORK_CLK Phase Select 1: Inverts the NETWORK_CLK 0: Normal

DRAM ADDRESS MAPPING REGISTER – 0X26D

Bit	R/W	Default	Description
7:3	R	0	Reserved
2	R/W	0	Record DRAM Controller Address Mapping Option 1 = New 0 = Original
1	R	0	Reserved
0	R/W	0	Display DRAM Controller Address Mapping Option 1 = New 0 = Original

CHIP ID REGISTER – 0X270

Bit	R/W	Default	Description
7:4	R	0	28 Series ID Other = Reserved 0000 = TW2880
3:0	R	0	Stepping Other = Reserved 0001 = B1 0000 = A2

DISPLAY DRAM PRIORITY ARBITRATION REGISTER 1 – 0X280

Bit	R/W	Default	Description
7:0	R/W	0	<p>Priority Arbitration[7:0]</p> <p>Set 1 to enable Clients arbitrate with high priority</p> <p>Following table show client round robin number for each module</p> <ul style="list-style-type: none"> 0 : lcd 1 : dmon 2 : di_wr 3 : rgbw 4 : di_rd 5 : spot_osd 6 : osgrd1 7 : osgrd2 8 : osgrd3 9 : dm_osgrd1 10 : dm_osgrd2 11 : host_dma 12 : osgw 13 : freeze 14 : cpu 15 : lcd_mouse 16 : dm_mouse

DISPLAY DRAM PRIORITY ARBITRATION REGISTER 2 – 0X281

Bit	R/W	Default	Description
7:0	R/W	0	<p>Priority Arbitration[15:8]</p> <p>See above.</p>

DISPLAY DRAM PRIORITY ARBITRATION REGISTER 3 – 0X282

Bit	R/W	Default	Description
7:0	R/W	0	<p>Priority Arbitration[23:16]</p> <p>See above.</p>

RECORD DRAM PRIORITY ARBITRATION REGISTER 1 – 0X284

Bit	R/W	Default	Description
7:0	R/W	3	<p>Priority Arbitration[7:0]</p> <p>See below.</p>

RECORD DRAM PRIORITY ARBITRATION REGISTER 2 – 0X285

Bit	R/W	Default	Description
7:0	R/W	0	Priority Arbitration[15:8] See below.

RECORD DRAM PRIORITY ARBITRATION REGISTER 3 – 0X286

Bit	R/W	Default	Description
7:0	R/W	0	Priority Arbitration[23:16] Set 1 to enable Clients arbitrate with high priority Following table show client round robin number for each module 0 : recw 1 : spw 2 : qcif 3 : rout1 4 : rout2 5 : rout3 6 : rout4 7 : rout5 8 : rout6 9 : rout7 10 : rout8 11 : net 12 : spot1 13 : spot2 14 : spot3 15 : spot4 16 : mdw 17 : mdr 18 : dma_cpu2

I²C MASTER CONTROL

Introduction

TW2880 I²C master controller is the only interface to get access to the internal HDMI transmitter following the I²C bus specification. This is an embedded design within the TW2880 device. To access the HDMI transmitter slave, the firmware needs to follow a simple procedure routine to write to or read from the HDMI device.

Features

- Only two pair of data and clock lines.
- The operating clock frequency is software programmable.
- Serial, 8-bit oriented data transfers can be made at fast-mode.
- No need to design bus interface because the I²C control is already integrated on-chip.
- Addressing protocol is flexible by register program
- To start the bus, only three registers need to be written in parallel interface.

Operation

By accessing the parallel host registers in the register page 7, the I²C master controller will convert the registers data to serial data according to the I²C specification. For the registers definition, please refer to the register section.

To write to the HDMI registers, The following steps need to be followed:

Program the register I²C master registers 'X70, 71 to determine the I²C bus frequency.

To write data to the HDMI registers.

First select the I²C master address 'X72 with data 'X72 which is the HDMI slave address, write to the I²C master address 'X74 with data 'X96 which will kick off the I²C START operation. The I²C master initiates the START command and puts 'X72 to the serial data bus SDA along with the SCL clock. If the I²C master receives the ACK signal from the HDMI slave, it will turn on the INT and set the proper bit in the status register.

Clear the interrupt flag, write data 'X0f to I²C master controller command register address 'X74 to clear the interrupt flag.

Write 'X72 with the HDMI register address 'X_addr

Write 'X74 with the 'X16 which will continue put 'Xdd on the I²C bus

wait for the HDMI ACK

Clear the interrupt as 3.

Write 'X72 with the HDMI register data 'X_data

Wait for the HDMI ACK

Clear the interrupt by 'X4F to finish the I²C STOP operation.

For the next HDMI register write, repeat numbers 2 to 10 again.

To read from the HDMI registers, The following steps need to be followed:

Write to I²C master address 'X72 with HDMI slave address 'X72

Wait for the HDMI ACK respond

Clear the interrupt by write 'X74 with 'X0F

Write to I²C master address 'X72 with HDMI register address 'X_addr

Wait for the HDMI ACK respond

Write to the I²C master address 'X72 with HDMI slave address + R 'X73

Wait for the HDMI ACK respond

Clear the interrupt by writing 'X74 with 'X0F

Write to I²C master 'X74 with the value 'X26

Wait for the interrupt flag

READ I²C master register 'X73 which stored the read HDMI value.

Register Table

Address	R/W	Default	Description
0x770	R/W	0x00	I ² C Bus Frequency Control Register (Lower)
0x771	R/W	0x00	I ² C Bus Frequency Control Register (Higher)
0x772	R/W	0x00	I ² C Command / Data Register
0x773	R/W	0x00	I ² C Data Read Register
0x774	R/W	0x00	I ² C Command Register
0x775	R/W	0x00	I ² C Command Status Register

Registers

I²C BUS FREQUENCY CONTROL REGISTER (LOWER)—OFFSET 0X770

Bit	R/W	Default	Description
7-0	R/W	dd	I ² C bus frequency control lower 8 bits

I²C BUS FREQUENCY CONTROL REGISTER (UPPER)—OFFSET 0X771

Bit	R/W	Default	Description
7-0	R/W	00	I ² C bus frequency control upper 8 bits

I²C COMMAND / DATA REGISTER —OFFSET 0X772

Bit	R/W	Default	Description
7-0	R/W	0	[7:0] I ² C slave address [7:1] and R/W command [0] control Or use as data register To access HDMI write, the value should be program 'X72 / 'x7A To access HDMI read, the value should be program 'X73 / 'x7B B0 = 0 write command B0 = 1 Read command

I²C DATA READ REGISTER —OFFSET 0X773

Bit	R/W	Default	Description
7-0	R/W	dd	I ² C Data Read Register

I²C COMMAND REGISTER —OFFSET 0X774

Bit	R/W	Default	Description
7	R/W	0	I ² C START
6	R/W	0	I ² C STOP
5	R/W	0	Read the value from the HDMI and put it in the I ² C data read register
4	R/W	0	Write the value in the I ² C slave register or Data register
3	R/W	0	Send the ACK to the I ² C bus when read
2	R/W	0	Clock count enable
1	R/W	0	Interrupt enable
0	R/W	0	Interrupt acknowledge

I²C COMMAND STATUS REGISTER —OFFSET 0X775

Bit	R/W	Default	Description
7	R	0	I ² C START
6	R	0	I ² C STOP
5	R	0	Read the value from the HDMI and put it in the I ² C data read register
4	R	0	Write the value in the I ² C slave register or Data register
3	R	0	Send the ACK to the I ² C bus when read
2	R	0	Clock count enable
1	R	0	Interrupt enable
0	R	0	Interrupt acknowledge

Revision History

SECTION	REVISION SUMMARY	DATE
v0.9	First Setup document directory and copy data from Rev. B 0508 file	07/15/10
v0.91	Modified Privacy windows size info.	07/26/10
	Modified display image to record using BT.1120	07/26/10
	Add Live channel correction registers	07/26/10
	Add non standard definition registers	07/29/10
	Add new rgb_interface registers	07/30/10
	Replace recording section with new file	07/31/10
	Add stop-n-go interrupt register	08/03/10
	Modify 0x3db register description	08/04/10
	Add Privacy counter overflow bit for H and V	08/05/10
	Add PHSYNC[9] overflow bit for VESA 50 Hz mode	08/06/10
	Add user color register to privacy window	08/12/10
	Add OSG Windows address update	08/12/10
	Add Intersil logo	08/12/10
	Delete Gamma Section	08/15/10
	Add overflow bit in privacy windows	08/15/10
	Add ignored channel definition in CHID	08/16/10
	Add register table description for rgb and PB	08/20/10
	Modified DC characteristics	10/11/10
	Modified input and output Min. / Max. value	10/11/10
	Delete HCLK from DMA diagram	10/11/10
	Change host interface read latching diagram	10/28/10
	Fixed 0x4c3.4 definition typo	11/09/10
	Add 0x3ff bit 7 description	12/03/10
	Add DRAM priority control	12/22/10
	Modify PB path selection explanation	12/23/10
	Add 0xc68 record port clock description	01/03/11
	Add 0x201 bit 7 description	01/03/11
	Modified 0x3ff bit 6, 5 meaning	01/06/11
	Modified 0x6fd, 0x6fe register wording	01/14/11
	Correction 0x6f1, 0x6f0 PB mode definition	01/17/11

SECTION	REVISION SUMMARY	DATE
	Correct SPOT register definition for C	02/09/11
	Add DRAM priority register into register table	02/15/11
	Add Channel Ignore description in 0x6fa	02/18/11
	Modified 0x3f2 definition	02/22/11
	Change DMON BT.1120 source	02/23/11
	Fix HDMI Amplitude Control Description typo	03/11/11
	Fix power on sequence voltage / time requirement	03/21/11
	Add 0x6fc [2] description	03/30/11
	Change the wording on PB to include 4 HD port	04/04/11
	Change 0xF18 [5] definition	06/01/11
	Put in more SPOT section register changes	06/02/11
	Perform spelling check	06/24/11
	<p>Added Ordering Information table.</p> <p>Applied Intersil template. Assigned Intersil File Number.</p> <p>Applied Intersil standard watermarks that are required for pre-release datasheet.</p> <p>Removed Techwell Disclaimer on page 1 per Intersil Legal Dept. Replaced by Intersil's standard copyright notice and disclaimer.</p> <p>Updated Spec tables to add Intersil standard note to MIN MAX column (Compliance to datasheet limits is assured by one or more methods: production test, characterization and/or design)</p> <p>Updated Caution statement in Absolute Maximum Ratings table per Intersil Legal.</p> <p>Added Intersil disclaimer to page 635.</p>	6/30/11
	Modified P.184 HDMI I2C port address selection	7/15/11
	Change P.36 resolution road map	7/15/11
	Change summary page description	7/16/11
	Change Page 1 description	8/08/11
	Change SPOT bits description	8/08/11

SECTION	REVISION SUMMARY	DATE
	Add back Host interface table outline	8/08/11
	Change 0x3f8 – 0x3fb default values.	11/10/11
	Change 0xc4[1:0] = 2'b11 definition	11/11/11
	Change the wording and symbol used in 0x3c6 and 0x3ff to make it more clear	11/14/11
	Added Power off sequence to last paragraph in Power On Sequence section on page 604	6/4/13

© Copyright Intersil Americas LLC 2010-2013. All Rights Reserved.
 All trademarks and registered trademarks are the property of their respective owners.

For additional products, see www.intersil.com/product_tree
 Intersil products are manufactured, assembled and tested utilizing ISO9001 quality systems as noted
 in the quality certifications found at <http://www.intersil.com/en/support/qualandreliability.html>

Intersil products are sold by description only. Intersil may modify the circuit design and/or specifications of products at any time without notice, provided that such modification does not, in Intersil's sole judgment, affect the form, fit or function of the product. Accordingly, the reader is cautioned to verify that datasheets are current before placing orders. Information furnished by Intersil is believed to be accurate and reliable. However, no responsibility is assumed by Intersil or its subsidiaries for its use; nor for any infringements of patents or other rights of third parties which may result from its use. No license is granted by implication or otherwise under any patent or patent rights of Intersil or its subsidiaries.

For information regarding Intersil Corporation and its products, see <http://www.intersil.com>