

EVALUATION KIT
AVAILABLE

Low-Cost, 6-Channel SD Plus HD/SD Selectable Video Filters and Buffers

General Description

The MAX11506/MAX11507 integrated filters offer six channels, three for standard-definition (SD) video and three for either SD or high-definition (HD) video, and include +6dB output buffers on each channel. These video filters are ideal for anti-aliasing and DAC smoothing in applications such as set-top boxes, digital video recorders, DVD players, and personal video recorders.

The MAX11506/MAX11507 video inputs feature a transparent clamp compatible with AC- and DC-coupled input signals and allow DAC outputs to be directly coupled. The filters provide -3dB bandwidth of 9.0MHz for the SD filters and 33MHz for the HD filters. Each channel includes an output buffer with a gain of +6dB capable of driving a full 2V_{P-P} video signal into a 150Ω video load. The buffers drive either AC- or DC-coupled loads and assure a blanking level of below 1V after the backmatch resistor. DC-coupling eliminates bulky coupling capacitors.

The MAX11506 offers a flat passband while the MAX11507 features 0.8dB peaking on the three SD-only channels to compensate for system roll-off. The MAX11506/MAX11507 operate from a single +5V supply and are available in the 0°C to +70°C commercial temperature grade. The MAX11506/MAX11507 are offered in the 16-pin QSOP package.

Applications

Cable and Satellite Set-Top Box Receivers
HDTVs
DVD Players
Personal Video Recorders
Digital Video Recorders (DVRs)
SDTVs
Video On-Demand
HD Recorders

Pin Configuration

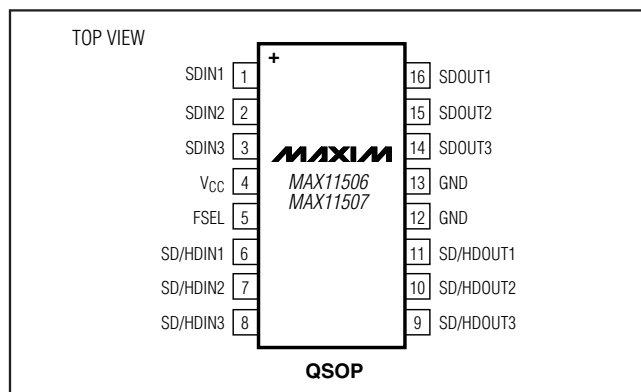

Features

- ◆ Three Selectable 6th-Order 9MHz/33MHz (SD/HD) Filters
- ◆ Three Fixed 5th-Order 9MHz (SD) Filters
- ◆ +6dB Output Buffers
- ◆ Transparent Input Clamp
- ◆ AC- or DC-Coupled Inputs
- ◆ AC- or DC-Coupled Outputs
- ◆ 0.8dB Peaking Passband Response (MAX11507) on Three SD-Only Channels
- ◆ Output Buffers Drive a Standard 150Ω Video Load
- ◆ Single +5V Power Supply
- ◆ Lead-Free 16-Pin QSOP Package

Ordering Information

PART	TEMP RANGE	PIN-PACKAGE	FREQUENCY RESPONSE
MAX11506CEE+	0°C to +70°C	16 QSOP	Flat
MAX11507CEE+	0°C to +70°C	16 QSOP	High Frequency Boost

+Denotes a lead-free package.

Typical Operating Circuit appears at end of data sheet.

Block Diagram

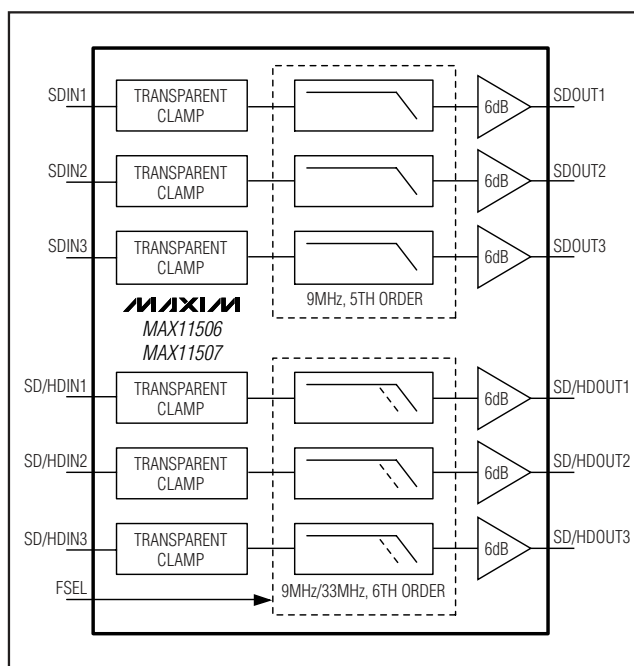

Low-Cost, 6-Channel SD Plus HD/SD Selectable Video Filters and Buffers

ABSOLUTE MAXIMUM RATINGS

V _{CC} to GND	-0.3V to +6V	Maximum Current into Any Pin except V _{CC} and GND	±50mA
All Other Pins to GND	-0.3V to the lower of (V _{CC} + 0.3V) and +6V	Operating Temperature Range	0°C to +70°C
Continuous Power Dissipation (T _A = +70°C)		Storage Temperature Range	-65°C to +150°C
16-Pin QSOP (derate 9.6mW/°C above +70°C)	771.5mW	Lead Temperature (soldering, 10s)	+300°C
		Junction Temperature	+150°C

Stresses beyond those listed under "Absolute Maximum Ratings" may cause permanent damage to the device. These are stress ratings only, and functional operation of the device at these or any other conditions beyond those indicated in the operational sections of the specifications is not implied. Exposure to absolute maximum rating conditions for extended periods may affect device reliability.

DC ELECTRICAL CHARACTERISTICS

(V_{CC} = +5V, R_{LOAD} = 150Ω to GND, C_{IN} = 0.1μF, T_A = 0°C to +70°C, unless otherwise noted.)

PARAMETER	SYMBOL	CONDITIONS	MIN	TYP	MAX	UNITS
Supply Current	I _{CC}			40	61	mA
Supply Voltage Range	V _{CC}		4.75	5.00	5.25	V
Input-Voltage Range	V _{IN}			1.4		V
Digital Input High Voltage	V _{IH}		2.0			V
Digital Input Low Voltage	V _{IL}				0.8	V

AC ELECTRICAL CHARACTERISTICS

(V_{CC} = +5V, R_{LOAD} = 150Ω to GND, C_{IN} = 0.1μF, T_A = 0°C to +70°C, frequency response relative to 100kHz, unless otherwise noted.)

PARAMETER	SYMBOL	CONDITIONS	MIN	TYP	MAX	UNITS
STANDARD-DEFINITION VIDEO						
-1dB Bandwidth	f _{1dB}	MAX11506, SD	4.5	7.9		MHz
		MAX11506, SD/HD in SD mode	4.5	7.9		
		MAX11507, SD	5.0	8.6		
		MAX11507, SD/HD in SD mode	4.5	7.9		
-3dB Bandwidth	f _{3dB}			9.0		MHz
Stopband Attenuation	A _{SB}	f = 27MHz		48		dB
Low-Frequency Gain	A _V	No load	5.8	6.0	6.2	dB
Differential Gain	dG	All channels		0.5		%
Differential Phase	dφ	All channels		0.2		Degrees
Total Harmonic Distortion	THD	V _{OUT} = 1.4V _{P-P} , f = 1MHz (all channels)		0.1		%
Channel-to-Channel Crosstalk	X _{TALK}	f = 1MHz		-60		dB
Signal-to-Noise Ratio	SNR	Peak signal (2V _{P-P}) to RMS noise, 100kHz, 4.2MHz		71		dB
Propagation Delay	t _{PD}	f = 4.5MHz		59		ns
Power-Supply Rejection Ratio	PSRR	DC (all channels)		45		dB

Low-Cost, 6-Channel SD Plus HD/SD Selectable Video Filters and Buffers

MAX11506/MAX11507

AC ELECTRICAL CHARACTERISTICS (continued)

($V_{CC} = +5V$, $R_{LOAD} = 150\Omega$ to GND, $C_{IN} = 0.1\mu F$, $T_A = 0^\circ C$ to $+70^\circ C$, frequency response relative to 100kHz, unless otherwise noted.)

PARAMETER	SYMBOL	CONDITIONS	MIN	TYP	MAX	UNITS
HIGH-DEFINITION VIDEO						
-1dB Bandwidth	f_{1dB}	$T_A = +25^\circ C$	23	30		MHz
-3dB Bandwidth	f_{3dB}			33		MHz
Stopband Attenuation	A_{SB}	$f = 37.125MHz$		4.0		dB
		$f = 44.250MHz$		13		
		$f = 74.250MHz$, $T_A = +25^\circ C$	32.0	46.0		
Low-Frequency Gain	A_V		5.8	6.0	6.2	dB
Total Harmonic Distortion	THD	$V_{OUT} = 1.4V_{P-P}$, $f = 10MHz$		0.4		%
		$V_{OUT} = 1.4V_{P-P}$, $f = 15MHz$		0.4		
		$V_{OUT} = 1.4V_{P-P}$, $f = 22MHz$		0.6		
Channel-to-Channel Crosstalk	X_{TALK}	$f = 1MHz$		-60		dB
Signal-to-Noise Ratio	SNR	Peak signal ($2V_{P-P}$) to RMS noise, 100kHz, 30MHz		65		dB
Group-Delay Deviation	Δt_g	$f = 100kHz$ to 26MHz		15		ns

Typical Operating Characteristics

($V_{CC} = 5V$, $R_L = 150\Omega$ to GND, output DC-coupled, $T_A = +25^\circ C$.)

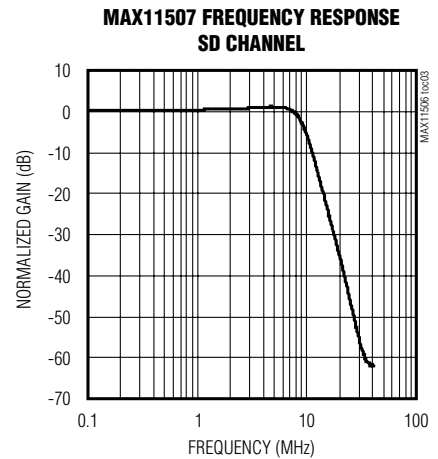
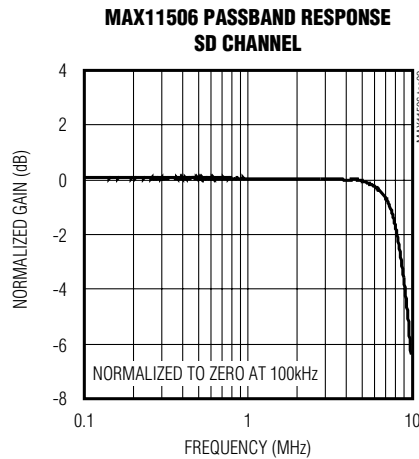
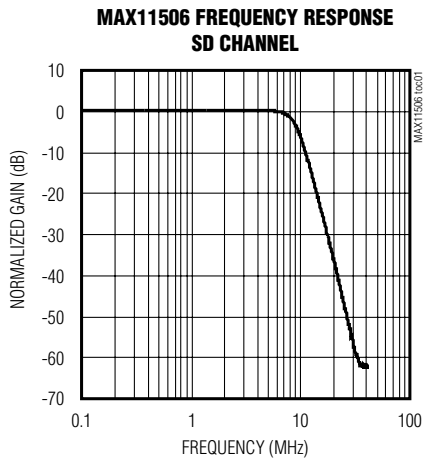

Low-Cost, 6-Channel SD Plus HD/SD Selectable Video Filters and Buffers

Typical Operating Characteristics (continued)

($V_{CC} = 5V$, $R_L = 150\Omega$ to GND, output DC-coupled, $T_A = +25^\circ C$.)

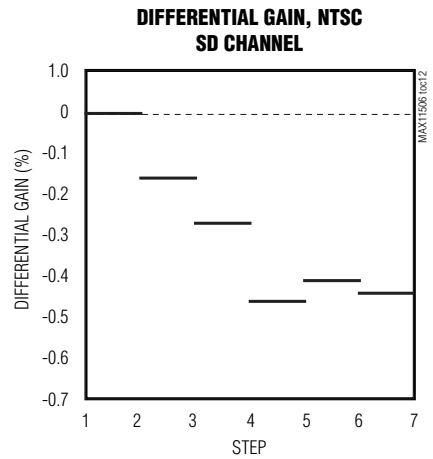
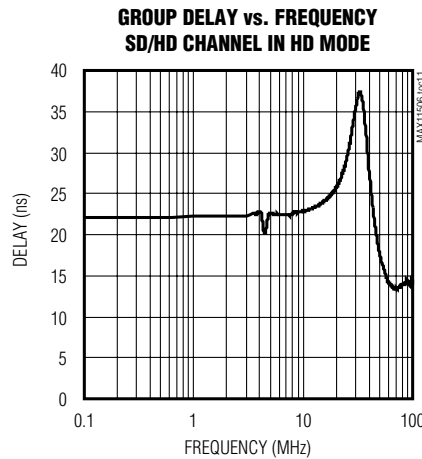
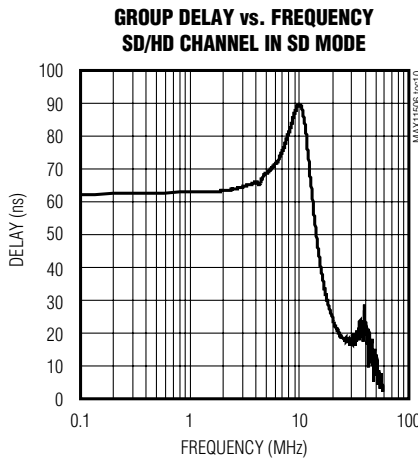
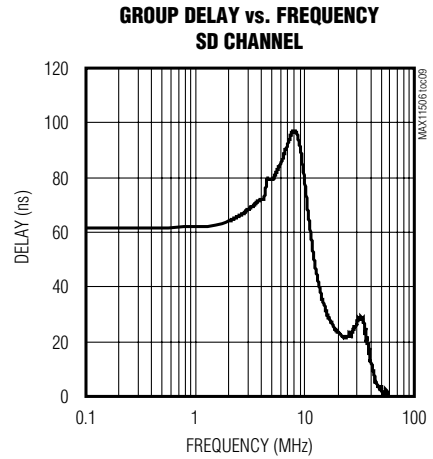
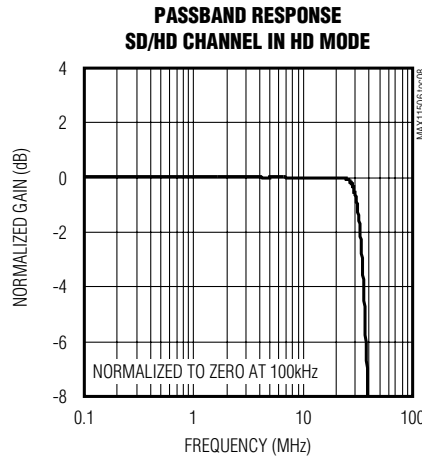
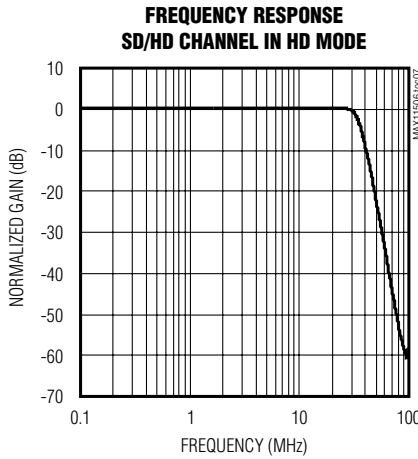
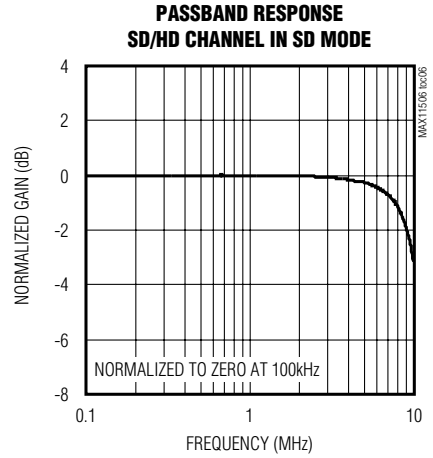
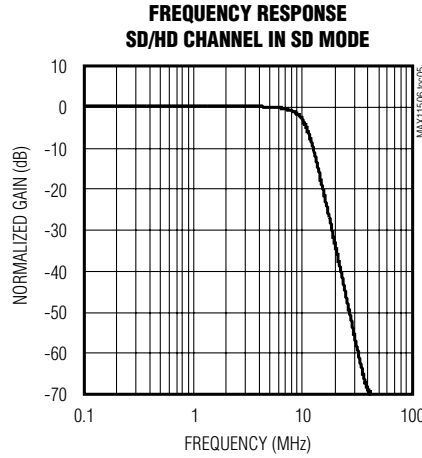
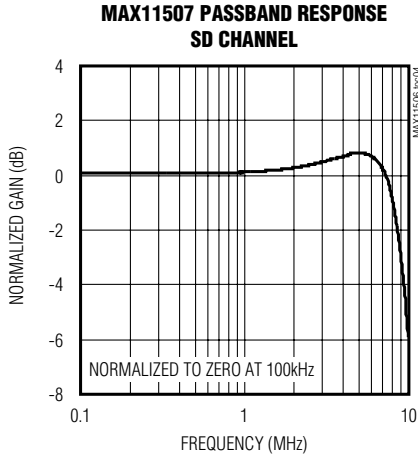

Low-Cost, 6-Channel SD Plus HD/SD Selectable Video Filters and Buffers

Typical Operating Characteristics (continued)

($V_{CC} = 5V$, $R_L = 150\Omega$ to GND, output DC-coupled, $T_A = +25^\circ C$.)

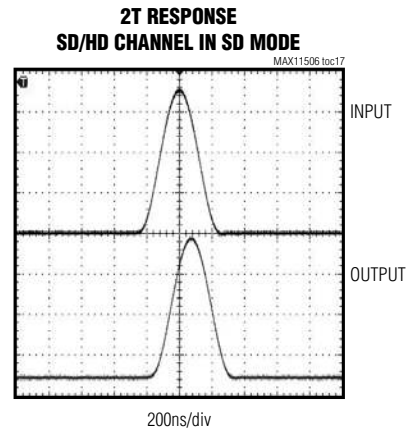
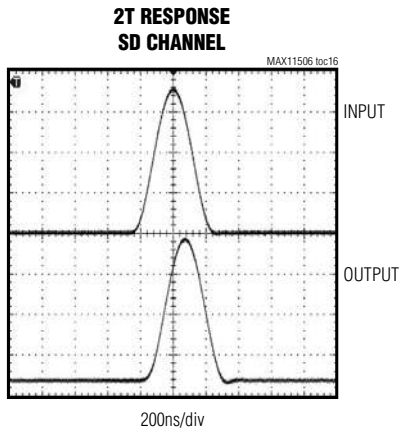
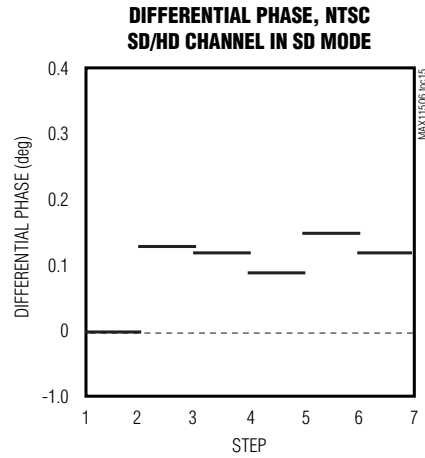
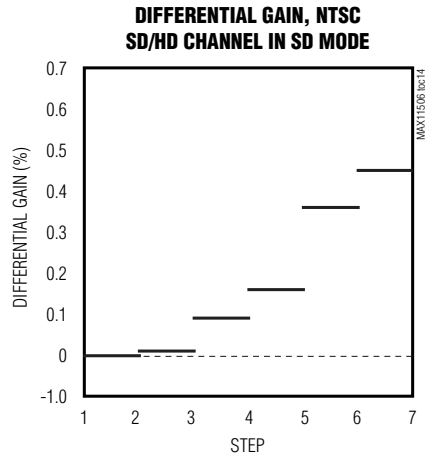
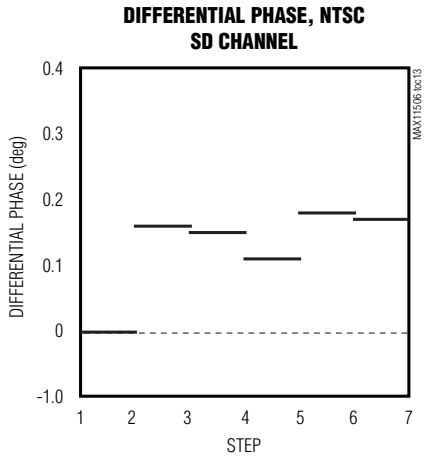

MAX11506/MAX11507

Low-Cost, 6-Channel SD Plus HD/SD Selectable Video Filters and Buffers

Pin Description

PIN	NAME	FUNCTION
1	SDIN1	SD Video Input Channel 1
2	SDIN2	SD Video Input Channel 2
3	SDIN3	SD Video Input Channel 3
4	VCC	Power-Supply Input
5	FSEL	Frequency-Select Input. SD/HD select for channels 4, 5, and 6. Force FSEL high to select HD, and low to select SD. Do not leave unconnected.
6	SD/HDIN1	SD/HD Video Input Channel 1
7	SD/HDIN2	SD/HD Video Input Channel 2
8	SD/HDIN3	SD/HD Video Input Channel 3
9	SD/HDOUT3	SD/HD Video Output Channel 3
10	SD/HDOUT2	SD/HD Video Output Channel 2
11	SD/HDOUT1	SD/HD Video Output Channel 1
12, 13	GND	Ground
14	SDOUT3	SD Video Output Channel 3
15	SDOUT2	SD Video Output Channel 2
16	SDOUT1	SD Video Output Channel 1

Detailed Description

The MAX11506/MAX11507 integrated filters offer 6 channels, 3 for SD video and 3 for either SD or HD video and include +6dB output buffers on each channel. Each channel of the MAX11506/MAX11507 contains a transparent input clamp, a 9.0MHz 5th-order lowpass filter and an output amplifier with a gain of 2V/V (see the *Typical Operating Circuit*). The MAX11506 provides a flat passband response and the MAX11507 provides a 0.8dB high-frequency boost at 5MHz on all SD-only channels to help with system roll-off. The SD-only channels add 280mV of offset at the output.

Three channels, SD/HD1, SD/HD2, and SD/HD3 include selectable SD and HD video filters, each with a transparent input clamp, a 6th-order lowpass filter with a -3dB bandwidth of 9.0MHz (SD) and 33MHz (HD), and an output amplifier with a gain of 2V/V. The SD/HD channels add 550mV of offset at the output.

The output voltage equations are:

$$V_{SDOUT} = (2 \times V_{IN}) + 0.28V$$

$$V_{SD/HDOUT} = (2 \times V_{IN}) + 0.55V$$

Typical voltage waveforms are shown in Figures 1 and 2.

Inputs

Transparent Clamps

All inputs feature transparent clamps to allow either AC- or DC-coupling of the inputs. The clamp remains inactive while the input signal is above ground, offering true DC input coupling. When the signal goes below ground, as is the case when it is AC-coupled, the clamp sets the sync tip close to the ground level.

Input Coupling

The choice of AC- or DC-coupling the input depends on the video source. Many DACs have a current output and are terminated to ground with a resistor; such signals are conveniently DC-coupled. Use AC-coupling when the DC level of the video signal is unknown or outside the specified input range of the MAX11506/MAX11507, such as SCART or VCC-terminated DAC outputs.

DC-Coupled Inputs

When the input is DC-coupled, the voltage must remain above zero but should not exceed 1.4V (typical).

Low-Cost, 6-Channel SD Plus HD/SD Selectable Video Filters and Buffers

MAX11506/MAX11507

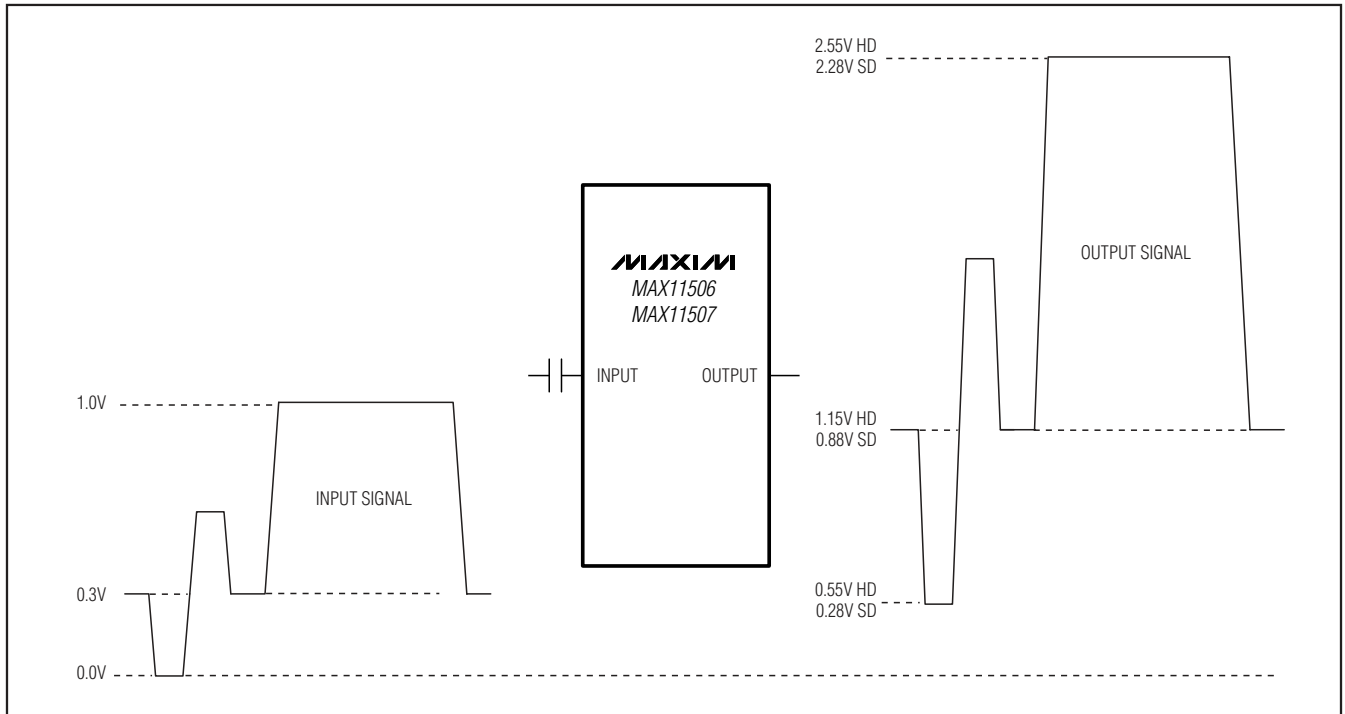

Figure 1. Typical AC-Coupled Signal

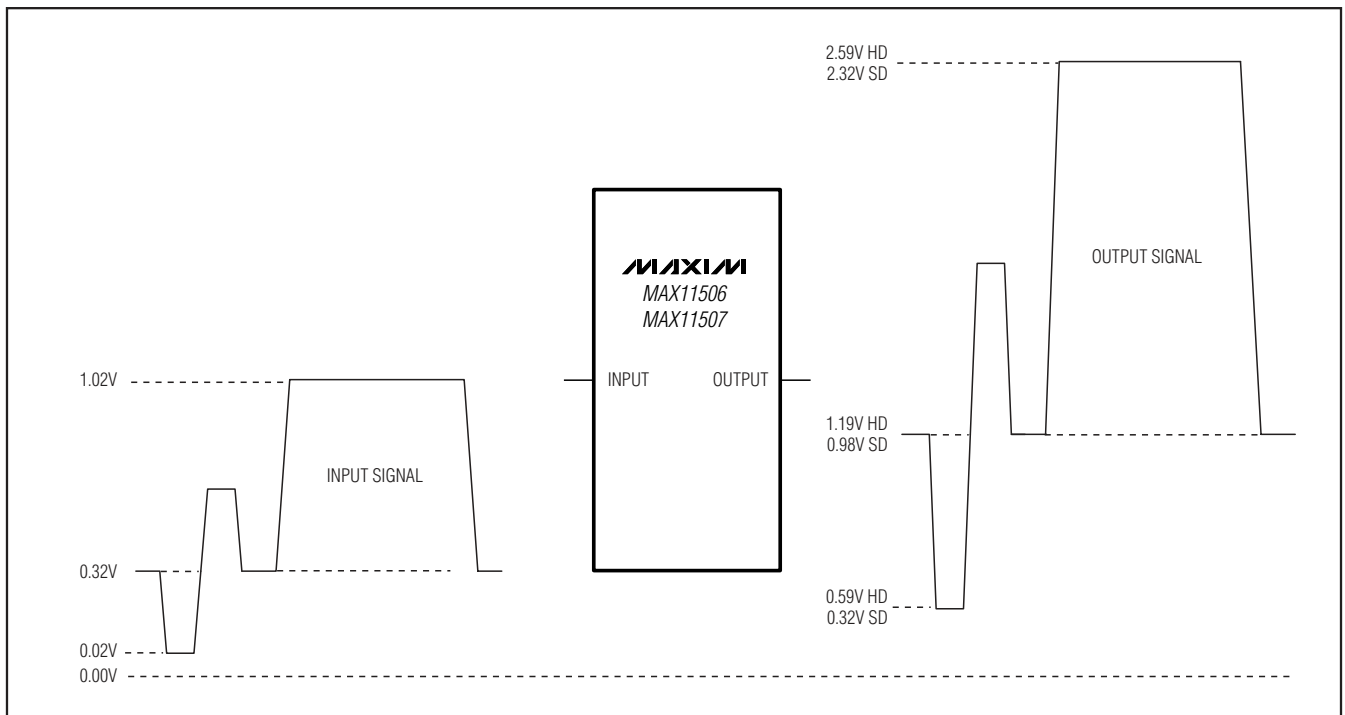

Figure 2. Typical DC-Coupled Signal

Low-Cost, 6-Channel SD Plus HD/SD Selectable Video Filters and Buffers

AC-Coupled Inputs

When the input is AC-coupled, the transparent clamps are active and set the lowest point of the signal at ground. This is appropriate for unipolar signals such as CVBS, Y, R, G, or B, with or without sync pulses (Figure 3).

For bipolar signals such as Pb and Pr, bias the AC-coupled inputs to a fixed DC voltage, typically 0.59V, to ensure that the transparent clamp remains off. Figure 4 shows a typical network. Determine the bias voltage using:

$$V_B = \frac{R_2}{R_1 + R_2} \times (V_{AVCC} - (I_L \times R_1))$$

where I_L is the input leakage current (typically 0.5 μ A).

SD Filters

The MAX11506/MAX11507 filters are optimized to deliver a flat (MAX11506) or high-frequency boosted (MAX11507) passband and high stopband attenuation. The filter characteristic provides excellent time domain response with low overshoot. The typical -3dB frequency of 9.0MHz guarantee minimal attenuation in the passband, while at the same time offering a 27MHz attenuation of typically -48dB.

HD Filters

The internal filters deliver a flat passband along with high stopband attenuation. The filter characteristic provides an excellent time domain response with low overshoot. The typical -3dB frequency of 33MHz guarantees low attenuation in the passband, while at the same time allowing for a typical attenuation of -46dB at 74.25MHz.

Output Buffers

The MAX11506/MAX11507 feature output buffers with +6dB gain that drive a standard 150 Ω video load. A typical load consists of a 75 Ω backmatch resistor, an optional 220 μ F or larger coupling capacitor, and a 75 Ω termination resistor. The offset between input and output signals ensures that the blanking level on the output is less than 1V after the backmatch resistor, thus meeting digital TV specifications allowing the devices to drive video loads directly without using costly AC-coupling capacitors.

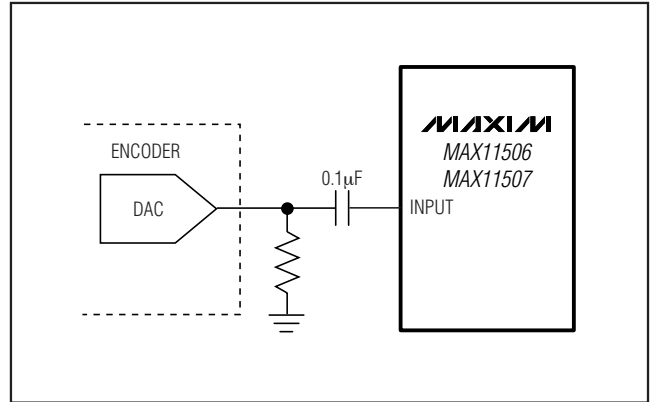

Figure 3. Simple AC-Coupling for Unipolar Signals (CVBS, Y, R, G, B)

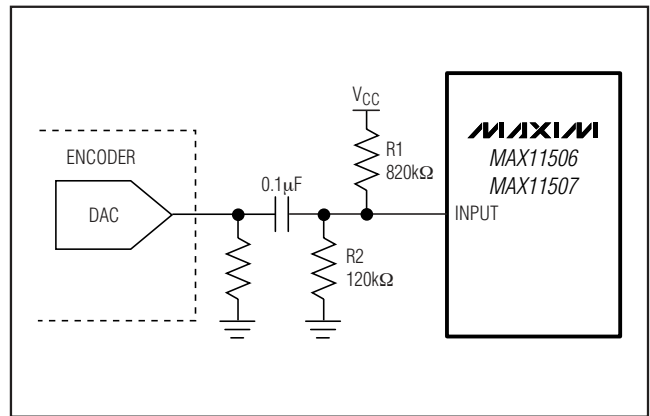

Figure 4. AC-Coupling for Bipolar Signals (C, Pb, Pr)

Applications Information

Output Considerations

The MAX11506/MAX11507 outputs may be DC- or AC-coupled. These devices, with +6dB gain, are typically connected to a 75 Ω series backmatch resistor followed by the video cable. Choose an AC-coupling capacitor value that ensures that the lowest frequency content in the video signal is passed and the field-time distortion is kept within desired limits when using an AC connection. The selection of this value is a function of the input impedance, and more importantly, the input leakage of the circuit being driven. Common industry practice is to use a 220 μ F or larger capacitor.

Low-Cost, 6-Channel SD Plus HD/SD Selectable Video Filters and Buffers

The MAX11506/MAX11507 outputs are fully protected against short circuits to ground. The short-circuit protection circuitry limits the output current to 75mA (typical) per output. Shorting more than one output to ground simultaneously may exceed the maximum package power dissipation.

PCB Layout Recommendations

Connect the power and ground traces to large copper areas to enhance power dissipation. Bypass VCC to GND with 0.1µF and 1.0µF capacitors. Place the 0.1µF capacitor closest to VCC. Use surface-mount capacitors

for their low inductance. Place traces carrying video signals appropriately to avoid mutual coupling. When inputs are AC-coupled, place the capacitors as close as possible to the device and keep traces short to minimize parasitic capacitance and inductance. Refer to the MAX11506/MAX11507 evaluation kit datasheet for PCB layout.

Chip Information

PROCESS: BiCMOS

Typical Operating Circuit

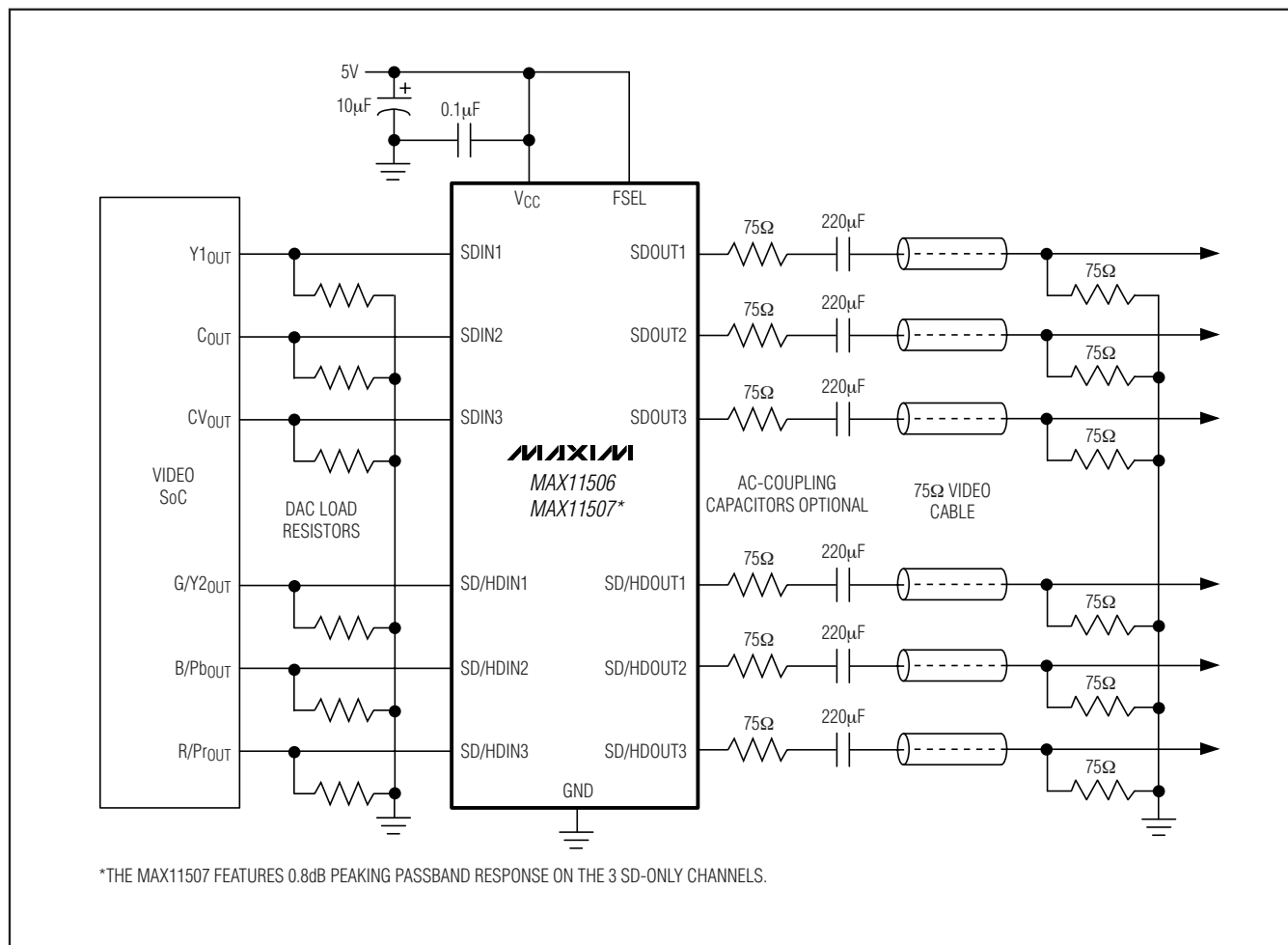

MAX11506/MAX11507

Low-Cost, 6-Channel SD Plus HD/SD Selectable Video Filters and Buffers

Package Information

For the latest package outline information, go to www.maxim-ic.com/packages.

PACKAGE TYPE	PACKAGE CODE	DOCUMENT NO.
16 QSOP	E16+1	21-0055

Maxim cannot assume responsibility for use of any circuitry other than circuitry entirely embodied in a Maxim product. No circuit patent licenses are implied. Maxim reserves the right to change the circuitry and specifications without notice at any time.

10 **Maxim Integrated Products, 120 San Gabriel Drive, Sunnyvale, CA 94086 408-737-7600**