

SOCKET CONTACT

PIN CONTACT

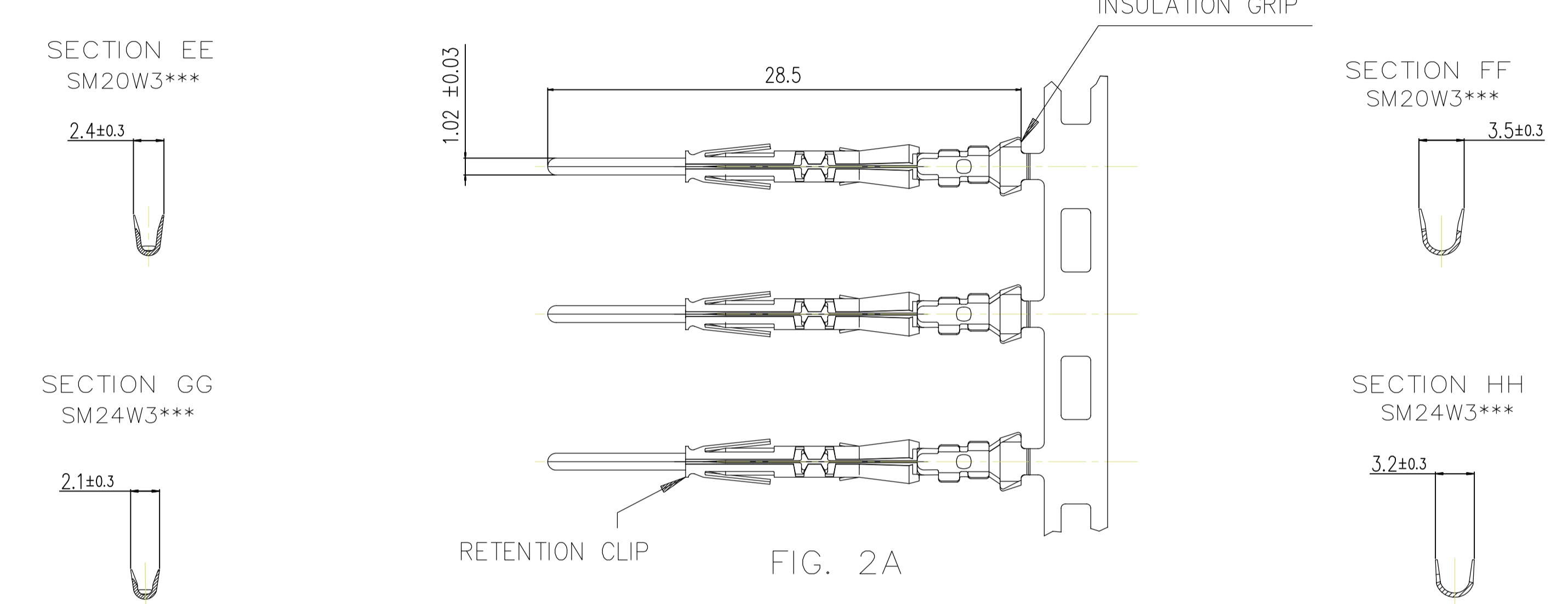
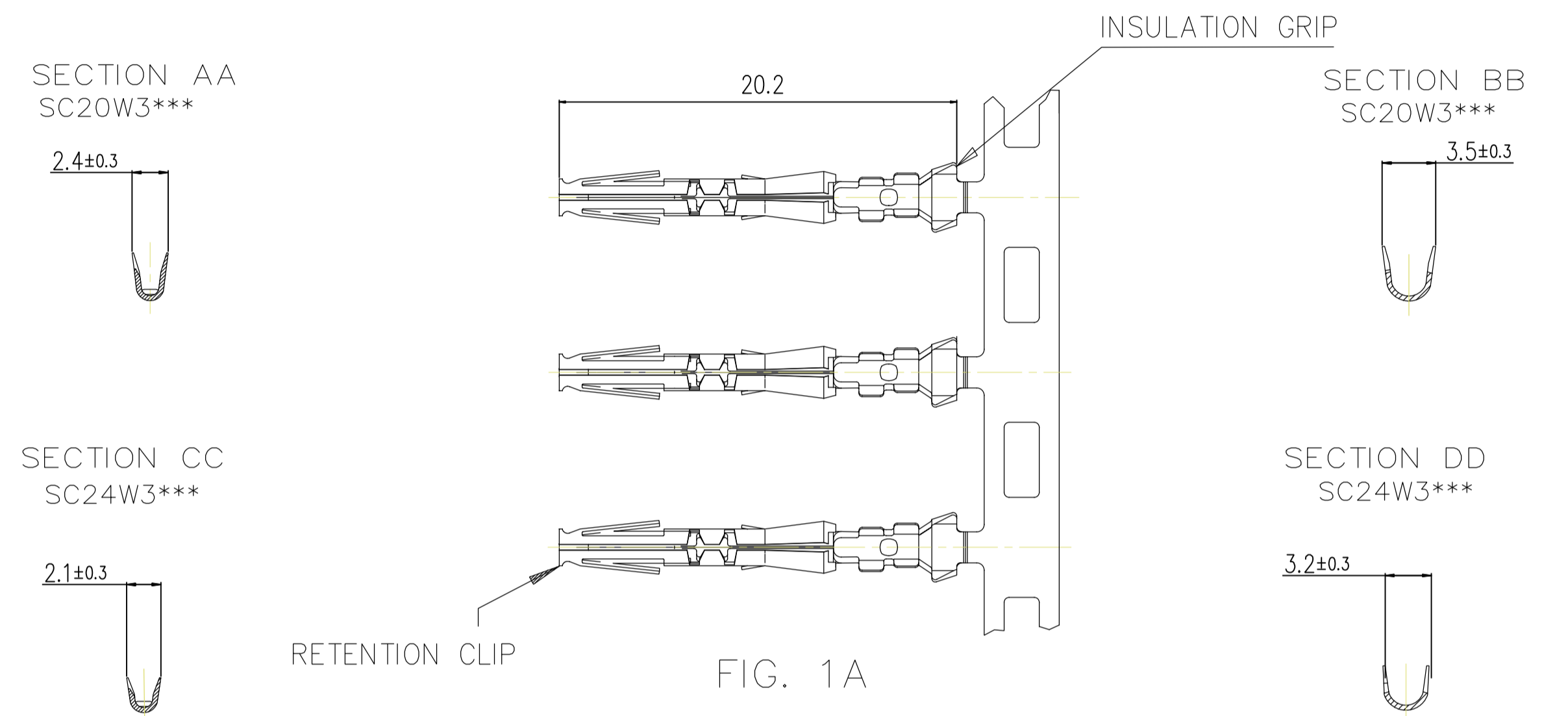

	CONTACT CAT. N°	FIG.	PACKING	WIRE SIZE		WIRE INSUL. DIAM. IN MM.	WIRE STRIP LENGTH IN MM.	HAND CRIMP TOOLING		EXTRACTION TOOL
				AWG	MM ²			DIE SET	HANDTOOL FOR LOOSE PIECE	
SOCKET	SC24W3S25 / SC24W3TK6	1A	3000 PER REEL	26/24	0.12/0.25	0.90/1.60	4.0	 	 	RX20D44
	SC24WL3S25 / SC24WL3TK6	1B	100 IN A PLASTIC BAG					S20SCM20	SHANDLES	
	SC20W3S25 / SC20W3TK6	1A	3000 PER REEL	22/20	0.32/0.50	1.20/2.10	4.0	 	 	
SC20WL3S25 / SC20WL3TK6	1C	100 IN A PLASTIC BAG					S20SCM20	SHANDLES		
PIN	SM24W3S26 / SM24W3TK6	2A	3000 PER REEL	26/24	0.12/0.25	0.90/1.60	4.0	 	 	
	SM24WL3S26 / SM24WL3TK6	2B	100 IN A PLASTIC BAG					S20SCM20	SHANDLES	
	SM20W3S26 / SM20W3TK6	2A	3000 PER REEL	22/20	0.32/0.50	1.20/2.10	4.0	 	 	
	SM20WL3S26 / SM20WL3TK6	2C	100 IN A PLASTIC BAG					S20SCM20	SHANDLES	

MALE AND FEMALE CONTACTS SIZE 20

CONSTRUCTION

CONTACT BODY : HIGH CONDUCTIVITY COPPER ALLOY.
OUTER SPRING : STAINLESS STEEL.

PACKING CONTACTS ON STRIP : 3000 PCS. PER REEL
PACKING LOOSE PIECE CONTACTS : 100 PCS PER PLASTIC BAG



CONNECTOR ACCOMMODATION

THESE CONTACTS CAN BE USED IN ANY CONTACT POSITION IN ANY CONNECTOR IN THE TRIM TRIO SEALOK INTERCONNECTION SYSTEM : UTGW CONN., UTOW CONN., UTS CONN.

PERFORMANCE CHARACTERISTICS

CURRENT RATING : 5 A
CONTACT RESISTANCE : <= 15 m Ohm
OPERATING VOLTAGE : 1500 V RMS

CONTACT RETENTION IN BODY : 50 N MIN.
INDIVIDUAL INSERTION FORCE : 5 N MAX.
INDIVIDUAL WITHDRAWAL FORCE : 0.3 N MIN.

P/N : SEE TABLE

ISS	DATE	Update of the dimensions for the 'U' shape Update drawing	RDULLARD Ch	MOD N°
Designed by:	A.Janssens	Date : 23-04-97	CUSTOMER DRAWING	
TITLE	SEALOK MALE AND FEMALE FORMED CONTACT SM--W(L)3*** / SC--W(L)3***			
Scale	1/1	Dimensions in mm General linear Tolerances: ± 0.2	NPRDS / PROJECT TT	
SOURIAU Connection Technologies		www.souriau.com	This document is the property of SOURIAU It must not be reproduced or communicated without permission	
FORMAT	A1	SOURIAU DRG N° BS-C-202338-001	SHEET 1 / 1	

Country	Jurisdiction & Control List
FR	NDT LISTED

SOURIAU shall not be liable for any non-conformity or damage due to a use of the Products which does not comply with the Specifications issued by either of the Parties or by a third party (professional recommendation, technical notice.)