

## ■ Features

Shock detection sensor ideal for security of gaming machines.

- Behavior of built-in metal ball depends on external shock. The detection of its movement allows the detection of specific types of shock likely to affect pachinko balls.
- Intermittent output of detection signals upon shock detection.
- Two-wire DC output with built-in connector.



## ■ Type code standard

Type W2DL-02 (1) Represents an shock detection sensor (2) Represents a series name

## ■ Specifications

Item	Rating/performance
Detected shock strength (*1)	Peak acceleration: 10 to 20 m/s <sup>2</sup> Operating time: 4 ms Waveform type: Half sign wave
Power voltage	12 DCV±10%, 15 DCV±10%, 18 DCV±10%, 24 DCV±10%
Leakage current (*2)	0.2 to 1.0mA
Residual voltage (*3)	Under power voltage 12 DCV: 5.4 to 7 V, Under power voltage 15 DCV: 5.4 to 7 V Under power voltage 18 DCV: 5.4 to 7 V, Under power voltage 24 DCV: 5.4 to 7 V
Load resistance	Under power voltage 12 DCV ± 10%: 680 Ω (-5%) to 1.1 kΩ (+5%) Under power voltage 15 DCV ± 10%: 1.1 kΩ (-5%) to 1.6 kΩ (+5%) Under power voltage 18 DCV ± 10%: 1.5 kΩ (-5%) to 2.2 kΩ (+5%) Under power voltage 24 DCV ± 10%: 2.2 kΩ (-5%) to 3.6 kΩ (+5%)
Way of operation	When shock detected: Output transistor ON/OFF (intermittent output) When shock not detected: Output transistor OFF
Ambient temperature	When in operation: 0 to 60 deg C (must be free from freezing or condensation) When stored: -20 to 70 deg C (must be free from freezing or condensation)
Ambient humidity	25 to 85% RH

\*1. In accordance with the shock test described in JISC60068-2-27, detected shock strength is defined in terms of peak acceleration, operating time, and waveform type. The values for detected shock strength are provided with our standard testing machine.

\*2. Leakage current refers to the current running through the shock detection sensor when the output transistor is off.

\*3. Residual pressure refers to the voltage generated at both ends of the shock detection sensor when the output transistor is on.

## ■ Output circuit diagram

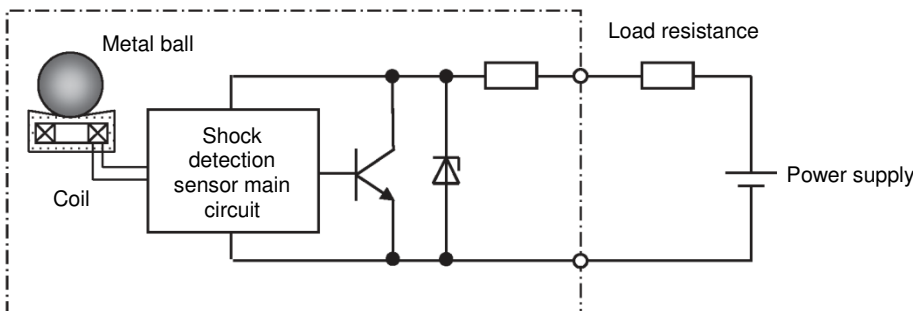

## ■ Operation chart

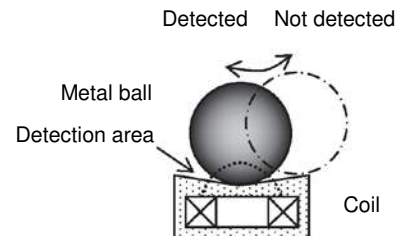
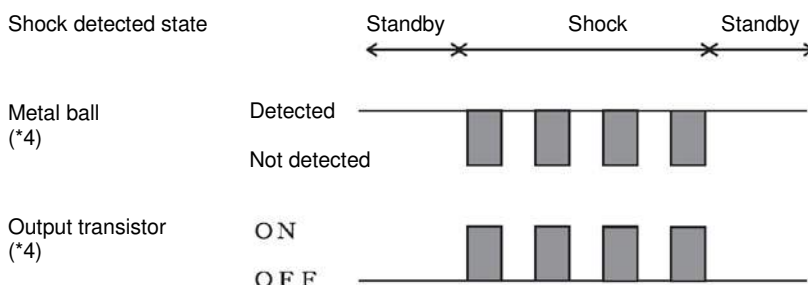

\*4. Whether the metal ball built in the sensor is detected or not determines the ON/OFF state of the output transistor. (Intermittent output)

■ Exterior dimensions

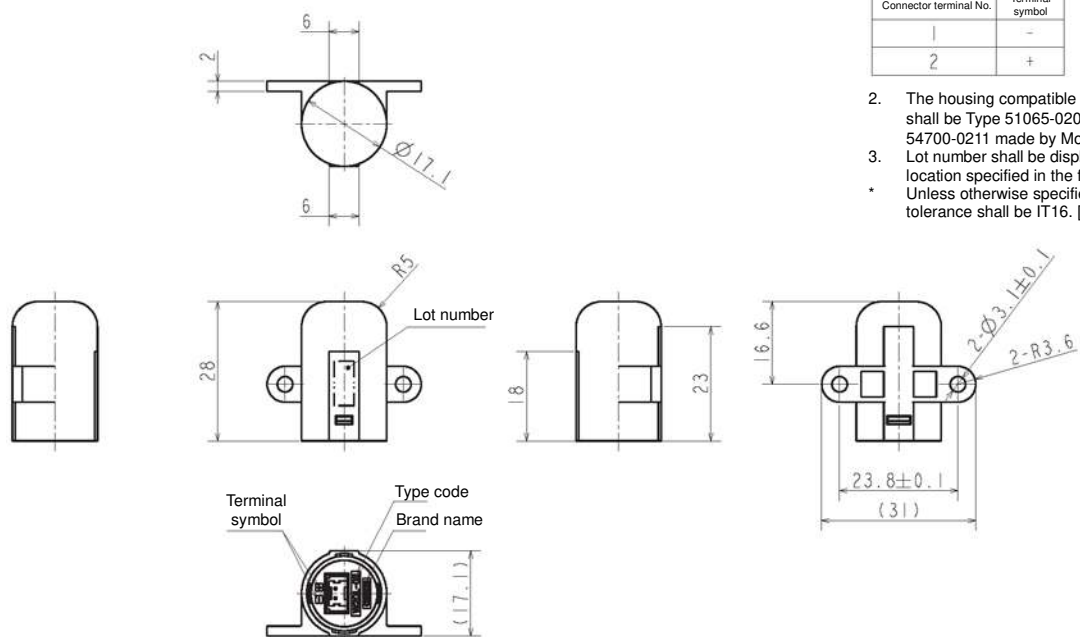

Note: 1. The following shows the relationship between the connector terminal numbers and terminal symbols.

Connector terminal No.	Terminal symbol
1	-
2	+

2. The housing compatible with the connector shall be Type 51065-020□ series or Type 54700-0211 made by Molex Japan LLC.
3. Lot number shall be displayed in 4 digits at the location specified in the figure.
- \* Unless otherwise specified, the dimensional tolerance shall be IT16. [Unit: mm]

■ Precautions for use

(1) Installation method

The internal metal ball of the shock detection sensor remains stationary due to its own weight. When installing the sensor, make the central axis of the sensor vertical with the connector facing down. Insufficient fixing of the shock detection sensor may cause malfunction due to shock that cannot be correctly transmitted to the sensor. Attach the sensor firmly to the mounting surface with screws.

(2) Effects of magnetic field

The shock detection sensor detects the movement of its internal metal ball. In a strong magnetic field, the ball may behave differently, which results in malfunction. When installing a part that generates a magnetic field near the sensor, check that the sensor works normally before using it.

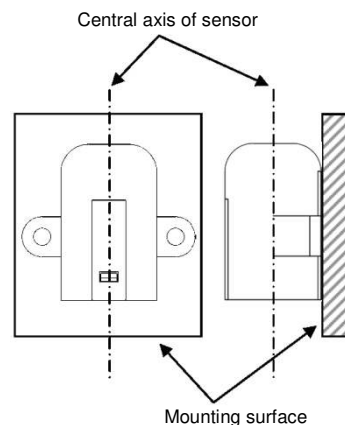

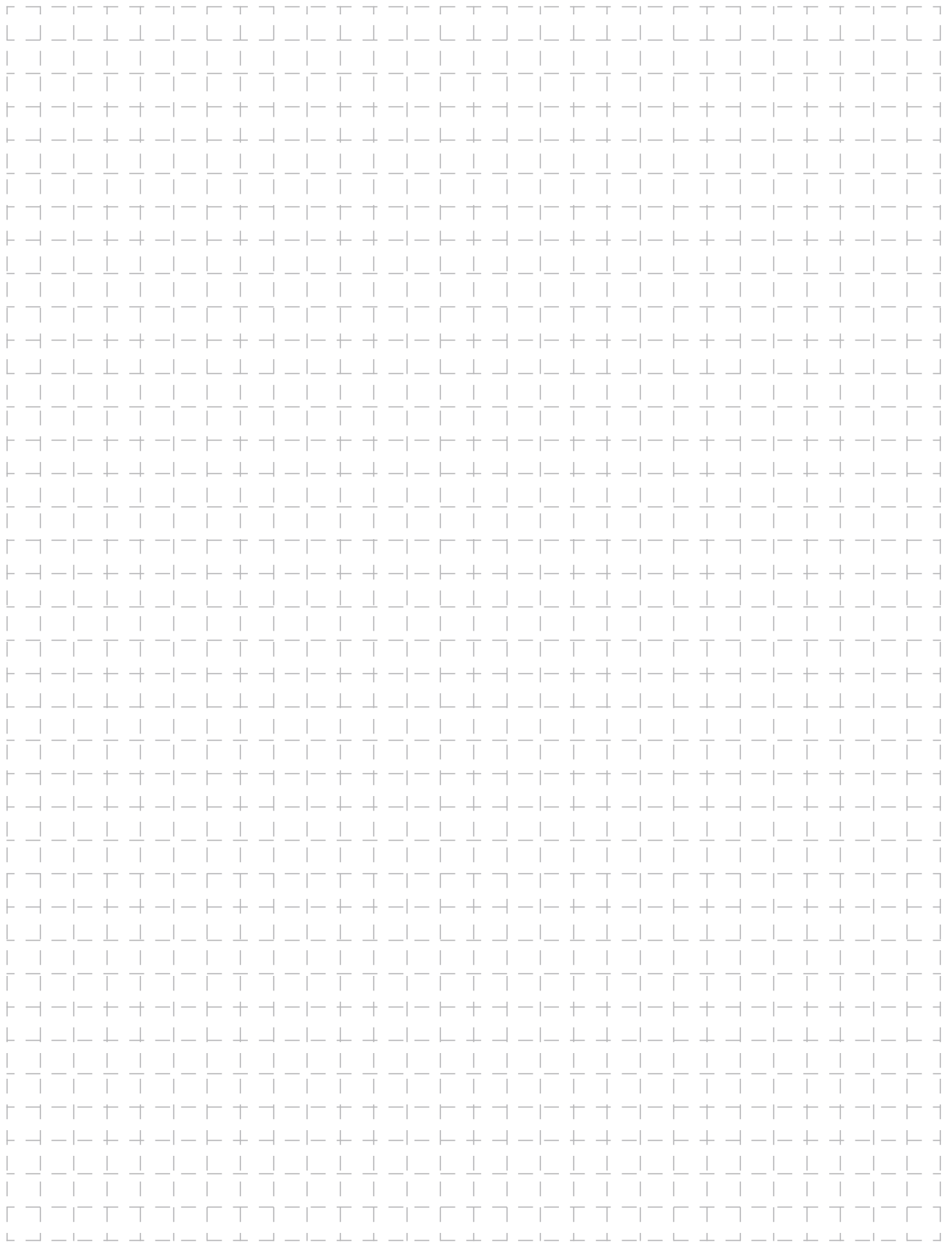

All sales are subject to Omron Electronic Components LLC standard terms and conditions of sale, which can be found at [http://www.components.omron.com/components/web/webfiles.nsf/sales\\_terms.html](http://www.components.omron.com/components/web/webfiles.nsf/sales_terms.html)

**ALL DIMENSIONS SHOWN ARE IN MILLIMETERS.**  
To convert millimeters into inches, multiply by 0.03937. To convert grams into ounces, multiply by 0.03527.

---

**OMRON**<sup>®</sup>  
**OMRON ELECTRONIC  
COMPONENTS LLC**  
**847-882-2288**

**OMRON ON-LINE**

Global - <http://www.omron.com>  
USA - <http://www.components.omron.com>