

TL6210 SERIES TACT SWITCH

ANTI-VANDAL SWITCHES
 DETECTOR SWITCHES
 DIP SWITCHES
 KEYLOCK SWITCHES
 NAVIGATION SWITCHES
 PUSHBUTTON SWITCHES
 ROCKER SWITCHES
 ROTARY SWITCHES
 SLIDE SWITCHES
 SNAP ACTION SWITCHES
TACTILE SWITCHES
 TOGGLE SWITCHES
 CAP OPTIONS



APPLICATIONS / MARKETS



Audio / Visual

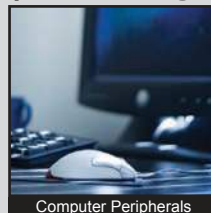

Computer Peripherals



Consumer Electronics



Instrumentation

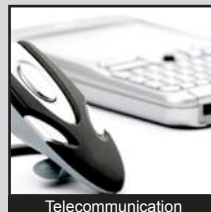

Telecommunication



Medical Equipment

RoHS

SPECIFICATIONS

Electrical Rating: 50mA @ 12VDC
Electrical Life: 100,000 Cycles
Mechanical Life: 100,000 Cycles
Contact Resistance: 500mΩ
Insulation Resistance: 100 MΩ Min. @ 100VDC
Dielectric Strength: 250VAC for 1 min.
Operating Temperature: -20°C to 70°C
Storage Temperature: -20°C to 70°C
Operating Force: 200 +/- 80 gf
Travel: 0.45mm +/- 0.15mm
Contact Arrangement: SPST
Moisture Protection: IP67

FEATURES & BENEFITS

- Surface mount termination
- IP67 rated
- Multiple LED color options
- Small package size

PART NUMBER CONFIGURATOR

Series	Model	Actuator "L" Dimensions	Operating Force	LED Color	Contact Material
<input type="text" value="TL"/>	<input type="text" value="6210"/>	<input type="text" value="A"/>	<input type="text" value="F200 - 200 grams"/>	<input type="text" value="N - None
B - Blue
R - Red
G - Green
Y - Yellow
W - White
X - Red-Green
Z - Green-Yellow"/>	<input type="text" value="Q - Silver"/>

Specifications subject to change without notice



E-SWITCH®

www.e-switch.com

800.867.2717

2

TL6210 SERIES TACT SWITCH

BODY DIMENSIONS

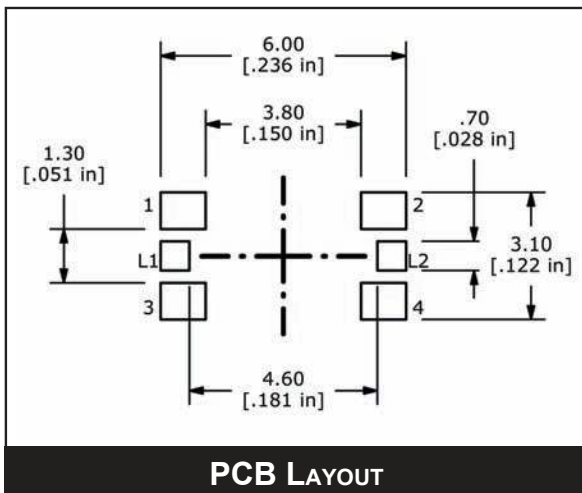
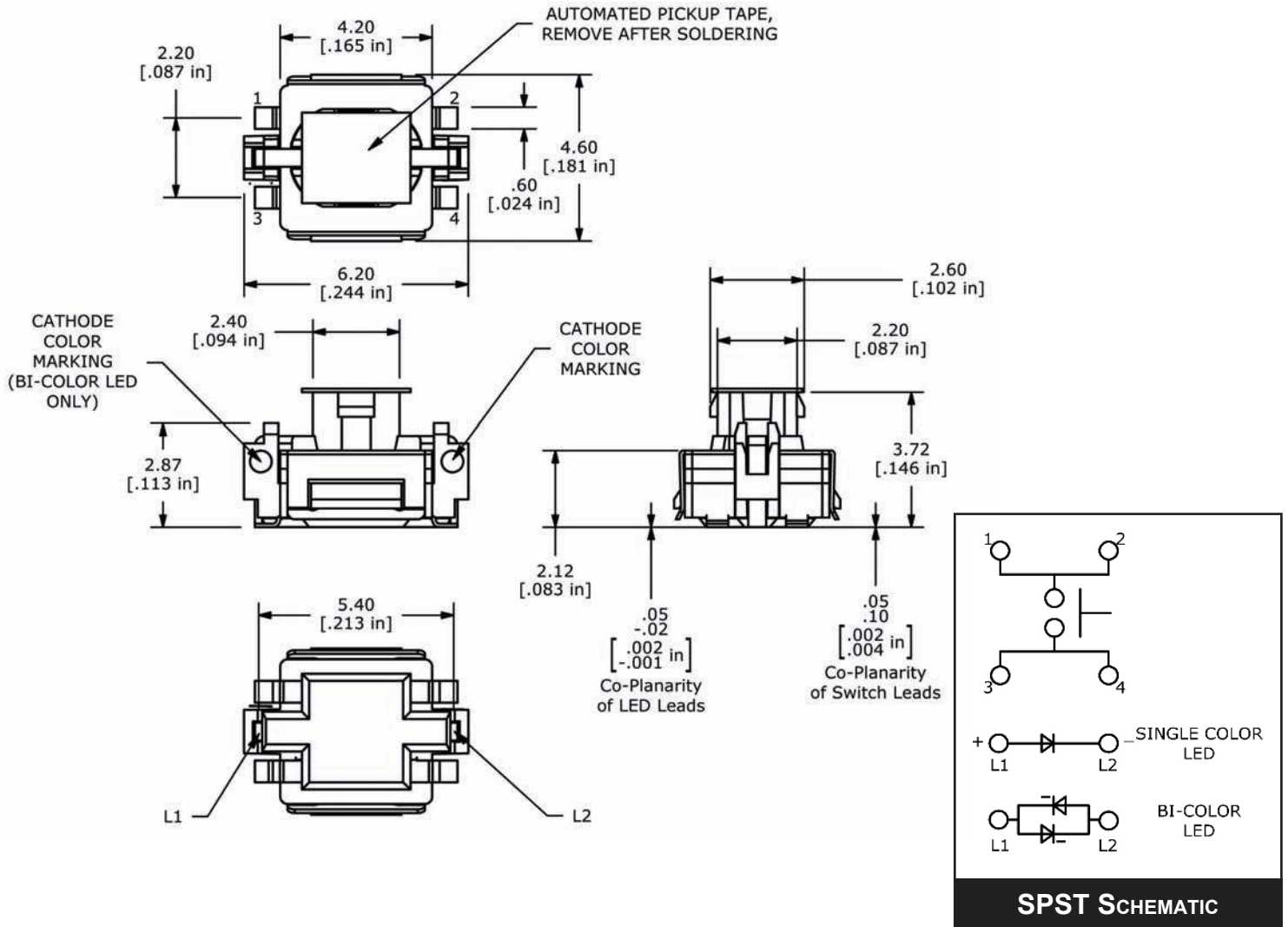

LED Specifications			
LED Color	Forward Current (mA)	Forward Voltage (V @ 20mA)	Luminous Intensity (mcd)
Red	20	1.6 min-1.95 typ	200 typ
Green	20	1.6 min-2.1 typ	50 typ
Yellow	20	1.6 min-2.0 typ	180 typ
Blue	20	2.8 min-3.3 typ	80 typ
White	20	2.8 min-3.3 typ	450 typ
Red-Green BI-Color	20	Red-1.65 min-1.95 typ Green-1.7 min-2.1 typ	Red-200 typ Green-50 typ
Green-Yellow (BI-Color)	20	Green-1.7 min-2.1 typ Yellow-1.6 min-2.0 typ	Green-60 typ Yellow-180 typ

LED SPECIFICATIONS



ANTI-VANDAL SWITCHES
DETECTOR SWITCHES
DIP SWITCHES
KEYLOCK SWITCHES
NAVIGATION SWITCHES
PUSHBUTTON SWITCHES
ROCKER SWITCHES
ROTARY SWITCHES
SLIDE SWITCHES
SNAP ACTION SWITCHES
TACTILE SWITCHES
TOGGLE SWITCHES
CAP OPTIONS