

APPLICABLE TERMINALS & WIRE SIZES			
DESCRIPTION	TE P/N	WIRE SIZE	WIRE SIZE (MM ²)
TERMINAL - FEMALE (Sn)	5-928999-1	20-22 AWG	0.22-0.5
TERMINAL - FEMALE (Sn)	5-963715-1	18 AWG	0.75

REVISIONS					
P.	LTN	DESCRIPTION	DATE	DMN	APVD
A		REV PER ECO-19-015814	17OCT2019	KM	AS

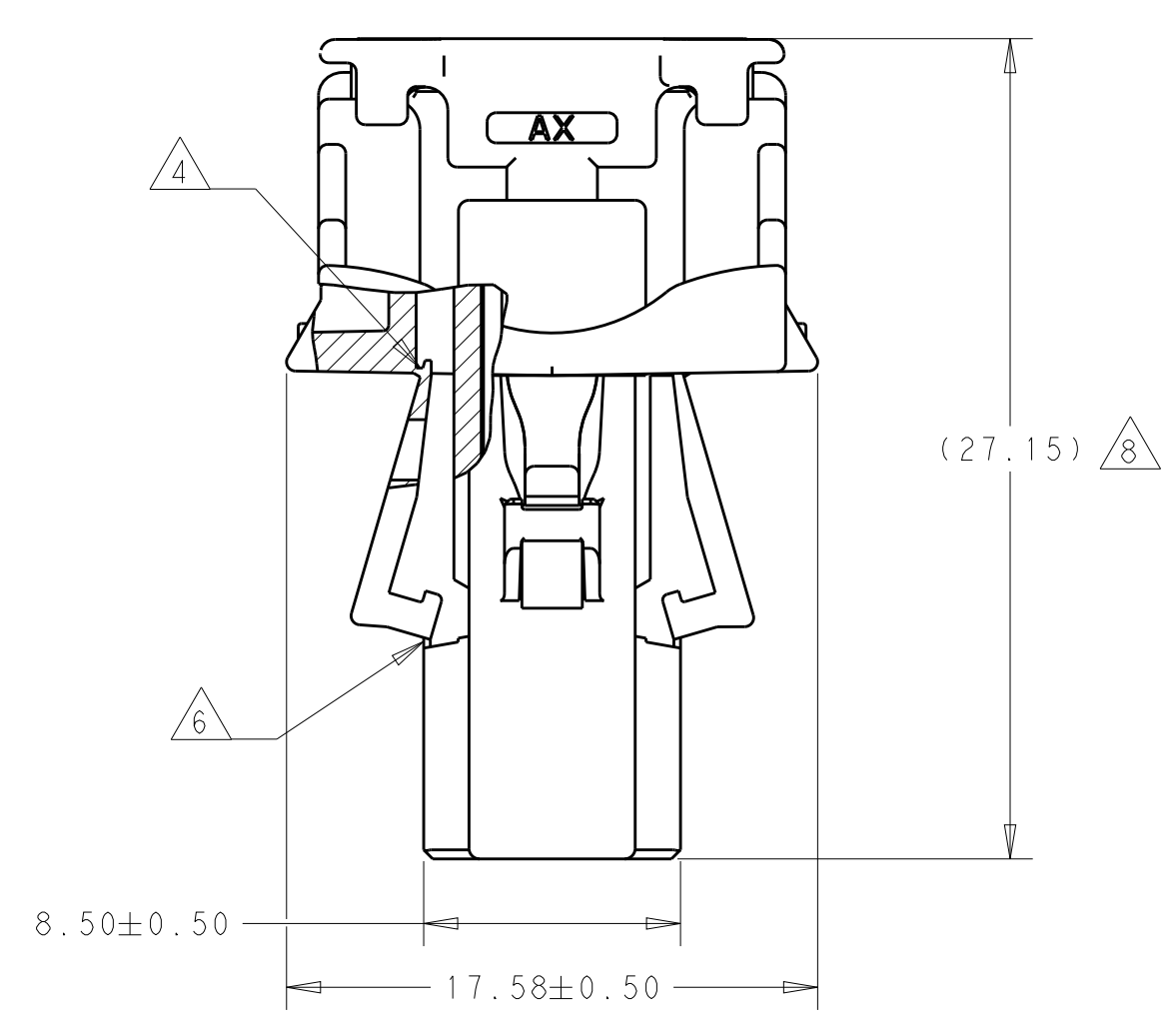

SECTION Y - Y

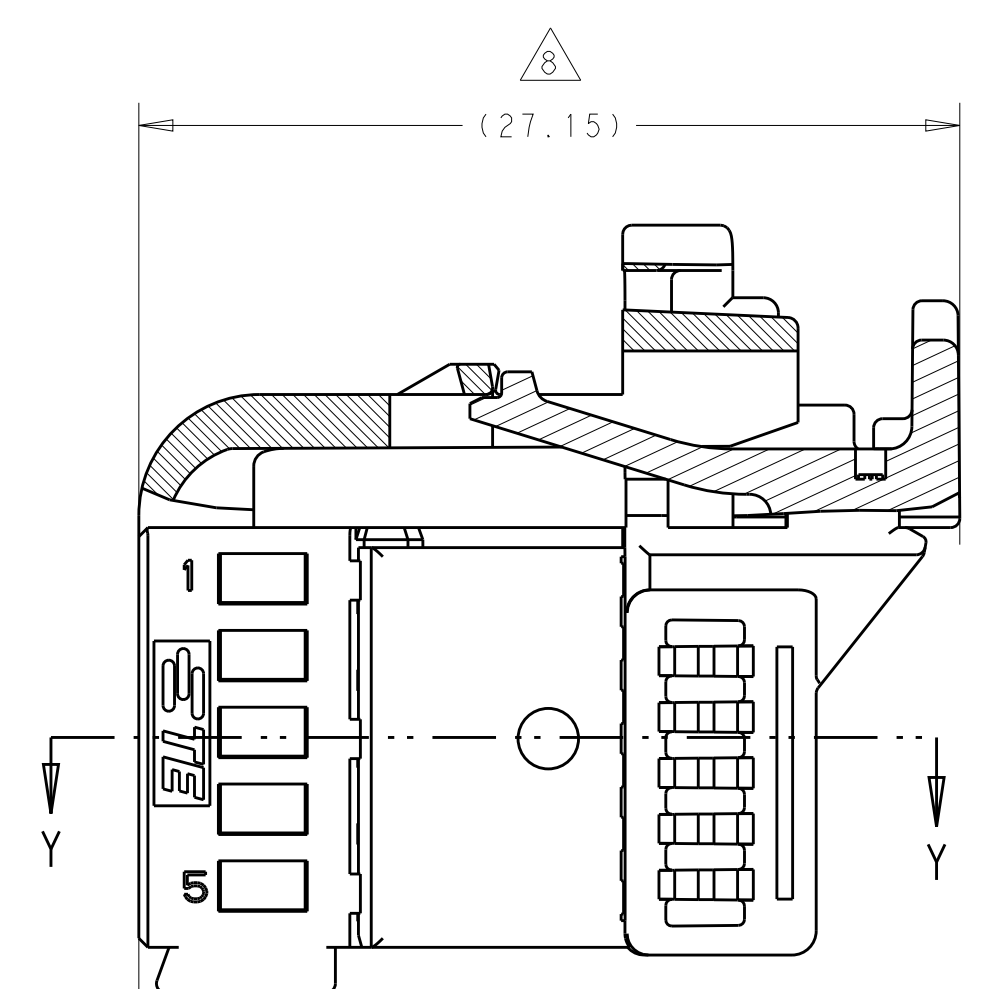
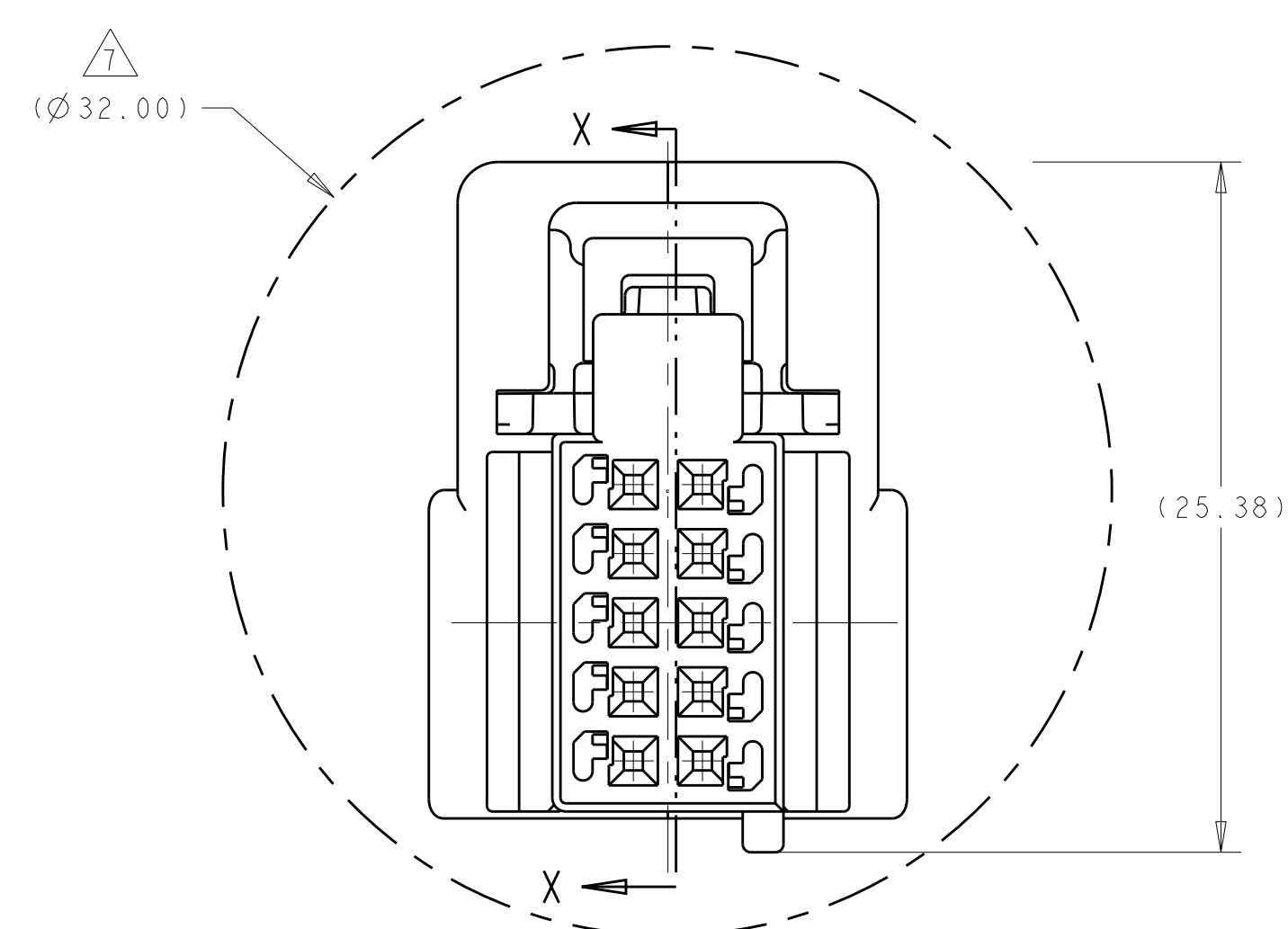

SECTION X - X
CPA SHOWN IN PRE-LOCKED POSITION

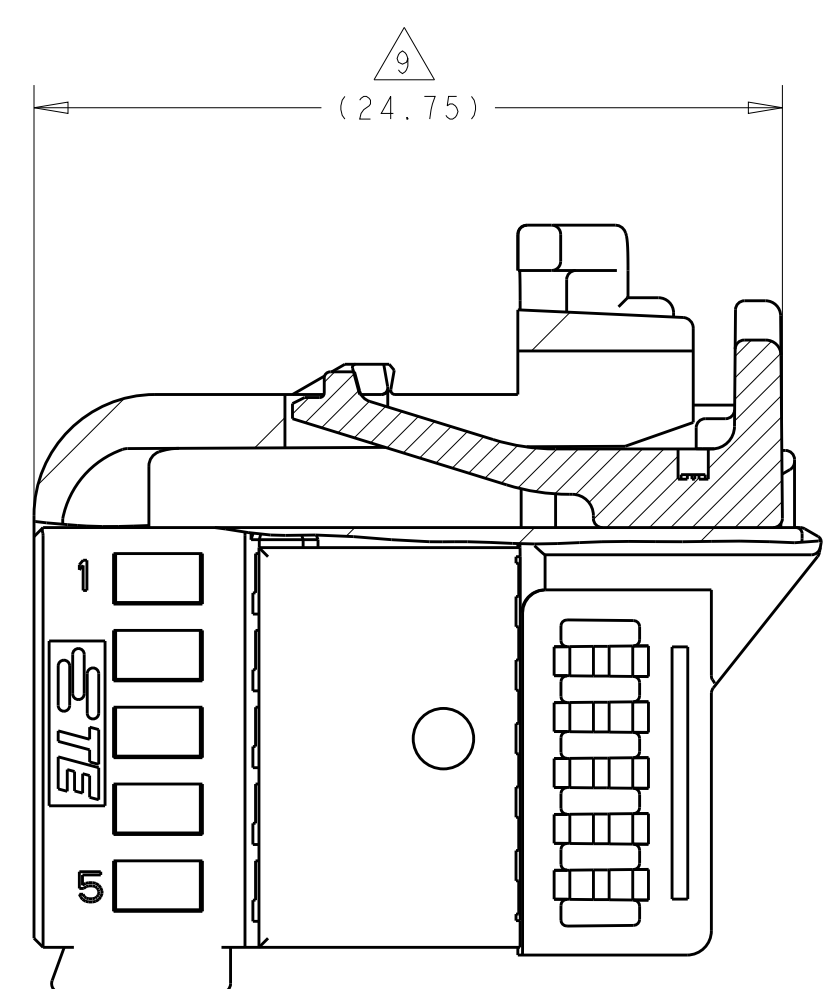

SECTION X - X
CPA SHOWN IN LOCKED POSITION

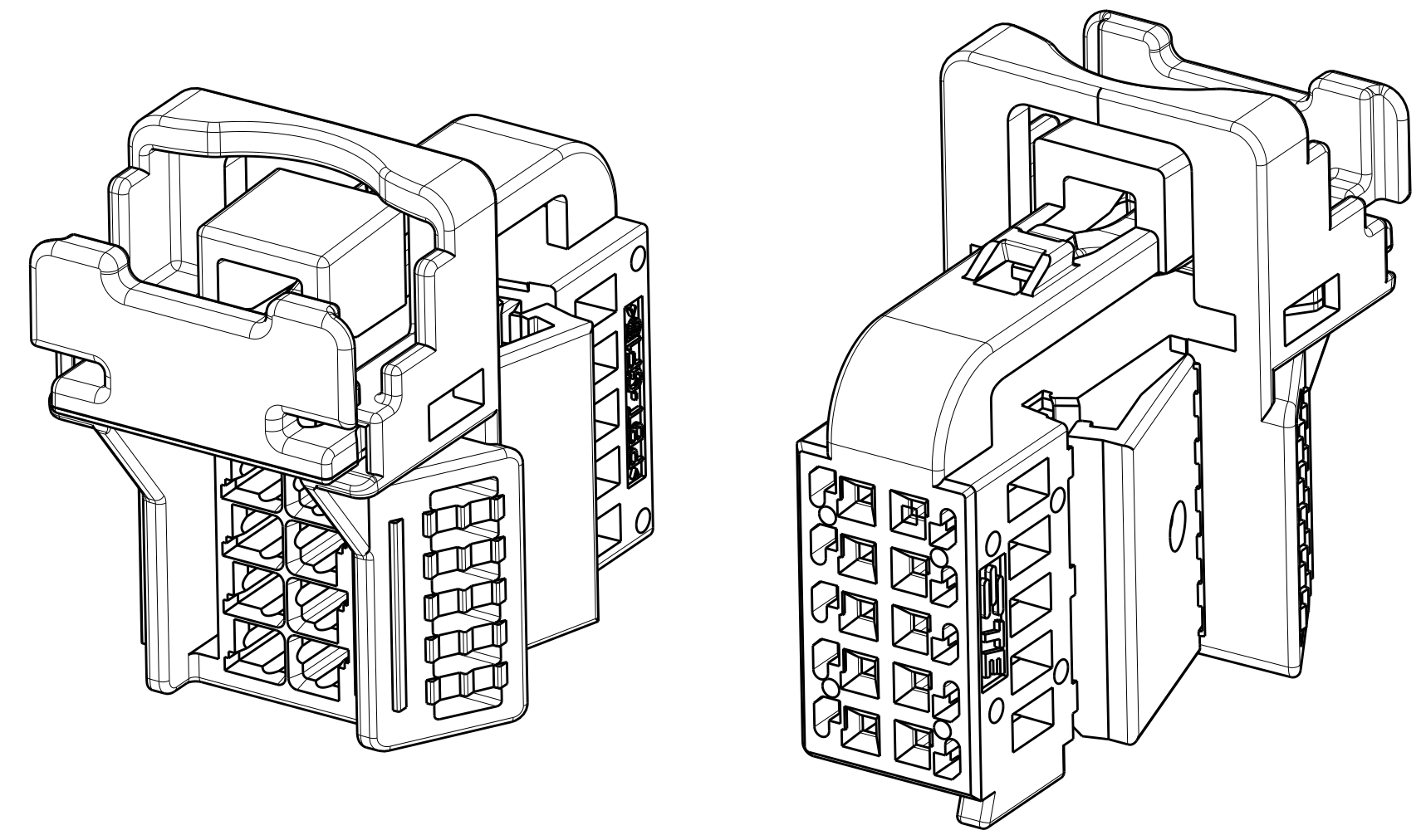

ISOMETRIC VIEW

- 1. MATERIAL: HOUSING-PBT GF15% , CPA-PBT GF30%.
- 2. REFER TO PRODUCT GROUP DRAWING 929454 FOR TERMINAL CONTACT INFORMATION. THIS PLUG WILL NOT WORK WITH TERMINALS DESIGNED FOR INDIVIDUAL WIRE SEALS.
- 3. SEE APPLICATION SPEC.114-13143 FOR TEST PROBE LOCATION LAYOUT.
- 4. WHEN SECONDARY LOCK IS TRANSITIONED FROM THE OPEN TO THE CLOSED POSITION THE PLASTIC ATTACHING THE SECONDARY LOCK IS ALLOWED/ASSUMED TO BREAK AWAY IN THE AREA SHOWN (TYPICAL).
- 5. REFERENCE TE CONNECTIVITY DRAWING NUMBER 2310000-INT FOR MATING INTERFACE DESIGN.
- 6. DURING SHIPPING THESE WEBS MAY BE FRACTURED, AND UP TO 1% OF PARTS MAY HAVE ONE OR BOTH SECONDARY LOCKS IN THE CLOSED POSITION. REFER TO APPLICATION SPEC 114-13143 FOR INSTRUCTION ON USING PARTS IN THIS CONDITION.
- 7. MINIMUM FEED THROUGH HOLE WITH 1MM ALL AROUND.
- 8. CPA (WHEN APPLICABLE) TO BE SHIPPED IN THE PRE-LOCKED POSITION.
- 9. CPA IN FULLY LOCKED CONDITION.
- 10. PART NUMBER 2310000-1 SHOWN ON DRAWING.
- 11. MARK WITH THE ASSEMBLY PART NUMBER AND YEAR, JULIAN DATE CODE, HOUR, MINUTE IN YY JJ HH:MM FORMAT ON GENERAL LOCATION.
- 12. FOR SALABLE PRODUCT MANUFACTURED IN MEXICO THE WORD "MEXICO" MUST BE MARKED ON THE PART PER TEC-115-83

KEY A

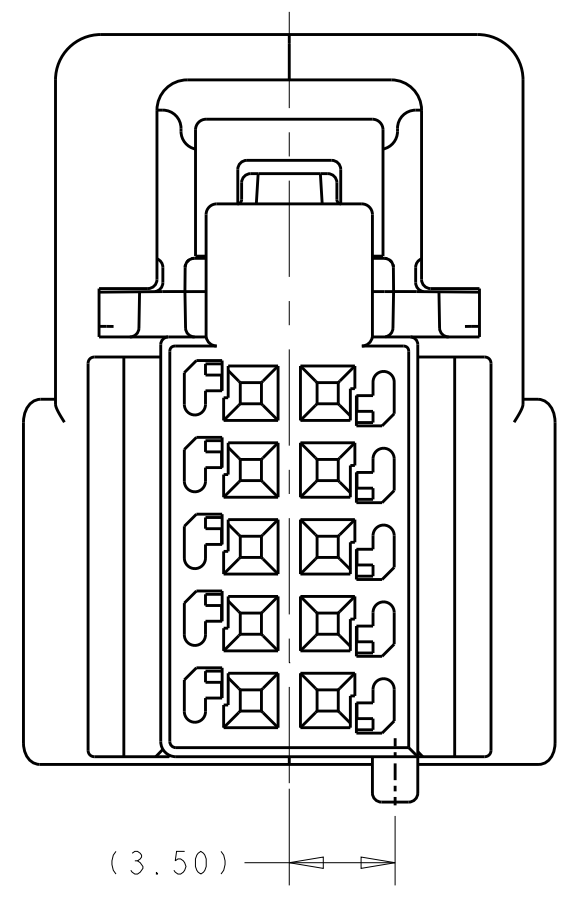

KEY B

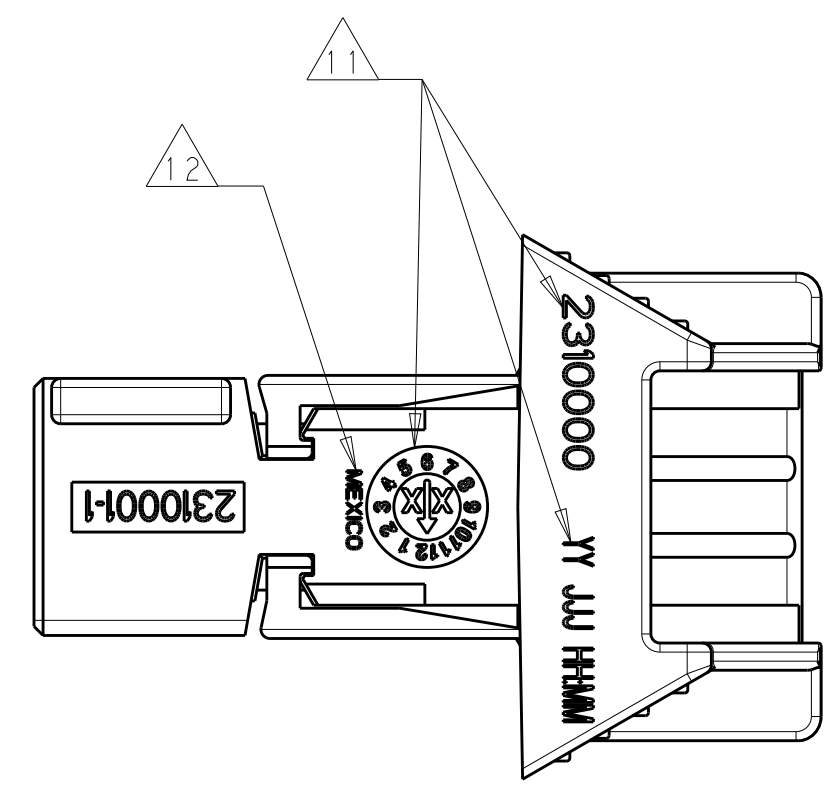
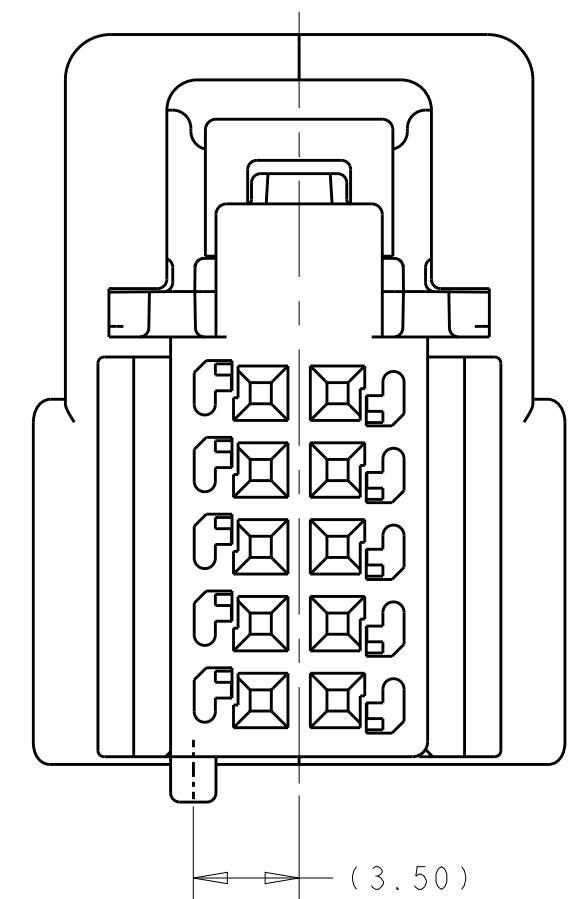

LIGHT GRAY	B	2310000-2
BLACK	A	2310000-1
COLOUR	KEYING	PART NUMBER

THIS DRAWING IS A CONTROLLED DOCUMENT.		DMN	M. BHAVANA	23OCT2017
DIMENSIONS:		CHK	A. STOYANOV	23OCT2017
mm	0 PLC ±	APVD	D. BROWN	23OCT2017
	1 PLC ±	PRODUCT SPEC		
	2 PLC ±0.20	APPLICATION SPEC		
	3 PLC ±	114-13143		
	4 PLC ±	WEIGHT		
	ANGLES ±	CUSTOMER DRAWING		
MATERIAL	FINISH	SCALE 4:1 SHEET 1 OF 1 REV A		



PLUG ASSEMBLY
10 POSITION MOS CONNECTOR

SIZE CAGE CODE DRAWING NO
A100779C=2310000