

LOC	DIST	REVISIONS			
P	LYR	DESCRIPTION	DATE	DWN	APVD
E		RLSE PER NPR 23	10 APR 97	WGL	-
F		REV PER EC 0320-169-97	27 MAY 97	MB	GM
G		REV PER EC 0640-321-98	28 AUG 98	MB	JO
H		REV PER EC 0640-404-98	16 OCT 98	CO	JO

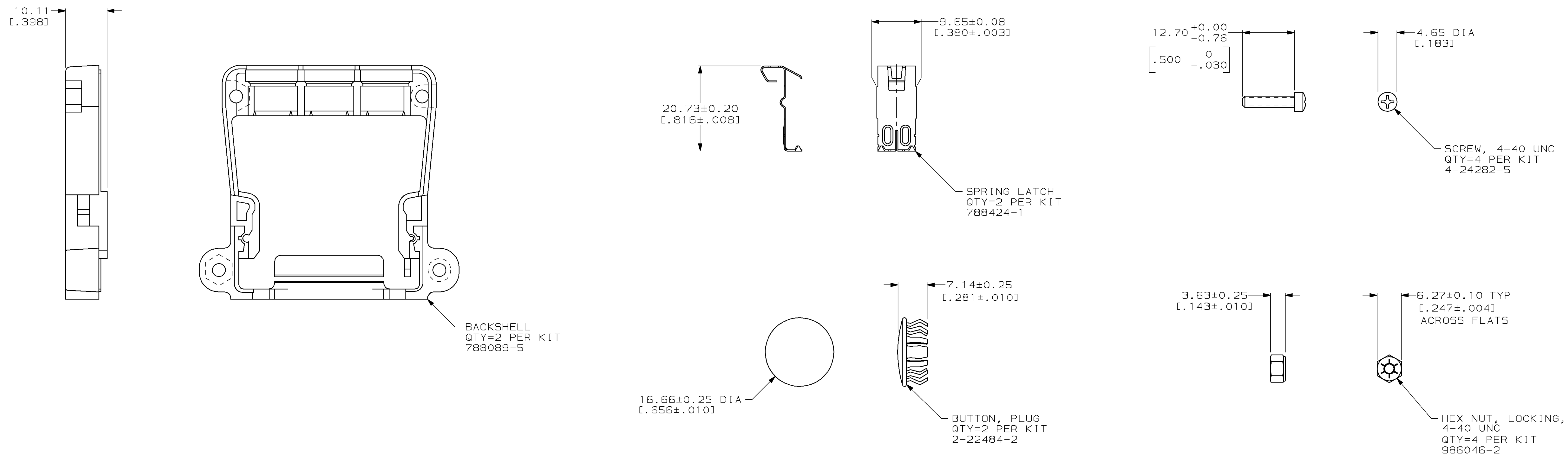

ASSEMBLED VIEWS

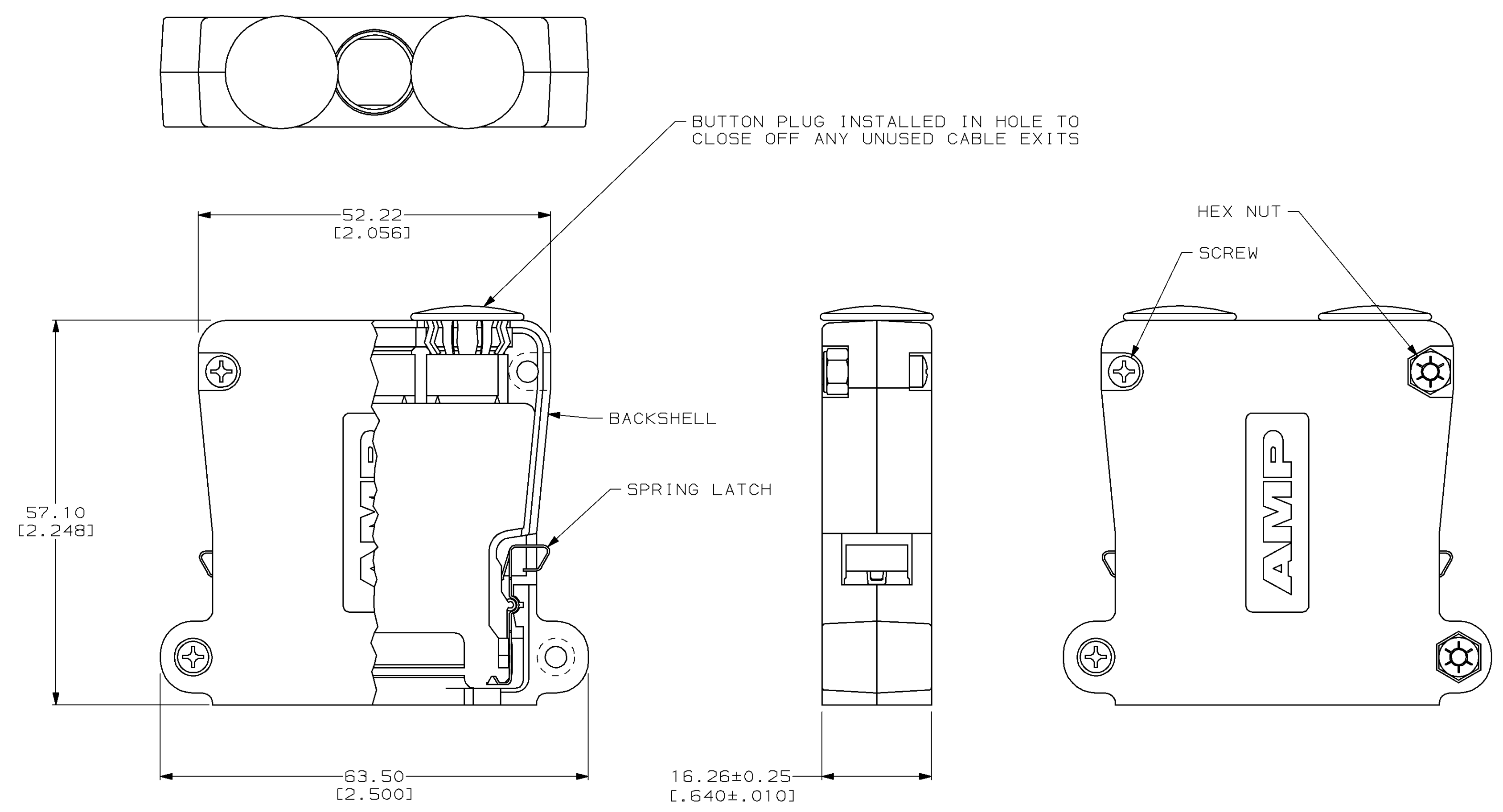

- ① BACKSHELL: ABS, NATURAL.
SPRING LATCH: STAINLESS STEEL, HEAT TREATED.
SCREW, HEX NUT, AND BUTTON: CARBON STEEL.
- ② BACKSHELL: 4.57µm[.000180] MIN NICKEL OVER
7.62µm[.000300] MIN COPPER, ALL OVER 0.25µm[.000010] MIN ELECTROLESS NICKEL.
SCREW AND HEX NUT: ZINC; BUTTON: NICKEL.
- ③ KITS ARE INDIVIDUALLY PACKED.
- ④ KITS ARE BULK PACKED.

④	788070-2
③	788070-1
PART NUMBER	

THIS DRAWING IS A CONTROLLED DOCUMENT.		DWN H. G. LENKER 14 APR 97	03 OCT 96	AMP	AMP Incorporated Harrisburg, PA 17105-3608
DIMENSIONS: mm (INCHES)		CHK R. STONE 14 APR 97	NAME G. D. MILLER		PRODUCT SPEC 108-40032-1
TOLERANCES UNLESS OTHERWISE SPECIFIED:		APPL APPLICATION SPEC		SIZE A1	
0 PLC ±.01		1 PLC ±.01		CAGE CODE 00779	
1 PLC ±.01		2 PLC ±.01		DRAWING NO 788070	
2 PLC ±.01		3 PLC ±.01		WEIGHT -	
3 PLC ±.01		4 PLC ±.01		SCALE 2:1	
4 PLC ±.01		ANGLES ±.01		SHEET 1 OF 1	
FINISH		MATERIAL		REV H	
CUSTOMER DRAWING					