

A1/B1 EB v2.0 User Manual

V1.1
05/10/2017

Table of Contents

1. Device Overview	2
2. Electrical Characteristics	3
2.1 Test Conditions	3
2.2 Absolute Maximum Ratings.....	3
2.3 Operating Conditions.....	3
2.4 GPIO	3
3. Installation and operation	4
3.1 Connecting the RFID A1 module (I2C interface).....	4
3.2 Connecting the RFID B1 module (UART interface)	5
3.3 Connecting the RFID A1 module (SPI interface).....	7
4. Mechanical Dimensions	8

1. Device Overview

The A1/B1 EB v2.0 is an Extension Board (EB) for our RFID modules: the RFID A1 and RFID B1. The user can quickly connect our RFID modules to his device and check functionality and compatibility without wasting time in antenna design and tuning. The A1/B1 EB is simply a board with a built-in PCB antenna where the user can solder our RFID modules and test them. The read range with Mifare 1k ISO card is about 50 mm. All available pins of both modules are placed on the board with descriptions. There is also LED1 (green) which indicates a tag presence in the antenna field.

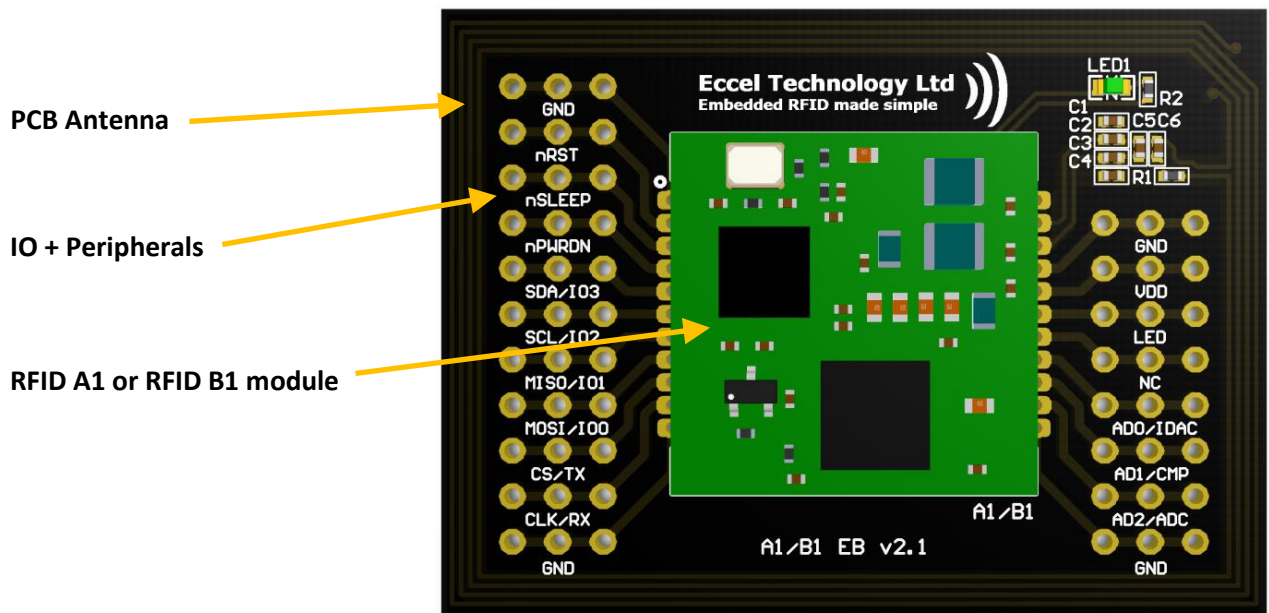

Picture 1-1

2. Electrical Characteristics

2.1 Test Conditions

Typical device parameters were measured at an ambient temperature $22^{\circ}\text{C} \pm 3^{\circ}\text{C}$ and using a power supply of $3.3\text{V} \pm 5\%$.

2.2 Absolute Maximum Ratings

Symbol	Parameter	Min	Max	Unit	Notes
T_S	Storage Temperature	-40	150	$^{\circ}\text{C}$	
V_{DDMAX}	Supply Voltage	0	3.8	V	
V_{IOMAX}	Input Pin Voltage	-0.3	$V_{DD} + 0.3$	V	
I_{IOMAX}	Output Pin Current	0	6	mA	
I_{ANT}	ANT1 and ANT2 Current	0	100	mA	Maximum continuous current. This depends upon the impedance of the circuit between ANT1 and ANT2 at 13.56MHz.

Table 2-1

2.3 Operating Conditions

Symbol	Parameter	Min	Max	Unit
T_O	Ambient Temperature	-25	85	$^{\circ}\text{C}$
V_{DD}	Supply Voltage	2.5	3.6	V

Table 2-2

2.4 GPIO

Symbol	Parameter	Min	Typ	Max	Unit	Notes
V_{IOIL}	Input Low Voltage			$0.3V_{DD}$	V	
V_{IOIH}	Input High Voltage	$0.7V_{DD}$			V	
I_{IOMAX}	Output Pin Current			± 6	mA	
I_{IOLEAK}	Input Leakage Current		± 0.1	± 40	nA	High impedance IO connected to V_{3V3} or GND.
R_{IOESD}	Internal ESD Series Resistor		200		Ω	
V_{IOHYST}	IO Pin Hysteresis	$0.1V_{DD}$			V	

Table 2-3

3. Installation and operation

3.1 Connecting the RFID A1 module (I2C interface)

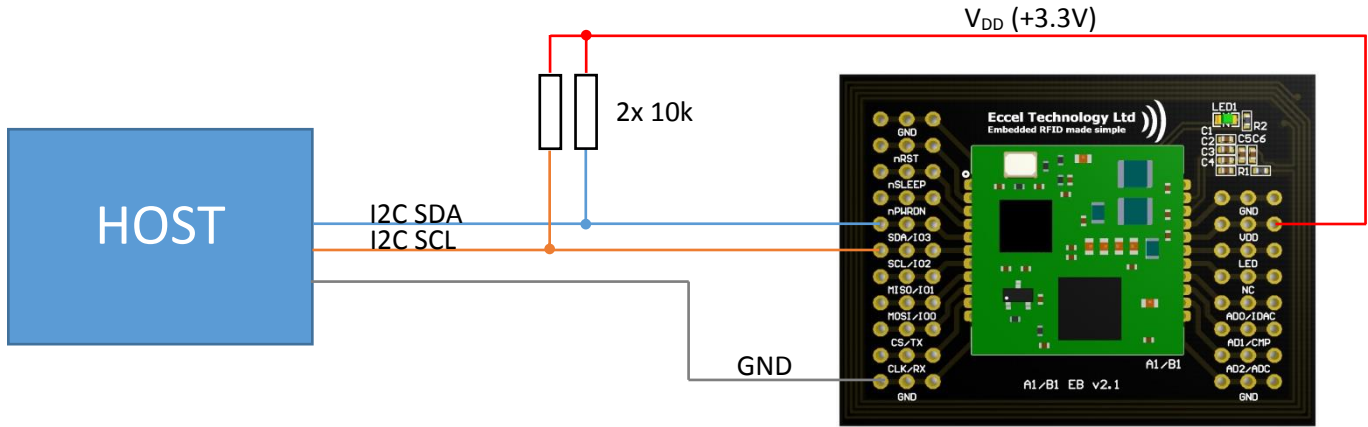
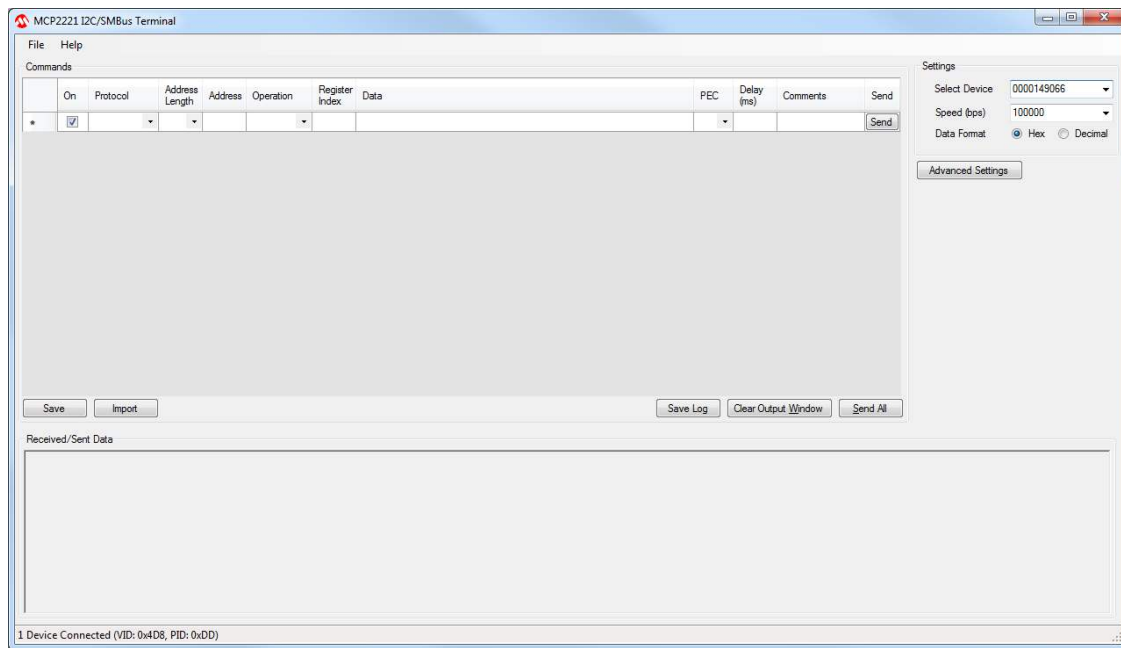

Figure 3-1 Minimum configuration of the I2C connection

The main window of the MCP2221 I2C/SMBus Terminal software is presented below. If the A1 module is properly fitted and all connections are correct, the user can start testing the RFID A1 module.



To get the Tag UID and type, the user should send 0x01 command (the Get UID and Type command has value 0x01) to the address 0x0001 (Command Register is located at address 0x0001) and then read the A1 memory, for example 255 bits (0xFF). The full A1 memory contains 728 bits (0x02D8). It is necessary to create two lines of commands: one to write the A1 command “Get UID and Type” and the other one to read the memory. A correctly read tag UID is shown below.

3.3 Connecting the RFID A1 module (SPI interface)

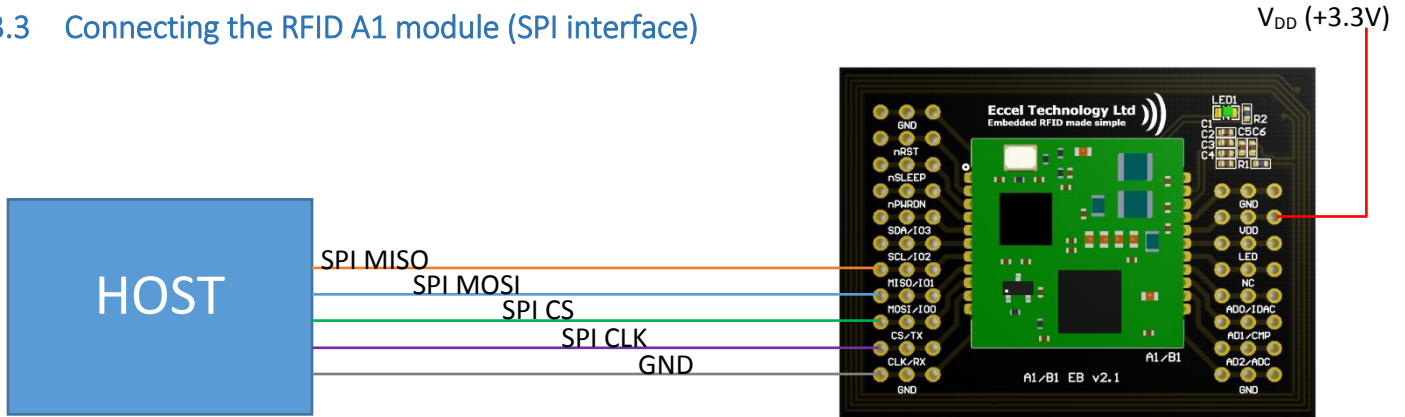
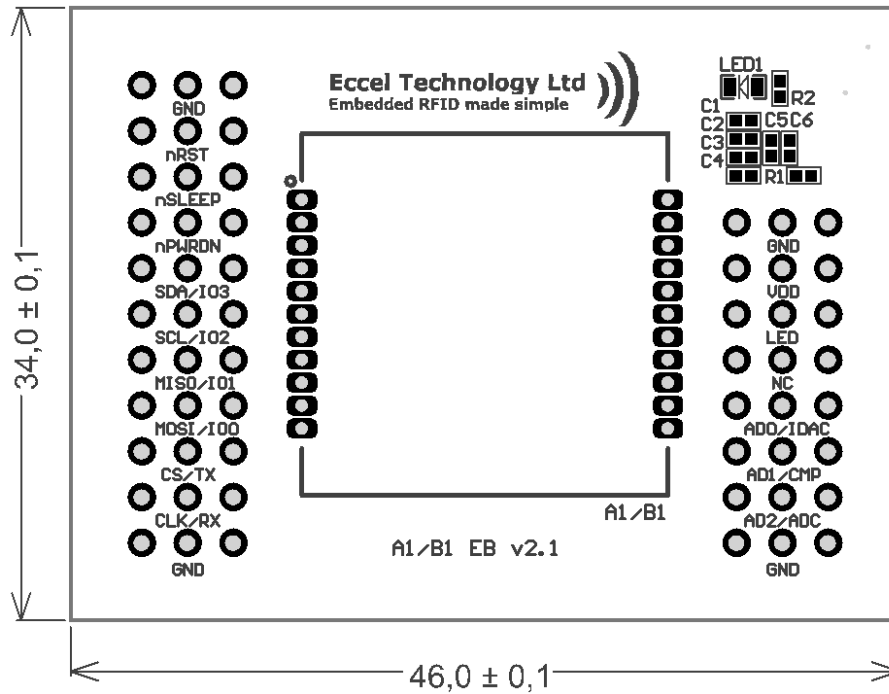

Figure 3-5 Minimum configuration of the SPI connection

The user can use the [FT232H Mini-Module](#) (FTDI) which is a USB to dual channel serial interface converter based on the FT232H USB Hi-Speed IC or similar to quickly test the SPI connection. After that the RFID A1 or B1 module can be tested with the B1 Client as described above.

4. Mechanical Dimensions

Dimensions in mm. Pin pitch is 2.54 mm.



No responsibility is taken for the method of integration or final use of the B1 based modules

More information about the B1 module and other products can be found at the Internet site:

www.eccel.co.uk

or alternatively contact ECCEL Technology (IB Technology) by e-mail at:

sales@eccel.co.uk