

THE INFORMATION CONTAINED HEREIN IS CONSIDERED "PROPRIETARY" TO BEL FUSE INC. AND SHALL NOT BE COPIED, REPRODUCED OR DISCLOSED WITHOUT THE WRITTEN APPROVAL OF BEL FUSE INC.

RoHS



ELECTRICAL CHARACTERISTICS @ 25°C

<p> URNS RATIO TX 1CT : 1 RX 1CT : 1 QCL @ 100kHz/100mVRMS 8mA DC BIAS 350µH MIN. INS. LOSS 1MHz TO 100MHz -1.0 dB MAX RET. LOSS (MIN) 1MHz-30MHz -18 dB 30MHz-60MHz $-18+20\text{LOG}(F/30\text{MHz})$ dB 60MHz-80MHz -12 dB CROSS TALK (TX - RX) 500kHz-1MHz -70 dB MIN 10 MHz -50 dB MIN 30 MHz -45 dB MIN 50 MHz -40 dB MIN 100 MHz -35 dB MIN CM TO CM REJ 100kHz-1MHz -70 dB MIN 10 MHz -47 dB MIN 30 MHz -42 dB MIN 60 MHz -37 dB MIN 100 MHz -30 dB MIN CM TO DM REJ 100kHz-1MHz -70 dB MIN 10 MHz -60 dB MIN 30 MHz -50 dB MIN 60 MHz -45 dB MIN 100 MHz -40 dB MIN </p>	
---	--

HIPOT (Isolation Voltage): 1500 Vrms or 2250VDC
 100% OF PRODUCTION TESTED TO COMPLY WITH IEEE 802.3 ISOLATION REQUIREMENTS.
 OPERATING TEMPERATURE: 0°C TO +70°C.

SCHEMATIC

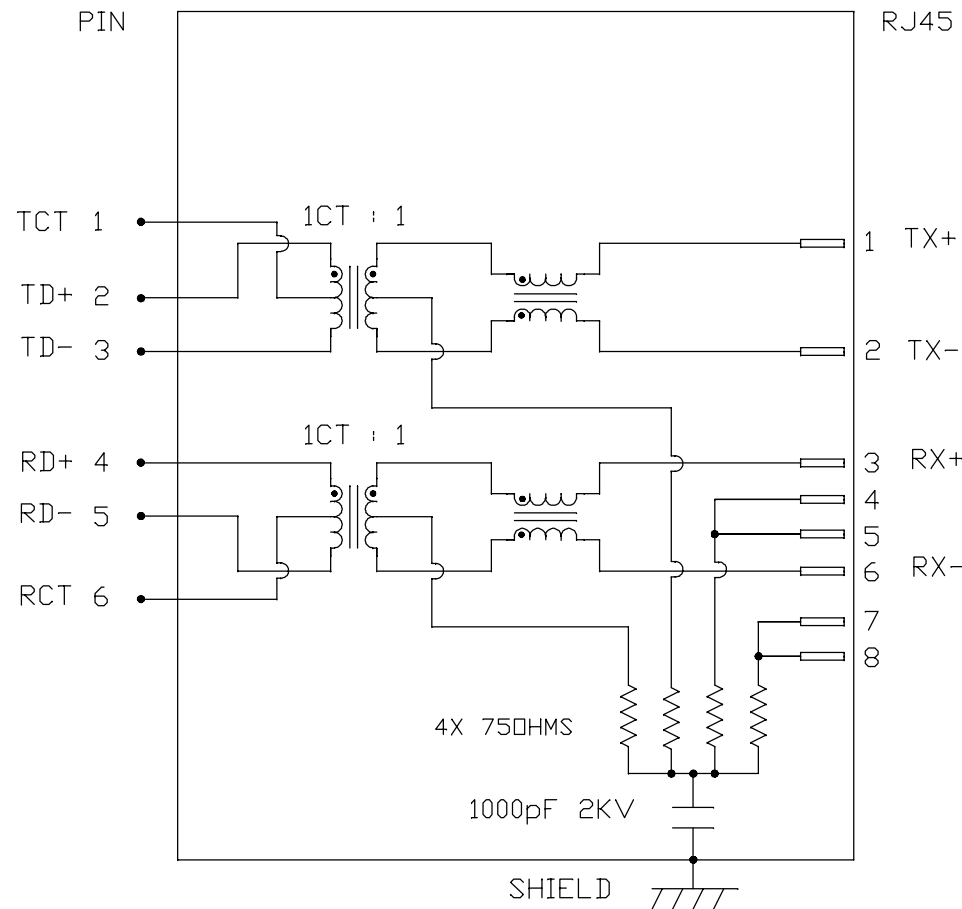

ORIGINATED BY
 CHOW WANCHUNG
DATE 2017-03-10
DRAWN BY
 LI LINFENG
DATE 2017-03-10

TITLE
 SMD MagJack®
 (< 4 Cores, MDIX, CM Termination)
 S811-1X1T-06-F

PART NO. / DRAWING NO.
 S811X1T06-F
FILE NAME
 S811X1T06-F_G.DWG

STANDARD DIM.	[] METRIC DIM.
TOL. IN INCH	AS REF.
.X	UNIT : INCH [mm]
.XX	SCALE : N/A
.XXX	SIZE : A4

REV. : G	PAGE : 2

THE INFORMATION CONTAINED HEREIN IS CONSIDERED "PROPRIETARY" TO BEL FUSE INC. AND SHALL NOT BE COPIED, REPRODUCED OR DISCLOSED WITHOUT THE WRITTEN APPROVAL OF BEL FUSE INC.

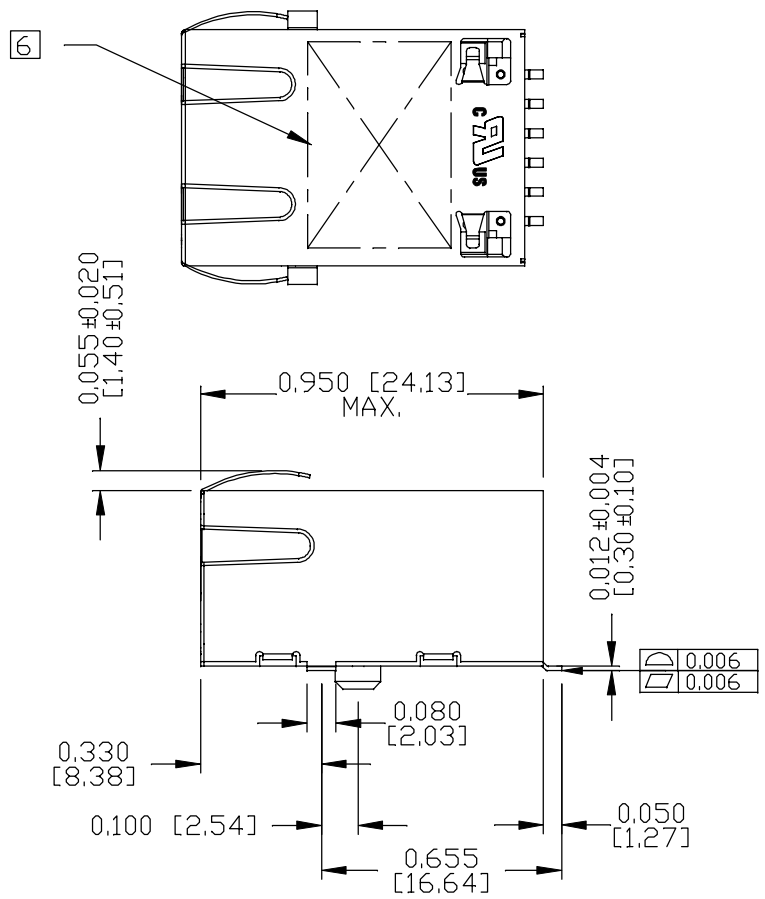
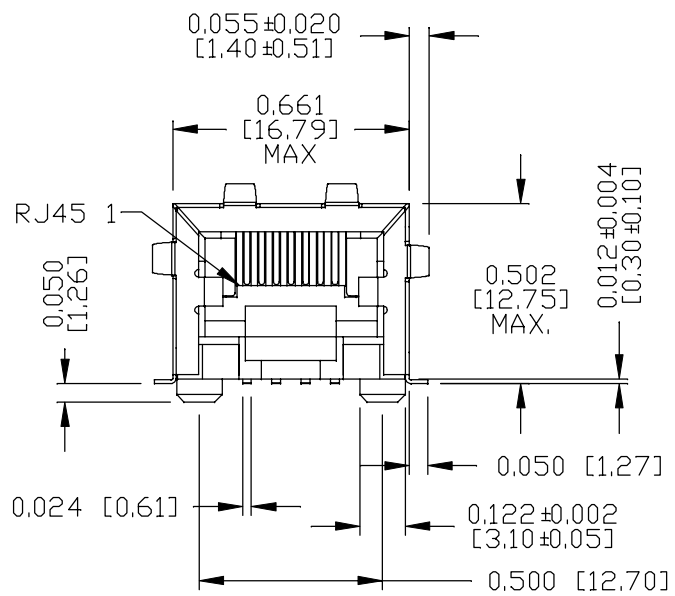

NOTES:

1. PLASTIC HOUSING: THERMOPLASTIC PA & THERMOSET PHENOLIC. BLACK FLAMMABILITY RATING UL 94V-0
2. CONTACTS PLATING: 50 MICRO-INCH HARD GOLD PLATING OR EQUIVALENT.
3. PINS: TIN-COATED COPPER WIRE, 0.024 [0.6] X 0.012 [0.3] THK. 100 MICRO-INCH MIN MATTE TIN. PINS ARE SOLDER DIPPED.
4. METAL SHIELD: NICKEL PLATED COPPER ALLOY.
5. JACK CAVITY CONFORMS TO FCC RULES AND REGULATIONS.
6. MARK PART WITH MFG. LOGO, MFG. NAME, PART NUMBER AND DATE CODE.

7. THE PRODUCT IS RoHS COMPLIANT.
8. THE PART IS RECOMMENDED FOR WAVE SOLDERING. THE SUGGESTED PEAK WAVE SOLDERING CONDITION IS 260°C MAX AND 10 SECONDS MAX.



UL RECOGNIZED - FILE #E196366 AND E169987.

ORIGINATED BY SANDY LIN DATE 2017-03-10		TITLE SMD MagJack® (4 Cores,MDIX,CM Termination)		PART NO. / DRAWING NO. S8111X1T06-F		STANDARD DIM. TOL. IN INCH .X .XX .XXX ±0.010		[] METRIC DIM. AS REF. UNIT : INCH [mm] SCALE : N/A SIZE : A4		REV. : G	PAGE : 3
DRAWN BY XUE RIPING DATE 2017-03-10		FILE NAME S811-1X1T-06-F						bel MAGNETIC SOLUTIONS a bel group			

THE INFORMATION CONTAINED HEREIN IS CONSIDERED "PROPRIETARY" TO BEL FUSE INC. AND SHALL NOT BE COPIED, REPRODUCED OR DISCLOSED WITHOUT THE WRITTEN APPROVAL OF BEL FUSE INC.



RECOMMENDED PCB FOOTPRINT
COMPONENT SIDE VIEW

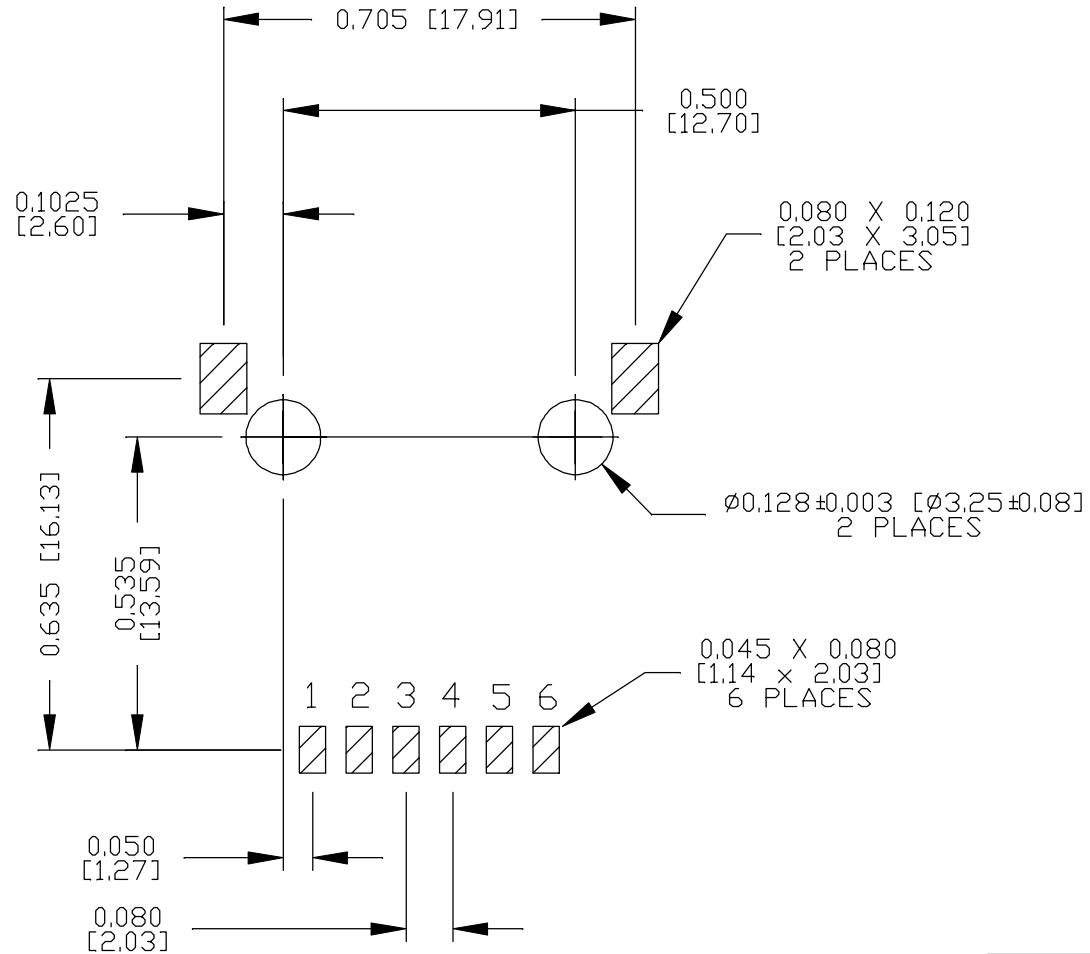

ORIGINATED BY
SANDY LIN
DATE 2017-03-10
DRAWN BY
XUE RIPING
DATE 2017-03-10

TITLE
SMD MagJack ®
(4 Cores, MDIX, CM Termination)
S811-1X1T-06-F

PART NO. / DRAWING NO.
S811X1T06-F
FILE NAME
S811X1T06-F_G.DWG

STANDARD DIM. TOL. IN INCH	[] METRIC DIM. AS REF.
.X	UNIT : INCH [mm]
.XX	SCALE : N/A
.XXX	±0.004
	SIZE : A4

REV. : G PAGE : 4



THE INFORMATION CONTAINED HEREIN IS CONSIDERED "PROPRIETARY" TO BEL FUSE INC. AND SHALL NOT BE COPIED, REPRODUCED OR DISCLOSED WITHOUT THE WRITTEN APPROVAL OF BEL FUSE INC.

RoHS



SUGGESTED PANEL OPENING

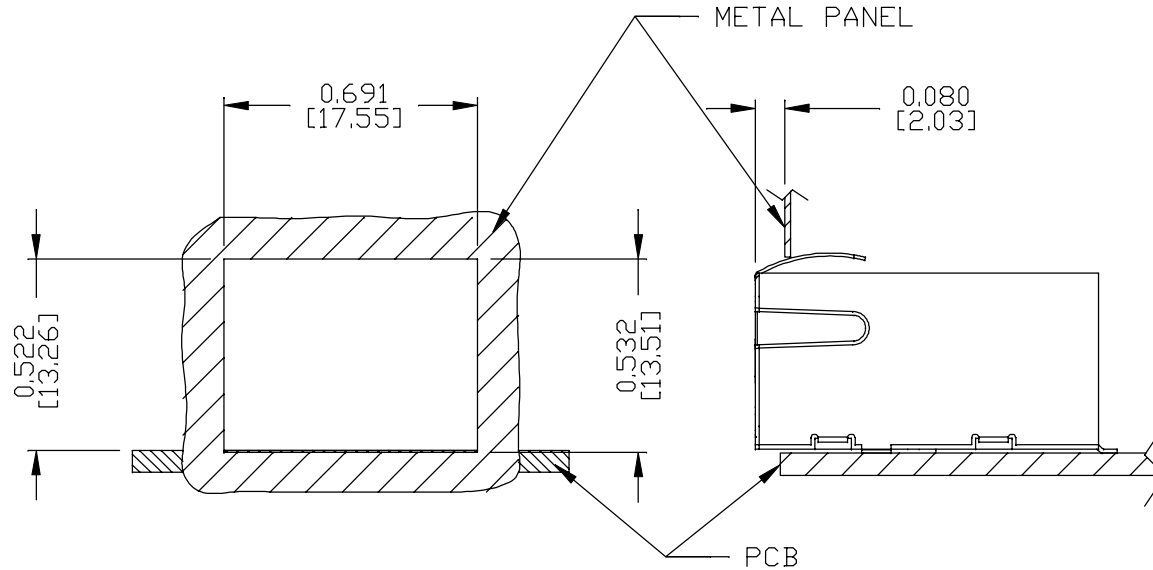

NOTES:

THE DISTANCE OF PANEL INSIDE SURFACE RELATIVE TO FRONT SURFACE OF PART IS ONLY A SUGGESTION. IN CASE THIS DISTANCE IS DIFFERENT, THE REQUIRED PANEL OPENING DIMENSIONS CHANGE ACCORDINGLY.

REV. : G PAGE : 5

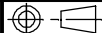
ORIGINATED BY SANDY LIN DATE 2017-03-10	TITLE SMD MagJack® (4 Cores,MDIX,CM Termination) S811-1X1T-06-F	PART NO. / DRAWING NO. S8111X1T06-F	STANDARD DIM. TOL. IN INCH	[] METRIC DIM. AS REF.	
DRAWN BY XUE RIPING DATE 2017-03-10		FILE NAME S8111X1T06-F_G.DWG	.X	UNIT : INCH [mm]	
			.XX	SCALE : N/A	
			.XXX ±0.004	 SIZE : A4	

THE INFORMATION CONTAINED HEREIN IS CONSIDERED "PROPRIETARY" TO BEL FUSE INC. AND SHALL NOT BE COPIED, REPRODUCED OR DISCLOSED WITHOUT THE WRITTEN APPROVAL OF BEL FUSE INC.

RoHS

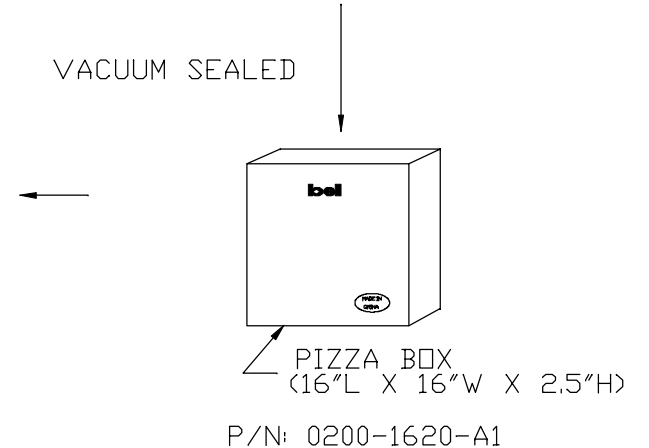
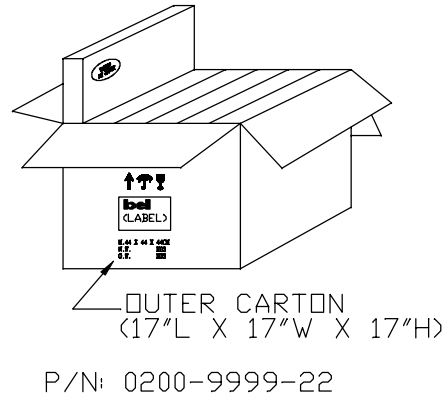
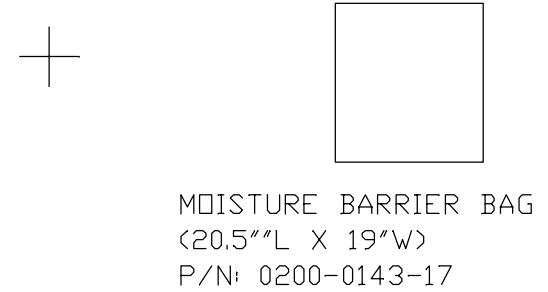
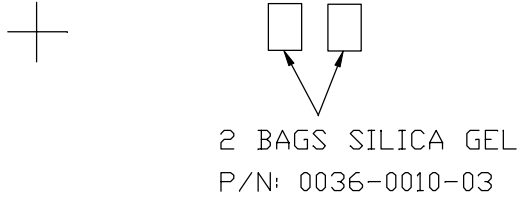

NOTES:

- 1) LEAVES 48 INCHES COVER TAPE AND 5 EMPTY POCKETS AT TRAILER.
- 2) LEAVES 24 INCHES COVER TAPE AND 13 EMPTY POCKETS AT LEADER.
- 3) PACK 175 PCS PER REEL.
- 4) EACH BAGS SHOULD HAVE TWO BAGS SILICA GEL INSIDE MOISTURE BARRIER BAG. & VACUUM SEALED
- 5) EACH PIZZA BOX CONTAINS ONE (1) MOISTURE BARRIER BAG. (175 PCS FINISHED GOODS EACH PIZZA BOX).
- 6) EACH OUTER CARTON CONTAINS SIX (6) PIZZA BOXES. (1050 PCS FINISHED GOODS EACH OUTER CARTON).

USER FEED DIRECTION

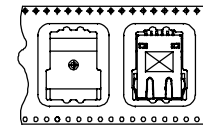

PART ORIENTATION & FEEDING DIRECTION.

REV. :	G	PAGE :	6
--------	---	--------	---

ORIGINATED BY SANDY LIN DATE 2017-03-10	TITLE SMD MagJack® (4 Cores,MDIX,CM Termination)	PART NO. / DRAWING NO. S8111X1T06-F	STANDARD DIM. [] METRIC DIM.	
			TOL. IN INCH	AS REF.
DRAWN BY XUE RIPING DATE 2017-03-10	S811-1X1T-06-F	FILE NAME S8111X1T06-F_G.DWG	.X	UNIT : INCH [mm]
			.XX	SCALE : N/A
			.XXX	SIZE : A4



THE INFORMATION CONTAINED HEREIN IS CONSIDERED "PROPRIETARY" TO BEL FUSE INC. AND SHALL NOT BE COPIED, REPRODUCED OR DISCLOSED WITHOUT THE WRITTEN APPROVAL OF BEL FUSE INC.

RoHS

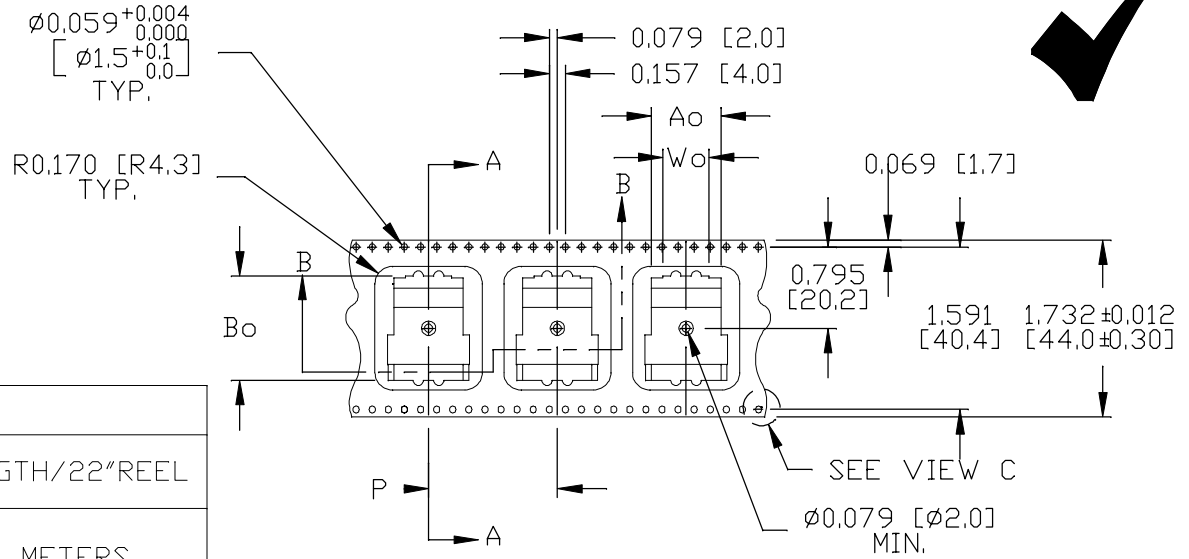
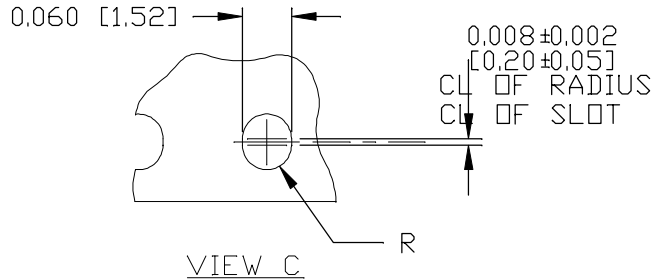

DIMENSION CHART

PART NUMBER	Ao	Bo	Ko	P	Wo	T	LENGTH/22" REEL
N220-0405-46	0.670 [17.02]	1.010 [25.65]	0.635 [16.13]	1.260 [32.00]	0.505 [12.83]	0.020 [0.50]	13 METERS

NOTES :

- ALL OTHER SPECIFICATIONS SHOULD MEET EIA 481-D STANDARD.

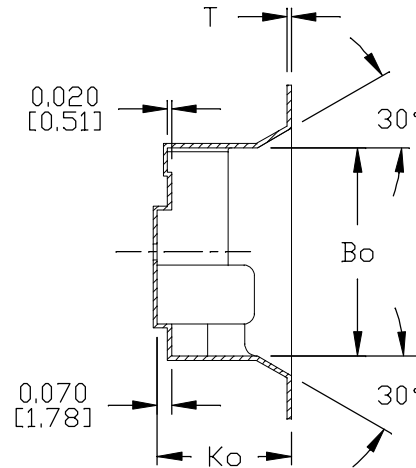

SECTION A-A

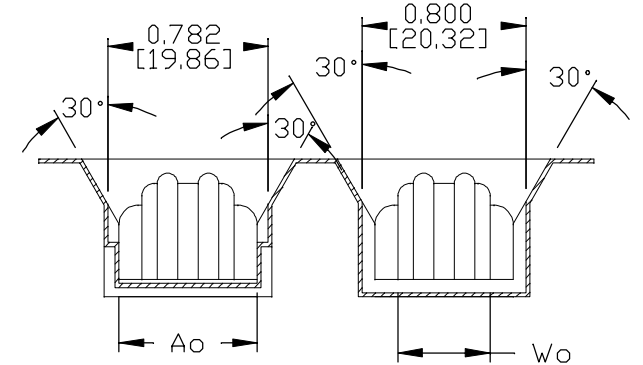

SECTION B-B

REV. : G PAGE : 7

ORIGINATED BY
SANDY LIN
DATE 2017-03-10
DRAWN BY
XUE RIPING
DATE 2017-03-10

TITLE
SMD MagJack®
(4 Cores, MDIX, CM Termination)
S811-1X1T-06-F

PART NO. / DRAWING NO.
S8111X1T06-F
FILE NAME
S8111X1T06-F_G.DWG

STANDARD DIM. TOL. IN INCH
[] METRIC DIM. AS REF.
.X UNIT : INCH [mm]
.XX SCALE : N/A
.XXX SIZE : A4



THE INFORMATION CONTAINED HEREIN IS CONSIDERED "PROPRIETARY" TO BEL FUSE INC. AND SHALL NOT BE COPIED, REPRODUCED OR DISCLOSED WITHOUT THE WRITTEN APPROVAL OF BEL FUSE INC.

RoHS



MOISTURE BARRIER BAG

OPEN HERE

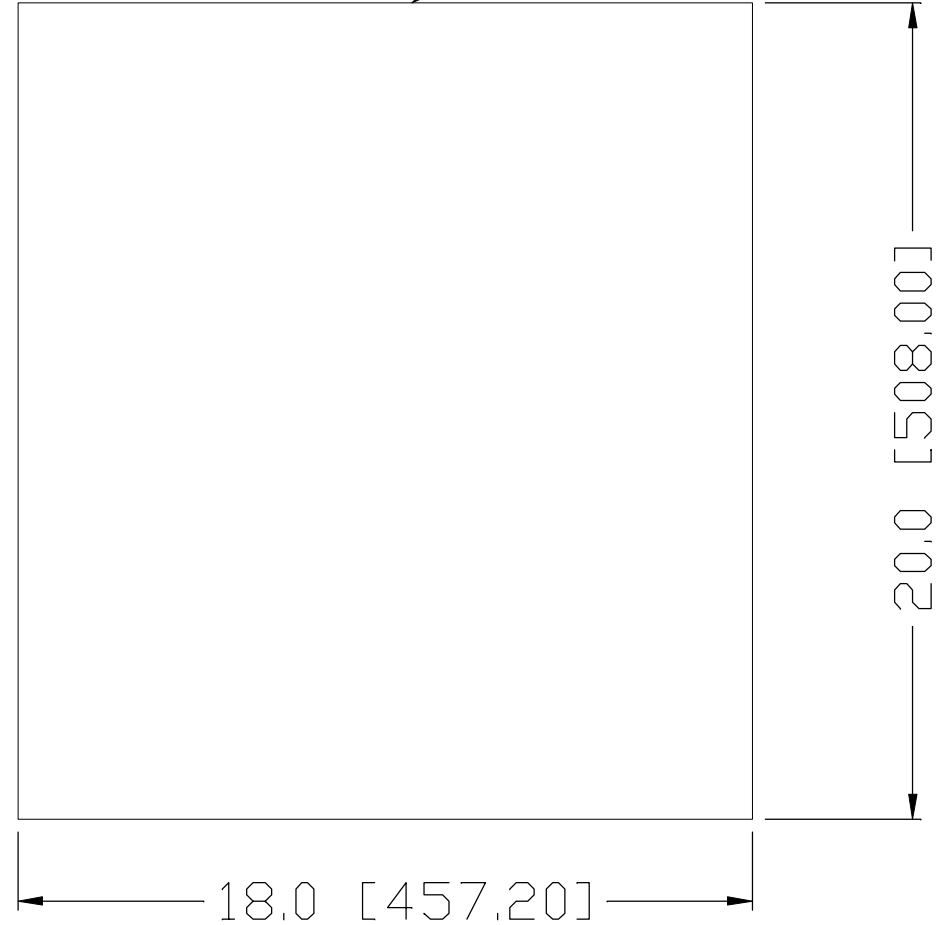

NOTES:

1. MATERIAL : BI-LAYER LALMINATED MATERIAL CONTAINS NYLON & POLYETHYLENE.
2. MATERIAL THICKNESS : 0.003±0.0008".
3. COLOR : TRANSPARENT.
4. ALL DIMENSIONS REFER TO INSIDE DIMENSIONS.
5. 3 SIDES SEALING WITH 0.30 MINIMUM SEALING WIDTH
6. PRODUCT SPECIFIED HEREIN AND IT'S PACKING MATERIAL SUPPLIED TO BELFUSE MUST MEET EU RoHS REQUIREMENT.

REV. : G PAGE : 8

ORIGINATED BY
SANDY LIN
DATE 2017-03-10
DRAWN BY
XUE RIPING
DATE 2017-03-10

TITLE
SMD MagJack®
(4 Cores,MDIX,CM Termination)
S811-1X1T-06-F

PART NO. / DRAWING NO.
S8111X1T06-F
FILE NAME
S8111X1T06-F_G.DWG

STANDARD DIM. TOL. IN INCH		[] METRIC DIM. AS REF.
.X	±0.1	UNIT : INCH [mm]
.XX		SCALE : N/A
.XXX		SIZE : A4

