

FRONT VIEW

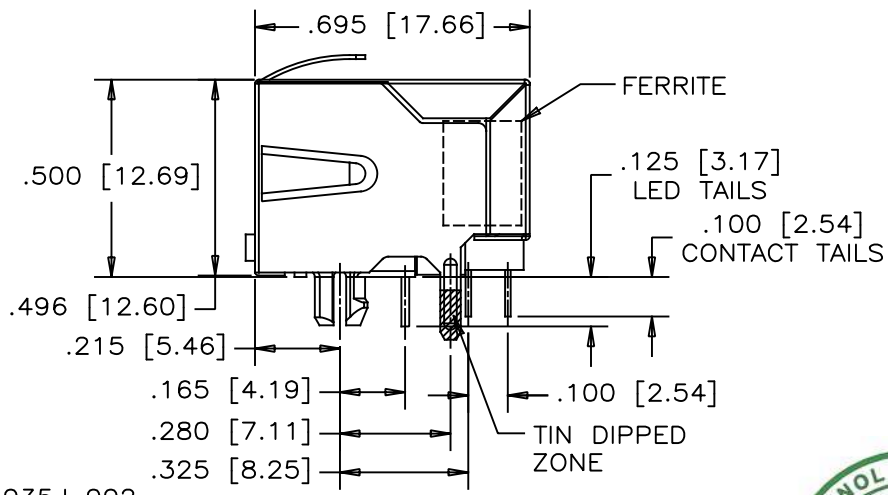

SIDE VIEW

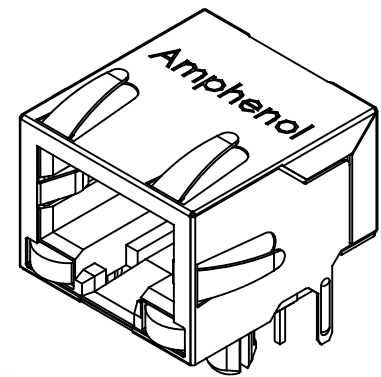

ISOMETRIC VIEW

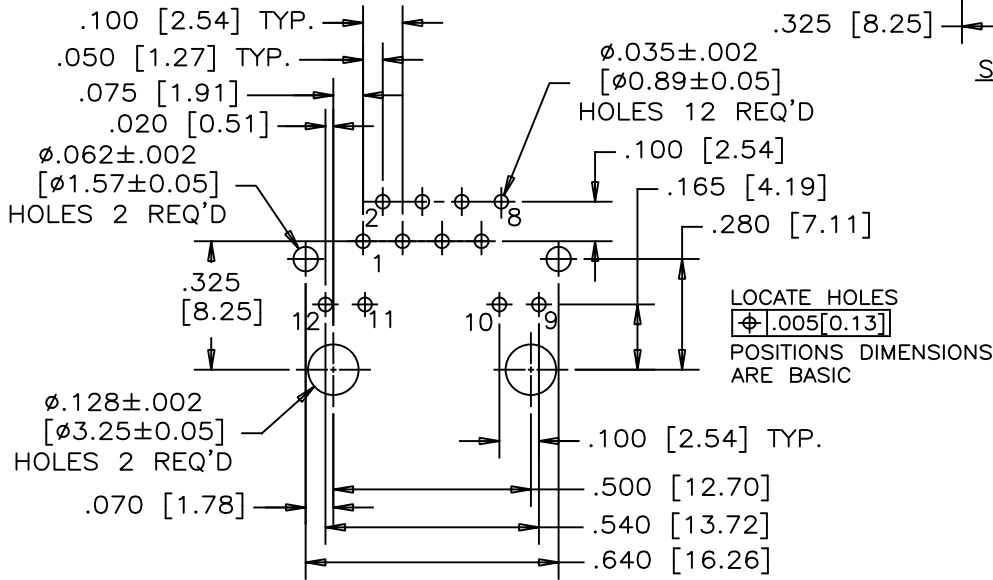

RECOMMENDED PCB LAYOUT
(COMPONENT SIDE OF BOARD)

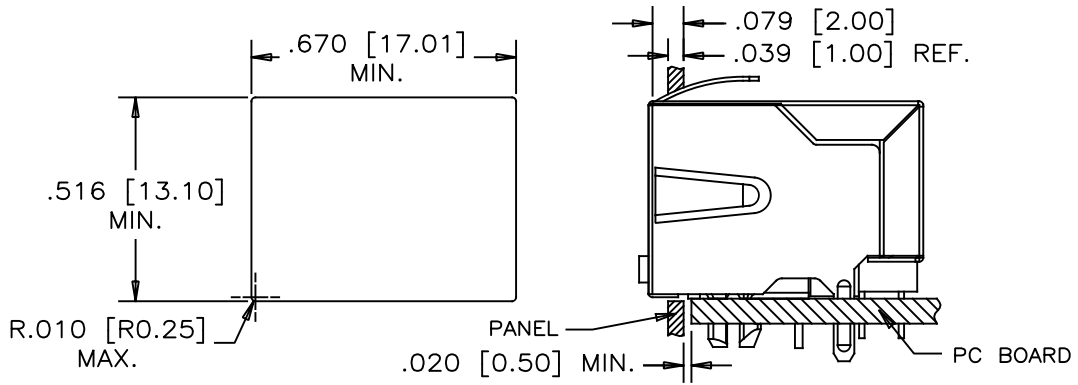

RECOMMENDED PANEL CUTOUT



MATERIALS:
HOUSING: ENGINEERING THERMOPLASTIC. FLAMMABILITY RATING UL 94V-0, COLOR: BLACK
CONTACTS: PHOSPHOR BRONZE
PLATING: SELECTIVE GOLD PLATING ON MATING SURFACE, SEE PART NO. FOR THICKNESS.
 50µ" [1.27 MICRONS] MIN. NICKEL UNDERPLATE.
 100µ" [2.54 MICRONS] MIN. MATTE-TIN OR GOLD FLASH ON CONTACT TAILS.
SHIELD: COPPER ALLOY
PLATING: NICKEL WITH TIN FINISHED ON PCB TAILS.

RECOMMENDED SOLDERING TEMPERATURE:
 WAVE SOLDERING AT 260° MAXIMUM FOR 5~8 SECONDS.

AMPHENOL PART NUMBER: RJSBE-X28X-C1X
GOLD PLATING OPTIONS:
 D= 6µ" GOLD PLATING
 G= 15µ" GOLD PLATING
 J= 30µ" GOLD PLATING
 5= 50µ" GOLD PLATING
 REFER TO LED OPTIONS DRAWING FOR ORDERING CODES, SEE PAGE 2

UNLESS SPECIFIED OTHERWISE		DRAWN	RONNIE.C	AUG14/20	Amphenol Canada Corp. Commercial Products
PRIMARY UNITS INCHES		CHECKED	KELVIN.T	AUG14/20	
SECONDARY MILLIMETERS		M.E. APP'D			SINGLE PORT MODULAR JACK, WITH FERRITE, 8 POSITION, 8 CONTACTS, SHIELDED GOLD PLATING OPTION, WITH LED OPTIONS -RoHS COMPLIANT
REFERENCE IN PARENTHESES		Q.A. APP'D			
GENERAL TOLERANCES		DWG APP'D			
1 DECIMAL PLACE		ENG. REL. NO.			
2 DECIMAL PLACES		REF.			DWG NO.
3 DECIMAL PLACES	±.015	THIRD ANGLE PROJECTION			P-RJSBE-X28X-C1X
ANGULAR DEGREES	±1.5°	DO NOT SCALE DRAWING			REV A
					CODE ID NO. 03554
					DWG SIZE X
					SCALE N/A
					SHEET 1 OF 2

REVISIONS			
REV	DESCRIPTION, ECN, EAR NO.	DATE	APP'D
A	PROPOSAL	AUG14/20	L.CHAN

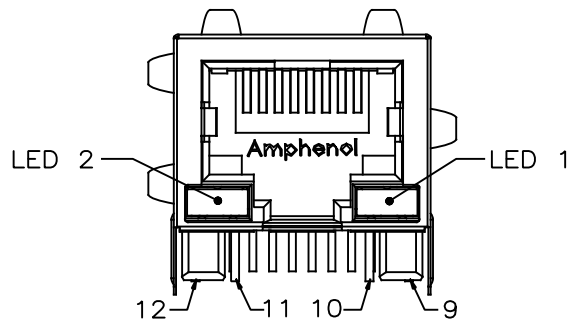

TYPICAL FOR SINGLE & MULTI-PORT

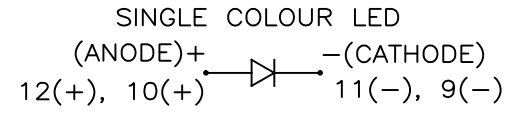
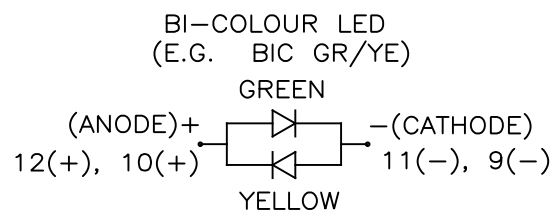

LED SCHEMATIC

LED SPECIFICATIONS:

FORWARD VOLTAGE:
 1.8~2.4 VOLTS.(FOR SINGLE COLORS)
 2.6~3.4 VOLTS.(FOR BI-COLORS)
 REVERSE VOLTAGE: 5.0 VOLTS MAX.
 LUMINOUS INTENSITY:
 6~60 mcd (FOR SINGLE COLORS) (AT If=20mA)
 3~15 mcd (FOR BI-COLORS) (AT If=20mA)
 OPERATING TEMPERATURE: -40°C TO 85° C
 WAVE SOLDERING TEMPERATURE: 260° C
 (5 SEC, 1/16" FROM CASE)
 PLATING ON TAILS: TIN OR TIN/COPPER ALLOY
 OVER SILVER

EXAMPLE:

PART NUMBER RJSBE-528X-C1

LED COLOR CODE

CODE	LED 2 (LEFT)	LED 1 (RIGHT)	CODE	LED 2 (LEFT)	LED 1 (RIGHT)	CODE	LED 2 (LEFT)	LED 1 (RIGHT)
0	BLOCKED	BLOCKED	9	GREEN	BLOCKED	J	BiC RD/GR	YELLOW
1	YELLOW	GREEN	A	BiC GR/YE	BiC GR/YE	K	YELLOW	BiC GR/OR
2	BLOCKED	GREEN	B	BiC RD/GR	BiC RD/GR	L	BiC GR/YE	RED
3	YELLOW	BLOCKED	C	BiC RD/GR	BiC GR/YE	M	RED	YELLOW
4	GREEN	YELLOW	D	GREEN	BiC GR/YE	N	BiC GR/RD	BiC GR/YE
5	GREEN	GREEN	E	YELLOW	BiC GR/YE	P	GREEN	BiC RD/GR
6	YELLOW	YELLOW	F	BiC GR/YE	YELLOW	R	BiC GR/OR	GREEN
7	RED	GREEN	G	BiC GR/OR	BiC GR/OR	T	RED	RED
8	GREEN	RED	H	BiC GR/YE	GREEN	V	BiC RD/GR	GREEN
			W	ADDITIONAL OPTIONS				

EXAMPLE OF ADDITIONAL LED OPTIONS:

PART NUMBER RJSBE-528W-C1X

ADDITIONAL LED COLOR CODE
 DENOTES ADDITIONAL LED OPTIONS TO BE USED

CODE	LED 2 (LEFT)	LED 1 (RIGHT)	CODE	LED 2 (LEFT)	LED 1 (RIGHT)	CODE	LED 2 (LEFT)	LED 1 (RIGHT)
0	DO NOT USE		5	BLOCKED	YELLOW	A	LOWC YE	LOWC YE
1	RED	BLOCKED	6	RED	BiC RD/GR	B	LOWC YE	LOWC GR
2	BiC GR/OR	YELLOW	7			C	LOWC GR	LOWC YE
3	YELLOW	RED	8	BiC RD/GR	BLOCKED	D	LOWC GR	LOWC GR
4	BLOCKED	RED	9	BiC GR/YE	BLOCKED	M	LOWC RD	LOWC YE
						N	GREEN	BiC GR/OR
						E	GREEN	ORANGE
						F	ORANGE	GREEN
						P	BiC RD/YE	GREEN
						R	BiC RD/YE	BiC RD/YE

PRIMARY COLOR FOR BI-COLOR

LEDS IN STANDARD ANODE/
 CATHODE CONFIGURATION IS:
 RED-GREEN= RED
 RED-YELLOW= RED
 GREEN-YELLOW= GREEN
 GREEN-ORANGE= GREEN

LEGEND

BiC=BI-COLOR LED
 LOWC=LOW CURRENT LED
 YE=YELLOW
 GR=GREEN
 RD=RED
 OR=ORANGE

NOTE:

THE TWO DIGITS PRECEDING THE
 ADDITIONAL LED CODE MUST BE
 USED IN THE PART NUMBER, WHEN
 ORDERING ANY OF THE ADDITIONAL
 LED OPTIONS.



UNLESS SPECIFIED OTHERWISE	DRAWN RONNIE.C	AUG14/20	Amphenol Canada Corp. Commercial Products
PRIMARY UNITS INCHES	CHECKED KELVIN.T	AUG14/20	
SECONDARY MILLIMETERS	M.E. APP'D		SINGLE PORT MODULAR JACK, WITH FERRITE, 8 POSITION, 8 CONTACTS, SHIELDED GOLD PLATING OPTION, WITH LED OPTIONS -RoHS COMPLIANT
REFERENCE IN PARENTHESES	Q.A. APP'D		
GENERAL TOLERANCES	DWG APP'D		
1 DECIMAL PLACE	ENG. REL. NO.		DWG NO.
2 DECIMAL PLACES	REF.		P-RJSBE-X28X-C1X
3 DECIMAL PLACES ±.015	THIRD ANGLE PROJECTION	DO NOT SCALE DRAWING	REV A
ANGULAR DEGREES ±1.5°			CODE ID NO. 03554 DWG SIZE X SCALE N/A SHEET 2 OF 2