



4.8DBTSW_D3 series

4.8W - Positive and Negative Dual Output - Wide Input - Isolated & Regulated regulated IGBT dedicated DC-DC converter

DC-DC Converter 4.8 Watt

- ⊕ Wide input voltage range
- ⊕ High efficiency up to 83%
- ⊕ Operating temperature range: -40°C to +105°C
- ⊕ Isolation voltage: 3K VDC
- ⊕ International standard pin-out
- ⊕ Components meet AEC-Q101 standards

The 4.8DBTSW_D3 series 4.8W output power, extremely wide range of voltage input of 7-18VDC, isolation voltage of 3000VDC. Production process in accordance with TS16949 system control, components meet AEC-Q101 standards, The product is special designed for automobile application.



Common specifications	
Short circuit protection	None
Operation temperature range	-40°C to +105°C (see Fig. 1)
Storage temperature range	-55°C to +125°C
Storage Humidity	5 -to 95 %RH (Non-condensing)
Lead temperature	300°C MAX, 1.5mm from case for 10 sec
Vibration	10-55Hz, 10G, 30 Min. along X, Y and Z
MTBF	>1,000,000 hours
Case material	Black flame-retardant and heat-resistant plastic [UL94-V0]
Cooling	Forced convection (the wind speed: 0.8m/s)
Weight	14g Typ.
Dimension	31.60*20.30*10.20mm

Output specifications						
Item	Test condition	Min	Typ	Max	Units	
Output Power		0.24		4.8	W	
Output voltage accuracy	• Main output, 5%-100% load (+15V output) • Supplement output, 5%-100% load(-9V output)		±5	±10	%	
Line regulation	Full load, the input voltage is from low voltage to high voltage		±5	±10	%	
Load regulation	5%-100% load		±5	±10	%	
Temperature coefficient	Full load			±0.03	% / °C	
Ripple & Noise**	Full load, 20MHz bandwidth		100	200	mV	
Switching frequency	Full load, nominal input		380		KHz	

* Ripple and noise are measured by "parallel cable" method, please see DC-DC Converter Application Notes for specific operation.

Input specifications					
Item	Test condition	Min	Typ	Max	Units
Input current	full load/ no-load 12VDC input		482/35	494/50	mA
Reflected Ripple Current	12VDC input		30		mA
Surge Voltage	60sec. max.	-0.7		30	VDC
Starting voltage			6.5	7	VDC
Input filter	Pi filter				
Hot plug	Unavailable				

Example:

4.8DBTSW_121509_D3P

4.8 = 4.8 Watt; D = DIP24; B = IGBT; TS = TS16949 certified;
12 = 12Vin; 15 = +15Vout; 09 = -9Vout; D = Dual Output;
3 = 3kVDC; P = Short Circuit Protection (SCP)

Isolation specifications					
Item	Test condition	Min	Typ	Max	Units
Isolation voltage	Input-Output, tested for 1 minute and leakage current less than 1mA	3000			VDC
Isolation resistance	Input-Output, test at 500VDC	1000			MΩ
Isolation capacitance	Input-output, 100KHz/0.1V		50		pF

EMC specifications

EMI	CE	EN55025 / CISPR25 CLASS 3 (see Fig.3-② and Fig.3-③ for recommended circuit)			
EMI	RE	EN55025 / CISPR25 CLASS 3 (see Fig.3-② and Fig.3-③ for recommended circuit)			
EMS	ESD	IEC/EN61000-4-2	Contact ±4KV	perf. Criteria B	
EMS	RS	IEC/EN61000-4-3	10V/m	perf. Criteria A	
EMS	EFT	IEC/EN61000-4-4	±2KV (see Fig.3-③ for recommended circuit)	perf. Criteria B	
EMS	Surge	IEC/EN61000-4-6	3 Vr.m.s	perf. Criteria A	
EMS	CS	IEC/EN61000-4-2	Contact ±4KV	perf. Criteria B	
EMS	Immunities of voltage dip, drop and short interruption	IEC/EN61000-4-29	0%, 70%	perf. Criteria B	

Product Selection Guide

Part Number	Input Voltage [Nominal, Range, V]	Output Voltage [VDC, +Vo/-Vo]	Output current [mA, +Vo/-Vo]	Max. capacitive Load ⁽²⁾ [μF]	Efficiency @ Full Load [% , Min/typ]
4.8DBTSW_121509_D3P	12 (7-18)	20	+15/-9	±200/±10	81/83

1. Absolute maximum rating without damage on the converter, but it isn't recommended;
2. For dual output converter, the given value is the same for each output.

4.8DBTSW_D3 series

4.8W - Positive and Negative Dual Output - Wide Input - Isolated & Regulated regulated IGBT dedicated DC-DC converter

Typical characteristics

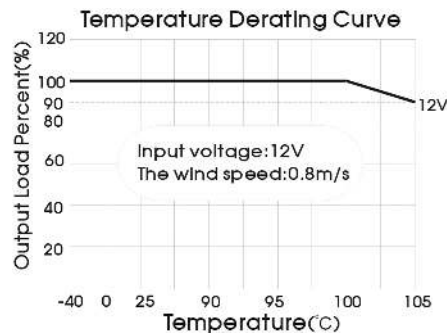
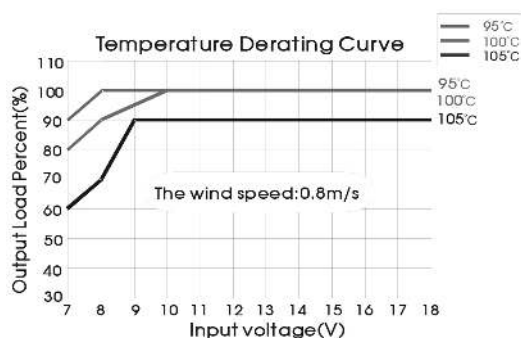
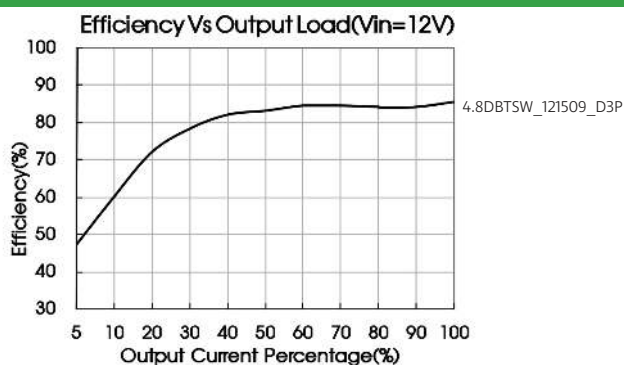
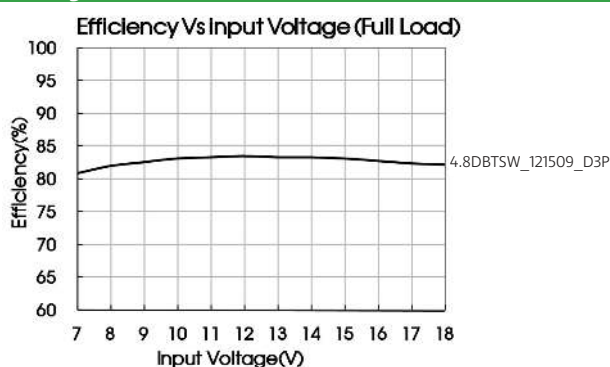

Fig. 1

Efficiency



Typical application

All the IGBT driver of this series are tested according to the recommended circuit (see Fig. 2) before delivery.

If it is required to further reduce input and output ripple, properly increase the input & output of additional capacitors C_{in} and C_{out} or select capacitors of low equivalent impedance provided that the capacitance is no larger than the max. capacitive load of the product.

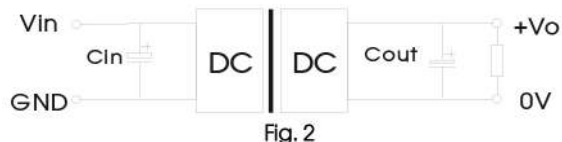

Vin	12V
Cin	100 μ F
Cout	100 μ F

EMC solution-recommended

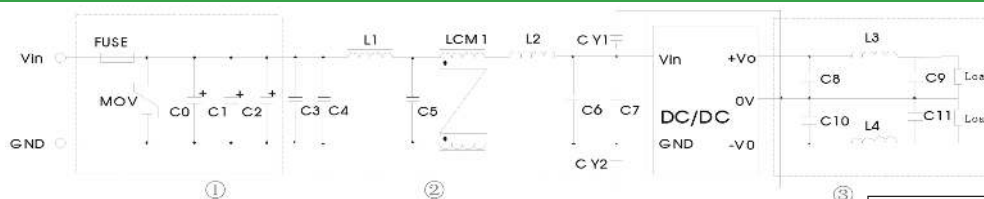

Note: Part ① in the Fig. 3 is used for EMS test ; part ② and part ③ are used for EMI filtering; selected based on needs.

Model	4.8DBTSW_121509_D3P
FUSE	Choose according to actual input current
MOV	S14K20
C0,C1,C2	330 μ F/50V
C3	4.7 μ F/50V
C4	10 μ F/50V
L1	4.7 μ H
C5	0.1 μ F/50V
LCM1	10mH
L2,L3,L4	1700 Ω /60MHz
C6,C8,C9,C10,C11	0.1nF/50V
C7	1nF/50V
CY1,CY2	561K/400VAC

4.8DBTSW_D3 series

4.8W - Positive and Negative Dual Output - Wide Input - Isolated & Regulated regulated IGBT dedicated DC-DC converter

Application circuit

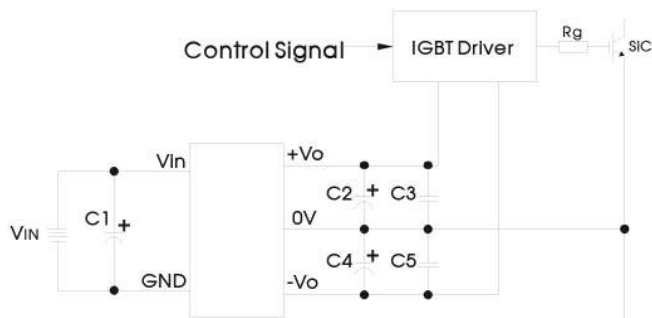

C1: 100 μ F/63V (Electrolytic capacitor)
 C2,C4: 100 μ F/35V (Electrolytic capacitor)
 C3,C5: 10 μ F/25V (Ceramic capacitor)

Application Notes

1. The wire between the converter and IGBT driver must as short as possible.
2. External filter capacitors should be connected as close as possible to the IGBT driver.
3. To ensure the high peak gate current, the filter capacitors should be electrolytic capacitor and ceramic capacitor collocation.
4. The output average power of the IGBT driver should be less than the output power of DC-DC module.

Mechanical dimensions

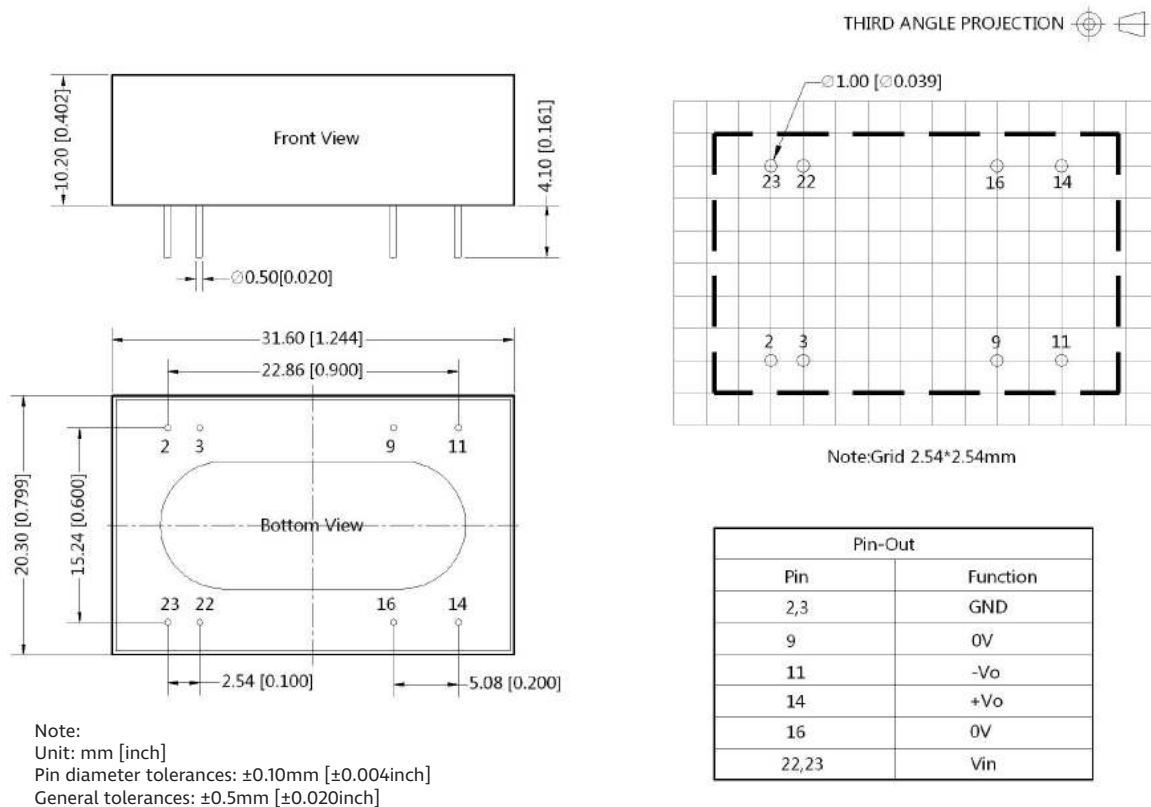

Note:

1. Recommend to use module with more than 5% load, if not, the ripple of the product may exceeds the specification, but does not affect the reliability of the product;
2. The recommended unbalance degree of the dual output module load is $\leq \pm 5\%$; if the degree exceeds $\pm 5\%$, than the product performance cannot be guaranteed to comply with all parameters in the datasheet. Please contact our technicians directly for specific information;
3. The maximum capacitive load offered were tested at input voltage range and full load;
4. Unless otherwise specified, parameters in this datasheet were measured under the conditions of $T_a=25^\circ\text{C}$, humidity < 75%RH with nominal input voltage and rated output load;
5. All index testing methods in this datasheet are based on Company's corporate standards;
6. We can provide product customization service, please contact our technicians directly for specific information;
7. Specifications are subject to change without prior notice.
8. It is not allowed to connect modules output in parallel to enlarge the power