

This product represents our selection of standard resistance weld type quartz crystals.

- OPTIONS:
- extended temperature range
  - pullability
  - mylar spacer
  - vinyl sleeve
  - third ground lead
  - radial Tape and Reel (1,000 pcs)

## FEATURES

- Cost effective
- Excellent aging
- Wide frequency range
- Tight tolerances
- Excellent reliability
- "AT" cut crystal

## PART NUMBERING GUIDE "EXAMPLE"

	FREQUENCY (16.0000 MHz)	LOAD CAPACITANCE*	PACKAGE TYPE
ECS	160	20	1

\* Load capacitance (xx=xx pF, S= series resonance)  
 Note: See Product Selection Guide for additional options.

## OPERATING CONDITIONS/ELECTRICAL CHARACTERISTICS

PARAMETERS	CONDITIONS	MINIMUM	MAXIMUM	UNITS
FREQUENCY RANGE	$f_0$	1.800	100.000	MHz
FREQUENCY TOLERANCE	Ref @ +25°C	-30	+30	PPM
FREQUENCY STABILITY	Ta=-10°C ~ +70°C	-50	+50	PPM
OPERATING TEMPERATURE	T <sub>OPR</sub>	-10	+70	°C
STORAGE TEMPERATURE	T <sub>STG</sub>	-30	+85	°C
SHUNT CAPACITANCE	C <sub>0</sub>		7.0	pF
LOAD CAPACITANCE	C <sub>L</sub> (Customer Specified)	10.0	Series	pF
DRIVE LEVEL	1.800 ~ 3.000MHz, 3.000 ~ 100.000MHz		2.0, 1.0	mW
AGING (FIRST YEAR)	@ +25°C	-5.0	+5.0	PPM

## EQUIVALENT SERIES RESISTANCE / MODE OF OSCILLATION

FREQUENCY RANGE (MHz)	MODE	MAX ESR Ω	FREQUENCY RANGE (MHz)	MODE	MAX ESR Ω
1.800 ~ 1.999	Fundamental	750	5.000 ~ 5.999	Fundamental	50
2.000 ~ 2.399	Fundamental	500	6.000 ~ 7.999	Fundamental	40
2.400 ~ 2.999	Fundamental	300	8.000 ~ 9.999	Fundamental	35
3.000 ~ 3.199	Fundamental	200	10.000 ~ 12.499	Fundamental	30
3.200 ~ 3.699	Fundamental	120	12.500 ~ 15.999	Fundamental	25
3.700 ~ 4.199	Fundamental	100	16.000 ~ 25.000	Fundamental	20
4.200 ~ 4.899	Fundamental	70	23.000 ~ 100.000	3rd O/T	40
4.900 ~ 4.999	Fundamental	55			

## PACKAGE DIMENSIONS (mm)

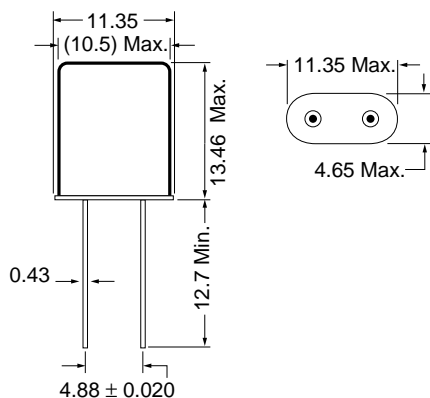

Figure 1) HC-49U - Side and Bottom views

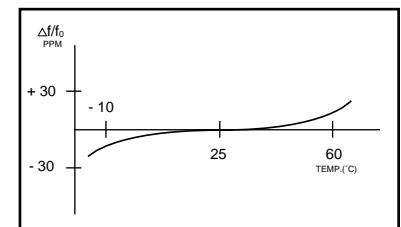

Figure 2) Frequency vs Temperature Curve