

# NHD-C0216CZ-NSW-BBW-3V3

## COG (Chip-on-Glass) Liquid Crystal Display Module

NHD- Newhaven Display  
C0216- COG, 2 Lines x 16 Characters  
CZ- Model  
N- Transmissive  
SW- Side White LED Backlight  
B- STN-Blue Negative  
B- 6:00 Optimal View  
W- Wide Temperature  
3V3- 3V LCD, 3V Backlight  
**RoHS Compliant**

**Newhaven Display International, Inc.**

2661 Galvin Ct.

Elgin IL, 60124

Ph: 847-844-8795

Fax: 847-844-8796

[www.newhavendisplay.com](http://www.newhavendisplay.com)

[nhtech@newhavendisplay.com](mailto:nhtech@newhavendisplay.com)

[nhsales@newhavendisplay.com](mailto:nhsales@newhavendisplay.com)

## Document Revision History

Revision	Date	Description	Changed by
0	11/11/2008	Initial Release	
1	8/26/2009	User guide reformat	BE
2	10/9/2009	Updated Electrical Characteristics	MC
3	10/27/2009	Updated block diagram	MC
4	11/19/2009	Updated backlight supply current	MC
5	12/18/2009	Pin description updated	BE
6	2/17/2011	Font table updated	AK
7	7/19/2011	Viewing angles updated	AK
8	3/2/2012	Interface information updated	AK
9	7/22/2013	Electrical characteristics updated	ML
10	12/10/2014	Recommended connector information updated	AK
11	10/20/16	Mechanical Drawing, Electrical & Optical Char. Updated	SB
12	1/20/17	P/N Printed on Back of Display, Electrical Char. Updated	SB
13	8/24/18	Supply Current Updated	SB
14	11/15/18	Updated Font table for CGRAM	TM
15	6/24/19	Added PCB Footprint Drawing	AS
16	9/12/19	Supply Current Updated	SB

## Functions and Features

- 2 lines x 16 characters
- Built-in controller (ST7032)
- 5x8 dots with cursor
- 4-line serial interface
- 1/16 duty, 1/5 bias

SYMBOL	REVISION	DATE

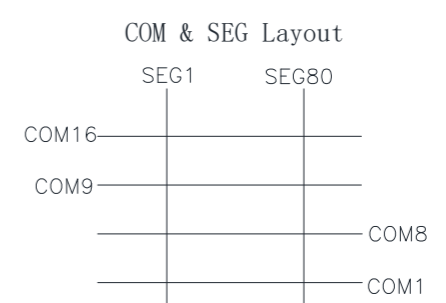
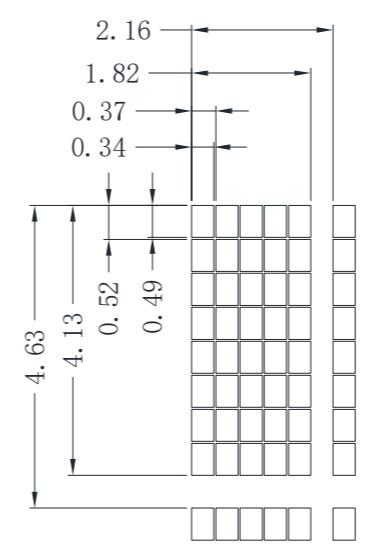
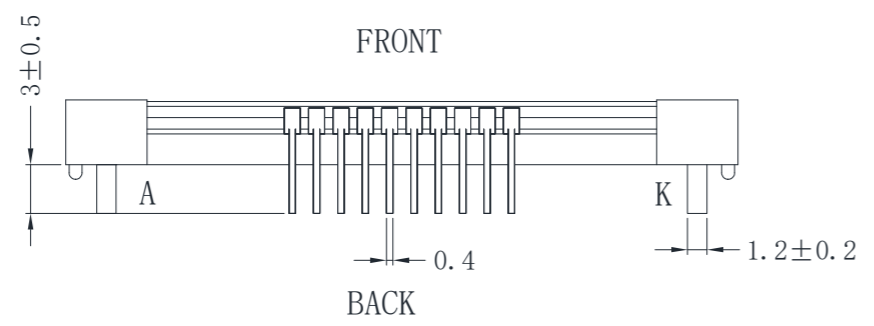
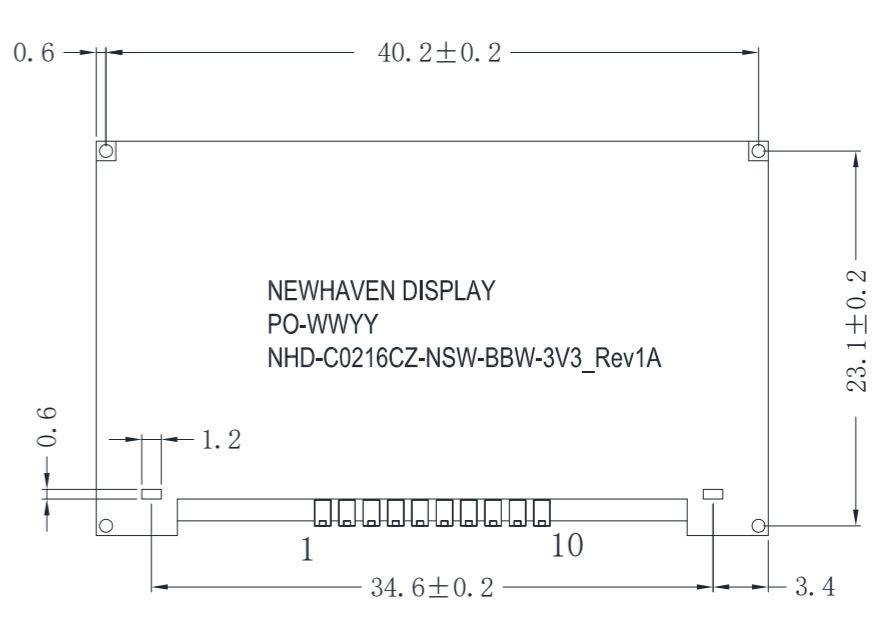
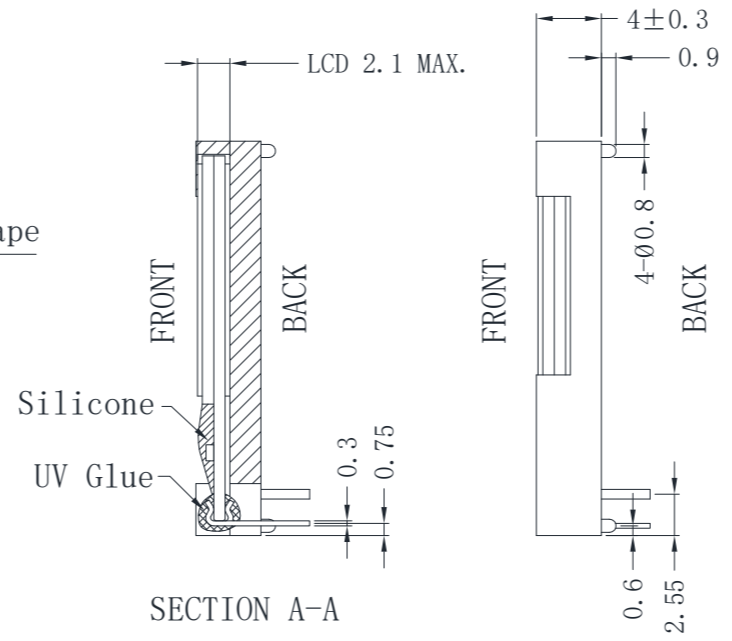
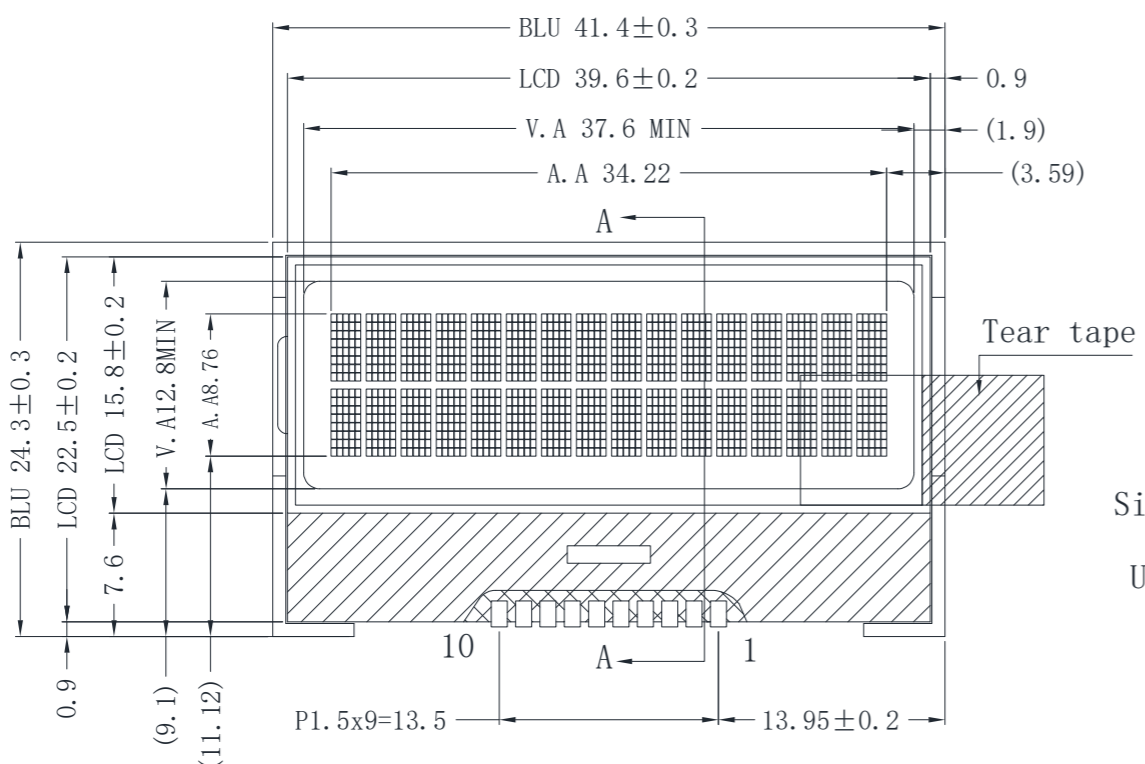

Pin assignment	
NO.	Symbol
1	RST
2	RS
3	CSB
4	SCL
5	SI
6	VSS
7	VDD
8	VOUT
9	C1+
10	C1-

- Notes:**
- 1. Driver: 1/16 Duty, 1/5 Bias
  - 2. Voltage: 3.3V VDD, 5.5V VLCD
  - 3. Display Mode: STN Negative / Blue / Transmissive
  - 4. Optimal View: 6:00
  - 5. Backlight: White LED
  - 6. Driver IC: ST7032

STANDARD TOLERANCE: (UNLESS OTHERWISE SPECIFIED)

LINEAR: ±0.3mm

UNLESS OTHERWISE SPECIFIED: - DIMENSIONS ARE IN MILLIMETERS - THIRD ANGLE PROJECTION

DO NOT SCALE DRAWING

THIS DRAWING IS SOLELY THE PROPERTY OF NEWHAVEN DISPLAY INTERNATIONAL, INC. THE INFORMATION IT CONTAINS IS NOT TO BE DISCLOSED, REPRODUCED OR COPIED IN WHOLE OR PART WITHOUT WRITTEN APPROVAL FROM NEWHAVEN DISPLAY.

**NEWHAVEN DISPLAY INTERNATIONAL**

DRAWING/PART NUMBER: NHD-C0216CZ-NSW-BBW-3V3

REVISION: 1A

SIZE: A3

SCALE: NS

SHEET 1 OF 1

DRAWN BY: S. Baxi

APPROVED BY: S. Baxi

DRAWN DATE: 9/12/19



APPROVED DATE: 9/12/19

# Recommended PCB Footprint

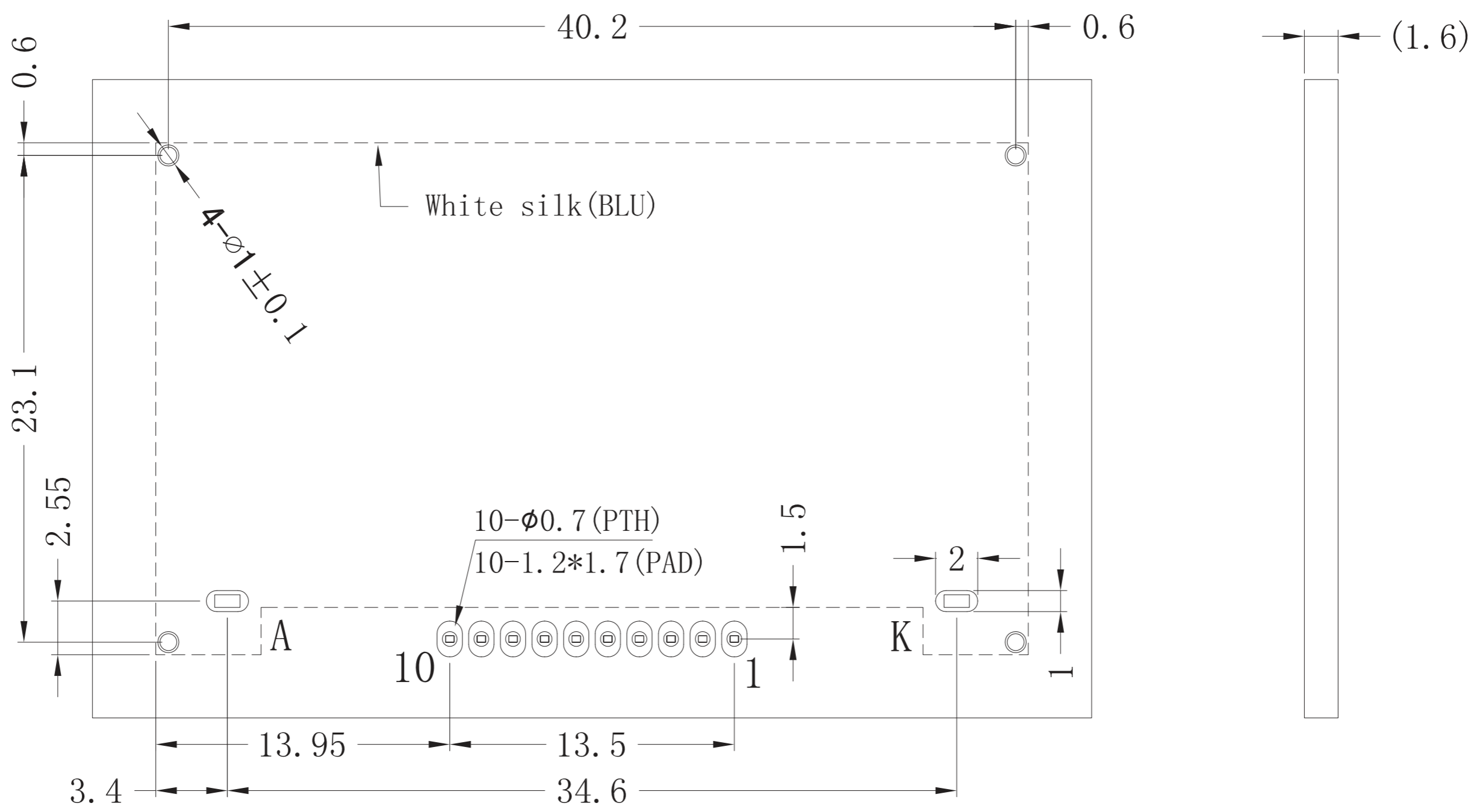
SYMBOL	REVISION	DATE



**Applicable Displays:**  
 1) NHD-C0216CZ-NSW-BBW-3V3  
 2) NHD-C0216CZ-FSW-FBW-3V3

STANDARD TOLERANCE: (UNLESS OTHERWISE SPECIFIED)		
	LINEAR: $\pm 0.3\text{mm}$	REVISION: 1.0
UNLESS OTHERWISE SPECIFIED: - DIMENSIONS ARE IN MILLIMETERS - THIRD ANGLE PROJECTION 	DRAWING/PART NUMBER: NHD-C0216CZ-Footprint	SIZE: A3
	DRAWN BY: A. Shah	APPROVED BY: A. Khan
	DRAWN DATE: 6/4/19	APPROVED DATE: 6/4/19
	SCALE: NS	SHEET 1 OF 1
DO NOT SCALE DRAWING		
THIS DRAWING IS SOLELY THE PROPERTY OF NEWHAVEN DISPLAY INTERNATIONAL, INC. THE INFORMATION IT CONTAINS IS NOT TO BE DISCLOSED, REPRODUCED OR COPIED IN WHOLE OR PART WITHOUT WRITTEN APPROVAL FROM NEWHAVEN DISPLAY.		

## Pin Description and Wiring Diagram

Pin No.	Symbol	External Connection	Function Description
1	RST	MPU	Active LOW Reset Signal
2	RS	MPU	Register Select signal. RS=0: instruction; RS=1: data
3	CSB	MPU	Active LOW Chip Select signal
4	SCL	MPU	Serial Clock
5	SI	MPU	Serial Input data
6	V <sub>SS</sub>	Power Supply	Ground
7	V <sub>DD</sub>		Power supply for logic for LCD (3.0V).
8	V <sub>OUT</sub>		DC/DC voltage converter. 1uF capacitor to V <sub>DD</sub> or V <sub>SS</sub>
9	C1+		Voltage booster circuit. Connect to 0.47uF-2.2uF cap to PIN10.
10	C1-		Voltage booster circuit. Connect to 0.47uF-2.2uF cap to PIN9.
A	LED+	Power Supply	Backlight Anode (3.0V)
K	LED-	Power Supply	Backlight Cathode (Ground)

**Recommended LCD connector:** LCD pins should be soldered directly onto thru-hole connection on PCB

**Backlight connector:** Backlight pins should be soldered directly onto thru-hole connection on PCB

**Recommended Breakout Board:** [NHD-PCB0216CZ](#)

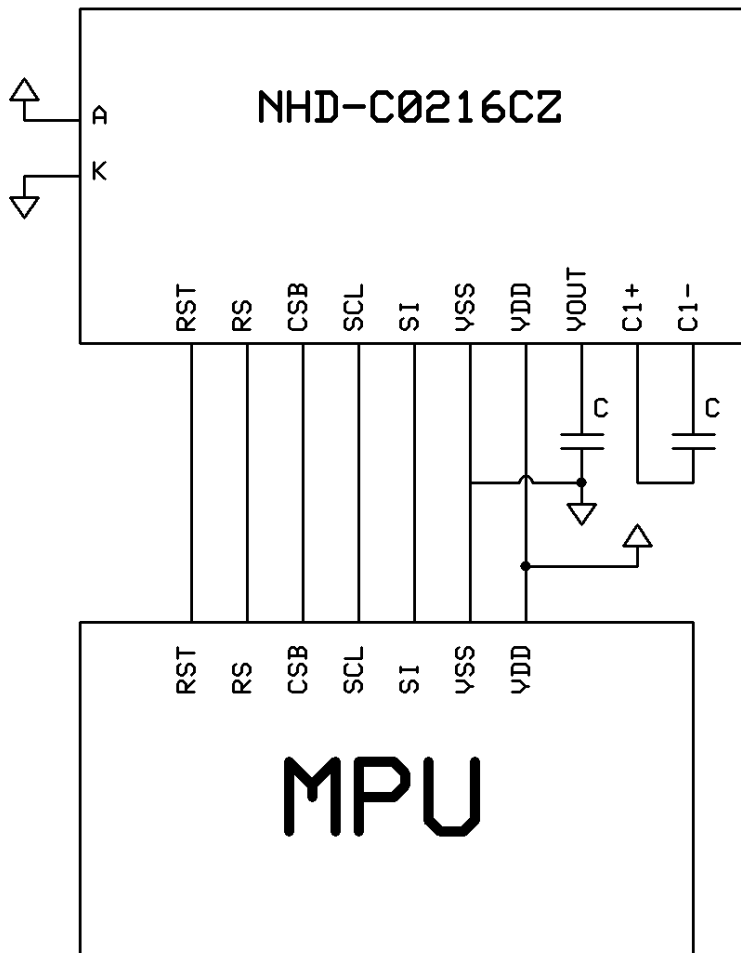

## Electrical Characteristics

Item	Symbol	Condition	Min.	Typ.	Max.	Unit
Operating Temperature Range	T <sub>OP</sub>	Absolute Max	-20	-	+70	°C
Storage Temperature Range	T <sub>ST</sub>	Absolute Max	-30	-	+80	°C
Supply Voltage	V <sub>DD</sub>	-	3.0	3.3	3.6	V
Supply Current	I <sub>DD</sub>	V <sub>DD</sub> = 3.3V	40	170	300	μA
Supply for LCD (contrast)	V <sub>LCD</sub>	T <sub>OP</sub> = 25°C	5.2	5.5	5.8	V
"H" Level input	V <sub>IH</sub>	-	1.9	-	V <sub>DD</sub>	V
"L" Level input	V <sub>IL</sub>	-	V <sub>SS</sub>	-	0.8	V
"H" Level output	V <sub>OH</sub>	-	0.75*V <sub>DD</sub>	-	V <sub>DD</sub>	V
"L" Level output	V <sub>OL</sub>	-	V <sub>SS</sub>	-	0.8	V
Backlight Supply Voltage	V <sub>LED</sub>	-	3.0	3.1	3.2	V
Backlight Supply Current	I <sub>LED</sub>	V <sub>LED</sub> = 3.1V	10	30	36	mA

## Optical Characteristics

Item	Symbol	Condition	Min.	Typ.	Max.	Unit
Optimal Viewing Angles	Top	CR ≥ 2	-	20	-	°
	Bottom		-	40	-	°
	Left		-	40	-	°
	Right		-	40	-	°
Contrast Ratio	CR	-	2	6	-	-
Response Time	Rise	T <sub>OP</sub> = 25°C	150	200	300	ms
	Fall		200	250	350	ms

## Controller Information

Built-in ST7032 controller.

Please download specification at [http://www.newhavendisplay.com/app\\_notes/ST7032.pdf](http://www.newhavendisplay.com/app_notes/ST7032.pdf)

## DDRAM Address

1	2	3	4	5	6	7	8	9	10	11	12	13	14	15	16
00	01	02	03	04	05	06	07	08	09	0A	0B	0C	0D	0E	0F
40	41	42	43	44	45	46	47	48	49	4A	4B	4C	4D	4E	4F

# Table of Commands

Instruction	Instruction code										Description	Instruction Execution Time			
	RS	R/W	DB7	DB6	DB5	DB4	DB3	DB2	DB1	DB0		OSC=380kHz	OSC=540kHz	OSC=700kHz	
Clear Display	0	0	0	0	0	0	0	0	0	0	1	Write "20H" to DDRAM and set DDRAM address to "00H" from AC	1.08 ms	0.76 ms	0.59 ms
Return Home	0	0	0	0	0	0	0	0	0	1	X	Set DDRAM Address to "00H" from AC and return cursor to its original position if shifted. The contents of DDRAM are not changed.	1.08 ms	0.76 ms	0.59 ms
Entry Mode Set	0	0	0	0	0	0	0	0	1	I/D	S	Sets cursor move direction and specifies display shift. These parameters are performed during data write and read.	26.3 μs	18.5 μs	14.3 μs
Display ON/OFF	0	0	0	0	0	0	0	1	D	C	B	D=1: Entire display on C=1: Cursor on B=1: Blinking cursor on	26.3 μs	18.5 μs	14.3 μs
Function set	0	0	0	0	1	DL	N	DH	IS2	IS1		DL: Interface data is 8/4 bits N: Number of lines is 2/1 DH: Double Height Font IS 2-1: Instruction Table Select	26.3 μs	18.5 μs	14.3 μs
Set DDRAM Address	0	0	1	AC6	AC5	AC4	AC3	AC2	AC1	AC0		Set DDRAM address in address counter.	26.3 μs	18.5 μs	14.3 μs
Read busy Flag and Address	0	1	BF	AC6	AC5	AC4	AC3	AC2	AC1	AC0		Whether during internal operation or not can be known by reading BF. The contents of address counter can also be read.	0	0	0
Write data To Address	1	0	D7	D6	D5	D4	D3	D2	D1	D0		Write data into internal RAM (DDRAM/CGRAM).	26.3 μs	18.5 μs	14.3 μs
Read data From RAM	1	1	D7	D6	D5	D4	D3	D2	D1	D0		Read data from internal RAM (DDRAM/CGRAM/ICONRAM).	26.3 μs	18.5 μs	14.3 μs

Instruction Table 0 (IS[2:1] = [0,0])															
Cursor or Display shift	0	0	0	0	0	1	S/C	R/L	X	X		Sets cursor moving and display shift control bit, and the direction without changing DDRAM data.	26.3 μs	18.5 μs	14.3 μs
Set CGRAM	0	0	0	1	AC5	AC4	AC3	AC2	AC1	AC0		Set CGRAM address in address counter	26.3 μs	18.5 μs	14.3 μs

Instruction Table 1 (IS[2:1] = [0,1])															
Internal OSC Frequency	0	0	0	0	0	1	BS	F2	F1	F0		BS = 1 : 1/4 bias BS = 0 : 1/5 bias F2~0 : Adjust internal OSC frequency for FR frequency	26.3 μs	18.5 μs	14.3 μs
Set ICON Address	0	0	0	1	0	0	AC3	AC2	AC1	AC0		Set ICON address in address counter	26.3 μs	18.5 μs	14.3 μs
Power/ICON control/Contrast set	0	0	0	1	0	1	Ion	Bon	C5	C4		Ion: ICON display on/off Bon: Set booster circuit on/off C5,C4: Contrast set for internal follower mode	26.3 μs	18.5 μs	14.3 μs
Follower Control	0	0	0	1	1	0	Fon	Rab <sub>2</sub>	Rab <sub>1</sub>	Rab <sub>0</sub>		Fon: Set follower circuit on/off Rab 2~0: select follower amplified ratio	26.3 μs	18.5 μs	14.3 μs
Contrast Set	0	0	0	1	1	1	C3	C2	C1	C0		Contrast set for internal follower mode.	26.3 μs	18.5 μs	14.3 μs

Instruction Table 2 (IS[2:1] = [1,0])															
Double Height Position Select	0	0	0	0	0	1	UD	X	X	X		UD: Double height position Select	26.3 μs	18.5 μs	14.3 μs
Reserved	0	0	0	1	X	X	X	X	X	X		Do not use (Reserved for Test)	26.3 μs	18.5 μs	14.3 μs

\*Instruction Table 3 (IS[2,1] = [1,1]): Do not use (Reserved for Test)

## Timing Characteristics

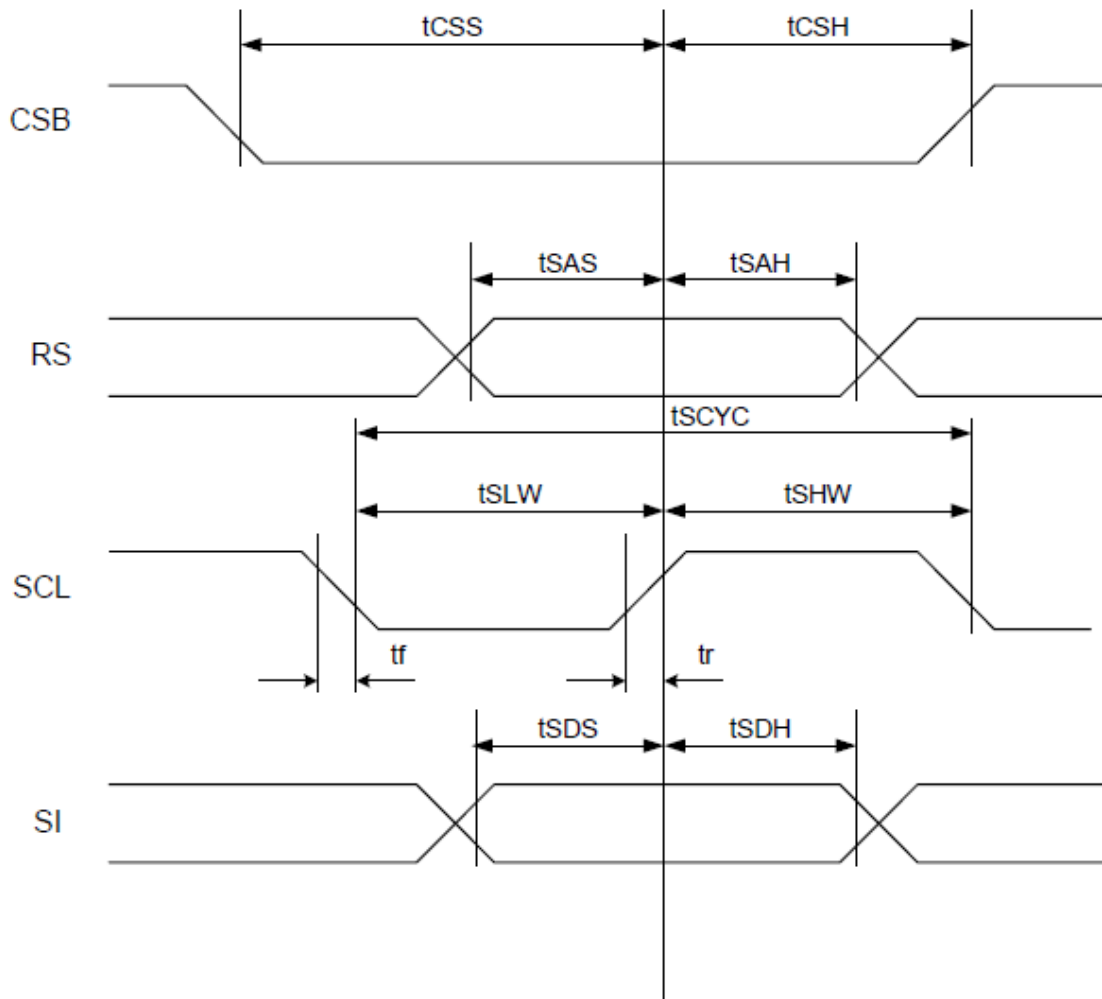

( $T_a = 25^\circ\text{C}$ )

Item	Signal	Symbol	Condition	VDD=2.7 to 4.5V Rating		VDD=4.5 to 5.5V Rating		Units
				Min.	Max.	Min.	Max.	
Serial Clock Period	SCL	$t_{SCYC}$	—	200	-	100	-	ns
SCL "H" pulse width		$t_{SHW}$		20	-	20	-	
SCL "L" pulse width		$t_{SLW}$		160	-	120	-	
SCL Rise/Fall time	SCL	$t_r, t_f$	—	-	20	-	20	ns
Address setup time	RS	$t_{SAS}$	—	10	-	10	-	ns
Address hold time		$t_{SAH}$		250	-	150	-	
Data setup time	SI	$t_{SDS}$	—	10	-	10	-	ns
Data hold time		$t_{SDH}$		10	-	20	-	
CS-SCL time	CS	$t_{CSS}$	—	20	-	20	-	ns
		$t_{CSH}$		350	-	200	-	



# Built-In Font Table

ST7032-0D (ITO option OPR1=0, OPR2=0)

b7-b4 b3-b0	0000	0001	0010	0011	0100	0101	0110	0111	1000	1001	1010	1011	1100	1101	1110	1111	
0000	Replaced By CGRAM Pattern	Q	R	S	T	U	V	W	X	Y	Z	[	]	^	_	~	
0001		+	,	.	/	:	;	<	=	>	?	@	A	B	C	D	
0010		E	F	G	H	I	J	K	L	M	N	O	P	Q	R	S	T
0011		U	V	W	X	Y	Z	[	]	^	_	~					
0100																	
0101																	
0110																	
0111																	
1000	Replaced By CGRAM Pattern																
1001																	
1010																	
1011																	
1100																	
1101																	
1110																	
1111																	

## Example Initialization Program

```
void init()
//initialize the LCD
{
  P3 = 1;
  P1 = 1;
  RST = 0;           //RESET
  delay(2);
  RST = 1;           //end reset
  delay(20);
  Writecom(0x30);    //wake up
  delay(2);
  Call writecom(0x30); //wake up
  Call writecom(0x30); //wake up
  Call writecom(0x39); //function set
  Call writecom(0x14); //internal osc frequency
  Call writecom(0x56); //power control
  Call writecom(0x6D); //follower control
  Call writecom(0x70); //contrast
  Call writecom(0x0C); //display on
  Call writecom(0x06); //entry mode
  Call writecom(0x01); //clear
  delay(10);
}

void writecom(int d)
{
  CS = 0;           //CS
  RS = 0;           //A0 = Command
  for(serialcounter = 1; serialcounter <= 8; serialcounter++) //send 8 bits
  {
    if((d&0x80)==0x80) //get only the MSB
      SI=1;           //if 1, then SI=1
    else
      SI=0;           //if 0, then SI=0
    d=(d<<1);        //shift data byte left
    SCL = 0;
    SCL = 1;
    SCL = 0;         //SCL
  }
  CS = 1;
}

void writedata(int d)
{
  CS = 0;           //CS
  RS = 1;           //A0 = Data
  for(serialcounter = 1; serialcounter <= 8; serialcounter++) //send 8 bits
  {
    if((d&0x80)==0x80) //get only the MSB
      SI=1;           //if 1, then SI=1
    else
      SI=0;           //if 0, then SI=0
    d=(d<<1);        //shift data byte left
    SCL = 0;
    SCL = 1;
    SCL = 0;         //SCL
  }
  CS = 1;
}
```

## Quality Information

Test Item	Content of Test	Test Condition	Note
High Temperature storage	Endurance test applying the high storage temperature for a long time.	+80°C , 96hrs	2
Low Temperature storage	Endurance test applying the low storage temperature for a long time.	-30°C , 96hrs	1,2
High Temperature Operation	Endurance test applying the electric stress (voltage & current) and the high thermal stress for a long time.	+70°C , 96hrs	2
Low Temperature Operation	Endurance test applying the electric stress (voltage & current) and the low thermal stress for a long time.	-20°C , 96hrs	1,2
High Temperature / Humidity Operation	Endurance test applying the electric stress (voltage & current) and the high thermal with high humidity stress for a long time.	+40°C , 90% RH , 96hrs	1,2
Thermal Shock resistance	Endurance test applying the electric stress (voltage & current) during a cycle of low and high thermal stress.	-20°C, 60min -> 25°C, 5min -> 70°C, 60min = 1 cycle For 20 cycles	
Vibration test	Endurance test applying vibration to simulate transportation and use.	10-55Hz, 5G Acceleration. 60 sec in each of 3 directions X,Y,Z for 30 minutes	3
Static electricity test	Endurance test applying electric static discharge.	VS=8kV, RS=330Ω, CS=150pF five times	

**Note 1:** No condensation to be observed.

**Note 2:** Conducted after 4 hours of storage at 25°C, 0%RH.

**Note 3:** Test performed on product itself, not inside a container.

## Precautions for using LCDs/LCMs

See Precautions at [www.newhavendisplay.com/specs/precautions.pdf](http://www.newhavendisplay.com/specs/precautions.pdf)

## Warranty Information and Terms & Conditions

[http://www.newhavendisplay.com/index.php?main\\_page=terms](http://www.newhavendisplay.com/index.php?main_page=terms)