

ITEM	MOLEX P/N	COLOR	MATING CONNECTOR	
			P/N	DRAWING
1	31414-8600	BLACK	31404-8XXX	SD-31404-81

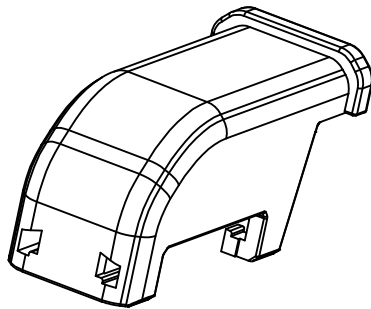
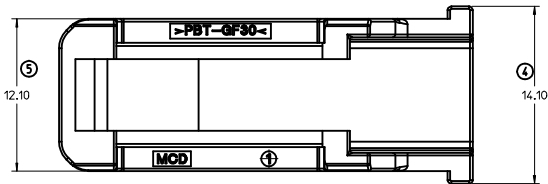
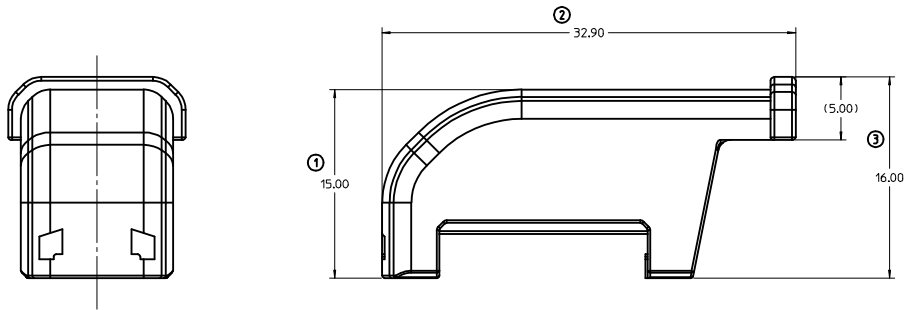

NOTES: VALID UNLESS OTHERWISE SPECIFIED

1. GENERAL:
    - a. APPLICATION SPECIFICATION SEE: AS-31402-000
    - COMPONENTS ARE OPTIONAL AND MUST BE PURCHASED SEPERATELY
  2. PRODUCT SPECIFICATION
    - GMW3191, JUNE 2012 SEQ #286 CONNECTOR MOUNTING FEATURE MECHANICAL STRENGTH.
    - DIRECTION F1 TO F5 SHALL BE > 50 N
    - DIRECTION F6 SHALL BE > 110N
  3. PACKAGING SPECIFICATION SEE PK-31300-256
  - d. PARTS MUST BE IN COMPLIANCE TO MOLEX CHEMICAL SUBSTANCES FOR PRODUCTS AND PACKAGING SPECIFICATION: OEHS-699000-300
  - e. DATA MUST BE SUBMITTED UNDER THE MOLEX PART NUMBER TO IMDS (COMPANY ID#13255)
2. DESIGN - MATERIALS: PBT 30% GLASS FILLED
3. DESIGN GEOMETRY:
    - a. THIS IS A 100% CAD GENERATED PART. THE CAD MATHEMATICAL DATA IS THE MASTER FOR THIS PART. FOR DIMENSIONAL OR ANY INFORMATION NOT SHOWN ON THIS DRAWING, ANALYZE THE CAD MODEL.
    - b. DIMENSION TOLERANCES PER#0.3
    - c. VISUAL DEFECTS SHALL MEET COSMETIC STANDARD PS-45499-002 (CLASS B).
    - d. DRAFT OF 2° PRESENT.
    - e. ALLOWABLE FLASH, PARTING LINES MISMATCH, EJECTOR PINS MARK, AND GATE VESTIGE TO BE +0.30 MAX PROTUSION.

INSPECTION BALLOON NUMBER LOG											
PER DRAWING REVISION: INITIAL											
LAST BALLOON NUMBER USED: 5											
ADDED BALLOON NUMBERS:											
REMOVED BALLOON NUMBERS:											
A RELEASE FOR SALSA SAP # 10668642											
INITIAL RELEASE EC NO: UA02015-0933 DRAWING I/O: CHKD: JDENG02 APPROD: LISLE 2014/11/14 2014/11/14 2015/01/16		QUALITY SYMBOLS ∇=0 ∇=0 ∇=0		GENERAL TOLERANCES (UNLESS SPECIFIED) mm INCH 4 PLACES ± --- ± --- 3 PLACES ± --- ± --- 2 PLACES ± --- ± --- 1 PLACE ± --- ± --- 0 PLACE ± --- ± --- ANGULAR ± 1° DRAFT WHERE APPLICABLE MUST REMAIN WITHIN DIMENSIONS		DIMENSION STYLE MM ONLY DRAWN BY DATE GL104 2014/11/11 CHECKED BY DATE JDENG02 2014/11/14 APPROVED BY DATE DC_LISLE 2015/01/16		SCALE 5:1 DESIGN UNITS METRIC THIRD ANGLE PROJECTION		TITLE 0.64MM 8 WAY WIRE DRESS COVER HORIZONTAL <b>molex</b> DOCUMENT NO. SD-31414-860 SHEET NO. 1 OF 1	
SEE CHART THIS DRAWING CONTAINS INFORMATION THAT IS PROPRIETARY TO MOLEX INCORPORATED AND SHOULD NOT BE USED WITHOUT WRITTEN PERMISSION											