

REV.	DESCRIPTION	DATE	APPROVED
A	Engineering Release.	07/18/14	J. C.

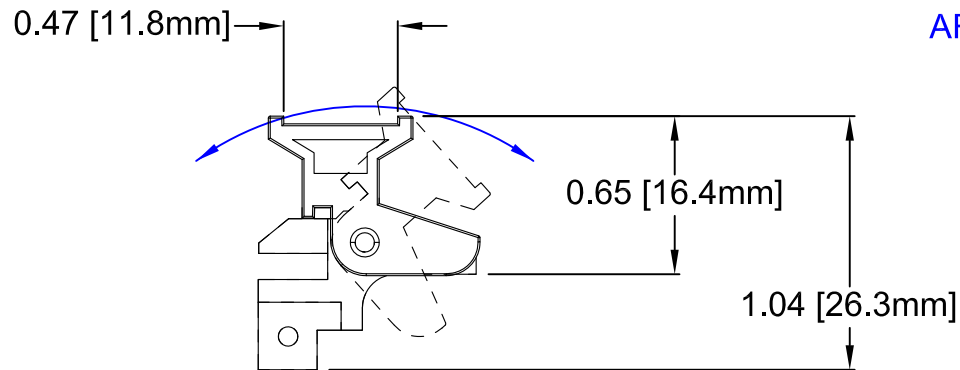

AREA FOR MARKING

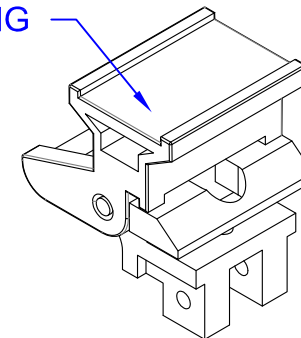

3D VIEW

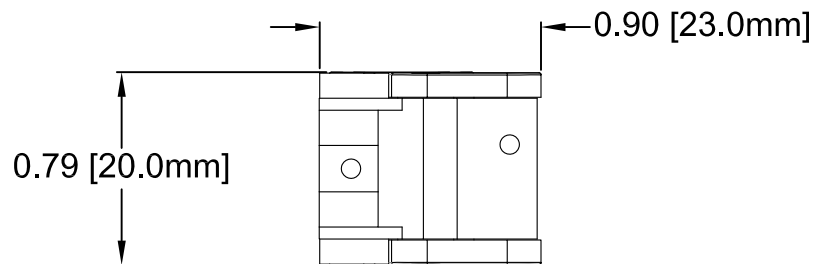

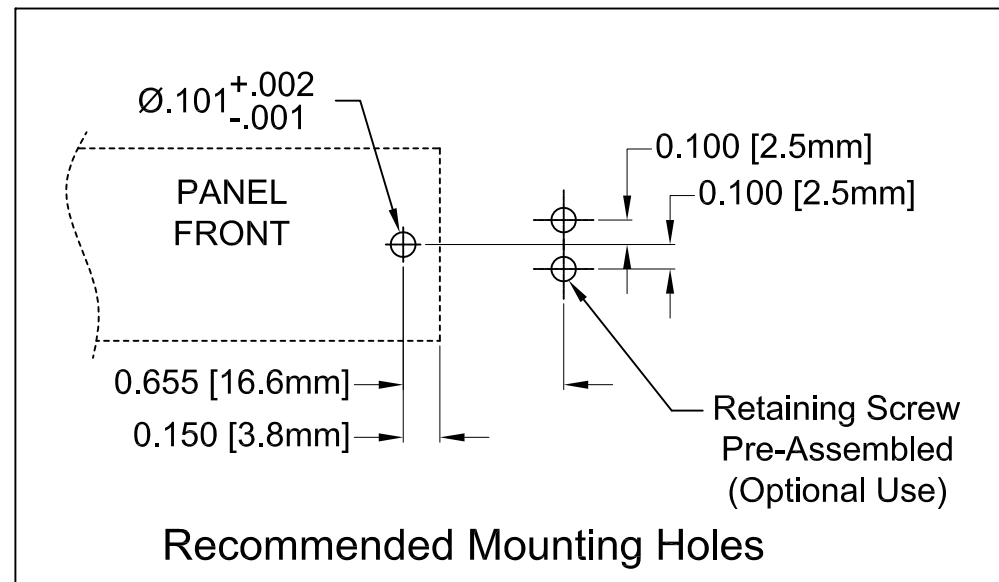

**ORDERING INFORMATION:**  
 CPCI-E6GY: GRAY COLOR  
 CPCI-E6BK: BLACK COLOR



Recommended Mounting Holes

**NOTES:**

1. Compliant with PICMG CPCI standard
2. Mounting screws shipped unassembled

STANDARD TOLERANCE ( UNLESS OTHERWISE SPECIFIED )		 4 THOMAS, IRVINE, CA, 92618 TEL: (949) 951-8808 FAX: (949) 951-3974	
DECIMALS	ANGULAR		
.X ± .1	X° ± 1°	 <b>TITLE: CPCI EJECTOR HANDLE STYLE E6</b>	
.XX ± .01			
.XXX ± .005			
DESIGNED: <b>Brian Oliver</b>	DATE: <b>07/18/14</b>	<b>PART NO:</b> CPCI-E6XX	REVISION: <b>A</b>
CHECKED: <b>A. Wright</b>	DATE: <b>07/18/14</b>	<b>CAGE CODE : 32559</b>	<b>SHEET # 1 OF 1</b>
CAD GENERATED DOCUMENT, DO NOT MEASURE DRAWING.			