

NHD-1.5-128128G

Graphic Color OLED Display

NHD-	Newhaven Display
1.5-	1.5" Diagonal Size
128128-	128 x 128 Pixels
G-	OLED Glass

Newhaven Display International, Inc.

2661 Galvin Ct.

Elgin IL, 60124

Ph: 847-844-8795

Fax: 847-844-8796

www.newhavendisplay.com

nhtech@newhavendisplay.com

nhsales@newhavendisplay.com

Document Revision History

Revision	Date	Description	Changed by
-	01/15/19	Initial Release	PB
1	05/08/20	Added clarification to Vdd (Pin 26) In the Pinout Description	AS

Functions and Features

- 128 x 128 pixel resolution
- Built-in SSD1351 controller
- Parallel or Serial MPU interface
- RoHS compliant

SYMBOL	REVISION	DATE

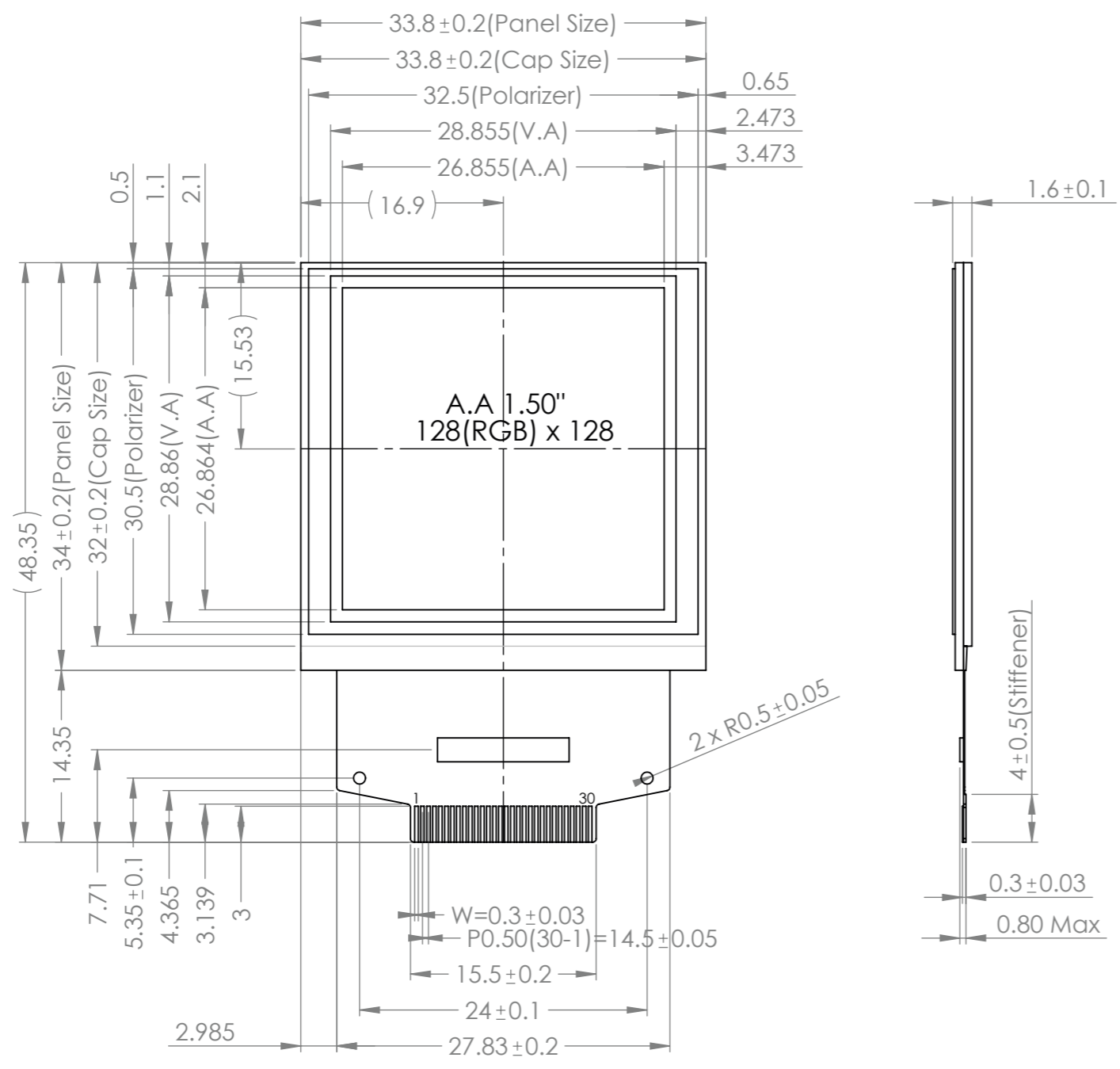

Pin Assignment

Pin	Symbol
1	N.C. (GND)
2	VCC
3	VCOMH
4	VDDIO
5	VSL
6	N.C.
7	D7
8	D6
9	D5
10	D4
11	D3
12	D2
13	D1
14	D0
15	E/RD#
16	R/W#
17	BS0
18	BS1
19	CS#
20	D/C#
21	RES#
22	IREF
23	GPIO1
24	GPIO0
25	N.C.
26	VDD
27	VCI
28	VSS
29	N.C.
30	N.C. (GND)

- Notes:**
- Display Type: 1.5" Color OLED Glass, FFC Connection
 - Driver IC: SSD1351
 - Supply Voltage:
 - Logic (V_{DD}) = 2.5V
 - Display (V_{CC}) = 13V
 - Interface: 8-Bit 68XX/80XX Parallel, 3/4-wire SPI
 - Operating Temp: $-40^{\circ}\text{C} - +70^{\circ}\text{C}$
 - Storage Temp: $-40^{\circ}\text{C} - +85^{\circ}\text{C}$

STANDARD TOLERANCE: (UNLESS OTHERWISE SPECIFIED)			
LINEAR: $\pm 0.3\text{mm}$			
DRAWING/PART NUMBER: NHD-1.5-128128G		REVISION: 1.1	
DRAWN BY: A. Shah		APPROVED BY: A. Shah	
DRAWN DATE: 5/8/20		APPROVED DATE: 5/8/20	
UNLESS OTHERWISE SPECIFIED: - DIMENSIONS ARE IN MILLIMETERS - THIRD ANGLE PROJECTION		SIZE: A3 SCALE: 2:1	
DO NOT SCALE DRAWING		SHEET 1 OF 1	
THIS DRAWING IS SOLELY THE PROPERTY OF NEWHAVEN DISPLAY INTERNATIONAL, INC. THE INFORMATION IT CONTAINS IS NOT TO BE DISCLOSED, REPRODUCED OR COPIED IN WHOLE OR PART WITHOUT WRITTEN APPROVAL FROM NEWHAVEN DISPLAY.			

Interface Description

Pin No.	Symbol	External Connection	Function Description
1	NC (GND)	-	No connect (can be tied to Ground)
2	V _{CC}	Power Supply	Supply voltage for OLED panel
3	V _{COMH}	Power Supply	Output voltage for COM signal
4	V _{DDIO}	Power Supply	Supply voltage for I/O pins
5	V _{SL}	Power Supply	Output voltage for SEG signal
6	NC	-	No connect
7	D7	MPU	Parallel interface: 8-bit bi-directional data bus Serial interface: D0 = Serial Clock signal (SCLK) D1 = Serial Data Input signal (SDIN)
8	D6	MPU	
9	D5	MPU	
10	D4	MPU	
11	D3	MPU	
12	D2	MPU	
13	D1	MPU	
14	D0	MPU	
15	E /RD	MPU	6800 mode: Enable signal. Falling edge triggered 8080 mode: Active LOW Read signal
16	R/W /WR	MPU	6800 mode: Read/Write signal. LOW: Write. HIGH: Read 8080 mode: Active LOW Write signal
17	BS0	MPU	MPU interface select signal
18	BS1	MPU	MPU interface select signal
19	/CS	MPU	Active LOW Chip Select signal
20	D/C	MPU	Register Select signal. LOW: Command. HIGH: Data
21	/RES	MPU	Active LOW Reset signal
22	I _{REF}	Power Supply	Output current reference for brightness adjustment
23	GPIO1	MPU	See command 0xB5 (can be treated as a no connect)
24	GPIO0	MPU	See command 0xB5 (can be treated as a no connect)
25	NC	-	No connect
26	V _{DD}	Power Supply	Supply voltage for Logic (generated internally from V _{Cl}) Connect 1μF cap to GND.
27	V _{Cl}	Power Supply	Supply voltage for Operation
28	V _{SS}	Power Supply	Ground
29	NC	-	No connect
30	NC (GND)	-	No connect (can be tied to Ground)

Recommended display connector: 30pin 0.5mm pitch top contact FFC connector (Molex 54104-3033 or equivalent)

MPU Interface Pin Assignment Summary

Bus Interface	D7	D6	D5	D4	D3	D2	D1	D0	E	R/W	BS0	BS1	/CS	D/C	/RES	GPIO1	GPIO0
8-bit 6800	D[7:0]								E	R/W	1	1	/CS	D/C	/RES	NC	NC
8-bit 8080	D[7:0]								/RD	/WR	0	1	/CS	D/C	/RES	NC	NC
4-wire SPI	0				NC	SDIN	SCLK	0	0	0	0	/CS	D/C	/RES	NC	NC	
3-wire SPI	0				NC	SDIN	SCLK	0	0	1	0	/CS	0	/RES	NC	NC	

Note:

- “NC” : No Connect
- “1” : VDD
- “0” : VSS

Wiring Diagram

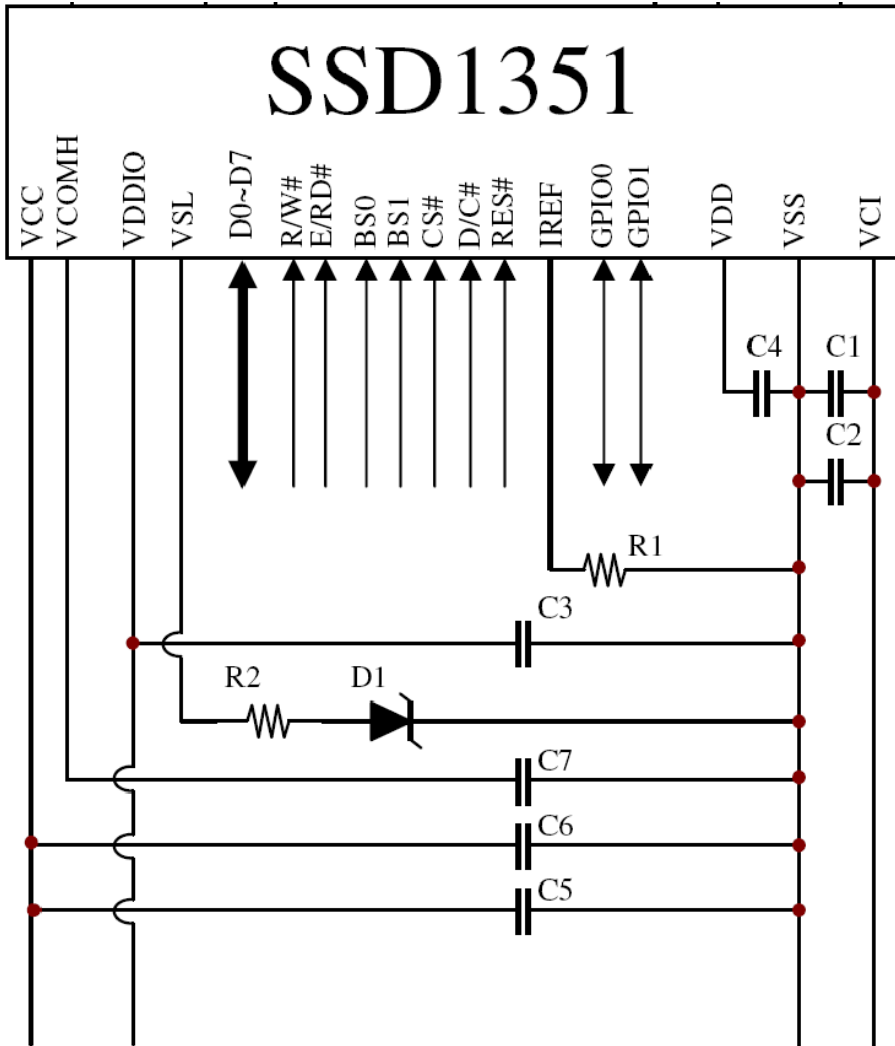

MCU Interface Selection: BS0 and BS1
 Pins connected to MCU interface: D7~D0, E/RD#, R/W#, CS#, D/C#, and RES#

- C1, C5 : 0.1 μ F
- C2 : 4.7 μ F
- C6 : 10 μ F
- C3, C4: 1 μ F
- C7 : 4.7 μ F / 25V Tantalum Capacitor
- R1 : 560k Ω , $R1 = (\text{Voltage at IREF} - VSS) / IREF$
- R2 : 50 Ω , 1/4W
- D1 : \approx 1.4V, 0.5W

Electrical Characteristics

Item	Symbol	Condition	Min.	Typ.	Max.	Unit
Operating Temperature Range	T _{OP}	Absolute Max	-40	-	+70	°C
Storage Temperature Range	T _{ST}	Absolute Max	-40	-	+85	°C
Supply Voltage for Logic	V _{DD}	-	2.4	2.5	2.6	V
Supply Voltage for I/O pins	V _{DDIO}	-	1.65	1.8	V _{CI}	V
Supply Voltage for Operation	V _{CI}	-	2.4	2.8	3.5	V
Supply Voltage for Display	V _{CC}	-	12.5	13	13.5	V
Supply Current (Logic)	I _{CC}	V _{CC} =13V, 50% ON	-	23.2	29.0	mA
		V _{CC} =13V, 100% ON	-	33.4	42.0	mA
Supply Current (Display)	I _{CI}	-	-	240	300	μA
Supply Current (Sleep)	I _{CI, SLEEP}	V _{CI} = 2.8V	-	4	20	μA
"H" Level input	V _{IH}	-	0.8 * V _{DDIO}	-	V _{DDIO}	V
"L" Level input	V _{IL}	-	V _{SS}	-	0.2 * V _{DDIO}	V
"H" Level output	V _{OH}	-	0.9 * V _{DDIO}	-	V _{DDIO}	V
"L" Level output	V _{OL}	-	V _{SS}	-	0.1 * V _{DDIO}	V

Optical Characteristics

Item	Symbol	Condition	Min.	Typ.	Max.	Unit
Optimal Viewing Angles	Top	-	80	-	-	°
	Bottom		80	-	-	°
	Left		80	-	-	°
	Right		80	-	-	°
Contrast Ratio	CR	-	-	>10,000:1	-	-
Response Time (rise)	T _R	-	-	10	-	μs
Response Time (fall)	T _F	-	-	10	-	μs
Brightness	L _V	50% Checkerboard	70	90	-	cd/m ²
Lifetime	-	90 cd/m ² , T _{OP} =25°C 50% Checkerboard	10,000	-	-	Hrs
		70 cd/m ² , T _{OP} =25°C 50% Checkerboard	13,500	-	-	Hrs

Note: Lifetime at typical temperature is based on accelerated high-temperature operation. Lifetime is tested at average 50% pixels on and is rated as Hours until **Half-Brightness**. The Display OFF command can be used to extend the lifetime of the display.

Luminance of active pixels will degrade faster than inactive pixels. Residual (burn-in) images may occur. To avoid this, every pixel should be illuminated uniformly.

Controller information

Built-in SSD1351 controller.

Please download specification at <http://www.newhavendisplay.com/appnotes/datasheets/OLEDs/SSD1351.pdf>

Table of Commands

(D/C# = 0, R/W#(WR#)= 0, E(RD#) = 1) unless specific setting is stated

Single byte command (D/C# = 0), Multiple byte command (D/C# = 0 for first byte, D/C# = 1 for other bytes)

Fundamental Command Table											
D/C#	Hex	D7	D6	D5	D4	D3	D2	D1	D0	Command	Description
0 1 1	15 A[6:0] B[6:0]	0 * *	0 A ₆ B ₆	0 A ₅ B ₅	1 A ₄ B ₄	0 A ₃ B ₃	1 A ₂ B ₂	0 A ₁ B ₁	1 A ₀ B ₀	Set Column Address	A[6:0]: Start Address. [reset=0] B[6:0]: End Address. [reset=127] Range from 0 to 127
0 1 1	75 A[6:0] B[6:0]	0 * *	1 A ₆ B ₆	1 A ₅ B ₅	1 A ₄ B ₄	0 A ₃ B ₃	1 A ₂ B ₂	0 A ₁ B ₁	1 A ₀ B ₀	Set Row Address	A[6:0]: Start Address. [reset=0] B[6:0]: End Address. [reset=127] Range from 0 to 127
0	5C	0	1	0	1	1	1	0	0	Write RAM Command	Enable MCU to write Data into RAM
0	5D	0	1	0	1	1	1	0	1	Read RAM Command	Enable MCU to read Data from RAM
0 1	A0 A[7:0]	1 A ₇	0 A ₆	1 A ₅	0 A ₄	0 A ₃	0 A ₂	0 A ₁	0 A ₀	Set Re-map / Color Depth (Display RAM to Panel)	<p>A[0]=0b, Horizontal address increment [reset] A[0]=1b, Vertical address increment</p> <p>A[1]=0b, Column address 0 is mapped to SEG0 [reset] A[1]=1b, Column address 127 is mapped to SEG0</p> <p>A[2]=0b, Color sequence: A → B → C [reset] A[2]=1b, Color sequence is swapped: C → B → A</p> <p>A[3]=0b, Reserved A[3]=1b, Reserved</p> <p>A[4]=0b, Scan from COM0 to COM[N-1] [reset] A[4]=1b, Scan from COM[N-1] to COM0. Where N is the Multiplex ratio.</p> <p>A[5]=0b, Disable COM Split Odd Even A[5]=1b, Enable COM Split Odd Even [reset]</p> <p>A[7:6] Set Color Depth, 00b / 01b: 65k color [reset] 10b: 262k color 11b 262k color, 16-bit format 2</p> <p>Refer to Table 8-8 for details</p>

Fundamental Command Table											
D/C#	Hex	D7	D6	D5	D4	D3	D2	D2	D0	Command	Description
0 1	A1 A[6:0]	1 *	0 A ₆	1 A ₅	0 A ₄	0 A ₃	0 A ₂	0 A ₁	1 A ₀	Set Display Start Line	Set vertical scroll by RAM from 0~127. [reset=00h]
0 1	A2 A[6:0]	1 *	0 A ₆	1 A ₅	0 A ₄	0 A ₃	0 A ₂	1 A ₁	0 A ₀	Set Display Offset	Set vertical scroll by Row from 0-127. [reset=60h] Note (¹) This command is locked by Command FDh by default. To unlock it, please refer to Command FDh.
0	A4~A7	1	0	1	0	0	1	X ₁	X ₀	Set Display Mode	A4h: All OFF A5h: All ON (All pixels have GS63) A6h : Reset to normal display [reset] A7h: Inverse Display (GS0 -> GS63, GS1 -> GS62,)
0 1	AB A[7:0]	1 A ₇	0 A ₆	1 0	0 0	1 0	0 0	1 0	1 A ₀	Function Selection	A[0]=0b, Select external V _{DD} A[0]=1b, Enable internal V _{DD} regulator [reset] A[7:6]=00b, Select 8-bit parallel interface [reset] A[7:6]=01b, Select 16-bit parallel interface A[7:6]=11b, Select 18-bit parallel interface
0	AD	1	0	1	0	1	1	0	1	NOP	Command for no operation.
0	AE~AF	1	0	1	0	1	1	1	X ₀	Set Sleep mode ON/OFF	AEh = Sleep mode On (Display OFF) AFh = Sleep mode OFF (Display ON)
0	B0	1	0	1	1	0	0	0	0	NOP	Command for no operation.
0 1	B1 A[7:0]	1 A ₇	0 A ₆	1 A ₅	1 A ₄	0 A ₃	0 A ₂	0 A ₁	1 A ₀	Set Reset (Phase 1) / Pre-charge (Phase 2) period	A[3:0] Phase 1 period of 5~31 DCLK(s) clocks [reset=0010b] A[3:0]: 0-1 invalid 2 = 5 DCLKs 3 = 7 DCLKs : 15 = 31DCLKs A[7:4] Phase 2 period of 3~15 DCLK(s) clocks [reset=1000b] A[7:4]: 0-2 invalid 3 = 3 DCLKs 4 = 4 DCLKs : 15 =15DCLKs Note (¹) 0 DCLK is invalid in phase 1 & phase 2 (²) This command is locked by Command FDh by default. To unlock it, please refer to Command FDh.

Fundamental Command Table																																					
D/C#	Hex	D7	D6	D5	D4	D3	D2	D2	D0	Command	Description																										
0	B2	1	0	1	1	0	0	1	0	Display Enhancement	A[7:0] = 00h, B[7:0] = 00h, C[7:0] = 00h normal [reset] A[7:0] = A4h, B[7:0] = 00h, C[7:0] = 00h enhance display performance																										
1	A[7:0]	A ₇	A ₆	A ₅	A ₄	A ₃	A ₂	A ₁	A ₀																												
1	B[7:0]	0	0	0	0	0	0	0	0																												
1	C[7:0]	0	0	0	0	0	0	0	0																												
0	B3	1	0	1	1	0	0	1	1	Front Clock Divider (DivSet)/ Oscillator Frequency	A[3:0] [reset=0001], divide by DIVSET where <table border="1" style="margin-left: auto; margin-right: auto;"> <thead> <tr> <th>A[3:0]</th> <th>DIVSET</th> </tr> </thead> <tbody> <tr><td>0000</td><td>divide by 1</td></tr> <tr><td>0001</td><td>divide by 2</td></tr> <tr><td>0010</td><td>divide by 4</td></tr> <tr><td>0011</td><td>divide by 8</td></tr> <tr><td>0100</td><td>divide by 16</td></tr> <tr><td>0101</td><td>divide by 32</td></tr> <tr><td>0110</td><td>divide by 64</td></tr> <tr><td>0111</td><td>divide by 128</td></tr> <tr><td>1000</td><td>divide by 256</td></tr> <tr><td>1001</td><td>divide by 512</td></tr> <tr><td>1010</td><td>divide by 1024</td></tr> <tr><td>>=1011</td><td>invalid</td></tr> </tbody> </table> A[7:4] Oscillator frequency, frequency increases as level increases [reset=1101b] Note (1) This command is locked by Command FDh by default. To unlock it, please refer to Command FDh.	A[3:0]	DIVSET	0000	divide by 1	0001	divide by 2	0010	divide by 4	0011	divide by 8	0100	divide by 16	0101	divide by 32	0110	divide by 64	0111	divide by 128	1000	divide by 256	1001	divide by 512	1010	divide by 1024	>=1011	invalid
A[3:0]	DIVSET																																				
0000	divide by 1																																				
0001	divide by 2																																				
0010	divide by 4																																				
0011	divide by 8																																				
0100	divide by 16																																				
0101	divide by 32																																				
0110	divide by 64																																				
0111	divide by 128																																				
1000	divide by 256																																				
1001	divide by 512																																				
1010	divide by 1024																																				
>=1011	invalid																																				
1	A[7:0]	A ₇	A ₆	A ₅	A ₄	A ₃	A ₂	A ₁	A ₀																												
0	B4	1	0	1	1	0	1	0	0	Set Segment Low Voltage (VSL)	A[1:0]=00 External VSL [reset] A[1:0]=01,10,11 are invalid Note (1) When external VSL is enabled, in order to avoid distortion in display pattern, an external circuit is needed to connect between VSL and V _{SS} as shown in Figure 14-1.																										
1	A[7:0]	1	0	1	0	0	0	A ₁	A ₀																												
1	B[7:0]	1	0	1	1	0	1	0	1																												
1	C[7:0]	0	1	0	1	0	1	0	1																												
0	B5	1	0	1	1	0	1	0	1	Set GPIO	A[1:0] GPIO0: 00 pin HiZ, Input disabled 01 pin HiZ, Input enabled 10 pin output LOW [reset] 11 pin output HIGH A[3:2] GPIO1: 00 pin HiZ, Input disabled 01 pin HiZ, Input enabled 10 pin output LOW [reset] 11 pin output HIGH																										
1	A[3:0]	*	*	*	*	A ₃	A ₂	A ₁	A ₀																												
0	B6	1	0	1	1	0	1	0	0	Set Second Pre-charge Period	A[3:0] Set Second Pre-charge Period 0000b invalid 0001b 1 DCLKS 0010b 2 DCLKS 1000 8 DCLKS [reset] 1111 15 DCLKS																										
1	A[3:0]	*	*	*	*	A ₃	A ₂	A ₁	A ₀																												

Fundamental Command Table																													
D/C#	Hex	D7	D6	D5	D4	D3	D2	D2	D0	Command	Description																		
0	B8	1	0	1	1	1	0	0	0	Look Up Table for Gray Scale Pulse width	<p>The next 63 data bytes define Gray Scale (GS) Table by setting the gray scale pulse width in unit of DCLK's (ranges from 0d ~ 180d)</p> <p>A1[7:0]: Gamma Setting for GS1, A2[7:0]: Gamma Setting for GS2, : A62[7:0]: Gamma Setting for GS62, A63[7:0]: Gamma Setting for GS63</p> <p>Note ⁽¹⁾ $0 \leq \text{Setting of GS1} < \text{Setting of GS2} < \text{Setting of GS3} \dots < \text{Setting of GS62} < \text{Setting of GS63}$ ⁽²⁾ GS0 has only pre-charge but no current drive stages. ⁽³⁾ GS1 can be set as only pre-charge but no current drive stage by input gamma setting for GS1 equals 0.</p>																		
1	A1[7:0]	A1 ₇	A1 ₆	A1 ₅	A1 ₄	A1 ₃	A1 ₂	A1 ₁	A1 ₀																				
1	A2[7:0]	A2 ₇	A2 ₆	A2 ₅	A2 ₄	A2 ₃	A2 ₂	A2 ₁	A2 ₀																				
1																				
1																				
1																				
1	A62[7:0]	A62 ₇	A62 ₆	A62 ₅	A62 ₄	A62 ₃	A62 ₂	A62 ₁	A62 ₀																				
1	A63[7:0]	A63 ₇	A63 ₆	A63 ₅	A63 ₄	A63 ₃	A63 ₂	A63 ₁	A63 ₀																				
0	B9	1	0	1	1	1	0	0	1			Use Built-in Linear LUT [reset= linear]	Reset to default Look Up Table: GS1 = 0 DCLK GS2 = 2 DCLK GS3 = 4 DCLK GS4 = 6 DCLK ... GS62 = 122 DCLK GS63 = 124 DCLK																
0	BB	1	0	1	1	1	0	1	1			Set Pre-charge voltage	Set pre-charge voltage level.[reset = 17h]																
1	A[4:0]	0	0	0	A ₄	A ₃	A ₂	A ₁	A ₀																				
											<table border="1"> <thead> <tr> <th>A[4:0]</th> <th>Hex code</th> <th>pre-charge voltage</th> </tr> </thead> <tbody> <tr> <td>00000</td> <td>00h</td> <td>0.20 x V_{CC}</td> </tr> <tr> <td>:</td> <td>:</td> <td>:</td> </tr> <tr> <td>11111</td> <td>1Fh</td> <td>0.60 x V_{CC}</td> </tr> </tbody> </table> <p>Note ⁽¹⁾ This command is locked by Command FDh by default. To unlock it, please refer to Command FDh.</p>	A[4:0]	Hex code	pre-charge voltage	00000	00h	0.20 x V _{CC}	:	:	:	11111	1Fh	0.60 x V _{CC}						
A[4:0]	Hex code	pre-charge voltage																											
00000	00h	0.20 x V _{CC}																											
:	:	:																											
11111	1Fh	0.60 x V _{CC}																											
0	BE	1	0	1	1	1	1	1	0	Set V _{COMH} Voltage	Set COM deselect voltage level [reset = 05h]																		
1	A[2:0]	0	0	0	0	0	A ₂	A ₁	A ₀																				
											<table border="1"> <thead> <tr> <th>A[2:0]</th> <th>Hex code</th> <th>V_{COMH}</th> </tr> </thead> <tbody> <tr> <td>000</td> <td>00h</td> <td>0.72 x V_{CC}</td> </tr> <tr> <td>:</td> <td>:</td> <td>:</td> </tr> <tr> <td>101</td> <td>05h</td> <td>0.82 x V_{CC} [reset]</td> </tr> <tr> <td>:</td> <td>:</td> <td>:</td> </tr> <tr> <td>111</td> <td>07h</td> <td>0.86 x V_{CC}</td> </tr> </tbody> </table> <p>Note ⁽¹⁾ This command is locked by Command FDh by default. To unlock it, please refer to Command FDh.</p>	A[2:0]	Hex code	V _{COMH}	000	00h	0.72 x V _{CC}	:	:	:	101	05h	0.82 x V _{CC} [reset]	:	:	:	111	07h	0.86 x V _{CC}
A[2:0]	Hex code	V _{COMH}																											
000	00h	0.72 x V _{CC}																											
:	:	:																											
101	05h	0.82 x V _{CC} [reset]																											
:	:	:																											
111	07h	0.86 x V _{CC}																											

Fundamental Command Table											
D/C#	Hex	D7	D6	D5	D4	D3	D2	D1	D0	Command	Description
0	C1	1	1	0	0	0	0	0	1	Set Contrast Current for Color A,B,C	A[7:0] Contrast Value Color A [reset=10001010b]
1	A[7:0]	A ₇	A ₆	A ₅	A ₄	A ₃	A ₂	A ₁	A ₀		B[7:0] Contrast Value Color B [reset=01010001b]
1	B[7:0]	B ₇	B ₆	B ₅	B ₄	B ₃	B ₂	B ₁	B ₀		C[7:0] Contrast Value Color C [reset=10001010b]
1	C[7:0]	C ₇	C ₆	C ₅	C ₄	C ₃	C ₂	C ₁	C ₀		
0	C7	1	1	0	0	0	1	1	1	Master Contrast Current Control	A[3:0] :
1	A[3:0]	*	*	*	*	A ₃	A ₂	A ₁	A ₀		0000b reduce output currents for all colors to 1/16 0001b reduce output currents for all colors to 2/16 1110b reduce output currents for all colors to 15/16 1111b no change [reset]
0	CA	1	1	0	0	1	0	1	0	Set MUX Ratio	A[6:0] MUX ratio 16MUX ~ 128MUX, [reset=127], (Range from 15 to 127)
1	A[6:0]	0	A ₆	A ₅	A ₄	A ₃	A ₂	A ₁	A ₀		
0	D1	1	0	1	0	1	1	0	1	NOP	Command for No Operation
0	E3	1	1	1	0	0	0	1	1	NOP	Command for No Operation
0	FD	1	1	1	1	1	1	0	1	Set Command Lock	A[7:0]: MCU protection status [reset = 12h] A[7:0] = 12b, Unlock OLED driver IC MCU interface from entering command [reset] A[7:0] = 16b, Lock OLED driver IC MCU interface from entering command
1	A[7:0]	A ₇	A ₆	A ₅	A ₄	A ₃	A ₂	A ₁	A ₀		A[7:0] = B0b, Command A2,B1,B3,BB,BE,C1 inaccessible in both lock and unlock state [reset] A[7:0] = B1b, Command A2,B1,B3,BB,BE,C1 accessible if in unlock state
											Note (1) The locked OLED driver IC MCU interface prohibits all commands and memory access except the FDh command.

Set (GAC) (D/C# = 0, R/W#(WR#)= 0, E(RD#) = 1) unless specific setting is stated

Single byte command (D/C# = 0), Multiple byte command (D/C# = 0 for first byte, D/C# = 1 for other bytes)

Graphic acceleration command											
D/C#	Hex	D7	D6	D5	D4	D3	D2	D1	D0	Command	Description
0	96	1	0	0	1	0	1	1	0	Horizontal Scroll	A[7:0] = 00000000b No scrolling
1	A[7:0]	A ₇	A ₆	A ₅	A ₄	A ₃	A ₂	A ₁	A ₀		A[7:0] = 00000001b to 00111111b Scroll towards SEG127 with 1 column offset
1	B[6:0]	0	B ₆	B ₅	B ₄	B ₃	B ₂	B ₁	B ₀		A[7:0] = 01000000b to 11111111b Scroll towards SEG0 with 1 column offset
1	C[7:0]	C ₇	C ₆	C ₅	C ₄	C ₃	C ₂	C ₁	C ₀		
1	D[6:0]	0	D ₆	D ₅	D ₄	D ₃	D ₂	D ₁	D ₀		B[6:0] : start row address
1	E[1:0]	0	0	0	0	0	0	E ₁	E ₀		C[7:0] : number of rows to be H-scrolled B+C <= 128
											D[6:0] : Reserved (reset=00h)
											E[1:0] : scrolling time interval 00b test mode 01b normal 10b slow 11b slowest
											Note (1) Operates during display ON.
0	9E	1	0	0	1	1	1	1	0	Stop Moving	Stop horizontal scroll
											Note (1) After sending 9Eh command to stop the scrolling action, the ram data needs to be rewritten
0	9F	1	0	0	1	1	1	1	1	Start Moving	Start horizontal scroll

Note

(1) After executed the graphic command, waiting time is required for update GDDRAM content.

V_{CI} = 2.4~3.5V, waiting time = 500ns/pixel.

Timing Characteristics

6800-Series MCU Parallel Interface:

Symbol	Parameter	Min	Typ	Max	Unit
t_{CYCLE}	Clock Cycle Time (read) Clock Cycle Time (write)	320 300	-	-	ns
t_{AS}	Address Setup Time	24	-	-	ns
t_{AH}	Address Hold Time	0	-	-	ns
t_{DSW}	Write Data Setup Time	40	-	-	ns
t_{DHW}	Write Data Hold Time	7	-	-	ns
t_{DHR}	Read Data Hold Time	20	-	-	ns
t_{OH}	Output Disable Time	-	-	70	ns
t_{ACC}	Access Time	-	-	140	ns
PW_{CSL}	Chip Select Low Pulse Width (read) Chip Select Low Pulse Width (write)	120 60	-	-	ns
PW_{CSH}	Chip Select High Pulse Width (read) Chip Select High Pulse Width (write)	60 60	-	-	ns
t_R	Rise Time	-	-	15	ns
t_F	Fall Time	-	-	15	ns

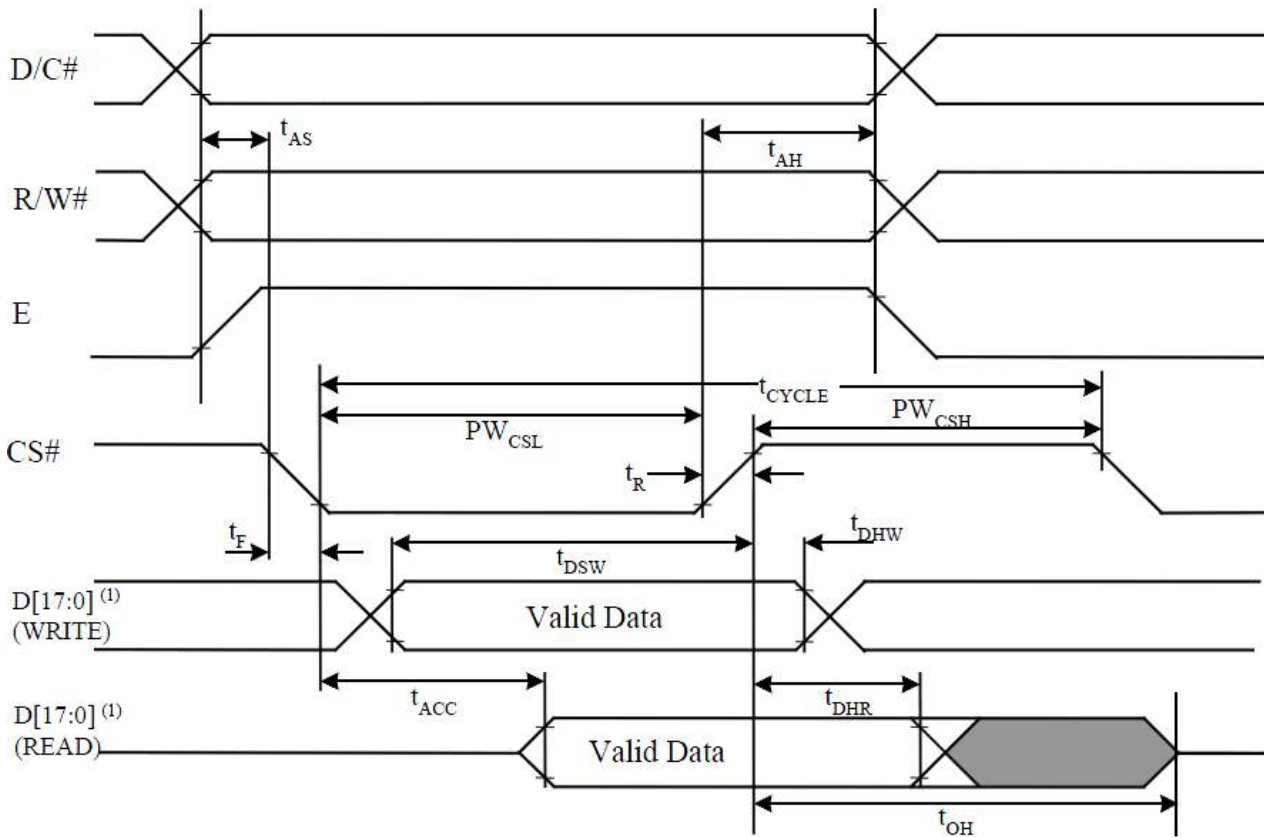

8080-Series MCU Parallel Interface:

Symbol	Parameter	Min	Typ	Max	Unit
t_{CYCLE}	Clock Cycle Time	300	-	-	ns
t_{AS}	Address Setup Time	10	-	-	ns
t_{AH}	Address Hold Time	0	-	-	ns
t_{DSW}	Write Data Setup Time	40	-	-	ns
t_{DHW}	Write Data Hold Time	7	-	-	ns
t_{DHR}	Read Data Hold Time	20	-	-	ns
t_{OH}	Output Disable Time	-	-	46	ns
t_{ACC}	Access Time	-	-	140	ns
t_{PWLW}	Read Low Time	150	-	-	ns
t_{PWLW}	Write Low Time	60	-	-	ns
t_{PWHR}	Read High Time	60	-	-	ns
t_{PWHR}	Write High Time	60	- <td -	ns	
t_{R}	Rise Time	-	-	15	ns
t_{F}	Fall Time	-	-	15	ns
t_{CS}	Chip select setup time	0	-	-	ns
t_{CSH}	Chip select hold time to read signal	0	-	-	ns
t_{CSF}	Chip select hold time	20	-	-	ns

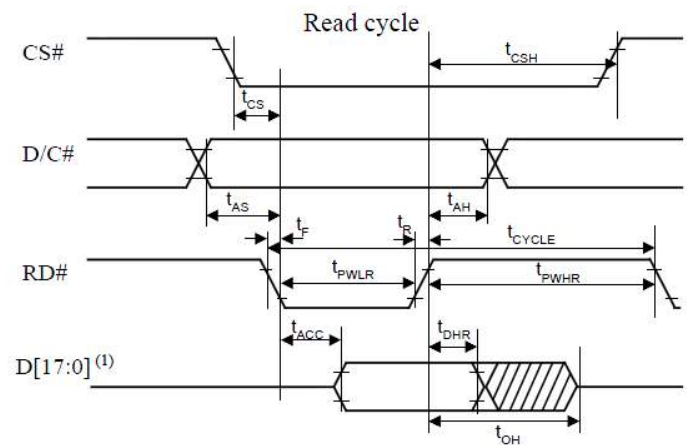
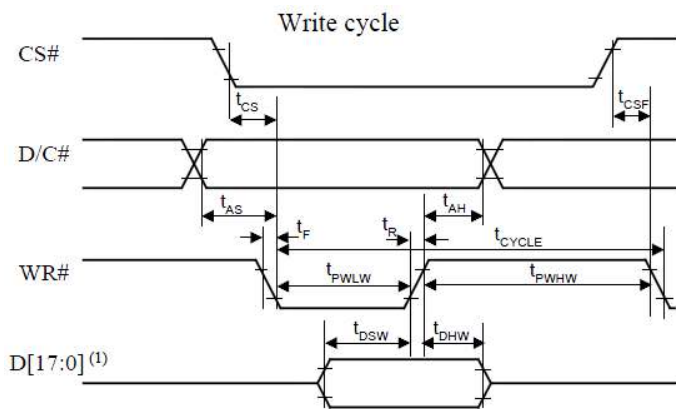

4-wire SPI:

Symbol	Parameter	Min	Typ	Max	Unit
t_{cycle}	Clock Cycle Time	220	-	-	ns
t_{AS}	Address Setup Time	15	-	-	ns
t_{AH}	Address Hold Time	42	-	-	ns
t_{CSS}	Chip Select Setup Time	20	-	-	ns
t_{CSH}	Chip Select Hold Time	10	-	-	ns
t_{DSW}	Write Data Setup Time	15	-	-	ns
t_{DHW}	Write Data Hold Time	20	-	-	ns
t_{CLKL}	Clock Low Time	20	-	-	ns
t_{CLKH}	Clock High Time	20	-	-	ns
t_R	Rise Time	-	-	15	ns
t_F	Fall Time	-	-	15	ns

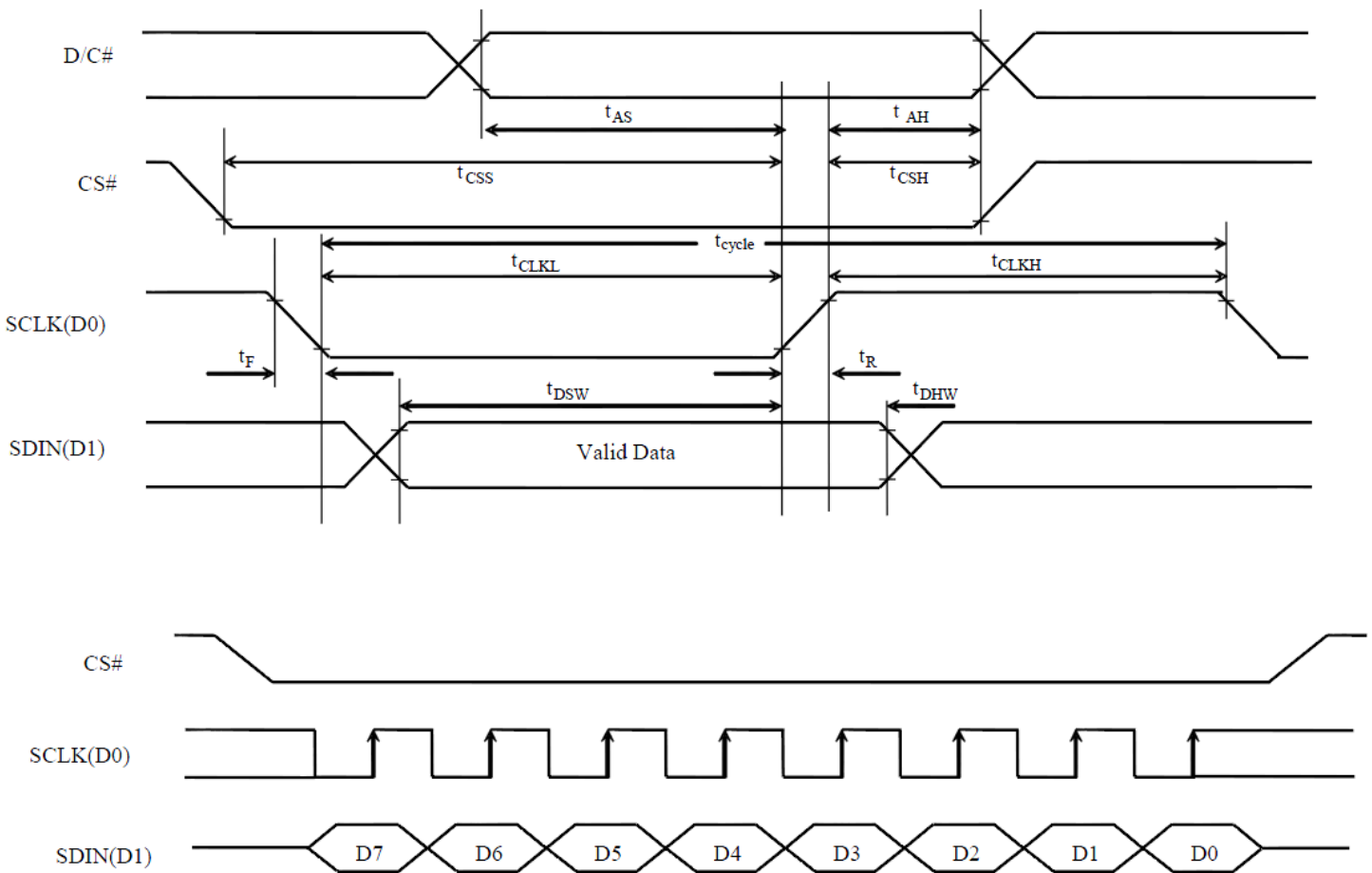

3-wire SPI:

Symbol	Parameter	Min	Typ	Max	Unit
t_{cycle}	Clock Cycle Time	220	-	-	ns
t_{CSS}	Chip Select Setup Time	20	-	-	ns
t_{CSH}	Chip Select Hold Time	44	-	-	ns
t_{DSW}	Write Data Setup Time	15	-	-	ns
t_{DHW}	Write Data Hold Time	20	-	-	ns
t_{CLKL}	Clock Low Time	20	-	-	ns
t_{CLKH}	Clock High Time	20	-	-	ns
t_{R}	Rise Time	-	-	15	ns
t_{F}	Fall Time	-	-	15	ns

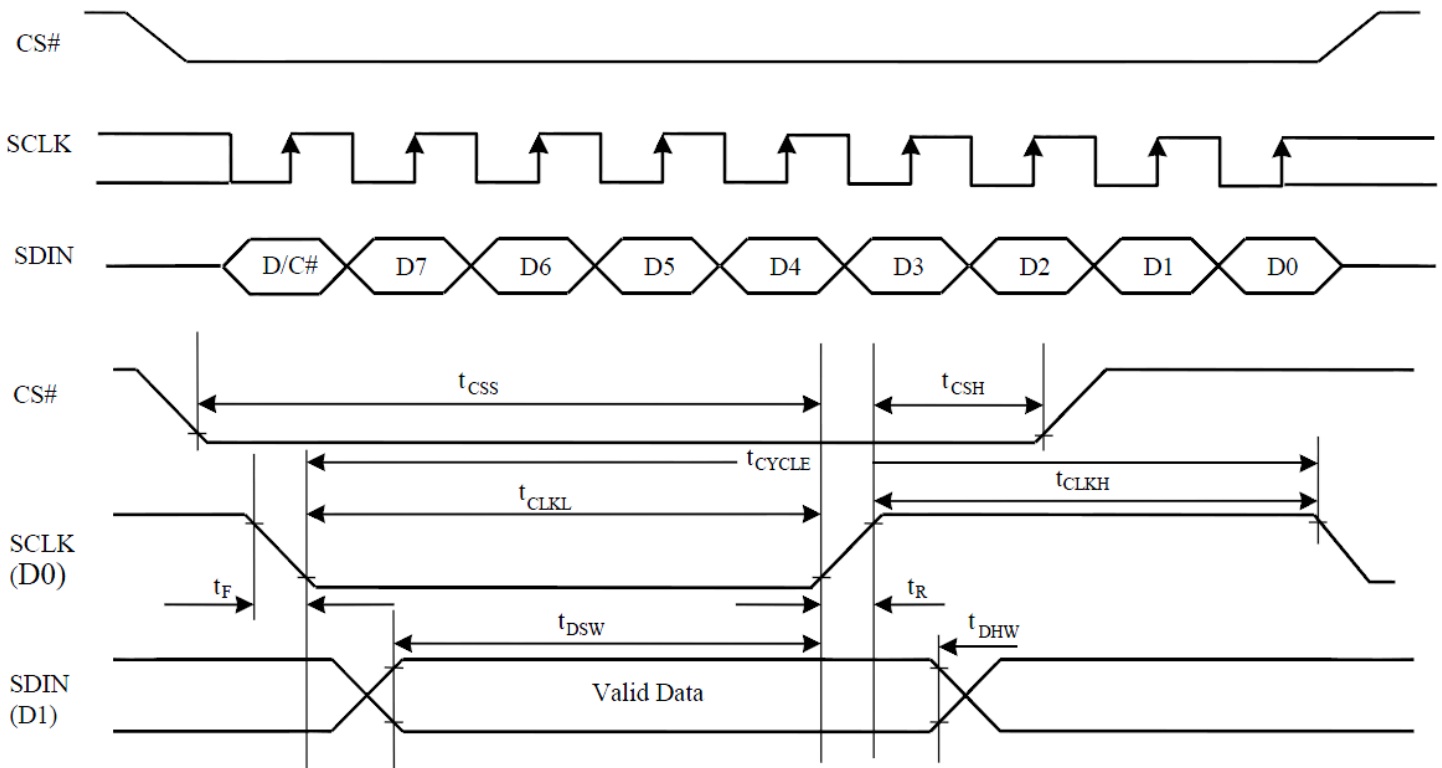

Example Initialization Sequence:

```
void OLED_Init_128128RGB(void)
{
  GPIO_ResetBits(RES_pin);
  delay_ms(300);
  GPIO_SetBits(RES_pin);
  delay_ms(10);

  oled_Command_128128RGB(0xFD); //Command lock setting
  oled_Data_128128RGB(0x12); //unlock
  oled_Command_128128RGB(0xFD); //Command lock setting
  oled_Data_128128RGB(0xB1); //unlock

  oled_Command_128128RGB(0xAE); //Set Display OFF

  oled_Command_128128RGB(0xB3); //Set Display Clock Divide Ratio
  oled_Data_128128RGB(0xF1);

  oled_Command_128128RGB(0xCA); //Set MUX ratio
  oled_Data_128128RGB(0x7F);

  oled_Command_128128RGB(0xA2); //Set Display offset
  oled_Data_128128RGB(0x00);

  oled_Command_128128RGB(0xA1); //Set display start line
  oled_Data_128128RGB(0x00);

  oled_Command_128128RGB(0xA0); //Set Re-map, color depth
  oled_Data_128128RGB(0xB4);

  oled_Command_128128RGB(0xB5); //set GPIO
  oled_Data_128128RGB(0x00);

  oled_Command_128128RGB(0xAB); //Function Set
  oled_Data_128128RGB(0x01);

  oled_Command_128128RGB(0xB4); //Set Segment Low Voltage
  oled_Data_128128RGB(0xA0);
  oled_Data_128128RGB(0xB5);
  oled_Data_128128RGB(0x55);

  oled_Command_128128RGB(0xC1); //Set Contrast Current
  oled_Data_128128RGB(0xC8);
  oled_Data_128128RGB(0x80);
  oled_Data_128128RGB(0xC8);

  oled_Command_128128RGB(0xC7); //Master Contrast Current Control
  oled_Data_128128RGB(0x0F);

  oled_Command_128128RGB(0xB9); //use linear grayscale LUT

  oled_Command_128128RGB(0xB1); //Set Phase Length
  oled_Data_128128RGB(0x32);
```

```
oled_Command_128128RGB(0xBB); //Set Pre-charge Voltage
oled_Data_128128RGB(0x17);

oled_Command_128128RGB(0xB2); //Display enhancement
oled_Data_128128RGB(0xa4);
oled_Data_128128RGB(0x00);
oled_Data_128128RGB(0x00);

oled_Command_128128RGB(0xB6); //Set Second Pre-charge Period
oled_Data_128128RGB(0x01);

oled_Command_128128RGB(0xBE); //Set VCOMH
oled_Data_128128RGB(0x05);

oled_Command_128128RGB(0xA6); //Normal display

oled_Clear_Screen(); //Clear Display (write all 0x00's to display RAM)

oled_Command_128128RGB(0xAF); //Set Display ON

delay_ms(200);

oled_Command_128128RGB(0x5C); //Enable Write to RAM command
}
```

Quality Information

Test Item	Content of Test	Test Condition	Note
High Temperature storage	Test the endurance of the display at high storage temperature.	+85°C, 96hrs	2
Low Temperature storage	Test the endurance of the display at low storage temperature.	-40°C, 96hrs	1,2
High Temperature Operation	Test the endurance of the display by applying electric stress (voltage & current) at high temperature.	+70°C, 96hrs	2
Low Temperature Operation	Test the endurance of the display by applying electric stress (voltage & current) at low temperature.	-40°C, 96hrs	1,2
High Temperature / Humidity Operation	Test the endurance of the display by applying electric stress (voltage & current) at high temperature with high humidity.	+60°C, 90% RH, 96hrs	1,2
Thermal Shock resistance	Test the endurance of the display by applying electric stress (voltage & current) during a cycle of low and high temperatures.	-30°C,30min -> 25°C,5min -> 70°C,30min = 1 cycle 100 cycles	
Vibration test	Test the endurance of the display by applying vibration to simulate transportation and use.	10-22Hz , 15mm amplitude. 22-500Hz, 1.5G 30min in each of 3 directions X,Y,Z	3
Atmospheric Pressure test	Test the endurance of the display by applying atmospheric pressure to simulate transportation by air.	115mbar, 40hrs	3
Static electricity test	Test the endurance of the display by applying electric static discharge.	VS=800V, RS=1.5kΩ, CS=100pF One time	

Note 1: No condensation to be observed.

Note 2: Conducted after 2 hours of storage at 25°C, 0%RH.

Note 3: Test performed on product itself, not inside a container.

Evaluation Criteria:

- 1: Display is fully functional during operational tests and after all tests, at room temperature.
- 2: No observable defects.
- 3: Luminance >50% of initial value.
- 4: Current consumption within 50% of initial value

Precautions for using OLEDs/LCDs/LCMs

See Precautions at www.newhavendisplay.com/specs/precautions.pdf

Warranty Information

See Terms & Conditions at http://www.newhavendisplay.com/index.php?main_page=terms