

DESCRIPTION

Demonstration circuit 560 is a constant-frequency step-down converter, using the LTC3403 monolithic synchronous buck regulator. It is specifically designed for WCDMA power amplifier applications. The output voltage can be dynamically controlled from 0.3V to 3.5V. A 0.2Ω internal bypass P-channel MOSFET connects the V_{OUT} to V_{IN} reducing the power loss through the buck regulator. DC560 is capable of delivering up to 600mA of output current for an input voltage range of 2.7V to 5V. The efficiency of the DC560 is very high: up to 96%. In Burst Mode™ operation, the DC supply current is typi-

cally only 20 μ A at no load, and less than 1 μ A in shut-down.

The LTC3403 comes in a small 8-Pin DFN package and has an operating frequency of 1.5MHz (allowing the exclusive use of low profile surface mount components).

These and other features make demonstration circuit 560 ideal for single-cell Li-ion-powered hand-held applications.

Design files for this circuit board are available. Call the LTC factory.

QUICK START PROCEDURE

Demonstration circuit 560 is easy to set up to evaluate the performance of the LTC3403EDD. Refer to Figure 1 for proper measurement equipment setup and follow the procedure below:

NOTE: When measuring the input or output voltage ripple, care must be taken to avoid a long ground lead on the oscilloscope probe. Measure the input or output voltage ripple by touching the probe tip directly across the V_{in} or V_{out} and GND terminals. See Figure 2 for proper scope probe technique.

1. Place jumper JP2 in the FC position, JP1 in the ON position.
2. With power off, connect the input power supply V_{IN} to V_{IN} and GND.
3. Connect input power supply V_{REF} to REF and GND.
4. Turn on the power at V_{IN} .

NOTE: Make sure that the input voltage at V_{IN} does not exceed 5V.

5. Turn on the V_{REF} power supply.

NOTE: Make sure that the input voltage V_{REF} does not exceed V_{IN} .

6. For $V_{REF} < 1.2V$, check for the output voltages $V_{OUT} = 3 \cdot V_{REF}$
7. For $V_{REF} > 1.2V$, V_{OUT} is directly connected to V_{IN} . $V_{OUT} = V_{IN}$.

If there is no output, temporarily disconnect the load to make sure that the load is not set too high.

8. Once the proper output voltages are established, adjust the loads within 600mA range and observe the output voltage regulation, ripple voltage, efficiency and other parameters.
9. To test Burst Mode™ operation, set JP2 in the Burst position and JP1 in the ON position, and repeat steps 2 to 7.

QUICK START GUIDE FOR DEMONSTRATION CIRCUIT 560

WCDMA CELLULAR PHONE BUCK REGULATOR

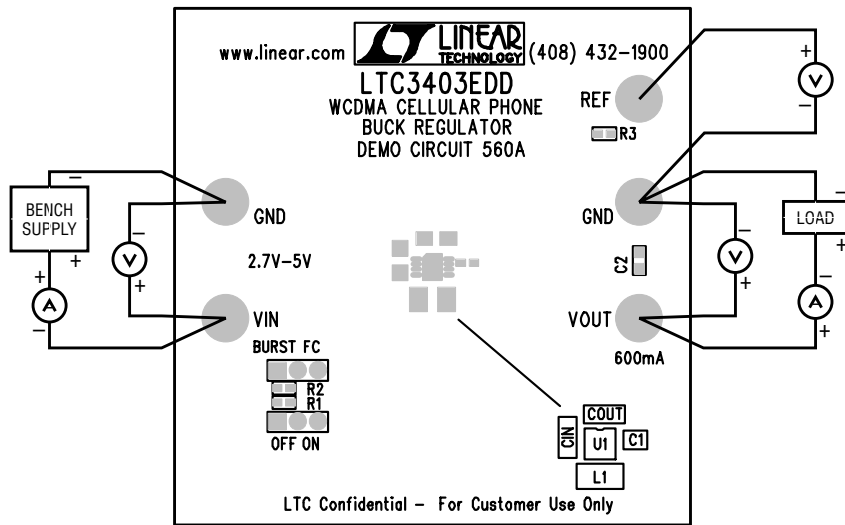

Figure 1. Proper Measurement Equipment Setup

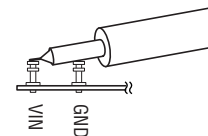

Figure 2. Scope Probe Placement for Measuring Input or Output Ripple

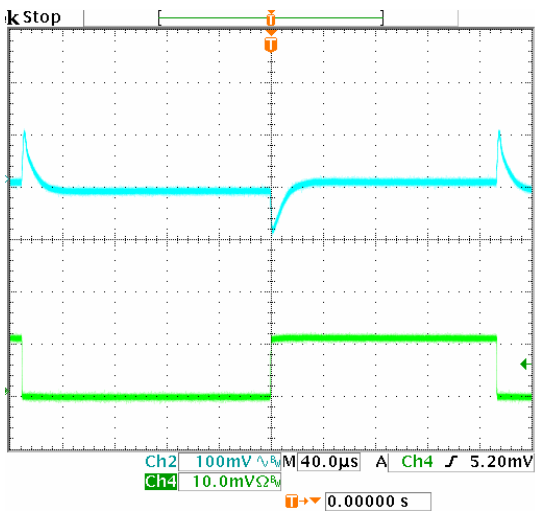

Figure 3. Ch1: VOUT (100mV / Div) Transient Response for 0 to 600mA load Step. Ch2: IOUT (500mA / Div) ($V_{IN} = 3.3V$, $V_{OUT} = 1.2V$)

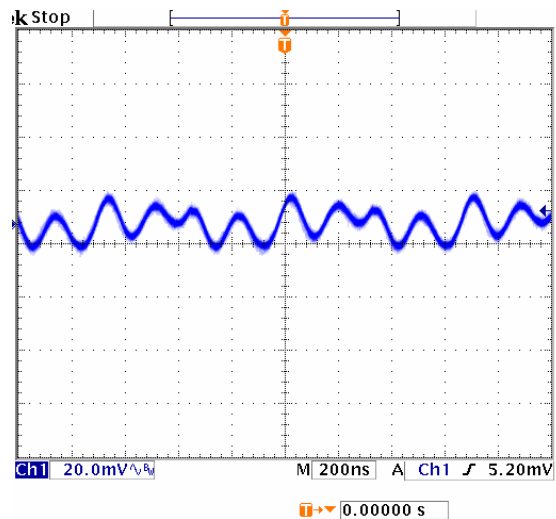
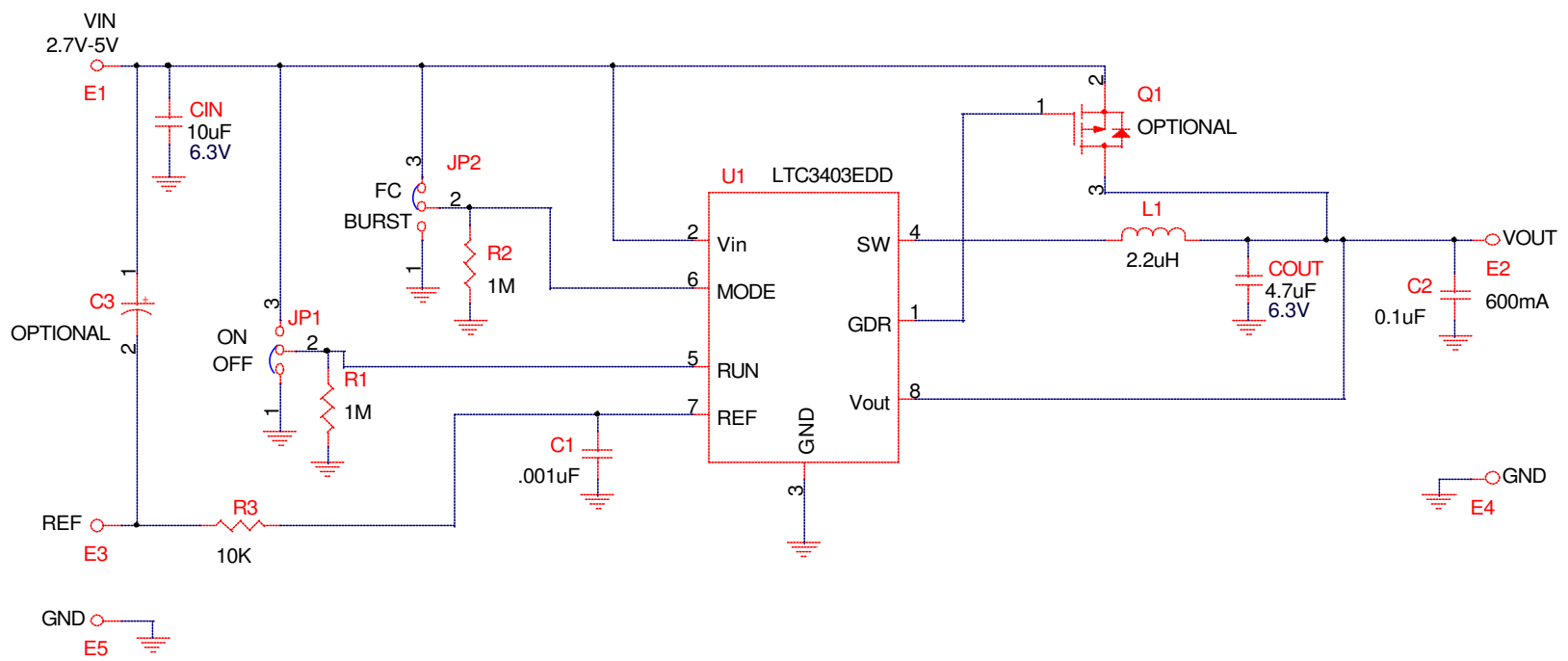



Figure 4. 1.5V Output Ripple ($V_{IN} = 3.3V$, $I_{OUT} = 600mA$)

REVISION HISTORY				
ECO	REV	DESCRIPTION	DATE	APPROVED
	3	PROTO	07/30/02	



CONTRACT NO.		 LINEAR TECHNOLOGY <small>1630 McCarthy Blvd. Milpitas, CA 95035 Phone: (408)432-1900 Fax: (408)434-0507</small>							
APPROVALS									
DRAWN	MEI	DATE	07/30/02	TITLE LTC3403EDD, WCDMA CELLULAR PHONE BUCK REGULATOR					
CHECKED									
APPROVED									
ENGINEER									
DESIGNER				SIZE	CAGE CODE	DWG NO	DC560A	REV	3
Thursday, December 12, 2002		SCALE:	FILENAME:	560A-3.DSN	SHEET	1	OF	1	