

Evaluating the **ADXL377** 3-Axis Accelerometer

GENERAL DESCRIPTION

The EVAL-ADXL377Z is a simple evaluation board that allows quick evaluation of the performance of the **ADXL377** high-*g* 3-axis accelerometer. The EVAL-ADXL377Z has a 6-pin, 0.1 inch spaced header for access to all power and signal lines that the user can attach to a prototyping board (breadboard) or to a wire using a standard plug. Four holes are provided for

mechanical attachment of the EVAL-ADXL377Z to the application.

The dimensions of the EVAL-ADXL377Z are 20.3 mm × 20.3 mm (0.8 inch × 0.8 inch). Four 3.05 mm diameter (0.12 inch) mounting holes are arranged in a 14.5 mm × 14.5 mm (0.575 inch × 0.575 inch) square around the center of the printed circuit board (PCB).

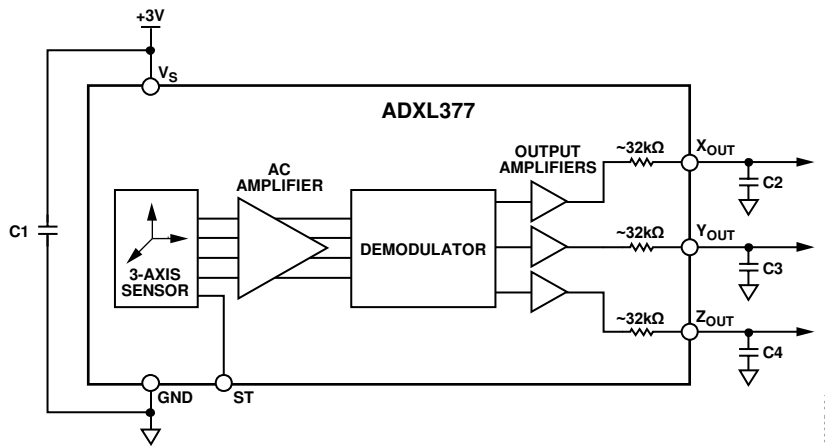

Figure 1. Schematic

09605-001

TABLE OF CONTENTS

General Description	1	Circuit Description.....	3
Revision History	2	Special Notes on Handling	3

REVISION HISTORY

9/12—Revision 0: Initial Version

CIRCUIT DESCRIPTION

The schematic of the EVAL-ADXL377Z is shown in Figure 1. The [ADXL377](#) can be operated using a supply voltage ranging from 1.8 V to 3.6 V and draws 300 μ A at a 3 V supply.

Analog bandwidth can be set by changing the C2, C3, and C4 capacitors. See the [ADXL377](#) data sheet for a complete description of the operation of the accelerometer.

The board layout of the EVAL-ADXL377Z is shown in Figure 2. The EVAL-ADXL377Z has four factory-installed capacitors (see Figure 1). C1 (100 nF) at V_S is a bypass capacitor to reduce supply noise. C2, C3, and C4 at X_{OUT} , Y_{OUT} , and Z_{OUT} , respectively, are filter capacitors (10 nF) to set the bandwidth to 500 Hz.

Some applications may require a different bandwidth, in which case C2, C3, and C4 can be changed as appropriate. See the [ADXL377](#) data sheet for a complete description of the operation of the accelerometer.

A resistor, R1, (4.02 k Ω) is included to pull ST up to V_S .

SPECIAL NOTES ON HANDLING

The EVAL-ADXL377Z is not reverse polarity protected. Reversing the positive supply (V_S) and ground (GND) pins can cause damage to the [ADXL377](#).

Dropping the EVAL-ADXL377Z on a hard surface can generate an acceleration that may exceed the data sheet absolute maximum limits of 10,000 g. See the [ADXL377](#) data sheet for more information.

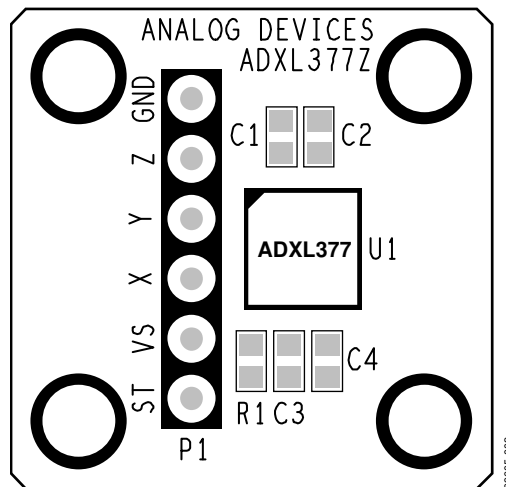

Figure 2. Physical Board Layout

NOTES

**ESD Caution**

ESD (electrostatic discharge) sensitive device. Charged devices and circuit boards can discharge without detection. Although this product features patented or proprietary protection circuitry, damage may occur on devices subjected to high energy ESD. Therefore, proper ESD precautions should be taken to avoid performance degradation or loss of functionality.

Legal Terms and Conditions

By using the evaluation board discussed herein (together with any tools, components documentation or support materials, the "Evaluation Board"), you are agreeing to be bound by the terms and conditions set forth below ("Agreement") unless you have purchased the Evaluation Board, in which case the Analog Devices Standard Terms and Conditions of Sale shall govern. Do not use the Evaluation Board until you have read and agreed to the Agreement. Your use of the Evaluation Board shall signify your acceptance of the Agreement. This Agreement is made by and between you ("Customer") and Analog Devices, Inc. ("ADI"), with its principal place of business at One Technology Way, Norwood, MA 02062, USA. Subject to the terms and conditions of the Agreement, ADI hereby grants to Customer a free, limited, personal, temporary, non-exclusive, non-sublicensable, non-transferable license to use the Evaluation Board FOR EVALUATION PURPOSES ONLY. Customer understands and agrees that the Evaluation Board is provided for the sole and exclusive purpose referenced above, and agrees not to use the Evaluation Board for any other purpose. Furthermore, the license granted is expressly made subject to the following additional limitations: Customer shall not (i) rent, lease, display, sell, transfer, assign, sublicense, or distribute the Evaluation Board; and (ii) permit any Third Party to access the Evaluation Board. As used herein, the term "Third Party" includes any entity other than ADI, Customer, their employees, affiliates and in-house consultants. The Evaluation Board is NOT sold to Customer; all rights not expressly granted herein, including ownership of the Evaluation Board, are reserved by ADI. CONFIDENTIALITY. This Agreement and the Evaluation Board shall all be considered the confidential and proprietary information of ADI. Customer may not disclose or transfer any portion of the Evaluation Board to any other party for any reason. Upon discontinuation of use of the Evaluation Board or termination of this Agreement, Customer agrees to promptly return the Evaluation Board to ADI. ADDITIONAL RESTRICTIONS. Customer may not disassemble, decompile or reverse engineer chips on the Evaluation Board. Customer shall inform ADI of any occurred damages or any modifications or alterations it makes to the Evaluation Board, including but not limited to soldering or any other activity that affects the material content of the Evaluation Board. Modifications to the Evaluation Board must comply with applicable law, including but not limited to the RoHS Directive. TERMINATION. ADI may terminate this Agreement at any time upon giving written notice to Customer. Customer agrees to return to ADI the Evaluation Board at that time. LIMITATION OF LIABILITY. THE EVALUATION BOARD PROVIDED HEREUNDER IS PROVIDED "AS IS" AND ADI MAKES NO WARRANTIES OR REPRESENTATIONS OF ANY KIND WITH RESPECT TO IT. ADI SPECIFICALLY DISCLAIMS ANY REPRESENTATIONS, ENDORSEMENTS, GUARANTEES, OR WARRANTIES, EXPRESS OR IMPLIED, RELATED TO THE EVALUATION BOARD INCLUDING, BUT NOT LIMITED TO, THE IMPLIED WARRANTY OF MERCHANTABILITY, TITLE, FITNESS FOR A PARTICULAR PURPOSE OR NON-INFRINGEMENT OF INTELLECTUAL PROPERTY RIGHTS. IN NO EVENT WILL ADI AND ITS LICENSORS BE LIABLE FOR ANY INCIDENTAL, SPECIAL, INDIRECT, OR CONSEQUENTIAL DAMAGES RESULTING FROM CUSTOMER'S POSSESSION OR USE OF THE EVALUATION BOARD, INCLUDING BUT NOT LIMITED TO LOST PROFITS, DELAY COSTS, LABOR COSTS OR LOSS OF GOODWILL. ADI'S TOTAL LIABILITY FROM ANY AND ALL CAUSES SHALL BE LIMITED TO THE AMOUNT OF ONE HUNDRED US DOLLARS (\$100.00). EXPORT. Customer agrees that it will not directly or indirectly export the Evaluation Board to another country, and that it will comply with all applicable United States federal laws and regulations relating to exports. GOVERNING LAW. This Agreement shall be governed by and construed in accordance with the substantive laws of the Commonwealth of Massachusetts (excluding conflict of law rules). Any legal action regarding this Agreement will be heard in the state or federal courts having jurisdiction in Suffolk County, Massachusetts, and Customer hereby submits to the personal jurisdiction and venue of such courts. The United Nations Convention on Contracts for the International Sale of Goods shall not apply to this Agreement and is expressly disclaimed.