

16-Bit Buffer/ Line Driver with 3-State Outputs

GENERAL DESCRIPTION

The ML65F16244 is a BiCMOS, 16-bit buffer/line driver with 3-state outputs. This device was specifically designed for high speed bus applications. Its 16 channels support propagation delay of 2ns maximum, and fast output enable and disable times of 5ns or less to minimize datapath delay.

This device is designed to minimize undershoot, overshoot, and ground bounce to decrease noise delays. These transceivers implement a unique digital and analog implementation to eliminate the delays and noise inherent in traditional digital designs. The device offers a new method for quickly charging up a bus load capacitor to minimize bus settling times, or FastBus™ Charge. FastBus Charge is a transition current, (specified as $I_{DYNAMIC}$) that injects between 60 to 200mA (depending on output load) of current during the rise time and fall time. This current is used to reduce the amount of time it takes to charge up a heavily-capacitive loaded bus, effectively reducing the bus settling times, and improving data/clock margins in tight timing budgets.

Micro Linear's solution is intended for applications for critical bus timing designs that include minimizing device propagation delay, bus settling time, and time delays due to noise. Applications include; high speed memory arrays, bus or backplane isolation, bus to bus bridging, and sub-2ns propagation delay schemes.

The ML65F16244 follows the pinout and functionality of the industry standard 2.7V to 3.6V-logic families.

FEATURES

- Low propagation delays — 2ns maximum for 3.3V, 2.5ns maximum for 2.7V
- Fast output enable/disable times of 5ns maximum
- FastBus Charge current to minimize the bus settling time during active capacitive loading
- 2.7 to 3.6V V_{CC} supply operation; LV-TTL compatible input and output levels with 3-state capability
- Industry standard pinout compatible to FCT, ALV, LCX, LVT, and other low voltage logic families
- ESD protection exceeds 2000V
- Full output swing for increased noise margin
- Undershoot and overshoot protection to 400mV typically
- Low ground bounce design

* This Part Is End Of Life As Of August 1, 2000

BLOCK DIAGRAM

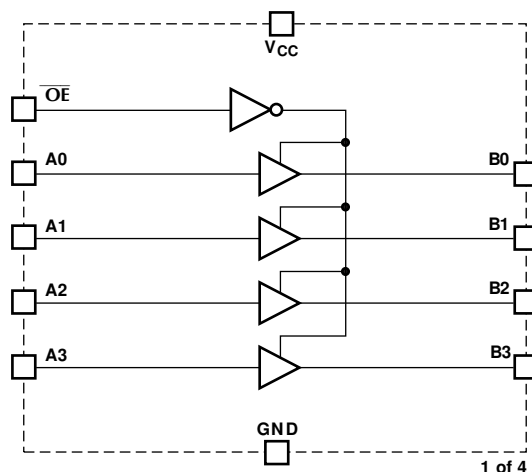

ML65F16244

PIN CONFIGURATION

ML65F16244
48-Pin SSOP (R48)
48-Pin TSSOP (T48)

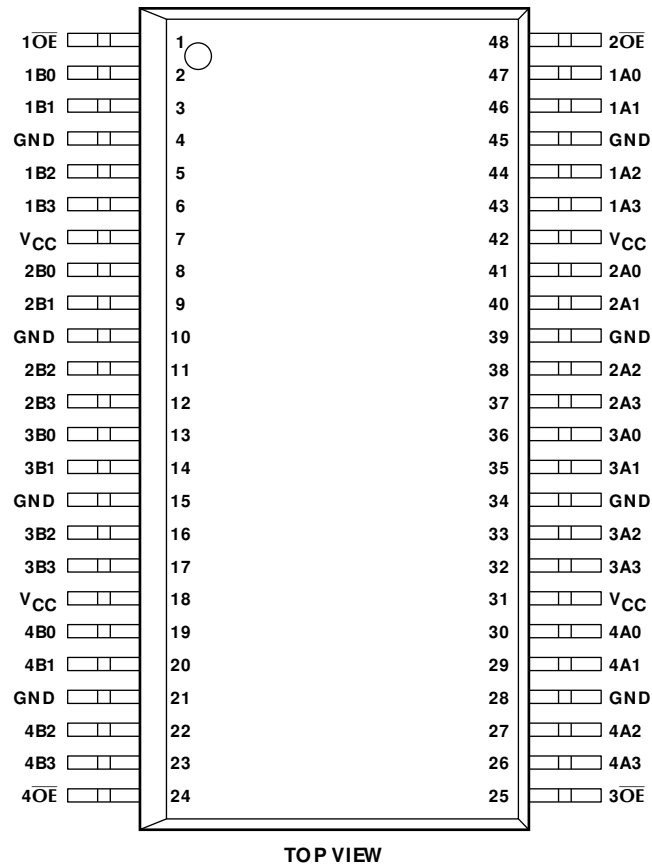

FUNCTION TABLE

(Each 4-bit section)

INPUTS		OUTPUTS
OE	1Ai, 2Ai, 3Ai, 4Ai	1Bi, 2Bi, 3Bi, 4Bi
L	H	H
L	L	L
H	X	Z

L = Logic Low, H = Logic High, X = Don't Care, Z = High Impedance

PIN DESCRIPTION

PIN	NAME	FUNCTION	PIN	NAME	FUNCTION
1	$\overline{1OE}$	Output Enable	25	$\overline{3OE}$	Output Enable
2	1B0	Data Output	26	4A3	Data Input
3	1B1	Data Output	27	4A2	Data Input
4	GND	Signal Ground	28	GND	Signal Ground
5	1B2	Data Output	29	4A1	Data Input
6	1B3	Data Output	30	4A0	Data Input
7	V _{CC}	2.7V to 3.6V Supply	31	V _{CC}	2.7V to 3.6V Supply
8	2B0	Data Output	32	3A3	Data Input
9	2B1	Data Output	33	3A2	Data Input
10	GND	Signal Ground	34	GND	Signal Ground
11	2B2	Data Output	35	3A1	Data Input
12	2B3	Data Output	36	3A0	Data Input
13	3B0	Data Output	37	2A3	Data Input
14	3B1	Data Output	38	2A2	Data Input
15	GND	Signal Ground	39	GND	Signal Ground
16	3B2	Data Output	40	2A1	Data Input
17	3B3	Data Output	41	2A0	Data Input
18	V _{CC}	2.7V to 3.6V Supply	42	V _{CC}	2.7V to 3.6V Supply
19	4B0	Data Output	43	1A3	Data Input
20	4B1	Data Output	44	1A2	Data Input
21	GND	Signal Ground	45	GND	Signal Ground
22	4B2	Data Output	46	1A1	Data Input
23	4B3	Data Output	47	1A0	Data Input
24	$\overline{4OE}$	Output Enable	48	$\overline{2OE}$	Output Enable

ML65F16244

ABSOLUTE MAXIMUM RATINGS

Absolute maximum ratings are those values beyond which the device could be permanently damaged. Absolute maximum ratings are stress ratings only and functional device operation is not implied.

V_{CC} 7V
 DC Input Voltage $-0.3V$ to $V_{CC} + 0.3V$
 AC Input Voltage (PW < 20ns) $-3.0V$
 DC Output Voltage $-0.3V$ to 7VDC
 Output Current, Source or Sink 180mA

Storage Temperature Range $-65^{\circ}C$ to $150^{\circ}C$
 Junction Temperature $150^{\circ}C$
 Lead Temperature (Soldering, 10sec) $150^{\circ}C$
 Thermal Impedance (θ_{JA}) $76^{\circ}C/W$

OPERATING CONDITIONS

Temperature Range $0^{\circ}C$ to $70^{\circ}C$
 V_{IN} Operating Range 2.7V to 3.6V

ELECTRICAL CHARACTERISTICS

Unless otherwise specified, $V_{IN} = 3.3V$, $T_A =$ Operating Temperature Range (Note 1).

SYMBOL	PARAMETER	CONDITIONS	MIN	TYP	MAX	UNITS	
AC ELECTRICAL CHARACTERISTICS ($C_{LOAD} = 50pF$)							
t_{PHL}, t_{PLH}	Propagation Delay	Ai to Bi	3.3V	1.35	1.7	2	ns
			2.7V	1.25	1.9	2.5	ns
t_{OE}	Output Enable Time	OE to Ai/Bi	3.3V			5	ns
			2.7V			6	ns
		DIR to Ai/Bi	3.3V			5	ns
			2.7V			6	ns
t_{OD}	Output Disable Time	OE to Ai/Bi	3.3V			5	ns
			2.7V			6	ns
		DIR to Ai/Bi	3.3V			5	ns
			2.7V			6	ns
T_{OS}	Output-to-Output Skew				300	ps	
C_{IN}	Input Capacitance				5	pF	

DC ELECTRICAL CHARACTERISTICS

 ($C_{LOAD} = 50pF, R_{LOAD} =$ Open)

V_{IH}	Input High Voltage	Logic high	2.0			V
V_{IL}	Input Low Voltage	Logic low			0.8	V
I_{IH}	Input High Current	Per pin, $V_{IN} = 3V$			300	mA
I_{IL}	Input Low Current	Per pin, $V_{IN} = 0V$			300	mA
I_{HI-Z}	Three-State Output Current	$V_{CC} = 3.6V, 0 < V_{IN} < V_{CC}$			5	mA
V_{IC}	Input Clamp Voltage	$V_{CC} = 3.6V, I_{IN} = 18mA$		-0.7	-0.2	V
$I_{DYNAMIC}$	Dynamic Transition Current (FastBus Charge)	Low to high transitions		80		mA
		High to low transitions		80		mA
V_{OH}	Output High Voltage	$V_{CC} = 3.6V$	2.4	3.4		V
		$V_{CC} = 2.7V$	2.25	2.35		V
V_{OL}	Output Low Voltage	$V_{CC} = 2.7V$ and $3.6V$			0.6	V
I_{CC}	Quiescent Power Supply Current	$V_{CC} = 3.6V, f = 0Hz,$ Inputs = V_{CC} or $0V$			3	μA

Note 1: Limits are guaranteed by 100% testing, sampling, or correlation with worst-case test conditions.

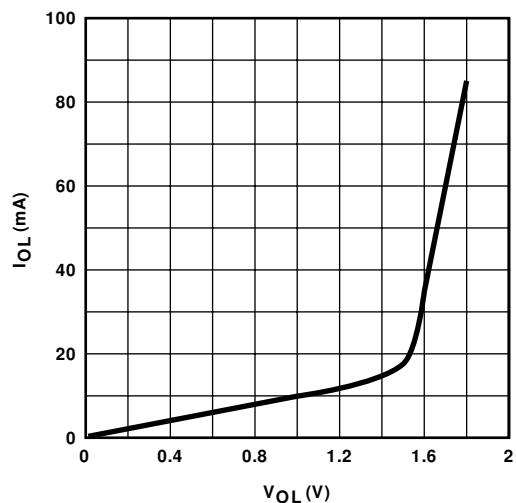

Figure 1a. Typical V_{OL} vs I_{OL} for 3.3V V_{CC} . One Buffer Output

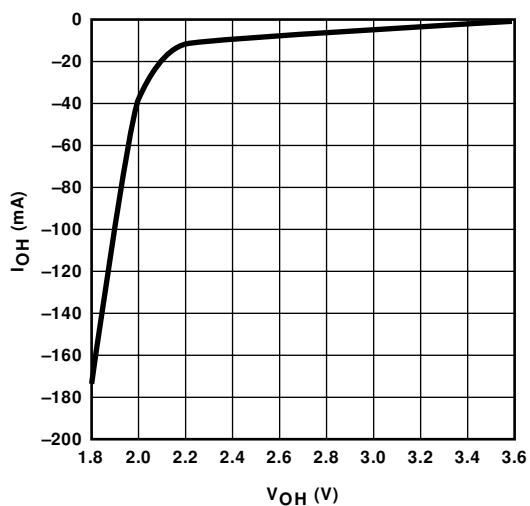

Figure 1b. Typical V_{OH} vs I_{OH} for 3.3V V_{CC} . One Buffer Output

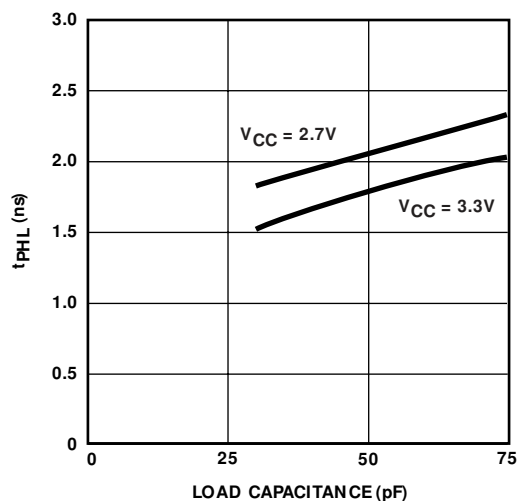

Figure 2a. Propagation Delay vs. Load Capacitance: 3.3V, 50MHZ

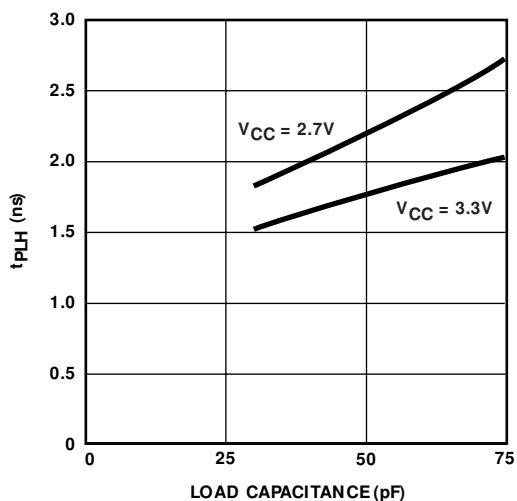

Figure 2b. Propagation Delay vs. Load Capacitance: 2.7V, 50MHZ

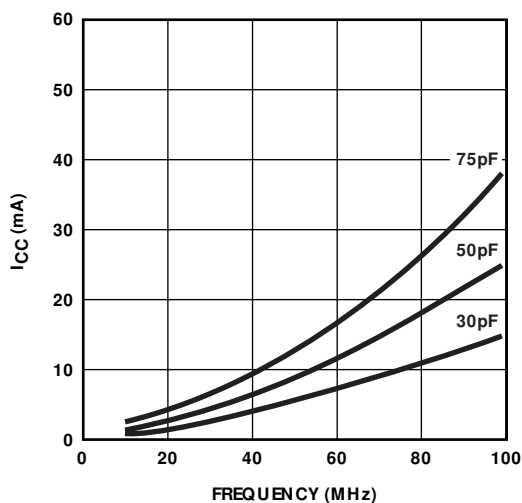

Figure 3a. I_{CC} vs. Frequency: $V_{CC} = V_{IN} = 3.3V$. One Buffer Output

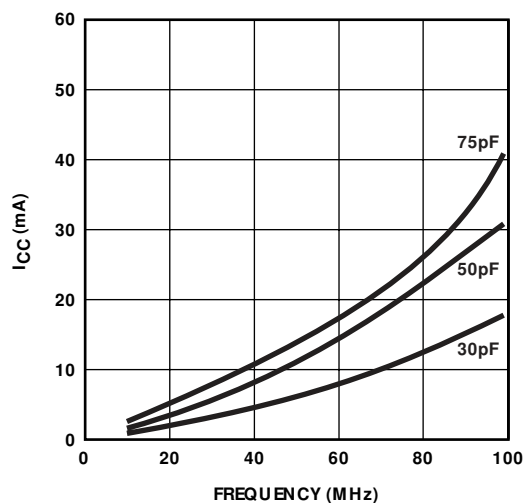

Figure 3b. I_{CC} vs. Frequency: $V_{CC} = V_{IN} = 2.7V$. One Buffer Output

FUNCTIONAL DESCRIPTION

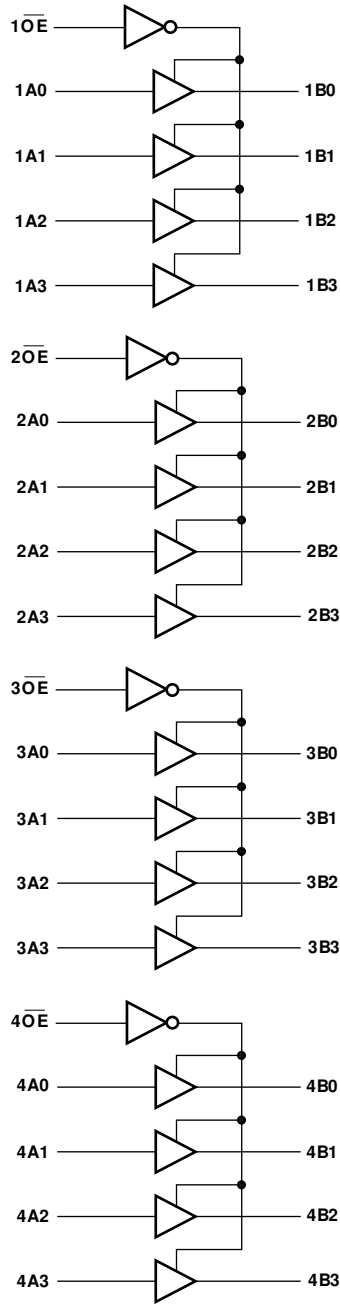

Figure 4. Logic Diagram

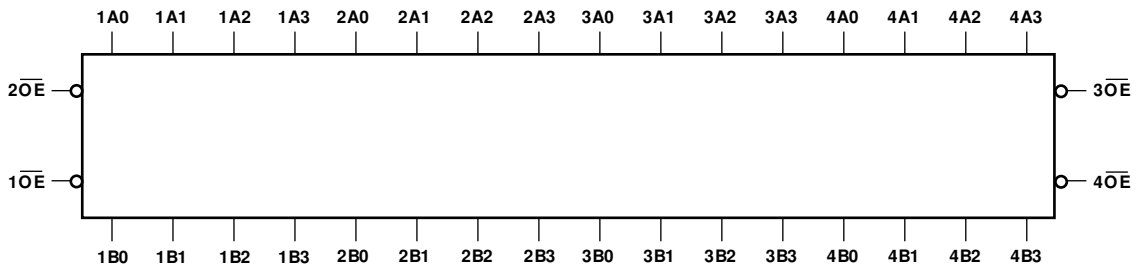

Figure 5. Logic Symbol

ARCHITECTURAL DESCRIPTION

The ML65F16244 is a 16-bit buffer/line driver with 3-state outputs designed for 2.7V to 3.6V V_{CC} operation. This device is designed for Quad-Nibble, Dual-Byte or single 16-bit word memory interleaving operations. Each bank has an independently controlled 3-state output enable pin with output enable/disable access times of less than 5ns. Each bank is configured to have four independent buffer/line drivers.

Until now, these buffer/line drivers were typically implemented in CMOS logic and made to be TTL compatible by sizing the input devices appropriately. In order to buffer large capacitances with CMOS logic, it is necessary to cascade an even number of inverters, each successive inverter larger than the preceding, eventually leading to an inverter that will drive the required load capacitance at the required frequency. Each inverter stage represents an additional delay in the gating process because in order for a single gate to switch, the input must slew more than half of the supply voltage. The best of these 16-bit CMOS buffers has managed to drive 50pF load capacitance with a delay of 3ns.

Micro Linear has produced a 16-bit buffer/line driver with a delay less than 2ns (at 3.3V) by using a unique circuit architecture that does not require cascade logic gates.

The basic architecture of the ML65F16244 is shown in Figure 6. In this circuit, there are two paths to the output.

One path sources current to the load capacitance where the signal is asserted, and the other path sinks current from the output when the signal is negated.

The assertion path is the Darlington pair consisting of transistors Q1 and Q2. The effect of transistor Q1 is to increase the current gain through the stage from input to output, to increase the input resistance and to reduce input capacitance. During an input low-to-high transition, the output transistor Q2 sources large amount of current to quickly charge up a highly capacitive load which in effect reduces the bus settling time. This current is specified as $I_{DYNAMIC}$.

The negation path is also the Darlington pair consisting of transistor Q3 and transistor Q4. With M1 connecting to the input of the Darlington pair, Transistor Q4 then sinks a large amount of current during the input transition from high-to-low.

Inverter X2 is a helpful buffer that not only drives the output toward the upper rail but also pulls the output to the lower rail.

There are a number of MOSFETs not shown in Figure 6. These MOSFETs are used to 3-state the buffers.

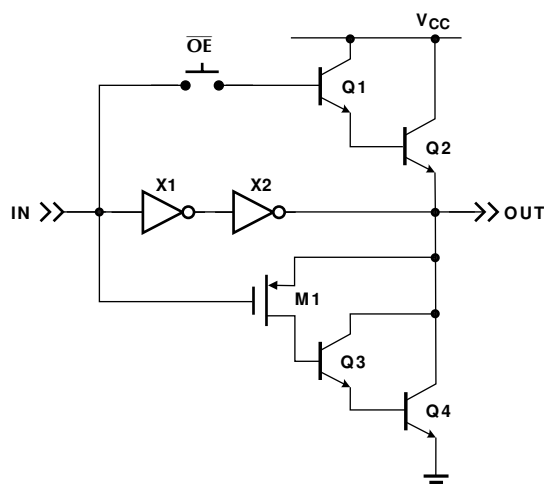

Figure 6. One Buffer Cell of the ML65F16244

CIRCUITS AND WAVE FORMS

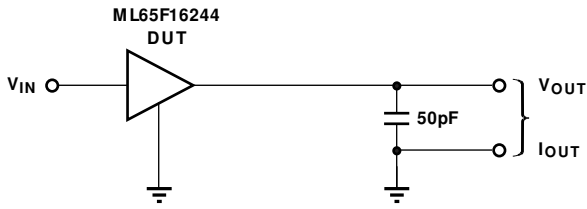

Figure 7. Test Circuits for All Outputs

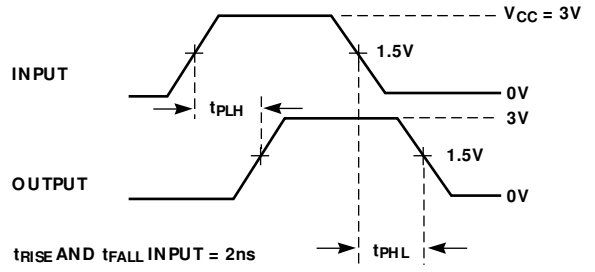

Figure 8. Propagation Delay

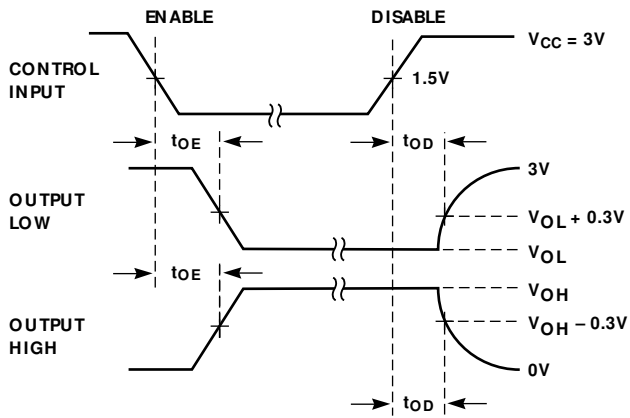

Figure 9. Enable and Disable Times

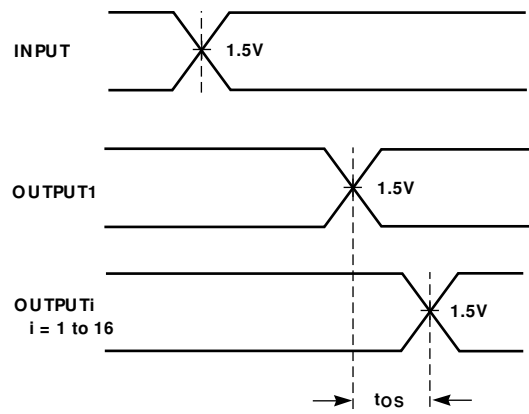
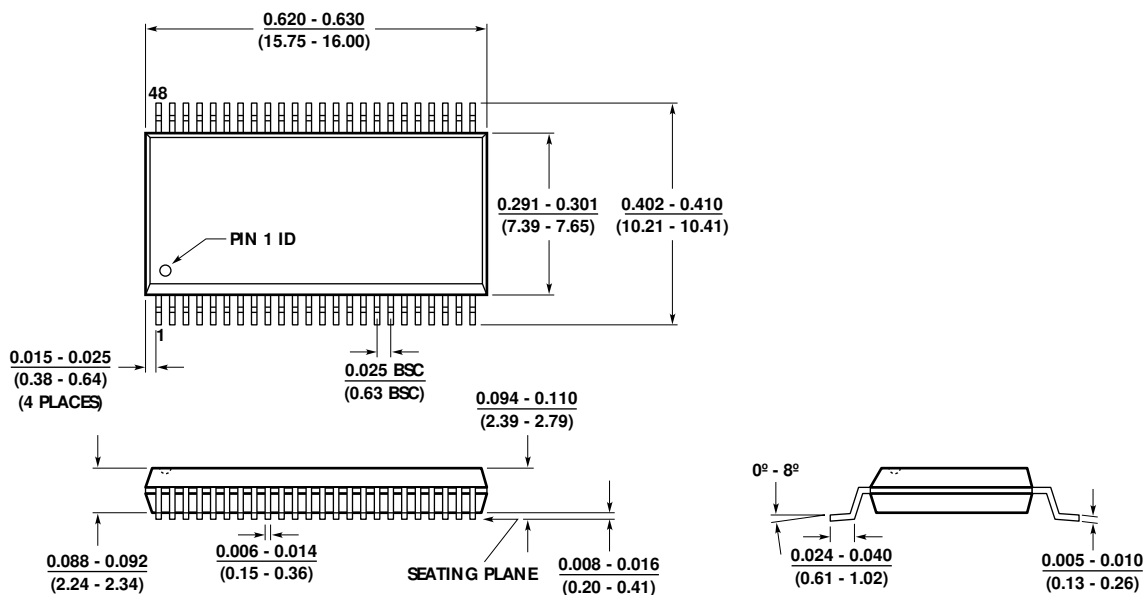

Figure 10. Output Skew

PHYSICAL DIMENSIONS inches (millimeters)

Package: R48
48-Pin SSOP



Package: T48
48-Pin TSSOP

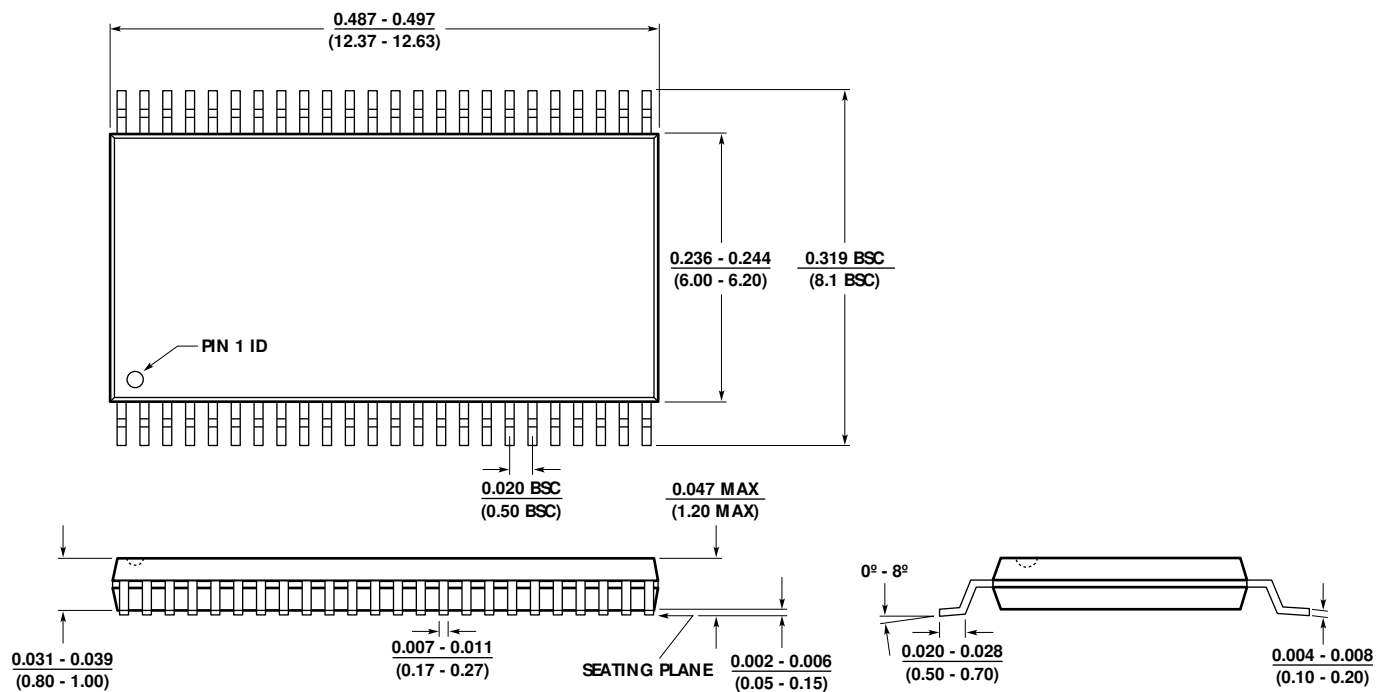

ORDERING INFORMATION

PART NUMBER	TEMPERATURE RANGE	PACKAGE
ML65F16244CR (EOL)	0°C to 70°C	48-Pin SSOP (R48)
ML65F16244CT (EOL)	0°C to 70°C	48-Pin TSSOP (T48)

DISCLAIMER

FAIRCHILD SEMICONDUCTOR RESERVES THE RIGHT TO MAKE CHANGES WITHOUT FURTHER NOTICE TO ANY PRODUCTS HEREIN TO IMPROVE RELIABILITY, FUNCTION OR DESIGN. FAIRCHILD DOES NOT ASSUME ANY LIABILITY ARISING OUT OF THE APPLICATION OR USE OF ANY PRODUCT OR CIRCUIT DESCRIBED HEREIN; NEITHER DOES IT CONVEY ANY LICENSE UNDER ITS PATENT RIGHTS, NOR THE RIGHTS OF OTHERS.

LIFE SUPPORT POLICY

FAIRCHILD'S PRODUCTS ARE NOT AUTHORIZED FOR USE AS CRITICAL COMPONENTS IN LIFE SUPPORT DEVICES OR SYSTEMS WITHOUT THE EXPRESS WRITTEN APPROVAL OF THE PRESIDENT OF FAIRCHILD SEMICONDUCTOR CORPORATION. As used herein:

1. Life support devices or systems are devices or systems which, (a) are intended for surgical implant into the body, or (b) support or sustain life, and (c) whose failure to perform when properly used in accordance with instructions for use provided in the labeling, can be reasonably expected to result in a significant injury of the user.
2. A critical component in any component of a life support device or system whose failure to perform can be reasonably expected to cause the failure of the life support device or system, or to affect its safety or effectiveness.