

NOTES:

1. MATERIALS AND FINISHES:
 BODY - STAINLESS STEEL, PASSIVATED
 CONTACT - BERYLLIUM COPPER, GOLD PLATING
 INSULATOR - PTFE
2. ELECTRICAL:
 A. IMPEDANCE: 50 OHM
 B. FREQUENCY RANGE: DC - 18 GHz
 C. VSWR(RETURN LOSS): 1.15 (-23 dB), MAX.
 D. DIELECTRIC WITHSTANDING VOLTAGE: 1000 VRMS, MIN.
3. MECHANICAL:
 A. DURABILITY: 500 CYCLES MIN.
 B. TEMPERATURE RANGE: -65° C TO +165° C
4. PACKAGING:
 A. QUANTITY: SINGLE PACK
 B. MARKING: PACKAGING TO BE MARKED
 "AMPHENOL RF, PART NUMBER, AND DATE CODE"

5. ORDERING INFORMATION:
 A. ADDITIONAL CANDLESTICK LENGTHS ARE AVAILABLE
 B. CHANGE XXX TO DESIRED CONTACT PROJECTION AND
 YYY TO DESIRED INSULATOR PROJECTION LENGTH IN INCHES.
 [.705 MAX. CONTACT PROJECTION, .100 MIN. CONTACT PROJECTION]
 C. EXAMPLE: 901-IPB100000AE HAS CONTACT PROJECTION OF .100 [2.54]
 AND NO INSULATOR PROJECTION,
 AS SHOWN IN "VIEW A".
 901-IPB705590AM HAS CONTACT PROJECTION OF .705 [17.91] AND
 INSULATOR PROJECTION OF .590 [14.99],
 AS SHOWN IN "VIEW B".
 D. CONTACT AMPHENOL RF MARKETING FOR QUOTE AND MORE INFORMATION.

THIRD ANGLE PROJ.

REVISIONS

REV	DESCRIPTION	DATE	ECO	APPR
A	RELEASE TO MFG.	08-Aug-19	12523	CJV

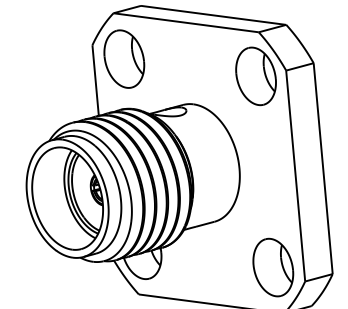

SCALE 3.000

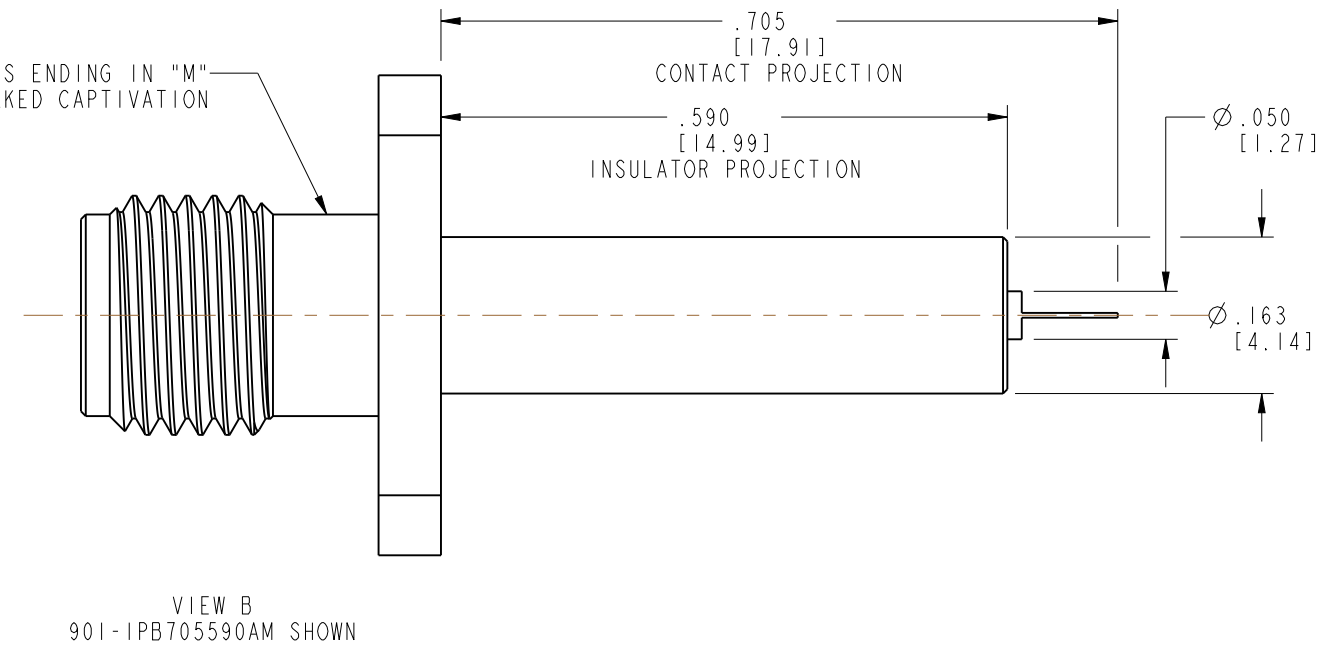
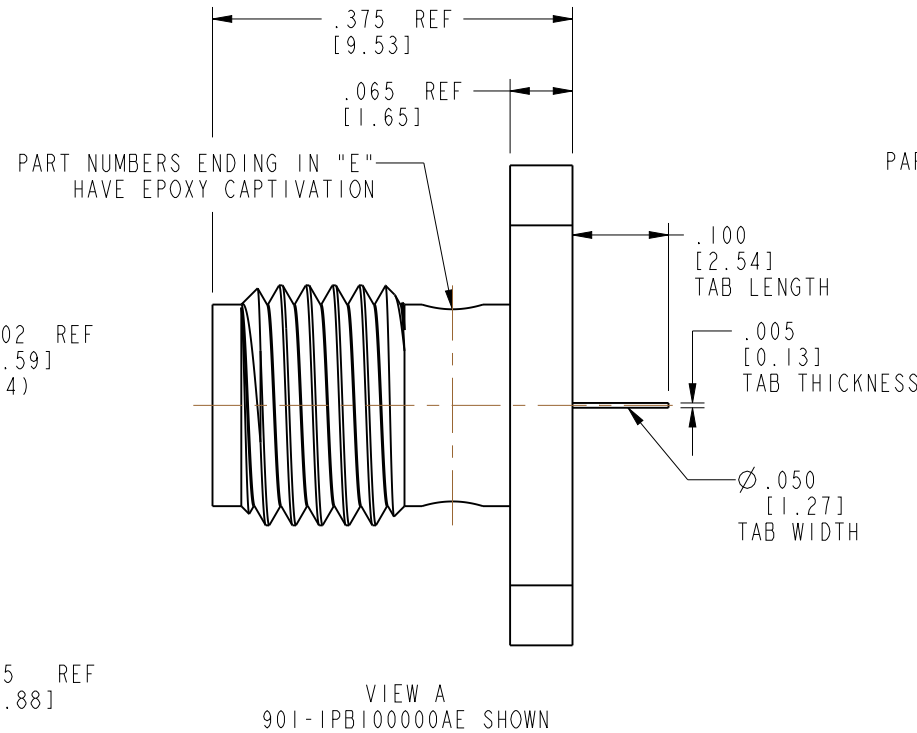
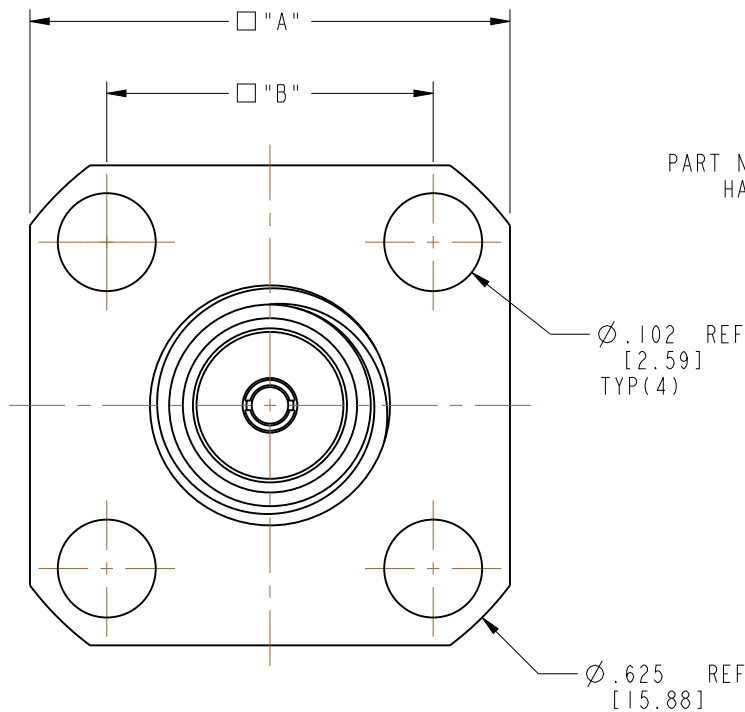

DRAWING NO.	"A" IN [MM]	"B" IN [MM]	CAPTIVATION
901-1PBXXXXYYAE	.375 [9.53]	.250 [6.35]	EPOXY
901-1PBXXXXYYAM	.375 [9.53]	.250 [6.35]	MECHANICAL
901-2PBXXXXYYAE	.500 [12.70]	.340 [8.64]	EPOXY
901-2PBXXXXYYAM	.500 [12.70]	.340 [8.64]	MECHANICAL
901-3PBXXXXYYAE	.687 [17.45]	.375 [9.53]	EPOXY
901-3PBXXXXYYAM	.687 [17.45]	.375 [9.53]	MECHANICAL
901-4PBXXXXYYAE	1.000 [25.40]	.689 [17.50]	EPOXY
901-4PBXXXXYYAM	1.000 [25.40]	.689 [17.50]	MECHANICAL

CUSTOMER OUTLINE DRAWING
 ALL OTHER SHEETS ARE FOR INTERNAL USE ONLY

UNLESS OTHERWISE SPECIFIED, DIMENSIONS ARE IN INCHES AND TOLERANCES ARE: 2 PLACE DECIMAL 3 PLACE DECIMAL ±.015 (0,381 mm) ±.005 (0,127 mm) ANGLES ± 1°	MATERIAL SEE NOTES	DRAWN B. GREENBAUM	DATE 26-Oct-17	TITLE SMA PANEL JACK, TAB CONTACT STEEL BODY PASSIVATED VARIOUS LENGTHS	Amphenol RF www.amphenolrf.com
		ENGINEER B. GREENBAUM	DATE 26-Oct-17		
NOTICE - These drawings, specifications, or other data (1) are, and remain the property of Amphenol corp. (2) must be returned upon request; and (3) are confidential and not to be disclosed to any person other than those to whom they are given by Amphenol Corp. the furnishing of these drawings, specifications, or other data by Amphenol Corp., or to any other person to anyone for any purpose is not to be regarded by implication or otherwise in any manner licensing, granting rights to permitting such holder or any other person to manufacture, use or sell any product, process or design, patented or otherwise, that may in any way be related to or disclosed by said drawings, specifications, or other data.	REFERENCE EAR: 7643 REF: 901-9215-3CCSF	APPROVED K. CAPOZZI	DATE 08-Aug-19	SCALE: 5.0:1.0 SHEET 2 OF 2	DRAWING NO. 901-XPBXXXXYYAX
	CONFIGURATION LEVEL: In Work	CAD FILE	DWG SIZE B	REV A	ITEM NO. 901-XPBXXXXYYAX
	FINISH				PART NO. 901-XPBXXXXYYAX