

Safety Light Curtain

F3SJ-E

EASY type reduces implementation costs with 1/2 the mounting time.

- In pursuit of simple functions: Upon detection of personnel, the machine stops.
- Can be used for simple hand intrusion detection.
- Implementation costs can be significantly reduced.



Ordering Information

Main Units

Safety Light Curtain

Application	Detection capability	Beam gap	Operating range	Protective height (mm)	Model	
					PNP output	NPN output
Hand protection	Dia. 25 mm	20 mm	0.2 to 7 m	185 to 1,105	F3SJ-E□□□□P25 *1	F3SJ-E□□□□N25

Note: F3SJ-E uses a 3 m prewired discrete cable.

*1. For S-mark compatible model, the suffix "-S" is added to the model name.
(Example) F3SJ-E0185P25-S

Safety Light Curtain Model List

Please contact our sales representative.

F3SJ-E Series (20 mm pitch)



Model		Number of beams	Protective height [mm] *2
PNP output *1	NPN output		
F3SJ-E0185P25	F3SJ-E0185N25	8	185
F3SJ-E0225P25	F3SJ-E0225N25	10	225
F3SJ-E0305P25	F3SJ-E0305N25	14	305
F3SJ-E0385P25	F3SJ-E0385N25	18	385
F3SJ-E0465P25	F3SJ-E0465N25	22	465
F3SJ-E0545P25	F3SJ-E0545N25	26	545
F3SJ-E0625P25	F3SJ-E0625N25	30	625
F3SJ-E0705P25	F3SJ-E0705N25	34	705
F3SJ-E0785P25	F3SJ-E0785N25	38	785
F3SJ-E0865P25	F3SJ-E0865N25	42	865
F3SJ-E0945P25	F3SJ-E0945N25	46	945
F3SJ-E1025P25	F3SJ-E1025N25	50	1,025
F3SJ-E1105P25	F3SJ-E1105N25	54	1,105

*1. For S-mark compatible model, the suffix "-S" is added to the model name.
(Example) F3SJ-E0185P25-S

*2. Protective height (mm) = Total sensor length

Accessories (Sold separately)

Relays with Forcibly Guided Contacts

Type	Appearance	Specifications	Model	Remarks
G7SA Relays with Forcibly Guided Contacts		<ul style="list-style-type: none"> Nodes: 4 Contact type: 2A2B Rated switch load: 250 VAC 6A, 30 VDC 6A 	G7SA-2A2B	For details on other models or socket models, refer to the OMRON's website.
		<ul style="list-style-type: none"> Nodes: 4 Contact type: 3NO+1NC Rated switch load: 250 VAC 6A, 30 VDC 6A 	G7SA-3A1B	
G7S-□-E Relays with Forcibly Guided Contacts		<ul style="list-style-type: none"> Nodes: 6 Contact type: 4NO+2NC Rated switch load: 250 VAC 10 A, 30 VDC 10 A 	G7S-4A2B-E	For details on other models or socket models, refer to the OMRON's website.
		<ul style="list-style-type: none"> Nodes: 6 Contact type: 3NO+3NC Rated switch load: 250 VAC 10 A, 30 VDC 10 A 	G7S-3A3B-E	

Laser Pointer

Appearance	Output	Model
	Laser Pointer for F3SJ	F39-PTJ

Spatter Protection Cover (2 covers per set, one for emitter and one for receiver) (10% Operating Range Attenuation)

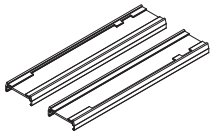
Appearance	Model
	F39-HB□□□□ *

* The same 4-digit numbers as the protective heights (□□□□ in the light curtain model names) are substituted by □ in the model names.

Protective Bar

Appearance	Model	Remarks
	F39-PB□□□□ *1	<ul style="list-style-type: none"> 2 Light Curtain brackets 4 mounting brackets 0 to 4 intermediate brackets for backside mounting (quantity required for the sensing width) 0 to 4 intermediate brackets for mounting to the sides (quantity required for the sensing width)
	F39-PB□□□□-S *1 *2	<ul style="list-style-type: none"> 1 Light Curtain bracket 2 mounting brackets 0 to 2 intermediate brackets for backside mounting (quantity required for the sensing width) 0 to 2 intermediate brackets for mounting to the sides (quantity required for the sensing width)

Note: The following are not provided with the Protective Bars.

- Safety Light Curtain
- Safety Light Curtain Top/Bottom Brackets
- Wall Mounting Screw Unit

*1. The same four digits indicating protective height that are used in the Sensor model number (□□□□) are used in the part of the Protector model number.

*2. Purchase the F39-PB□□□□ (which contains two sets of brackets) to use Protective Bars for both the Emitter and Receiver.







Test rod (Sold separately)

Diameter	Model
14mm dia.	F39-TRD14
20mm dia.	F39-TRD20
25mm dia.	F39-TRD25
30mm dia.	F39-TRD30

Mirrors (12% Operating Range Attenuation)

Appearance	Mirror material	Width (mm)	Thickness (mm)	Length L (mm)	Model	Remarks
	Glass mirror	145	32	445	F39-MLG0406	2 sets of cylinder mounting brackets and 4 screws are included.
				648	F39-MLG0610	
				749	F39-MLG0711	
				953	F39-MLG0914	
				1,105	F39-MLG1067	
				1,257	F39-MLG1219	
				1,499	F39-MLG1422	
				1,702	F39-MLG1626	
				1,905	F39-MLG1830	
				2,210	F39-MLG2134	

Sensor Mounting Bracket (Sold separately)

Appearance	Specifications	Model	Application	Remarks
	Top/bottom bracket	F39-LJB1	Top/bottom bracket for F3SJ-E/B	2 for an emitter, 2 for a receiver, total of 4 per set
	Intermediate bracket	F39-LJB2 *1 *2	In combination use with top/bottom bracket for F3SJ-E/B Can be used as free-location bracket.	1 set with 2 pieces
	One-touch bracket	F39-LJB3-M6 *1	One-touch bracket for F3SJ-E/B Supports M6 slide nut for aluminum frame.	1 set with 2 pieces
		F39-LJB3-M8 *2	One-touch bracket for F3SJ-E/B Supports M8 slide nut for aluminum frame.	
	One-touch M6 bracket One-touch M8 bracket	F39-LJB3-M6K *1	Bracket to mount an intermediate bracket to the aluminum frame with a single touch.	Hexagon socket head cap screws (M6 x 10) are included.
		F39-LJB3-M8K *2		Hexagon socket head cap screws (M8 x 14) are included.
	Compatible mounting bracket	F39-LJB4	Mounting bracket used when replacing existing area sensors (F3SJ-A or F3SN) with the F3SJ-E/B.	2 for an emitter, 2 for a receiver, total of 4 per set
	Contact mount bracket	F39-LJB5	Bracket to closely contact the back side of the Sensor.	2 for an emitter, 2 for a receiver, total of 4 per set

Note: All the sensor mounting brackets for F3SJ-E are sold separately.

*1. Combining F39-LJB2 and F39-LJB3-M6K makes F39-LJB3-M6.

*2. Combining F39-LJB2 and F39-LJB3-M8K makes F39-LJB3-M8.

Specifications (For details, refer to the instruction manual or User's manual.)

Main Units

F3SJ-E□□□□P25/N25

Model	PNP output	F3SJ-E□□□□P25
	NPN output	F3SJ-E□□□□N25
Sensor type	Type 4 safety light curtain	
Setting tool connection *1	Parameter settings: Not available	
Safety category	Safety purpose of category 4, 3, 2, 1, or B	
Detection capability	Opaque objects 25 mm in diameter	
Beam gap (P)	20 mm	
Number of beams (n)	8 to 54	
Protective height (PH)	185 to 1,105 mm	
Lens diameter	Diameter 5 mm	
Operating range *2	0.2 to 7 m	
Response time (under stable light incident condition)	ON to OFF	15 ms max.
	OFF to ON	70 ms max.
Startup waiting time	2 s max.	
Power supply voltage (Vs)	SELV/PELV 24 VDC±20% (ripple p-p 10% max.)	
Consumption current (no load)	PNP output	Emitter : Up to 22 beams: 41 mA max., 26 to 42 beams: 57 mA max., 46 to 54 beams: 63 mA max. Receiver : Up to 22 beams: 42 mA max., 26 to 42 beams: 47 mA max., 46 to 54 beams: 51 mA max.
	NPN output	Emitter : Up to 22 beams: 41 mA max., 26 to 42 beams: 57 mA max., 46 to 54 beams: 63 mA max. Receiver : Up to 22 beams: 40 mA max., 26 to 42 beams: 45 mA max., 46 to 54 beams: 48 mA max.
Light source (emitted wavelength)	Infrared LED (870 nm)	
Effective aperture angle (EAA)	Based on IEC 61496-2. Within ±2.5° for both emitter and receiver when the detection distance is 3 m or over	
Safety outputs (OSSD)	PNP output	Two PNP transistor outputs, load current 200 mA max., residual voltage 2 V max. (except for voltage drop due to cable extension), Leakage current 1 mA max., load inductance 2.2 H max. *3, Maximum capacity load 1 μF *4
	NPN output	Two NPN transistor outputs, load current 200 mA max., residual voltage 2 V max. (except for voltage drop due to cable extension), Leakage current 1 mA max., load inductance 2.2 H max. *3, Maximum capacity load 1 μF *4
Output operation mode	Safety output: On when receiving light	
Input voltage	PNP output	Test input: ON voltage: Vs-3 V to Vs (short circuit current: approx. 3.0 mA) *5 OFF voltage: 0 V to 1/2 Vs or open (short circuit current: approx. 4.0 mA) *5
	NPN output	Test input: ON voltage: 0 to 3 V (short circuit current: approx. 4.0 mA) OFF voltage: 1/2 Vs to Vs or open (short circuit current: approx. 3.0 mA) *5
Mutual interference prevention function	Mutual interference prevention algorithm prevents interference in up to 3 sets.	
Test function	<ul style="list-style-type: none"> • Self test (at power-ON and at power distribution) • External test (emission stop function by test input) 	
Protection circuit	Output short-circuit protection, and power supply reverse polarity protection	
Ambient temperature	Operating: -10 to 55°C (non-freezing), Storage: -25 to 70°C	
Ambient humidity	Operating: 35% to 85% (no condensation), Storage: 35% to 95% RH	
Operating ambient light intensity	Incandescent lamp: 3,000 lx max., Sunlight: 10,000 lx max.	
Insulation resistance	20 MΩ min. (at 500 VDC)	
Dielectric strength	1,000 VAC 50/60 Hz, 1 min	
Degree of protection	IP65 (IEC 60529)	
Vibration resistance	Malfunction: 10 to 55 Hz, Multiple amplitude of 0.7 mm, 20 sweeps in X, Y, and Z directions	
Shock resistance	Malfunction: 100 m/s ² , 1,000 times each in X, Y, and Z directions	
Pollution degree	Pollution degree 3 (IEC 60664-1)	
Power cable	Connection method: Pull-out type, cable length 3 m Number of wires: Emitter: 5 wires, receiver: 6 wires Cable diameter: Dia. 6 mm Allowable bending radius: R5 mm	
Extension cable	30 m max. *6	
Material	Case: Aluminum Cap: ABS resin, PBT Optical cover: PMMA resin (acrylic) Cable: Oil resistant PVC	
Net Weight *7	Weight (g) = (protective height) x 1.59 + 330	
Gross Weight *8	Weight (g) = (protective height) x 2.6 + 800	
Accessories	Instruction Manual, Quick Installation Manual (QIM) *9	
Applicable standards *10	IEC 61496-1, EN 61496-1, UL 61496-1, Type 4 ESPE (Electro-Sensitive Protective Equipment) IEC 61496-2, EN 61496-2, UL 61496-2, Type 4 AOPD (Active Opto-electronic Protective Devices) IEC 61508-1 to -3, EN 61508-1 to -3 SIL3 ISO 13849-1: 2015, EN ISO 13849-1: 2015 (PLe/Safety Category 4) UL 508, UL 1998, CAN/CSA C22.2 No.14, CAN/CSA C22.2 No.0.8	

*1. Do not use the Support Software and Setting Console for F3SJ-A. Operation cannot be guaranteed.

*2. Use of the Spatter Protection Cover causes a 10% maximum sensing distance attenuation.

*3. The load inductance is the maximum value when the safety output frequently repeats ON and OFF. When you use the safety output at 4 Hz or less, the usable load inductance becomes larger.

*4. These values must be taken into consideration when connecting elements including a capacitive load such as capacitor.

*5. The Vs indicates a voltage value in your environment.

*6. To extend a cable of the F3SJ-E, refer to the User's Manual (SCHG-733/732).

*7. The net weight is the weight of an emitter and a receiver.

*8. The gross weight is the weight of an emitter, a receiver, included accessories and a package.

*9. Mounting brackets and test rod are sold separately.

*10. Refer to Safety Precautions for information about Legislation and Standards.

Indicator

Emitter

Name of indicator	Label	ON	Blinking
Top-beam-state indicator	TOP	Turns ON when the top beam is receiving light.	---
Stable-state indicator	STB	Turns ON when incidence level is more than 170% of the output ON threshold.	Blinks when the safety output is turned OFF due to disturbance light or vibration.
ON/OFF-state indicator	ON OFF	Green: Turns ON when safety output is ON. Red: Turns OFF when safety output is OFF.	Red: Blinks when the F3SJ-E enters a lockout due to a safety output error.
Lockout indicator	LOCKOUT	Turns ON when the F3SJ-E enters a lockout on the receiver.	Blinks when the F3SJ-E enters a lockout on the emitter.
Power indicator	POWER	Turns ON while the power of the emitter is ON.	Blinks when the F3SJ-E enters a lockout due to power voltage/noise.
Test indicator	TEST	---	Blinks when external test is being performed.
Bottom-beam-state indicator	BTM	Turns ON when the bottom beam is receiving light.	---

Receiver

Name of indicator	Label	ON	Blinking
Top-beam-state indicator	TOP	Turns ON when the top beam is receiving light.	---
Stable-state indicator	STB	Turns ON when incidence level is more than 170% of the output ON threshold.	Blinks when the safety output is turned OFF due to disturbance light or vibration.
ON/OFF-state indicator	ON OFF	Green: Turns ON when safety output is ON. Red: Turns OFF when safety output is OFF.	Red: Blinks when the F3SJ-E enters a lockout due to a safety output error.
Lockout indicator	LOCKOUT	Turns ON when the F3SJ-E enters a lockout on the emitter.	Blinks when the F3SJ-E enters a lockout on the receiver.
Communication indicator	COM	Turns ON when communication between emitter and receiver is established.	Blinks when the F3SJ-E enters lockout due to a communication error between receiver and emitter.
Configuration indicator	CFG	---	Blinks when the F3SJ-E enters lockout due to a model type error between receiver and emitter.
Internal error indicator	INTERNAL	---	Blinks when the F3SJ-E enters a lockout due to an internal error.
Bottom-beam-state indicator	BTM	Turns ON when the bottom beam is receiving light.	---

Accessories

Laser Pointer

Item	Model	F39-PTJ
Applicable sensor	F3SJ Series	
Power supply voltage	4.65 or 4.5 VDC	
Battery	Three button batteries (SR44 or LR44)	
Battery life *	SR44: 10 hours of continuous operation, LR44: 6 hours of continuous operation	
Light source	Red semiconductor laser (wavelength: 650 nm, 1 mW max. JIS class 2, EN/IEC class 2, FDA class II)	
Spot diameter (typical value)	6.5 mm at 10 m	
Ambient temperature	Operating: 0 to 40°C Storage: -15 to 60°C (with no icing or condensation)	
Ambient humidity	Operating and storage: 35% to 85% (with no condensation)	
Material	Laser module case: aluminum Mounting bracket: aluminum and stainless	
Weight	Approx. 220 g (packed)	
Accessories	Laser safety standard labels (EN: 1, FDA: 3) Button batteries (SR44: 3), instruction manual	

* Battery life varies depending on a battery used.

Connections

Basic Wiring Diagram

Minimum wiring required to check the operation of the F3SJ-E [PNP Output]

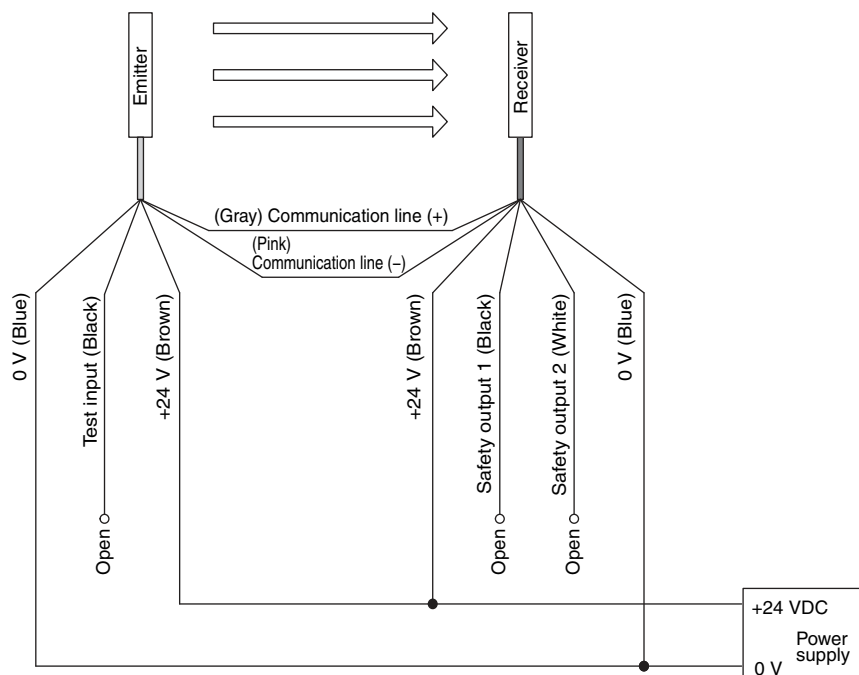

Note: This circuit diagram is used for operation check. For an actual circuit example, refer to page 8.

Minimum wiring required to check the operation of the F3SJ-E [NPN Output]

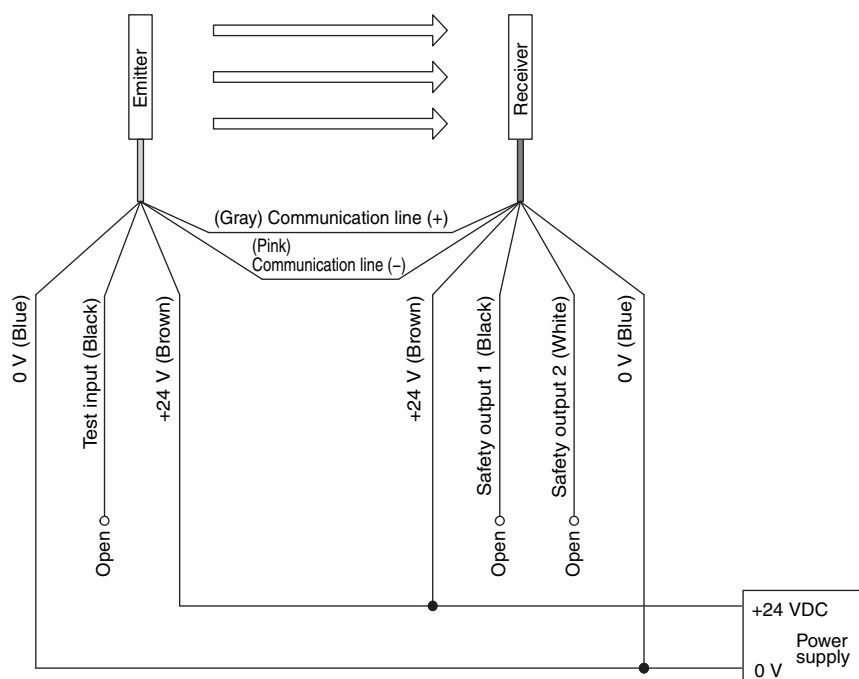

Note: This circuit diagram is used for operation check. For an actual circuit example, refer to page 8.

Input/Output Circuit Diagram

[PNP Output]

Entire Circuit Diagram

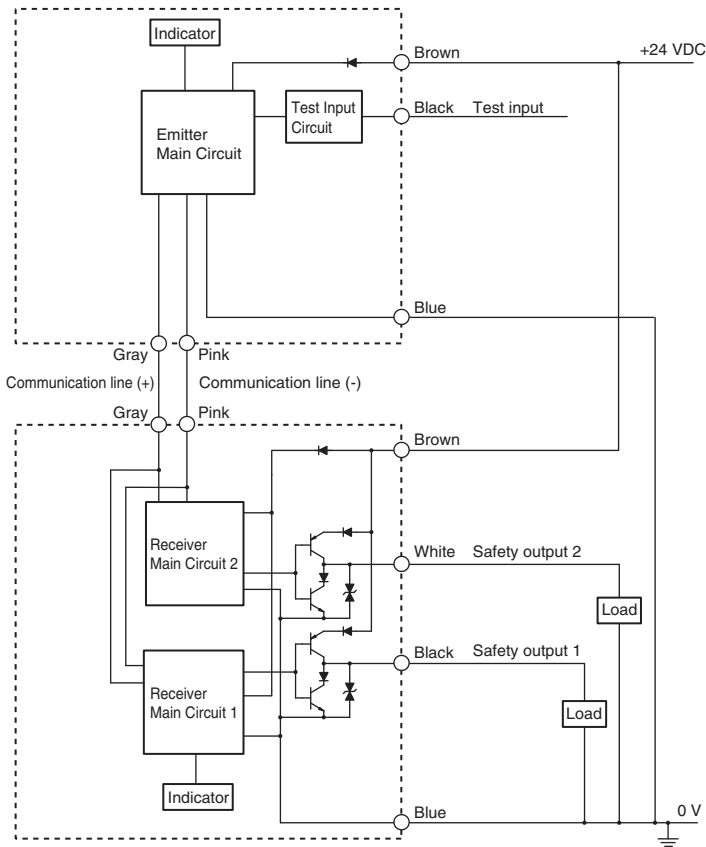

Input circuit diagram by function

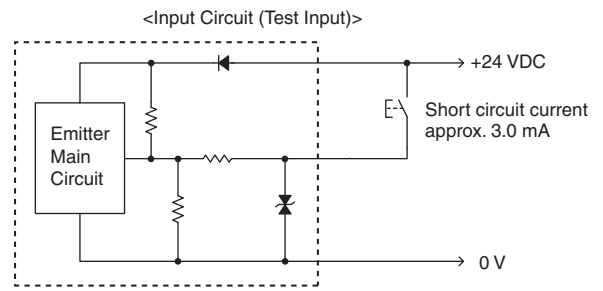

[NPN Output]

Entire Circuit Diagram

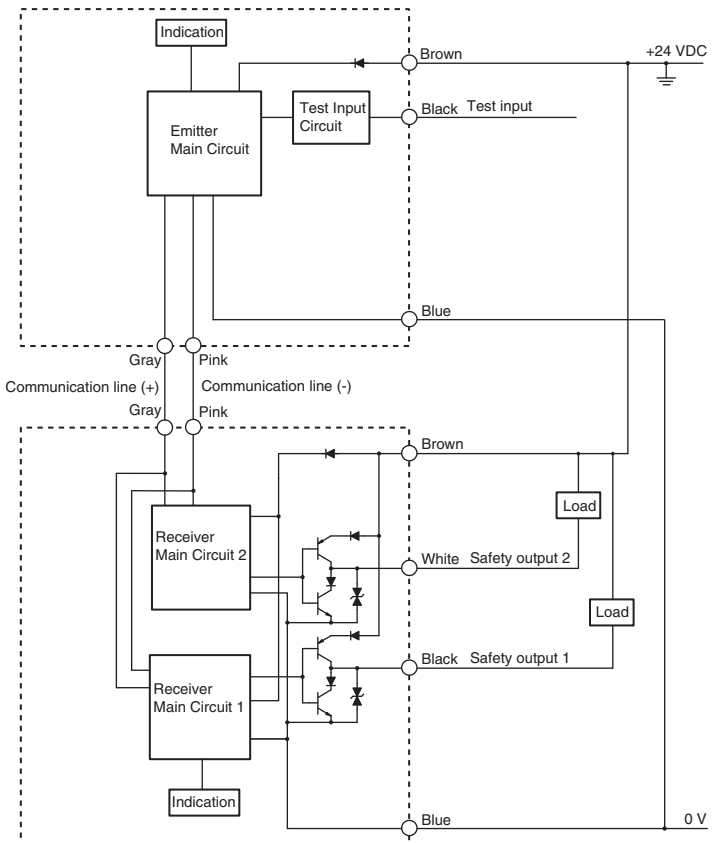

Input circuit diagram by function

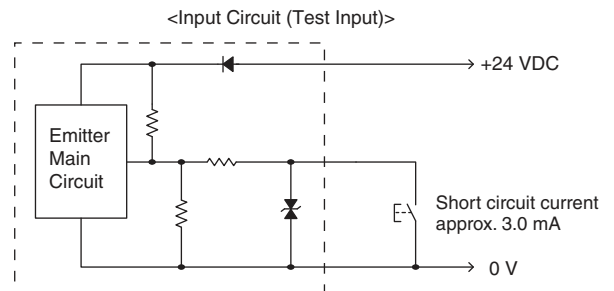

Connection Circuit Examples

Wiring for single F3SJ-E application [PNP Output]

Highest achievable PL/ safety category	Model	Stop category	Reset
PLe/4 equivalent	Safety Light Curtain F3SJ-E□□□□P25 Safety Relay G7SA	0	Manual

Note: The above PL is only the evaluation result of the example. The PL must be evaluated in an actual application by the customer after confirming the usage conditions.

● Application Overview

- The power supply to the motor M is turned OFF when the beam is blocked.
- The power supply to the motor M is kept OFF until the beams are unblocked and the reset switch S2 is pressed.

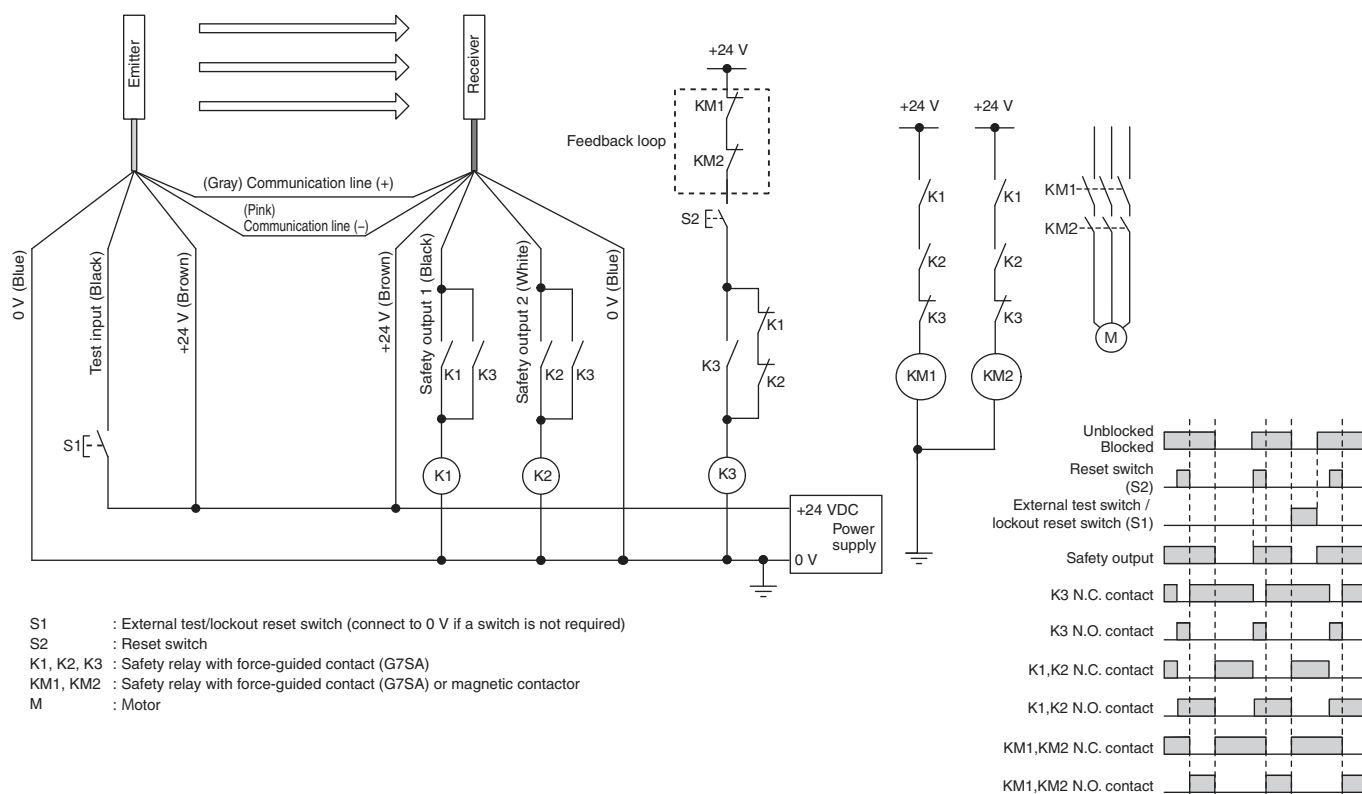

Wiring for single F3SJ-E application [NPN Output]

Highest achievable PL/ safety category	Model	Stop category	Reset
PLe/4 equivalent	Safety Light Curtain F3SJ-E□□□□N25 Safety Relay G7SA	0	Manual

Note: The above PL is only the evaluation result of the example. The PL must be evaluated in an actual application by the customer after confirming the usage conditions.

● Application Overview

- The power supply to the motor M is turned OFF when the beam is blocked.
- The power supply to the motor M is kept OFF until the beams are unblocked and the reset switch S2 is pressed.

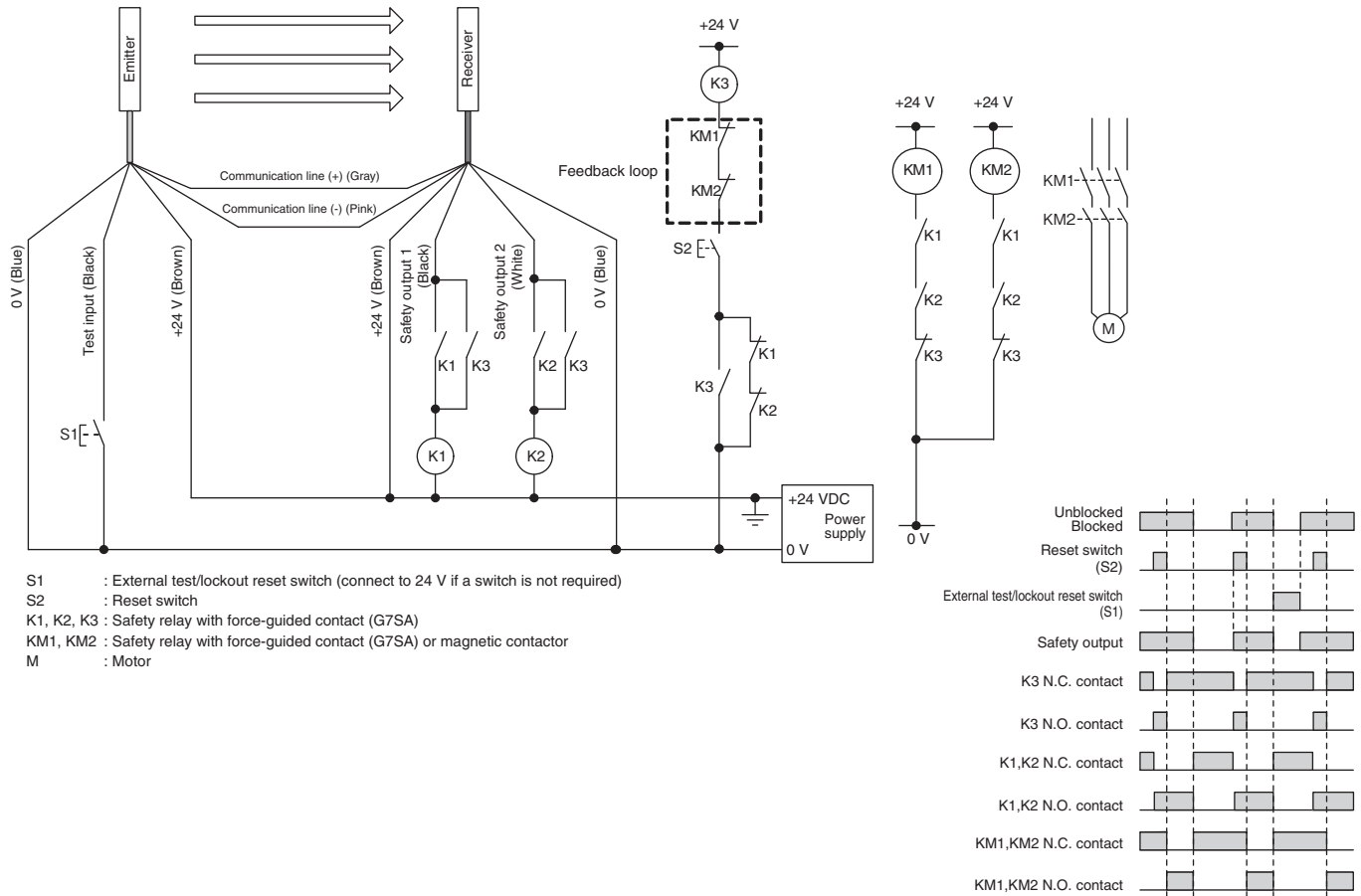

Wiring to connect a F3SJ-E with a controller G9SP [PNP Output]

Highest achievable PL/safety category	Model	Stop category	Reset
PLe/4 equivalent	Safety Light Curtain F3SJ-E□□□□P25 Safety Controller G9SP Safety Relay G7SA Emergency Stop Switch A165E/A22E	0	Manual

Note: The above PL is only the evaluation result of the example. The PL must be evaluated in an actual application by the customer after confirming the usage conditions.

● Application Overview

- The power supply to the motor M is turned OFF when the beam is blocked.
- The power supply to the motor M is turned OFF when the emergency stop switch is pressed.
- The power supply to the motor M is kept OFF until the beams are unblocked and the reset switch S2 is pressed while the emergency stop switch is released.

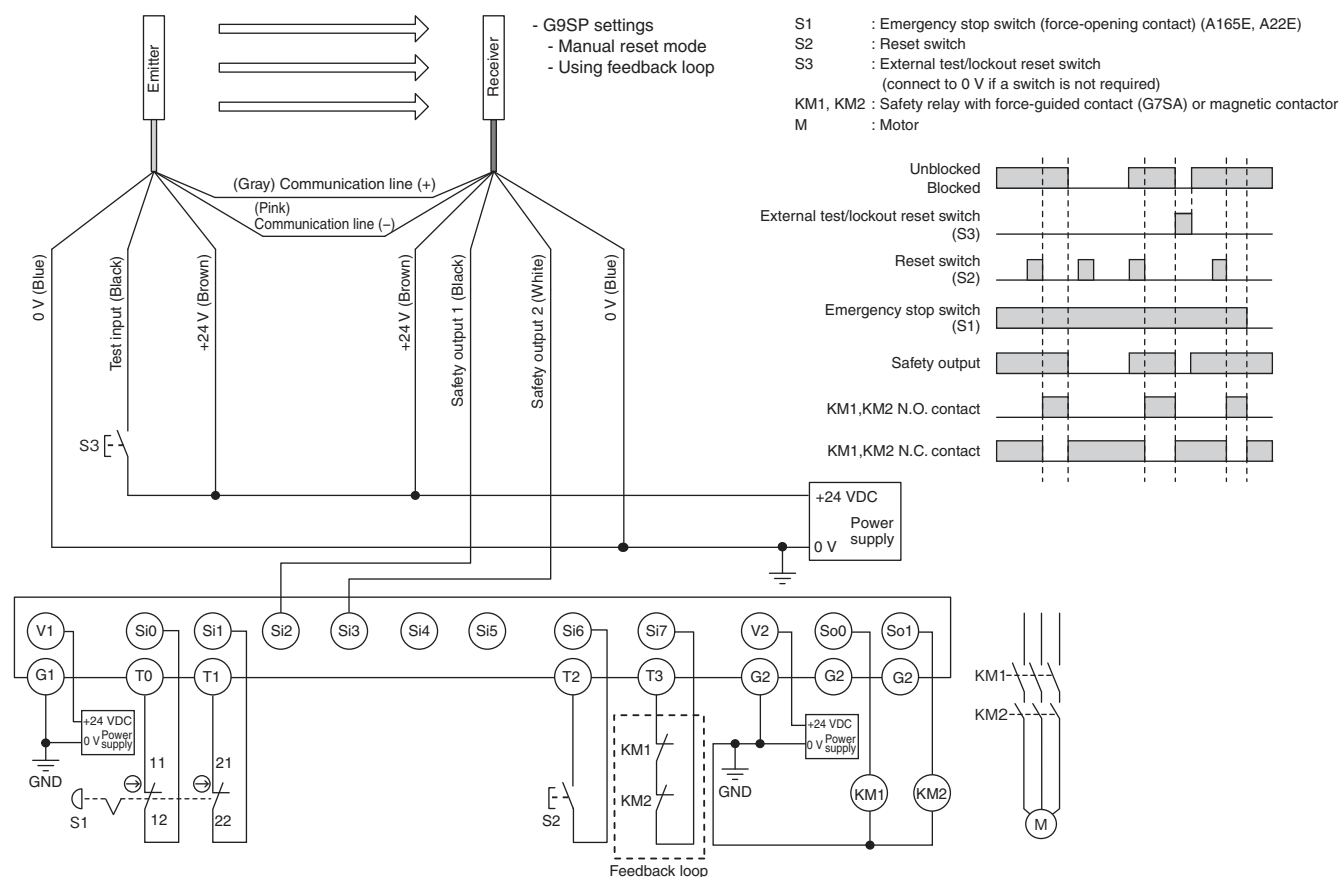

Wiring to connect a F3SJ-E with a controller G9SA-301 [PNP Output]

Highest achievable PL/ safety category	Model	Stop category	Reset
PLe/4 equivalent	Safety Light Curtain F3SJ-E□□□□P25 Safety Relay Unit G9SA-301 24V AC/DC Safety Relay G7SA Emergency Stop Switch A165E/A22E	0	Manual

Note: The above PL is only the evaluation result of the example. The PL must be evaluated in an actual application by the customer after confirming the usage conditions.

● Application Overview

- The power supply to the motor M is turned OFF when the beam is blocked.
- The power supply to the motor M is turned OFF when the emergency stop switch is pressed.
- The power supply to the motor M is kept OFF until the beams are unblocked and the reset switch S2 is pressed while the emergency stop switch is released.

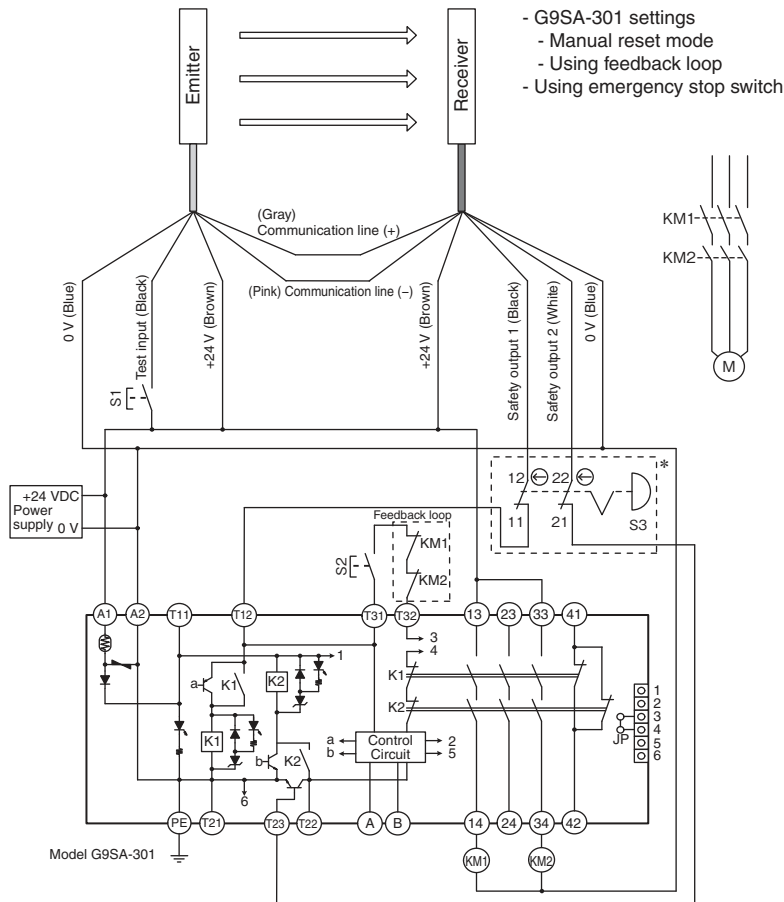

Wiring for auto reset mode

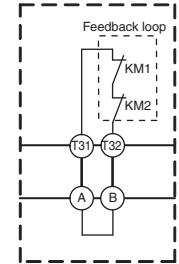

* If an emergency stop switch is not used, connect safety output 1 to T12 terminal and safety output 2 to T23 directly.

- S1: External test/lockout reset switch (connect to 0 V if a switch is not required)
- S2: Interlock reset switch
- S3: Emergency stop switch (force-opening contact) (A165E, A22E)
- KM1, KM2: Safety relay with force-guided contact (G7SA) or magnetic contactor
- M: Motor

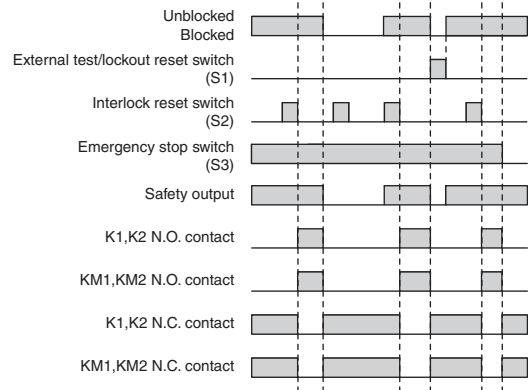

Wiring to connect a F3SJ-E with a controller G9SA-301-P [NPN Output]

Highest achievable PL/ safety category	Model	Stop category	Reset
PLe/4 equivalent	Safety Light Curtain F3SJ-E□□□□N25 Safety Relay Unit G9SA-301-P 24V DC Safety Relay G7SA Emergency Stop Switch A165E/A22E	0	Manual

Note: The above PL is only the evaluation result of the example. The PL must be evaluated in an actual application by the customer after confirming the usage conditions.

● Application Overview

- The power supply to the motor M is turned OFF when the beam is blocked.
- The power supply to the motor M is turned OFF when the emergency stop switch is pressed.
- The power supply to the motor M is kept OFF until the beams are unblocked and the reset switch S2 is pressed while the emergency stop switch is released.

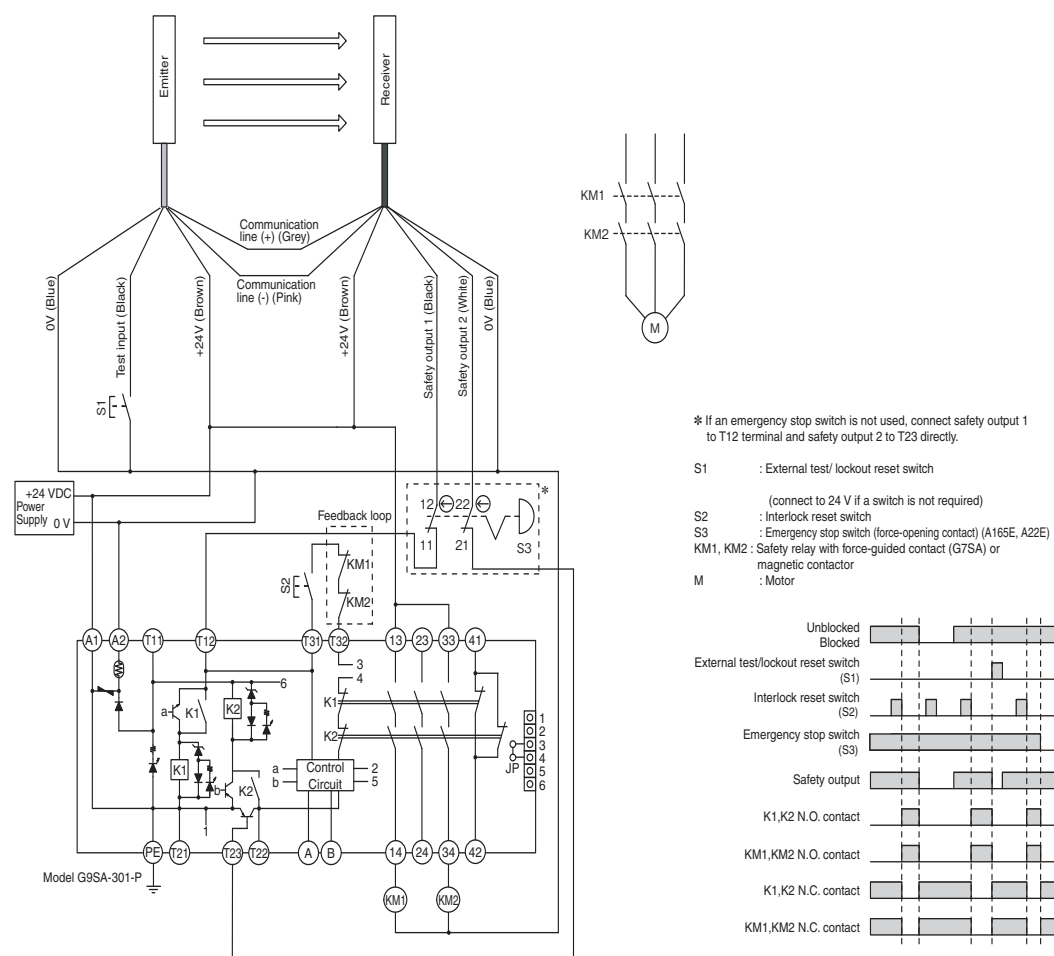

- Note:**
1. As the G9SP Safety Controller is a PNP output type, it cannot be connected to the F3SJ-E□□□□N25. Also, a Safety Controller with PNP output cannot be connected to the F3SJ-E□□□□N25.
 2. The G9SA-301-P is a safety relay unit only for NPN output.

F3SJ-E/F3SJ-B

Dimensions

(Unit: mm)

The dimensions of the F3SJ-E and F3SJ-B are the same except for connector cables and cable leads.

Main Units

Mounting Top/Bottom and Intermediate Brackets

Backside mounting

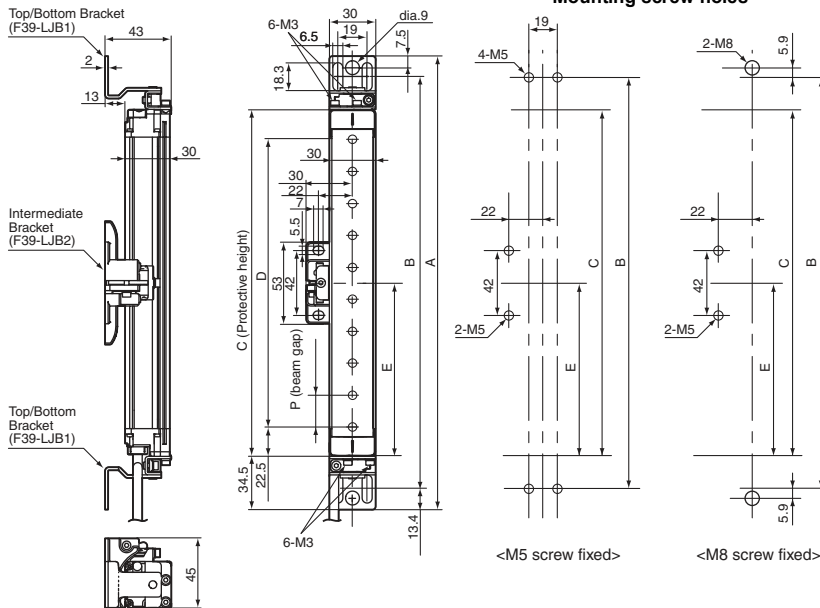

C (protective height): 4-digit number in the table
 $A = C + 69$, $B = C + 42.2$
 $D = C - 45$, $E =$ See table below, $P = 20$

Protective height	Number of intermediate brackets	E
185 to 1,105	0	---
1,185 to 1,345	1	C/2 max.
1,425 to 2,065	2	C/3 max.

Side mounting

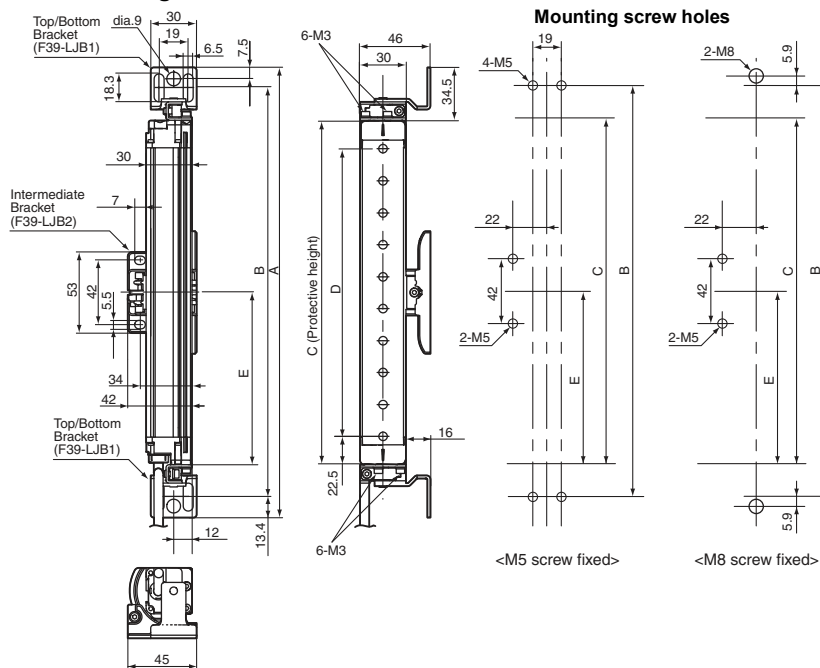

C (protective height): 4-digit number in the table
 $A = C + 69$, $B = C + 42.2$
 $D = C - 45$, $E =$ See table below, $P = 20$

Protective height	Number of intermediate brackets	E
185 to 1,105	0	---
1,185 to 1,345	1	C/2 max.
1,425 to 2,065	2	C/3 max.

Dimensions of top/bottom bracket for F39-LJB1

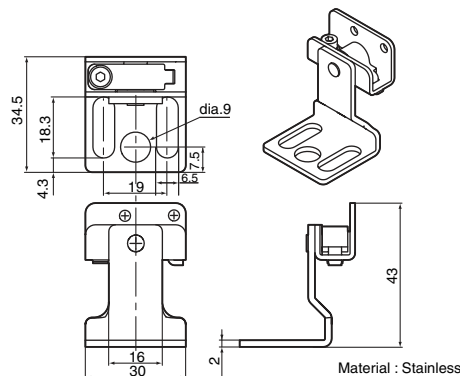

Mounting Intermediate Brackets only (location-free mounting)

Backside mounting

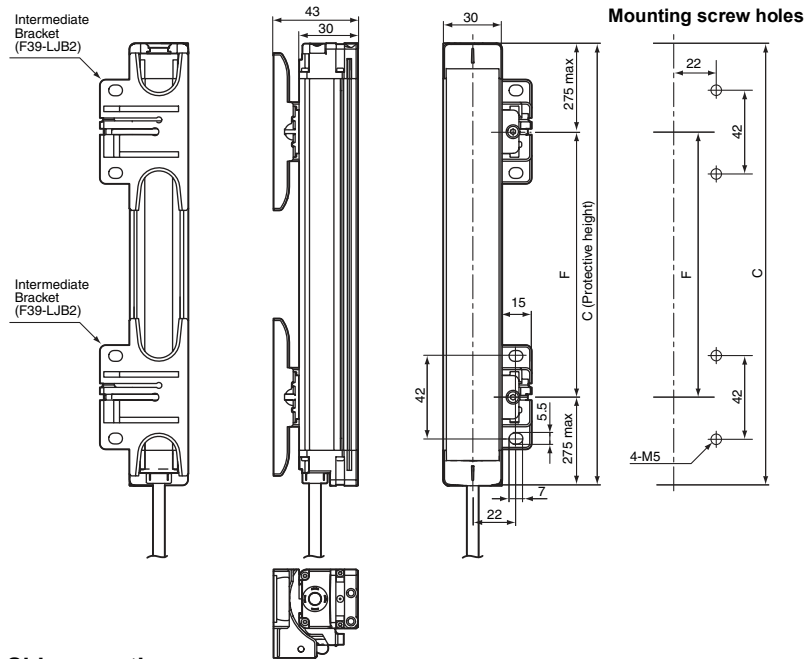

C (protective height): 4-digit number in the table
F = See the table below.

Protective height	Number of intermediate brackets	F
185 to 225	1	---
305 to 1,105	2	555 mm max.
1,185 to 1,585	3	555 mm max.
1,665 to 2,065	4	555 mm max.

Side mounting

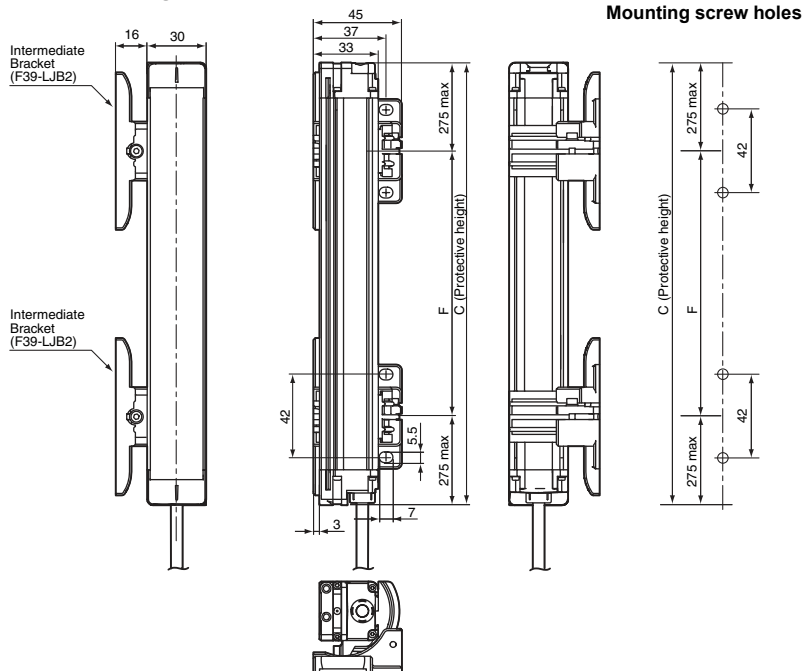

C (protective height): 4-digit number in the table
F = See the table below.

Protective height	Number of intermediate brackets	F
185 to 225	1	---
305 to 1,105	2	555 mm max.
1,185 to 1,585	3	555 mm max.
1,665 to 2,065	4	555 mm max.

Dimensions of intermediate bracket for F39-LJB2

Backside mounting

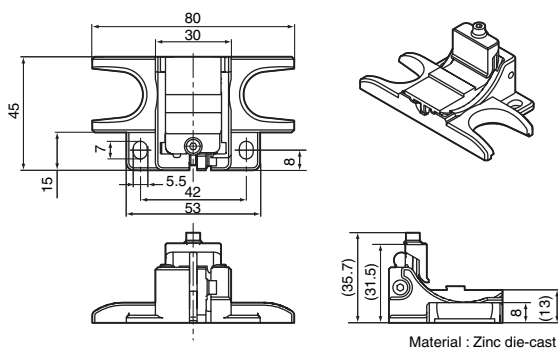

Side mounting

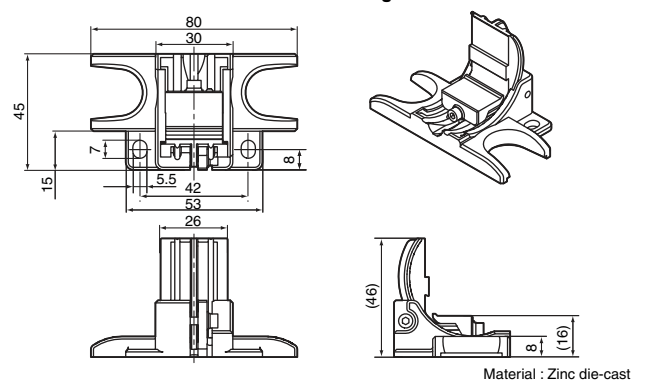

When Using One-touch Brackets

Backside mounting

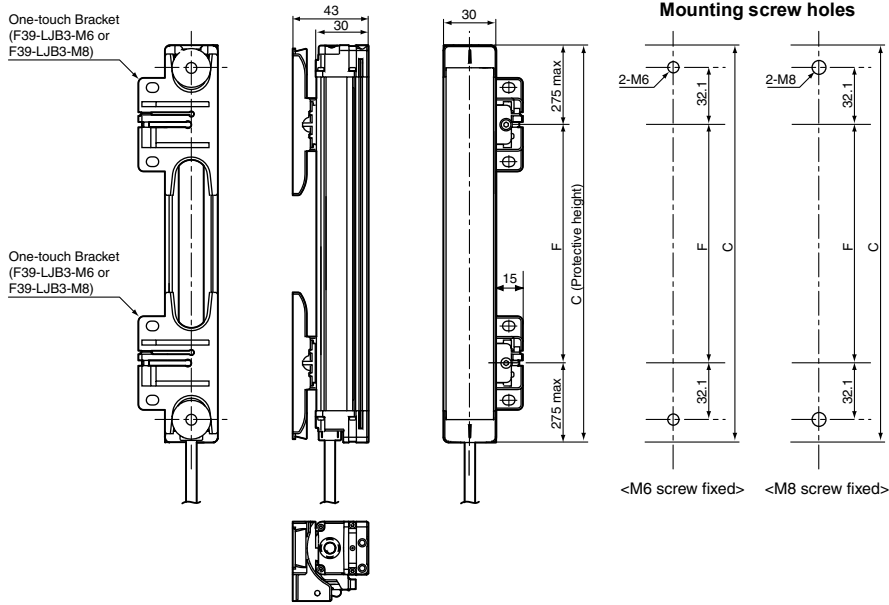

C (protective height): 4-digit number in the table
F = See the table below.

Protective height	Number of intermediate brackets	F
185 to 1,105	2	555 mm max.
1,185 to 1,585	3	555 mm max.
1,665 to 2,065	4	555 mm max.

Side mounting

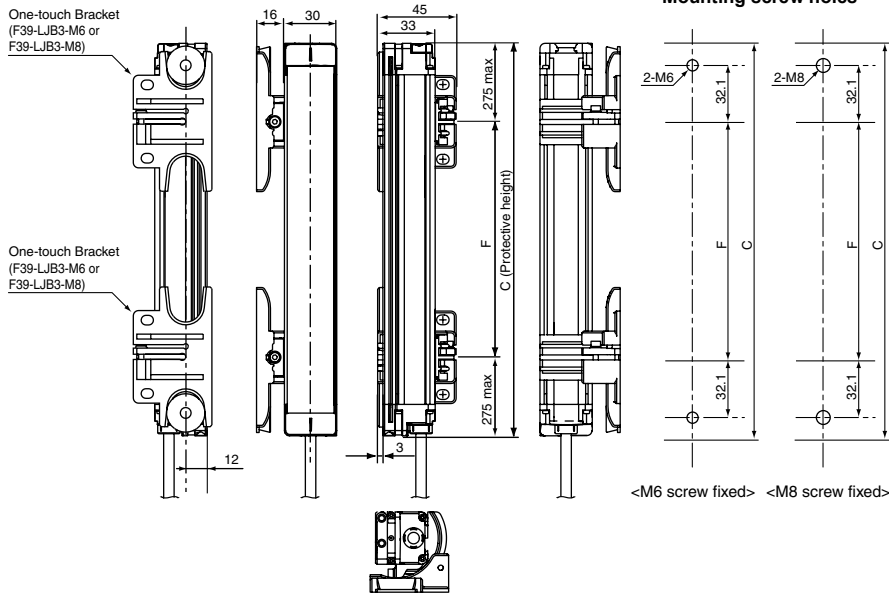

C (protective height): 4-digit number in the table
F = See the table below.

Protective height	Number of intermediate brackets	F
185 to 1,105	2	555 mm max.
1,185 to 1,585	3	555 mm max.
1,665 to 2,065	4	555 mm max.

Dimensions of one-touch bracket for F39-LJB3

Backside mounting

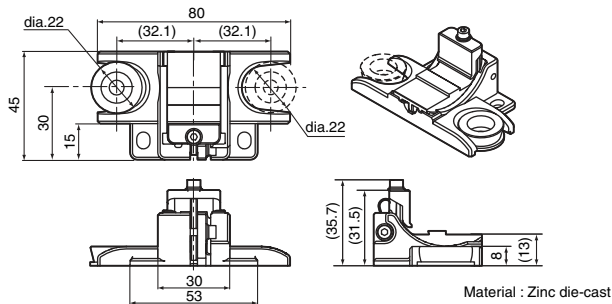

Side mounting

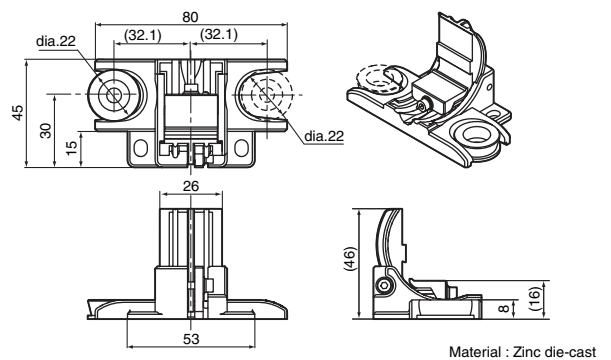

Dimensions of one-touch M6 bracket

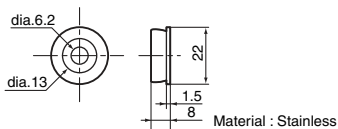

Dimensions of one-touch M8 bracket

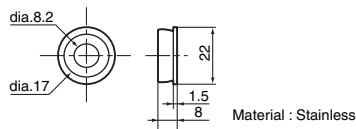

Precautions on mounting the sensor using One-touch Brackets

When using two One-touch Brackets to mount a sensor, the combination of One-touch M6 Bracket (or One-touch M8 Bracket) and Intermediate Bracket at the both ends of the sensor must be positioned opposite each other. When using three or more Brackets, One-touch M6 Brackets (or One-touch M8 Brackets) and Intermediate Brackets at other positions than the both ends must be in the same orientation.

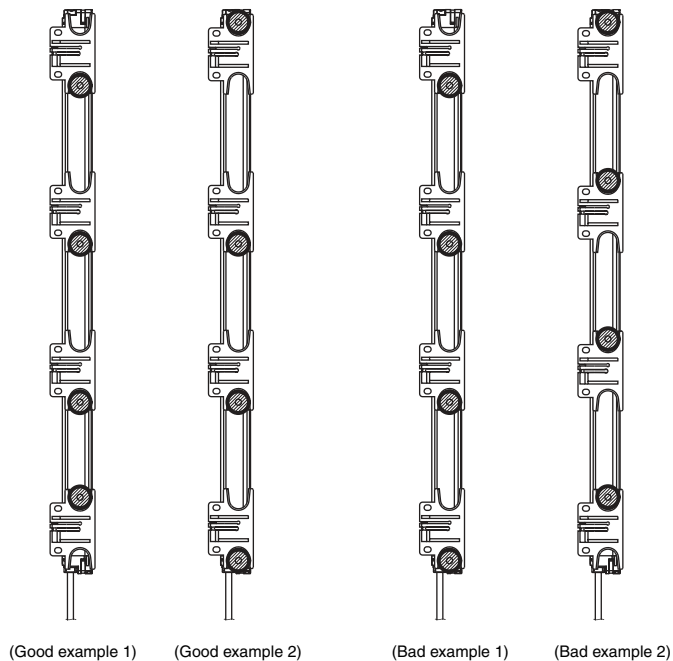

Mount One-touch M6 Brackets (or One-touch M8 Brackets) according to the mounting positions of the emitter and receiver. The positions of Intermediate Brackets mounted to the emitter and receiver must be aligned with each other.

Side view of the aluminum profile to be mounted

Position of the brackets to be mounted to the sensor

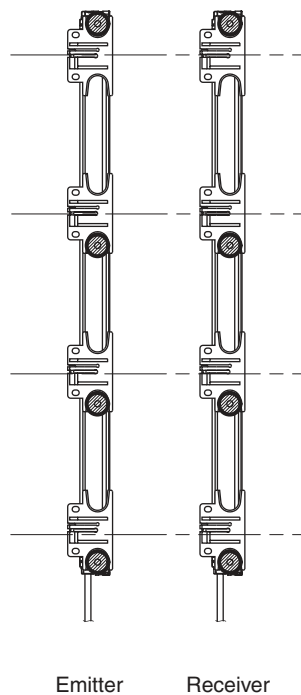
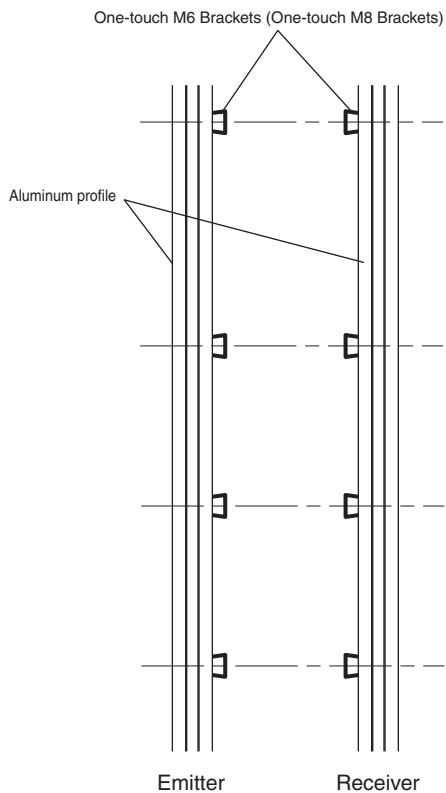

When Using Compatible Brackets

Backside mounting

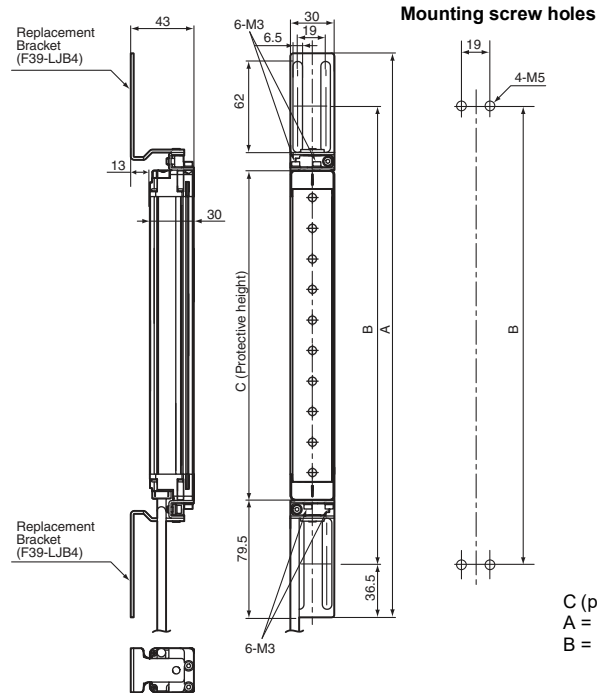

Side mounting

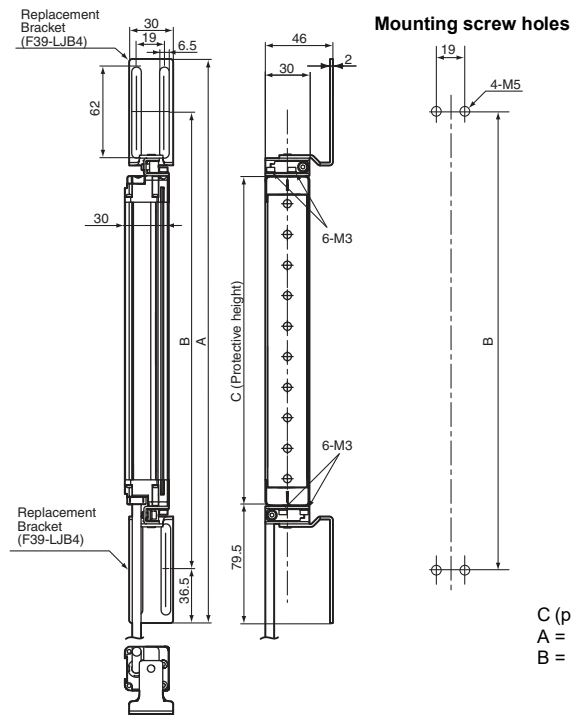

Dimensions of compatible bracket for F39-LJB4

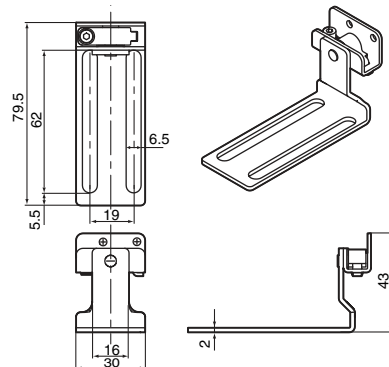

Material: Stainless

When Using Contact Mount Brackets

Backside mounting

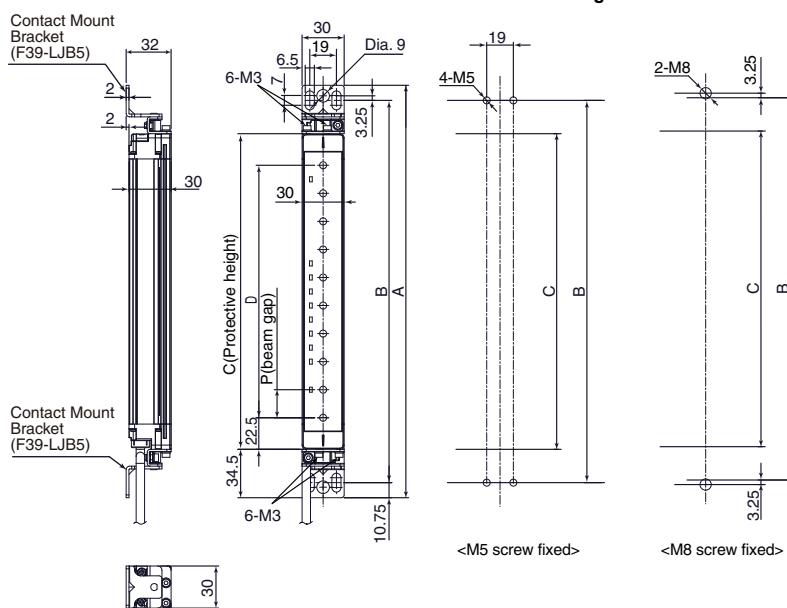

Side mounting

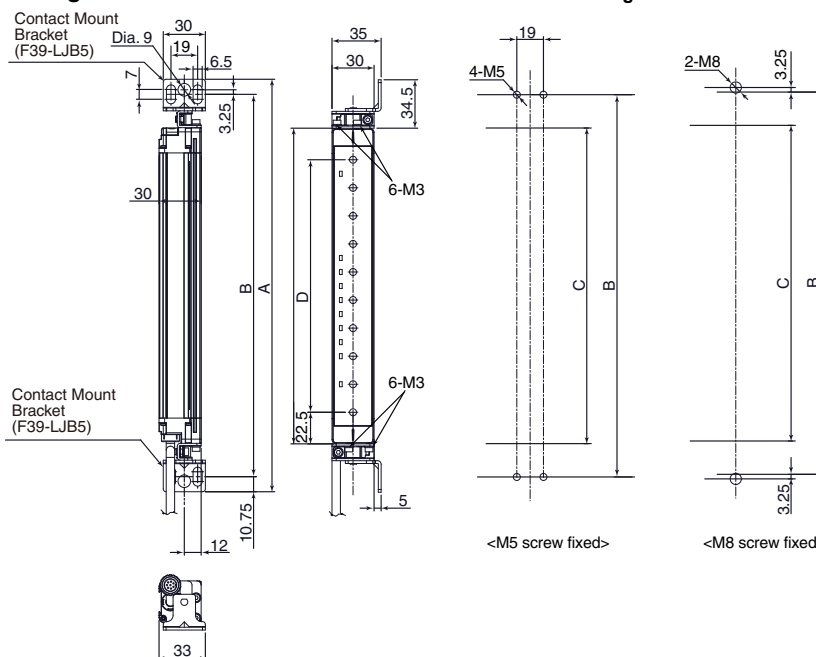

Dimensions of F39-LJB5 contact mount bracket

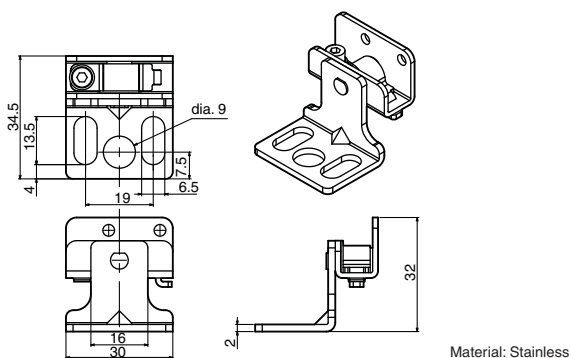

- Note:**
1. The protective height of the F3SJ-E/B series that supports the contact mount bracket is limited.
Protective height allowed for mounting: 185 mm to 1,105 mm (225 mm to 545 mm for the model with the suffix "-02TS")
 2. Brackets of other models such as F39-LJB1 cannot be used simultaneously.

F3SJ-B□□□□P25-02TS

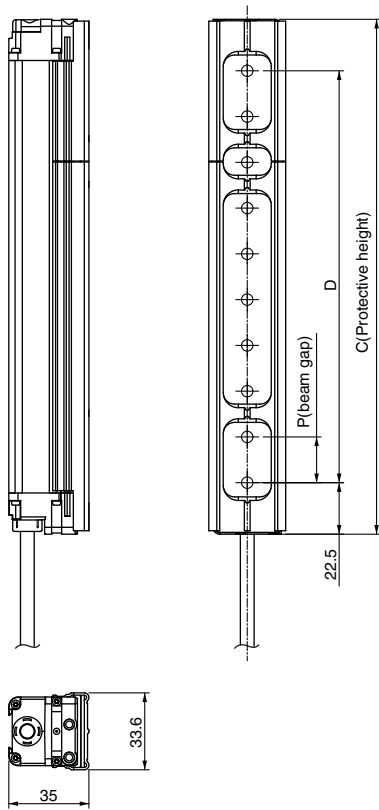

Note: For information on dimensions with brackets mounted, refer to the User's Manual of the F3SJ-B□□□□P25-02TS (SCHG-736). Brackets used are common to other F3SJ-E/B series.

Required number of intermediate brackets

The number of the brackets needed for the F3SJ-B□□□□P25-02TS differs from the other F3SJ-E/B series. The table below shows the number of brackets corresponding to the protective heights.

When using top/bottom bracket/compatible bracket + intermediate bracket

Protective height	Number of top/bottom brackets /compatible brackets	Number of intermediate brackets
0225 to 0545	2	0
0625 to 1105	2	1
1185 to 1585	2	2
1665 to 1985	2	3

Using only the intermediate bracket (free-location mounting)

Protective height	Number of intermediate brackets
0225 to 0385	2
0465 to 0785	3
0865 to 1105	4
1185 to 1425	5
1505 to 1825	6
1905 to 1985	7

When using the one-touch bracket

Protective height	Number of one-touch bracket
0225 to 0385	2
0465 to 0785	3
0865 to 1105	4
1185 to 1425	5
1505 to 1825	6
1905 to 1985	7

Accessories

Single-Ended Cable F3SJ-B

- F39-JD3A (L = 3 m)
- F39-JD7A (L = 7 m)
- F39-JD10A (L = 10 m)
- F39-JD15A (L = 15 m)
- F39-JD20A (L = 20 m)

Cable color: Gray for emitter and Black for receiver

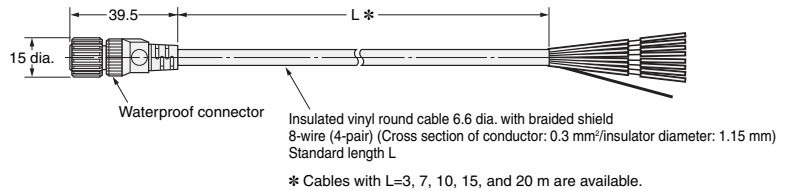

Double-Ended Cable F3SJ-B

- F39-JDR5B (L = 0.5 m)
- F39-JD1B (L = 1 m)
- F39-JD3 (L = 3 m)
- F39-JD5 (L = 5 m)
- F39-JD7B (L = 7 m)
- F39-JD10B (L = 10 m)
- F39-JD15B (L = 15 m)
- F39-JD20B (L = 20 m)

Cable color: Gray for emitter and Black for receiver

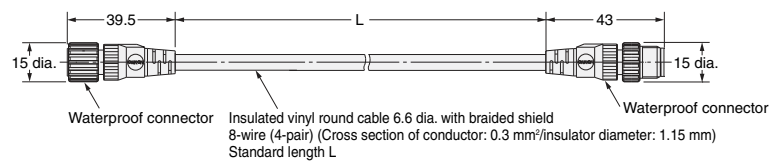

Simple Wiring Connector

F39-CN5

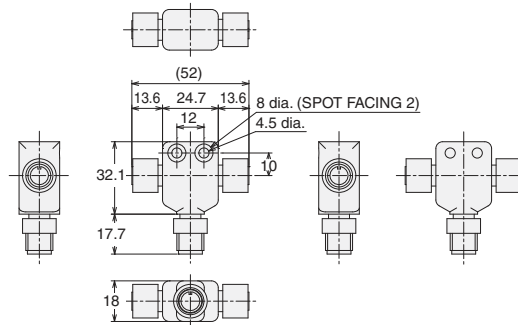

Control Unit

F3SJ-B

F3SP-B1P

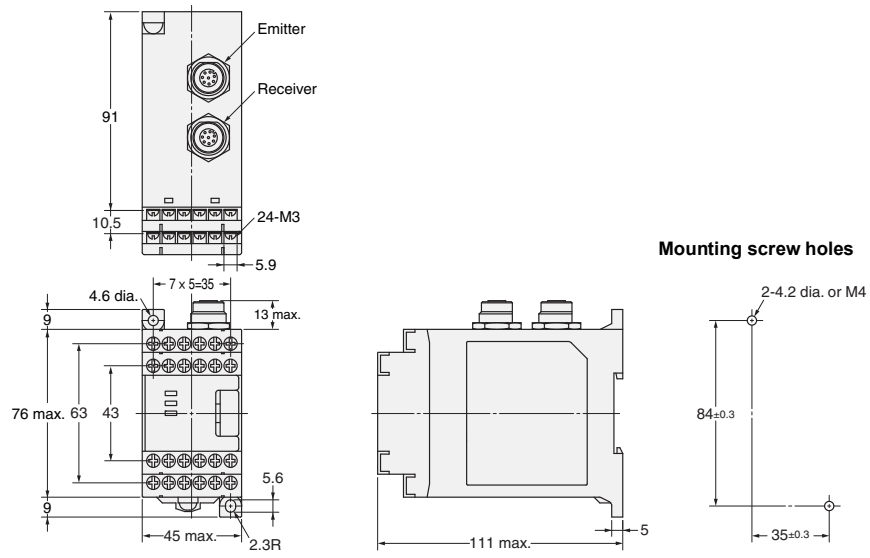

Laser Pointer

F3SJ-E F3SJ-B

F39-PTJ

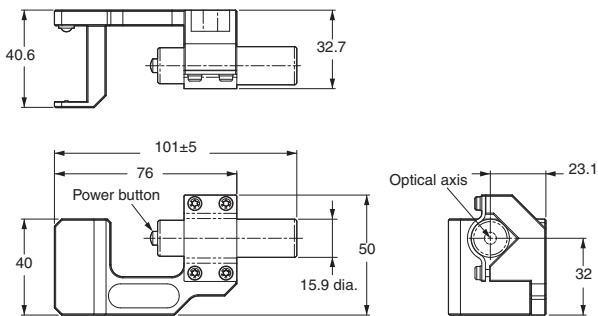

Spatter Protection Cover

F3SJ-E F3SJ-B

F39-HB□□□□

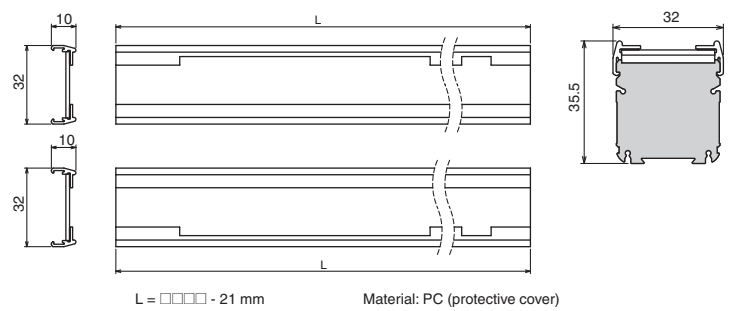

Mirrors

F39-MLG□

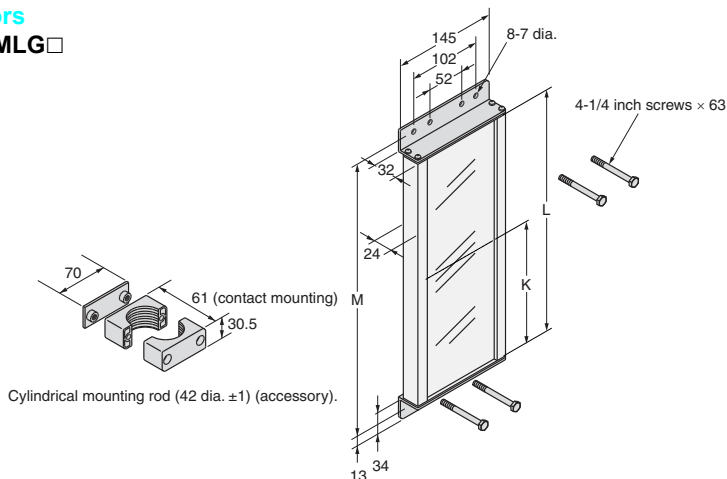

Model	L (mm)	M (mm)	K (mm)
F39-MLG0406	445	487	---
F39-MLG0610	648	690	---
F39-MLG0711	749	792	---
F39-MLG0914	953	995	---
F39-MLG1067	1,105	1,148	---
F39-MLG1219	1,257	1,300	---
F39-MLG1422 *	1,499	1,541	749
F39-MLG1626 *	1,702	1,744	851
F39-MLG1830 *	1,905	1,948	952
F39-MLG2134 *	2,210	2,252	1,054

* Following May 2018 production, products will include a two-piece mirror. "K" indicates the distance to the mirror seam.

F3SJ-E/F3SJ-B

Protective Bar F3SJ-E F3SJ-B

F39-PB□□□□

Backside mounting (using M5 screws)

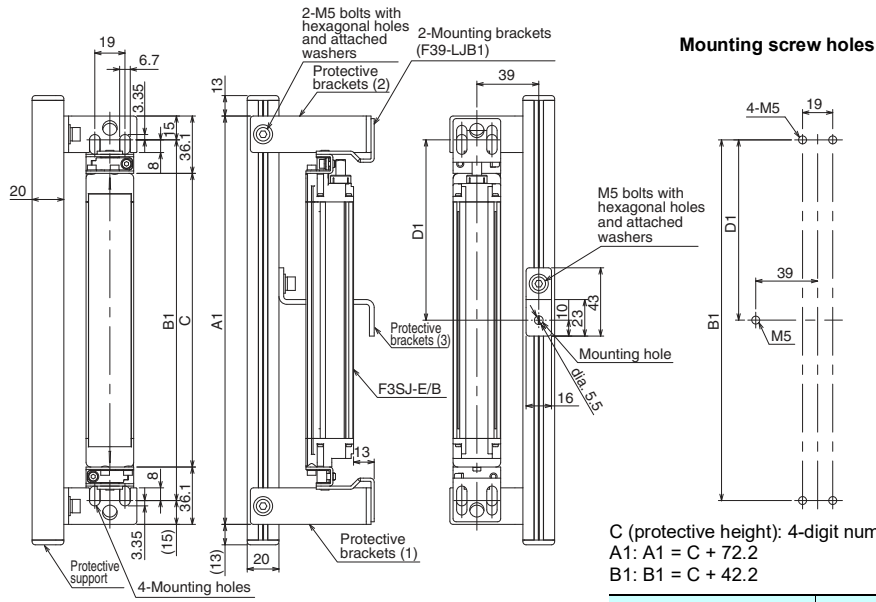

C (protective height): 4-digit number in the Model name
 A1: $A1 = C + 72.2$
 B1: $B1 = C + 42.2$

Protective height	Number of protective brackets (3) used	D1
0185 to 0945	0	---
1025 to 1985	1	B1/2
2065	2	B1/3

Note: For reference, D1 is the dimension that will not interfere with the intermediate bracket on the Safety Light Curtain body.

Backside mounting (using M8 screws)

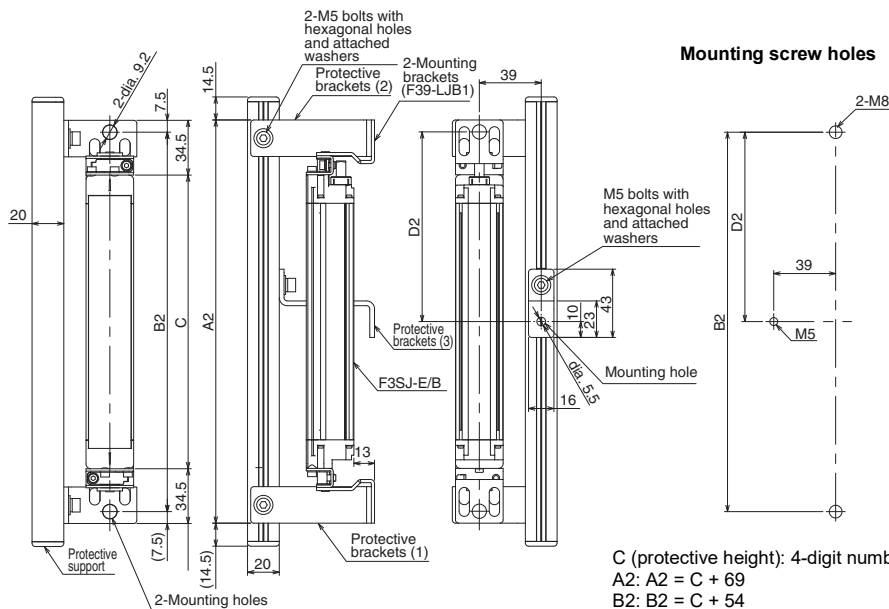

C (protective height): 4-digit number in the Model name
 A2: $A2 = C + 69$
 B2: $B2 = C + 54$

Protective height	Number of protective brackets (3) used	D2
0185 to 0945	0	---
1025 to 1985	1	B2/2
2065	2	B2/3

Note: For reference, D2 is the dimension that will not interfere with the intermediate bracket on the Safety Light Curtain body.

F39-PB□□□□

Side mounting (using M5 screws)

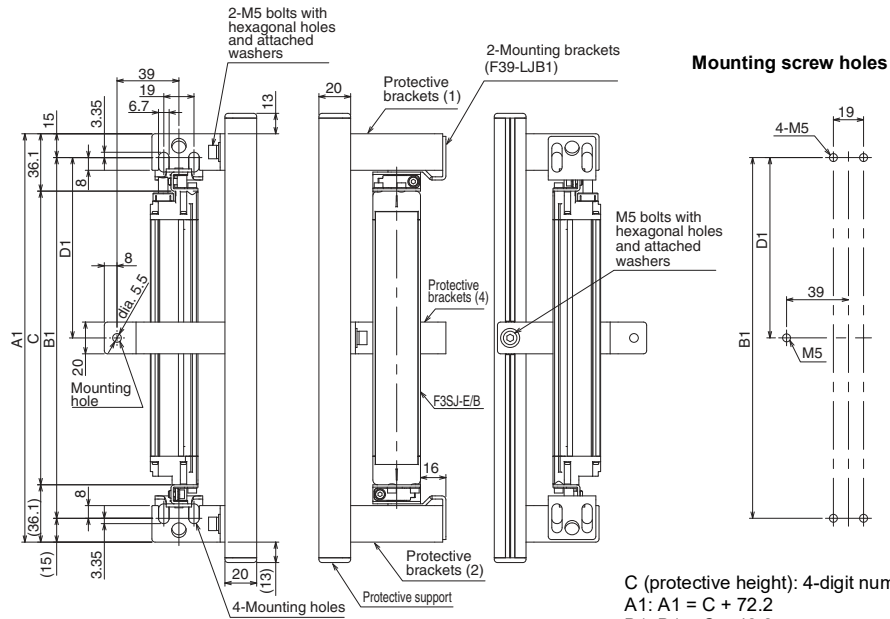

C (protective height): 4-digit number in the Model name
 A1: $A1 = C + 72.2$
 B1: $B1 = C + 42.2$

Protective height	Number of protective brackets (4) used	D1
0185 to 0945	0	---
1025 to 1985	1	B1/2
2065	2	B1/3

Note: For reference, D1 is the dimension that will not interfere with the intermediate bracket on the Safety Light Curtain body.

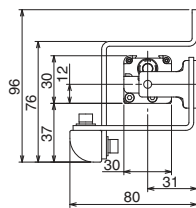

Side mounting (using M8 screws)

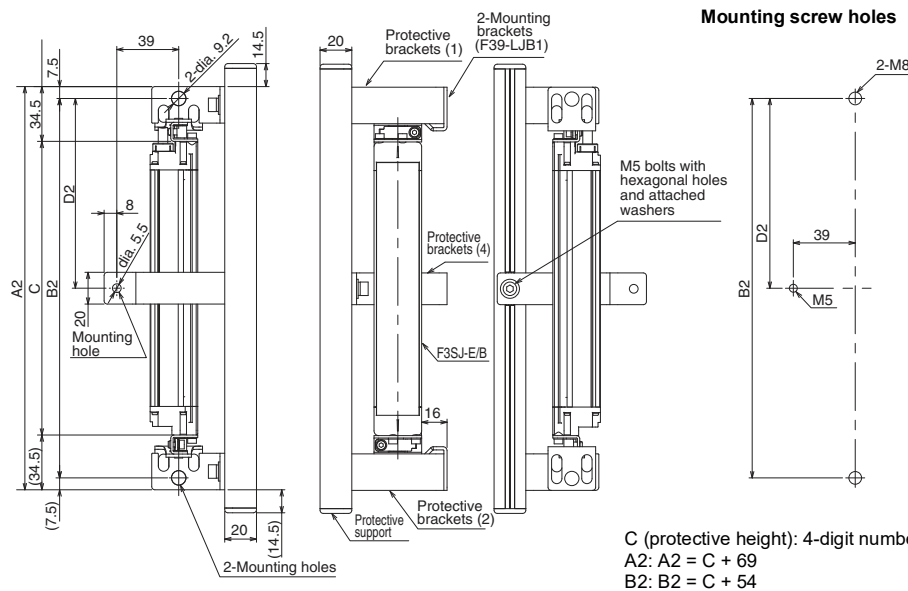

C (protective height): 4-digit number in the Model name
 A2: $A2 = C + 69$
 B2: $B2 = C + 54$

Protective height	Number of protective brackets (4) used	D2
0185 to 0945	0	---
1025 to 1985	1	B2/2
2065	2	B2/3

Note: For reference, D2 is the dimension that will not interfere with the intermediate bracket on the Safety Light Curtain body.

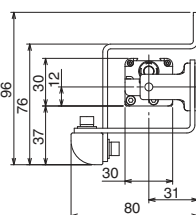

Function List

Functions that can be used on F3SJ are shown as follows: Refer to the F3SJ User's Manual for details. For manual number, check the "Related Manuals" at the end of the catalog.

✓: Can be used.

X: Cannot be used.

Basic functions

Function	F3SJ-E (EASY)	F3SJ-B (BASIC)	F3SJ-A (ADVANCED)
Self-test function	✓	✓	✓
External test function	✓	✓	✓
External device monitoring function	X	✓*1	✓
Interlock function	X	✓*1	✓
Auxiliary output function	X	✓	✓
Muting function *2	X	✓	✓

*1. Cannot be used at muting.

*2. The muting time for the F3SJ-A can be set via the software tool. The muting time for the F3SJ-B cannot be changed.

Functions for individual applications

Override function	X	✓	✓
Partial muting function	X	X	✓
Position detection muting function	X	X	✓
Fixed blanking function	X	X	✓
Floating blanking function	X	X	✓
Warning zone function	X	X	✓
Use of setting tools	X	X	✓

Wiring/mounting related function

Series connection function	X	✓	✓
Dead space less (single connection)	✓	✓	✓
Dead space less (series connection)	X	X	✓
Response time integration (15 ms) *3	✓	✓	X
Simple wiring	✓	X	X
Connector cable	X	✓	
Quick mounting	✓	✓	X
TOP/BOTTOM indicator for beam adjustment	✓	✓	X
Laser Pointer	✓	✓	✓

*3. Convenient to calculate safety distance.

Indicator related functions

External indicator output	X	✓*4	✓*5
Muting error display	X	✓	X

Note: The specifications of the models with the suffixes "-01TS", "-02TS" or "-TS" are different.

Refer to the Specifications.

*4. An external Indicator can be connected to the F3SJ-B auxiliary output .

*5. An external Indicator can be connected to the F3SJ-A auxiliary output 1 and 2, external Indicator 1 and 2 .

Self-test Function

A self-test is performed to check for errors when the power is turned ON. Also, the self-test is regularly performed (within the response time) while operating.

External Test Function

This function stops the emission using an external signal. It can be used to verify that a safety system should properly stop when F3SJ is interrupted.

External Device Monitoring Function

This function detects malfunctions, such as welding, in external relays (or contactors) that control the hazardous part of a machine.

This function constantly monitors that a specified voltage is applied to the receiver's external device monitoring input line, and the system enters lockout state when an error occurs. The relay's operational delay can be up to 300 ms without being evaluated as an error.

For example, if the normally closed N.C. contact does not close within 0.3 s after the safety outputs turn from ON to OFF, and a specified voltage is not applied to the external device monitoring line, it is evaluated as an error and the system enters a lockout state. To utilize this function properly, use safety relays and contactors that have force guided or mechanically linked contact structure.

Interlock Function

The F3SJ turns the safety outputs OFF when its power is turned on or its beam is interrupted and holds this state until reset input is applied. This state is called "interlock".

Two methods can be used to reset the interlock state: "auto reset that automatically turns safety outputs ON when the interrupting object is removed" and "manual reset mode that keeps safety outputs OFF until a reset signal is provided, if the interrupting object is removed".

Auto Reset

When the interrupting object is removed from the detection zone, the safety outputs automatically turn ON. Auto reset is used on machines where a worker is not able to enter the area between the detection zone and the hazardous part of the machine.

Manual Reset

When a reset input is given while no interrupting object exists in a detection zone, the safety outputs turn ON. This allows the machine to be manually reset using a reset switch after ensuring safety, preventing unexpected startup.

Auxiliary Output Function

The auxiliary output is used to monitor the status of the F3SJ. This output can be connected to a device such as programmable controller.

Muting Function

Muting function temporarily disables safety function of the F3SJ, keeping safety output ON even if beams are interrupted. This makes it possible to install safety light curtains for AGV passage, enabling both safety and productivity.

Override Function

The override function turns the safety outputs ON when the muting start condition is not satisfied. If a workpiece stops while passing through the F3SJ, as shown below, causing a muting error, the normal state cannot be recovered unless the workpiece is removed from the muting sensors and the detection field of the F3SJ. However, the override function will mute the safety outputs of the F3SJ so that the conveyor can be restarted to move the workpiece out of the muting sensors and detection zone.

Partial Muting Function

Partial muting function secures safety without enabling muting except for beams when a workpiece passes.

Position Detection Muting

A limit switch or other means is used to detect when the robot is in a safe position, and muting is then applied.

Fixed Blanking Function

Fixed blanking function disables a specific beam of the F3SJ. This function keeps safety output ON even when part of machinery equipment exists within a detection zone.

Floating Blanking Function

Floating blanking function increases the diameter of the F3SJ's detection capability and turns OFF the safety output when multiple objects are detected. When there is a moving object with a fixed width in the detection area that we do not want to detect, the detection function can be disabled.

Warning Zone Function

When an individual enters, a warning lamp lights or buzzer sounds without stopping the equipment by dividing the detection zone into the detection zone and a warning zone.

Setting Tool

The following setting tools (sold separately) can be purchased in order to change or confirm various F3SJ-A parameters.

- F39-MC21 Setting Console
- F39-GWUM SD Manager Setting Support Software for the F3SJ

Series Connection Function

Up to 3 sets of the F3SJ-Bs or up to 4 sets of F3SJ-As can be series-connected. Series connection allows them to be used as a safety light curtain, requiring only one set to be wired to a controller and preventing mutual interference.

Safety Precautions

Description shown below is only a guideline to choose a safety sensor. To use the product properly, you must read its instruction manual that comes with the product.

Legislation and Standards

1. Application of a sensor alone cannot receive type approval provided by Article 44-2 of the Industrial Safety and Health Act of Japan. It is necessary to apply it in a system.
Therefore, when using the F3SJ in Japan as a "safety system for pressing or shearing machines" prescribed in Article 42 of that law, the system must receive type approval.
2. The F3SJ is electro-sensitive protective equipment (ESPE) in accordance with European Union (EU) Machinery Directive Index Annex V, Item 2.
3. The F3SJ-E/B is in conformity with the following standards:
 - (1) EC legislation
Machinery Directive 2006/42/EC
EMC Directive 2014/30/EU
 - (2) European standards
EN 61496-1 (type 4 ESPE),
EN 61496-2 (type 4 AOPD),
EN 61508-1 through -3 (SIL3),
EN 61000-6-4,
EN ISO 13849-1:2015 (PLe/Safety Category 4)
 - (3) International standards
IEC 61496-1 (type 4 ESPE),
IEC 61496-2 (type 4 AOPD),
IEC 61508-1 through -3 (SIL3),
ISO 13849-1:2015 (PLe/Safety Category 4)
 - (4) JIS standards
JIS B 9704-1 (type 4 ESPE),
JIS B 9704-2 (type 4 AOPD)
 - (5) North American standards:
UL 61496-1 (type 4 ESPE),
UL 61496-2 (type 4 AOPD),
UL 508, UL 1998, CAN/CSA C22.2 No.14,
CAN/CSA C22.2 No.0.8
4. The F3SJ-A is in conformity with the following standards:
 - (1) EC legislation
Machinery Directive 2006/42/EC
EMC Directive 2014/30/EU
 - (2) European standards
EN 61496-1 (type 4 ESPE),
EN 61496-2 (type 4 AOPD),
EN 61508-1 through -3 (SIL3),
EN ISO 13849-1:2015 (PLe/Safety Category 4)
 - (3) International standards
IEC 61496-1 (type 4 ESPE),
IEC 61496-2 (type 4 AOPD),
IEC 61508-1 through -3 (SIL3),
ISO 13849-1: 2015 (PLe/Safety Category 4)
- (4) JIS standards
JIS B 9704-1 (type 4 ESPE),
JIS B 9704-2 (type 4 AOPD)
- (5) North American standards:
UL 61496-1 (type 4 ESPE),
UL 61496-2 (type 4 AOPD),
UL 508, UL 1998, CAN/CSA C22.2 No.14,
CAN/CSA C22.2 No.0.8
5. The F3SJ received the following certification from the EU-accredited body, TÜV SÜD Product Service GmbH:
 - EC type test based on machinery directive
Type 4 ESPE (EN 61496-1),
Type 4 AOPD (EN 61496-2)
6. The F3SJ is scheduled to received certificates of UL listing for US and Canadian safety standards from the Third Party Assessment Body UL.
 - Type 4 ESPE (UL 61496-1),
Type 4 AOPD (UL 61496-2)
7. The F3SJ is designed according to the standards listed below. To make sure that the final system complies with the following standards and regulations, you are asked to design and use it in accordance with all other related standards, laws, and regulations. If you have any questions, consult with specialized organizations such as the body responsible for prescribing and/or enforcing machinery safety regulations in the location where the equipment is to be used.
 - European standards: EN 415-4, EN 692, EN 693
 - US Occupational Safety and Health Standards: OSHA 29 CFR 1910.212
 - US Occupational Safety and Health Standards: OSHA 29 CFR 1910.217
 - American National Standards: ANSI B11.1 to B11.19
 - American National Standards: ANSI/RIA 15.06
 - Canadian Standards Association CSA Z142, Z432, Z434
 - SEMI Standards SEMI S2
 - Japan Ministry of Health, Labour and Welfare "Guidelines for Comprehensive Safety Standards of Machinery"
8. We have obtained S-Mark Certification from Legislation and Standards Korea Occupational Safety & Health Agency (KOSHA).
(F3SJ-E□□□□P25-S/F3SJ-B□□□□P25-S/
F3SJ-A□□□□P□□-S)

F3SJ-E/F3SJ-B/F3SJ-A

Precautions on Safety

Indication and meaning for safe use

This instruction manual describes notification and/or warning with indication and symbols as shown below for safe use of F3SJ. This notification describes very important details for safety. You must follow the description. Shown below are indication and symbols.

 WARNING	Indicates a potentially hazardous situation which, if not avoided, will result in minor or moderate injury, or may result in serious injury or death. Additionally there may be significant property damage.
--	--

 CAUTION	If you fail to use a product properly, it may result in injuries or damage on property.
--	---

Meanings of Alert Symbols

	Inhibited Indicates general inhibition.
---	--

Alert Statements in this Manual

F3SJ-E Description applied to F3SJ-E models.

F3SJ-B Description applied to F3SJ-B models.

F3SJ-A Description applied to F3SJ-A models.

For users

 WARNING

F3SJ-E **F3SJ-B** **F3SJ-A**

The F3SJ must be installed, set, and integrated into the mechanical control system by a qualified technician who has received the appropriate training. Failure to make correct settings may prevent detection of people and result in serious injury.

F3SJ-A

When changing parameters with a setting tool (F39-GWUM or F39-MC21), the change must be made and the contents of the change must be managed by the person in charge of the system. Unintentional or mistaken parameter changes may prevent detection of people and result in serious injury.

For machines

 WARNING
--

F3SJ-E **F3SJ-B** **F3SJ-A**

Do not use this sensor for machines that cannot be stopped by electrical control. For example, do not use it for a pressing machine that uses full-rotation clutch. Otherwise, the machine may not stop before a person reaches the hazardous part, resulting in serious injury.

F3SJ-B **F3SJ-A**

Do not use the auxiliary output or external indicator output for safety applications. Human body may not be detected when F3SJ fails, resulting in serious injury.

For installation

 WARNING
--

F3SJ-E **F3SJ-B** **F3SJ-A**

Make sure to test the operation of the F3SJ after installation to verify that the F3SJ operates as intended. Make sure to stop the machine until the test is complete.

Unintended function settings may cause a person to go undetected, resulting in serious injury.

F3SJ-E **F3SJ-B** **F3SJ-A**

Make sure to install the F3SJ at the safe distance from the hazardous part of the equipment. Otherwise, the machine may not stop before a person reaches the hazardous part, resulting in serious injury.

F3SJ-E **F3SJ-B** **F3SJ-A**

Install a protective structure so that the hazardous part of a machine can only be reached by passing through the sensor's detection zone. Install the sensors so that part of the person is always present in the detection zone when working in a machine's hazardous zones. If a person is able to step into the hazardous zone of a machine and remain behind the sensor's detection zone, configure the system with an interlock function that prevents the machine from being restarted. Otherwise it may result in heavy injury.

F3SJ-B **F3SJ-A**

Install the interlock reset switch in a location that provides a clear view of the entire hazardous area and where it cannot be activated from within the hazardous area.

F3SJ-E **F3SJ-B** **F3SJ-A**

The F3SJ cannot protect a person from a projectile exiting the hazardous zone. Install protective cover(s) or fence(s).

F3SJ-A

When detection of an area has been disabled by the fixed blanking function, provide a protective structure around the entire area that will prevent a person from passing through it and reaching the hazardous part of the machinery. Failure to do so may prevent detection of people and result in serious injury.

F3SJ-A

After setting the fixed blanking function, be sure to confirm that a test rod is detected within all areas that require detection. Failure to do so may prevent detection of people and result in serious injury.

F3SJ-A

When the fixed blanking function or the floating blanking function is used, the diameter for the smallest detectable object becomes larger. Be sure to use the diameter for the smallest detectable object for the fixed blanking function or the floating blanking function when calculating the safety distance. Failure to do so may prevent the machinery from stopping before a person reaches the hazardous part of the machinery, and result in serious injury.

F3SJ-B **F3SJ-A**

The muting and override functions disable the safety functions of the device. Additional safety measures must be taken to ensure safety while these functions are working.

F3SJ-B F3SJ-A

Install muting sensors so that they can distinguish between the object that is being allowed to pass through the detection zone and a person. If the muting function is activated by the detection of a person, it may result in serious injury.

F3SJ-B F3SJ-A

Muting lamps (external indicators) that indicate the state of the muting and override functions must be installed where they are clearly visible to workers from all the operating positions.

F3SJ-A

Muting times must be precisely set according to the application by qualified personnel who have received appropriate training. In particular, if the muting time limit is to be set to infinity, the person who makes the setting must bear responsibility.

F3SJ-B F3SJ-A

Use two independent input devices for the muting inputs.

F3SJ-B F3SJ-A

Install the F3SJ, Muting Sensors, or a protective wall so that workers cannot enter hazardous areas while muting is in effect, and set muting times.

F3SJ-B F3SJ-A

Position the switch that is used to activate the override function in a location where the entire hazardous area can be seen, and where the switch cannot be operated from inside the hazardous area. Make sure that nobody is in the hazardous area before activating the override function.

F3SJ-E F3SJ-B F3SJ-A

Install the sensor system so that it is not affected by reflective surfaces. Failure to do so may hinder detection, resulting in serious injury.

F3SJ-E F3SJ-B F3SJ-A

When using more than 1 set of F3SJ, install them so that mutual interference does not occur, such as by configuring series connections or using physical barriers between adjacent sets.

F3SJ-E F3SJ-B F3SJ-A

Make sure that the F3SJ is securely mounted and its cables and connectors are properly secured.

F3SJ-E F3SJ-B F3SJ-A

Make sure that no foreign material, such as water, oil or dust, enters the inside of the F3SJ while the cap is removed.

F3SJ-E F3SJ-B F3SJ-A

Do not use the sensor system with mirrors in a regressive reflective configuration. Doing so may hinder detection. It is possible to use mirrors to "bend" the detection zone to a 90-degree angle.

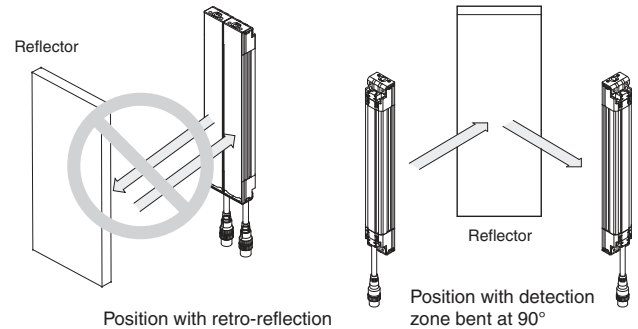

F3SJ-E F3SJ-B F3SJ-A

When using series connections, perform inspection of all connected F3SJs as instructed in the User's Manual.

For wiring

⚠ WARNING

F3SJ-E F3SJ-B F3SJ-A

[For PNP output]

Connect the load between the output and 0V line.

[For NPN output]

Connect the load between the output and +24V line. If +24 V and 0 V are connected, it is dangerous because operation mode is inverted to "ON when interrupted".

F3SJ-E F3SJ-B F3SJ-A

[For PNP output]

Do not short-circuit an output line to +24 V line. Otherwise, the output is always ON. Also, 0 V of the power supply must be grounded so that output should not turn ON due to grounding of the output line.

[For NPN output]

Do not short-circuit an output line to 0 V line. Otherwise, the output is always ON. Also, +24 V of the power supply must be grounded so that output should not turn ON due to grounding of the output line.

F3SJ-E F3SJ-B F3SJ-A

Configure the system by using the optimal number of safety outputs that satisfy the requirements of the necessary safety category.

F3SJ-E F3SJ-B F3SJ-A

Do not connect each line of F3SJ to a DC power supply higher than 24 V+20%. Also, do not connect to an AC power supply. Failure to do so may result in electric shock.

F3SJ-E/F3SJ-B/F3SJ-A

F3SJ-E F3SJ-B F3SJ-A

For F3SJ to comply with IEC 61496-1 and UL 508, the DC power supply unit must satisfy all of the following conditions:

- Must be within rated power voltage (24 VDC±20%).
- Must have tolerance against the total rated current of devices if it is connected to multiple devices.
- Must comply with EMC directives (industrial environment)
- Double or enhanced insulation must be applied between the primary and secondary circuits
- Automatic recovery of overcurrent protection characteristics (reversed L sagging)
- Output holding time must be 20 ms or longer
- Must satisfy output characteristic requirements for class 2 circuit or limited voltage current circuit defined by UL 508
- Must comply with EMC, laws, and regulations of a country or a region where F3SJ is used. (Ex: In EU, the power supply must comply to the EMC Low Voltage Directive)

F3SJ-E F3SJ-B F3SJ-A

Double or enhanced insulation from hazardous voltage must be applied to all input and output lines. Failure to do so may result in electric shock.

F3SJ-E F3SJ-B F3SJ-A

Note: Keep the cable length within the rated length. Failure to do so is dangerous as it may prevent safety functions from operating normally.

F3SJ-E F3SJ-B F3SJ-A

Make sure to perform wiring while the power supply is OFF.

Others F3SJ-E F3SJ-B F3SJ-A

WARNING

To use the F3SJ in PSDI mode (Reinitiation of cyclic operation by the protective equipment), you must configure an appropriate circuit between the F3SJ and the machine. For details about PSDI, refer to OSHA1910.217, IEC 61496-1, and other relevant standards and regulations.

Do not try to disassemble, repair, or modify this product. Doing so may cause the safety functions to stop working properly.

Do not use the F3SJ in environments where flammable or explosive gases are present. Doing so may result in explosion.

Perform daily and 6-month inspections for the F3SJ. Otherwise, the system may fail to work properly, resulting in serious injury.

Do not use radio equipment such as cellular phones, walkie-talkies, or transceivers near the F3SJ.

Note: For customers using the F3SJ-B□□□□P25-01TS:
The functions available are external test, lockout reset, auxiliary output and series connection.

Installation Conditions

Detection Zone and Approach F3SJ-E F3SJ-B F3SJ-A

WARNING

Install a protective structure so that the hazardous part of a machine can only be reached by passing through the sensor's detection zone. Install the sensors so that part of the person is always present in the detection zone when working in a machine's hazardous zones.

If a person is able to step into the hazardous zone of a machine and remain behind the F3SJ's detection zone, configure the system with an interlock function that prevents the machine from being restarted. Failure to do so may result in serious injury.

Install the interlock reset switch in a location that provides a clear view of the entire hazardous zone and where it cannot be activated from within the hazardous zone.

The F3SJ cannot protect a person from a projectile exiting the hazardous zone. Install protective cover(s) or fence(s).

Right positions

The hazardous zone of a machine can be reached only by passing through the sensor's detection zone.



While working, a person is inside the sensor's detection zone.



Incorrect installation

It is possible to reach the hazardous zone of a machine without passing through the sensor's detection zone.



A person is between the sensor's detection zone and the hazardous zone of a machine.

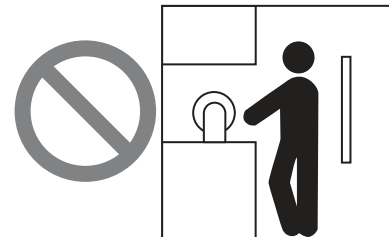

Safety Safety Distance F3SJ-E F3SJ-B F3SJ-A

The safety distance is the distance that must be set between the F3SJ and a machine's hazardous part to stop the hazardous part before a person or object reaches it. The safety distance varies according to the standards of each country and the individual specifications of each machine. In addition, the calculation of the safety distance differs if the direction of approach is not vertical to the detection zone of the F3SJ. Always refer to relevant standards.

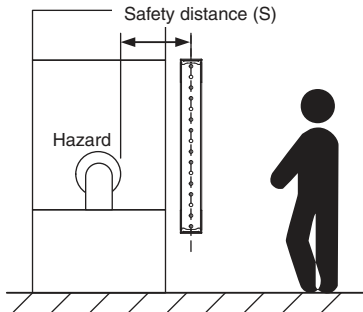

WARNING

Make sure to secure the safety distance (S) between the F3SJ and the hazardous part. Failure to do so may prevent the machinery from stopping before a person reaches the hazardous part of the machinery, and result in serious injury.

Note: The response time of a machine is the time period from when the machine receives a stop signal to when the machine's hazardous part stops. Measure the response time on the actual system. Also, periodically check that the response time of the machine has not changed.

How to calculate the safety distance specified by International Standard ISO 13855 (European Standard EN ISO 13855) (Reference)

Detection Zone Orthogonal to Direction of Approach

$S = K \times T + C$. . . Formula (1)

- S: Safety distance
- K: Approach speed to the detection zone
- T: Total response time of the machine and F3SJ
- C: Additional distance calculated by the detection capability of the F3SJ

<System with a detection capability of 40 mm max.>

Use $K = 2,000 \text{ mm/s}$ and $C = 8 \times (d - 14 \text{ mm})$ in equation (1) for the calculation.

$S = 2,000 \text{ mm/s} \times (T_m + T_s) + 8 \times (d - 14 \text{ mm})$

- S = Safety distance (mm)
- T_m = Machine's response time (s)
- T_s = Response time of the F3SJ from ON to OFF (s)
- d = Size of F3SJ's detection capability (mm)

[Calculation example]

When $T_m = 0.05 \text{ s}$, $T_s = 0.01 \text{ s}$, and $d = 14 \text{ mm}$:

$S = 2,000 \text{ mm/s} \times (0.05 \text{ s} + 0.01 \text{ s}) + 8 \times (14 \text{ mm} - 14 \text{ mm})$
 $= 120 \text{ mm}$. . . Formula (2)

If the result is less than 100 mm, use $S = 100 \text{ mm}$.

If the result exceeds 500 mm, use the following formula where $K = 1,600 \text{ mm/s}$.

$S = 1,600 \text{ mm/s} \times (T_m + T_s) + 8 \times (d - 14 \text{ mm})$. . . Formula (3)

If the result of this Formula (3) is less than 500 mm,

$S = 500 \text{ mm}$

<System with a detection capability larger than 40 mm>

Use $K = 1,600 \text{ mm/s}$ and $C = 8 \times (d - 850 \text{ mm})$ in equation (1) for the calculation.

$S = 1,600 \text{ mm/s} \times (T_m + T_s) + 850 \times (d - 14 \text{ mm})$... Formula (4)

- S = Safety distance (mm)
- T_m = Machine's response time (s)
- T_s = Response time of the F3SJ from ON to OFF (s)

[Calculation example]

When $T_m = 0.05 \text{ s}$, $T_s = 0.01 \text{ s}$:

$S = 1,600 \text{ mm/s} \times (0.05 \text{ s} + 0.01 \text{ s}) + 850 \text{ mm}$
 $= 946 \text{ mm}$

F3SJ-E/F3SJ-B/F3SJ-A

Possible Circumventing by Reaching Over the Detection Zone

If access to the hazardous zone by reaching over the detection zone of vertically mounted F3SJ cannot be excluded, the height and the safety distance, S, of the F3SJ shall be determined. S shall be determined by comparison of the calculated values in *Detection Zone Orthogonal to Direction of Approach*. The greater value resulting from this comparison shall be applied.

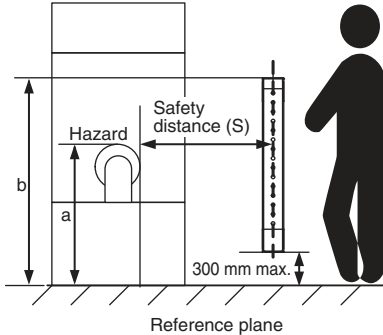

$$S = (K \times T) + Cro \dots \text{Formula (5)}$$

- S: Safety distance
- K: Approach speed to the detection zone
- T: Total response time of the machine and F3SJ
- Cro: Approach distance based on the distance which personnel can move towards the hazardous zone of a machine by reaching over the detection zone. The distance is determined in the table below based on the height of the hazardous zone, a, and the height of the upper edge of the detection zone, b.

Note: Lower edge of the detection zone above 300 mm in relation to the reference plane does not offer sufficient protection against crawling below.

First, use $K = 2,000 \text{ mm/s}$ in formula (5) for the calculation. If the result of this calculation is less than 100 mm, use $S = 100 \text{ mm}$. If the result exceeds 500 mm, use $K = 1,600 \text{ mm/s}$ to recalculate it. If the result of the recalculation is less than 500 mm, use $S = 500 \text{ mm}$.

Height of hazardous zone, a	Height of upper edge of detection zone, b											
	900	1000	1100	1200	1300	1400	1600	1800	2000	2200	2400	2600
Additional distance to hazardous zone, Cro												
2600	0	0	0	0	0	0	0	0	0	0	0	0
2500	400	400	350	300	300	300	300	300	250	150	100	0
2400	550	550	550	500	450	450	400	400	300	250	100	0
2200	800	750	750	700	650	650	600	550	400	250	0	0
2000	950	950	850	850	800	750	700	550	400	0	0	0
1800	1100	1100	950	950	850	800	750	550	0	0	0	0
1600	1150	1150	1100	1000	900	850	750	450	0	0	0	0
1400	1200	1200	1100	1000	900	850	650	0	0	0	0	0
1200	1200	1200	1100	1000	850	800	0	0	0	0	0	0
1000	1200	1150	1050	950	750	700	0	0	0	0	0	0
800	1150	1050	950	800	500	450	0	0	0	0	0	0
600	1050	950	750	550	0	0	0	0	0	0	0	0
400	900	700	0	0	0	0	0	0	0	0	0	0
200	600	0	0	0	0	0	0	0	0	0	0	0
0	0	0	0	0	0	0	0	0	0	0	0	0

- Note:**
1. Upper edge of the detection zone below 900 mm is not included since they do not offer sufficient protection against circumventing or stepping over.
 2. When determining the values of this table, it shall not be interpolated. If the known values a, b or Cro are between two values of this table, the greater safety distance shall be used.

[Calculation example]

- T: $T_m + T_s$ (s)
- T_m : Machine's response time (s)
- T_s : Response time of the F3SJ from ON to OFF (s)
- a: Height of machine hazardous zone (mm)
- b: Height of upper edge of detection zone (mm)

When $T_m = 0.05 \text{ s}$, $T_s = 0.01 \text{ s}$, $a = 1,400 \text{ mm}$, $b = 1,500 \text{ mm}$:
From the table above, $Cro = 850 \text{ mm}$. Since b is between 1,400 mm and 1,600 mm, $b = 1,400 \text{ mm}$ which has the greater Cro value, shall be used.

$$S = 2,000 \text{ mm/s} \times (0.05 \text{ s} + 0.01 \text{ s}) + 850 \text{ mm} = 970 \text{ mm}$$

Since 970 mm is greater than 500 mm, use $K = 1,600 \text{ mm/s}$ and recalculate it.

$$S = 1,600 \text{ mm/s} \times (0.05 \text{ s} + 0.01 \text{ s}) + 850 \text{ mm} = 946 \text{ mm}$$

Compare $S = 946 \text{ mm}$ with the calculation in Detection Zone Orthogonal to Direction of Approach, and choose the larger value as the safety distance.

For the system with a detection capability of 40 mm max., the safety distance S is 946 mm since this is larger than $S = 120 \text{ mm}$ calculated in the calculation example of Detection Zone Orthogonal to Direction of Approach.

For the system with a detection capability larger than 40 mm, the safety distance S is 946 mm since this is the same value as $S = 946 \text{ mm}$ calculated in the calculation example of Detection Zone Orthogonal to Direction of Approach.

Detection Zone Parallel to Direction of Approach

Use $K = 1,600 \text{ mm/s}$ and $C = (1200 - 0.4 \times H)$ in formula (1) for calculation. Note that C must not be less than 850 mm.

$$S = 1,600 \text{ mm/s} \times (T_m + T_s) + 1200 - 0.4 \times H$$

- S: Safety distance (mm)
- T_m = Machine's response time (s)
- T_s = Response time of F3SJ from ON to OFF (s)
- H = Installation height (mm)

Note that H must satisfy:

$$1000 \geq H \geq 15 (d - 50 \text{ mm}) \geq 0 \text{ mm}$$

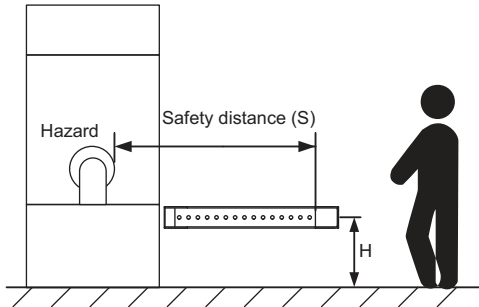

Also, you must include a hazardous condition under which a person may go through under a detection zone if H exceeds 300 mm (200 mm for other purpose than industrial use) into risk assessment.

[Calculation example]

When $T_m = 0.05 \text{ s}$, $T_s = 0.01 \text{ s}$, and $d = 14 \text{ mm}$:

$$S = 1,600 \text{ mm/s} \times (0.05 \text{ s} + 0.01 \text{ s}) + 1200 - 0.4 \times 500 \text{ mm} = 1096 \text{ mm}$$

When a warning zone is configured as in the figure, you must calculate L, a distance from an end of casing to a detection zone, using a formula below:

$$L = (\text{Total number of F3SJ beams} - \text{number of warning zone beams} - 1) \times P + 10$$

- P: Beam Gap (mm)
- F3SJ-A□□□□P14/N14 . . . 9 mm
- F3SJ-A□□□□P20/N20 . . . 15 mm
- F3SJ-A□□□□P25/N25 . . . 20 mm
- F3SJ-A□□□□P30/N30 . . . 25 mm
- F3SJ-A□□□□P55/N55 . . . 50 mm

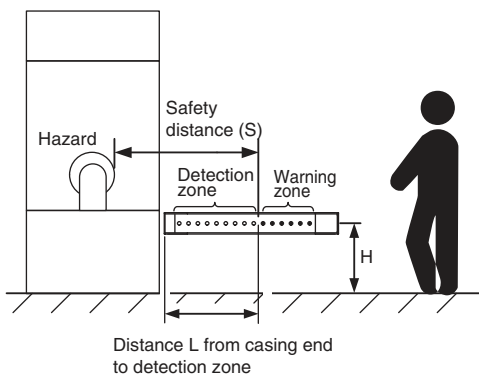

Refer to the F3SJ User's Manual for details. For manual number, check the "Related Manuals" at the end of the catalog.

How to calculate the safety distance specified by American standard ANSI B11.19 (Ref.)

If a person approaches the detection zone of the F3SJ orthogonally, calculate the safety distance as shown below.

$$S = K \times (T_s + T_c + T_r + T_{bm}) + D_{pf}$$

- S: Safety distance
- K: Approach speed to the detection zone

(the value recommended by OSHA standard is 1,600 mm/s)

Approach speed K is not specified in the ANSI B.11.19 standard. To determine the value of K to apply, consider all factors, including the operator's physical ability.

- T_s = Machine's stop time (s)
- T_s = Response time of the F3SJ from ON to OFF (s)
- T_c = Machine control circuit's maximum response time required to activate its brake (s)
- T_{bm} = Additional time (s)

If a machine has a brake monitor, " T_{bm} = Brake monitor setting time - ($T_s + T_c$)". If it has no brake monitor, we recommend using 20% or more of ($T_s + T_c$) as additional time.

- D_{pf} = Additional distance

According to ANSI's formula, D_{pf} is calculated as shown below:
 $D_{pf} = 3.4 \times (d - 7.0)$: Where d is the detection capability of the F3SJ (unit: mm)

[Calculation example]

When $K = 1,600 \text{ mm/s}$, $T_s + T_c = 0.06 \text{ s}$, brake monitor setting time = 0.1 s, $T_r = 0.01 \text{ s}$, and $d = 14 \text{ mm}$:

$$T_{bm} = 0.1 - 0.06 = 0.04 \text{ s}$$

$$D_{pf} = 3.4 \times (14 - 7.0) = 23.8 \text{ mm}$$

$$S = 1,600 \text{ mm/s} \times (0.06 \text{ s} + 0.01 \text{ s} + 0.04 \text{ s}) + 23.8 \text{ mm} = 199.8 \text{ mm}$$

F3SJ-E/F3SJ-B/F3SJ-A

Distance from Reflective Surface F3SJ-E F3SJ-B F3SJ-A

WARNING

Install the sensor system so that it is not affected by reflection from a reflective surface. Failure to do so may hinder detection, resulting in serious injury.

Install the sensor system at distance D or further from highly reflective surfaces such as metallic walls, floors, ceilings, or workpieces, as shown below.

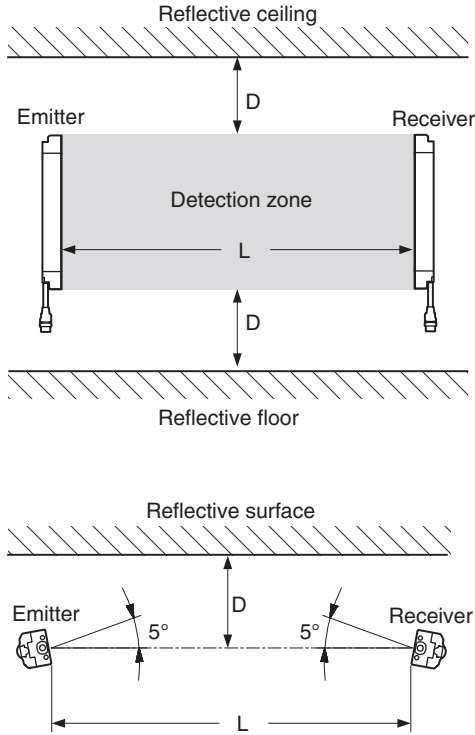

Distance between emitter and receiver (operating range L)	Allowable installation distance D
For 0.2 to 3 m	0.13 m
For 3 m or more	$L/2 \times \tan 5^\circ = L \times 0.044$ (m)

Mutual Interference Prevention F3SJ-E F3SJ-B F3SJ-A

WARNING

Do not use the sensor system with mirrors in a regressive reflective configuration. Doing so may hinder detection. It is possible to use mirrors to "bend" the detection zone to a 90-degree angle.

When using more than 1 set of F3SJ, install them so that mutual interference does not occur, such as by configuring series connections or using physical barriers between adjacent sets.

Mutual interference from other F3SJ is prevented in up to 3 sets without series connection.

For series connection F3SJ-B F3SJ-A

Series connection can prevent mutual interference when multiple sensors are used. Up to 3 sets with 192 beam for F3SJ-B series, or up to 4 sets with 400 beams for F3SJ-A series can be series-connected. Emission of series-connected F3SJ is time-divided, ensuring safety without occurring mutual interference.

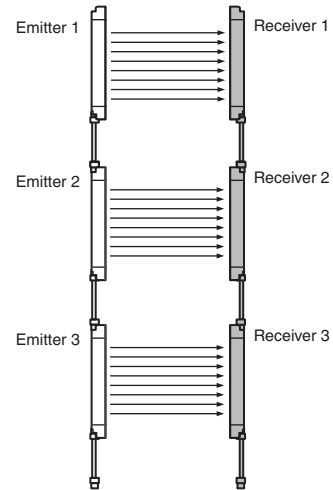

No series connections **F3SJ-B** **F3SJ-A**

Mutual interference is prevented in up to three sets, using interference light detection and cycle shift algorithm.
 If 4 or more sets of F3SJs are installed and are not connected to each other, arrange them so that mutual interference does not occur.
 If two sets are installed near each other, reflection from the surface of the F3SJ may cause mutual interference. When mutual interference occurs, the safety outputs are turned OFF momentarily or the F3SJ enters lockout state. Combining countermeasures 1 to 3 shown below is effective.

1. Install a physical barrier

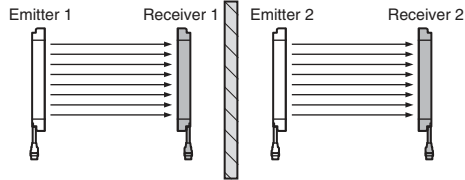

2. Alternate the direction of emission (alternation)

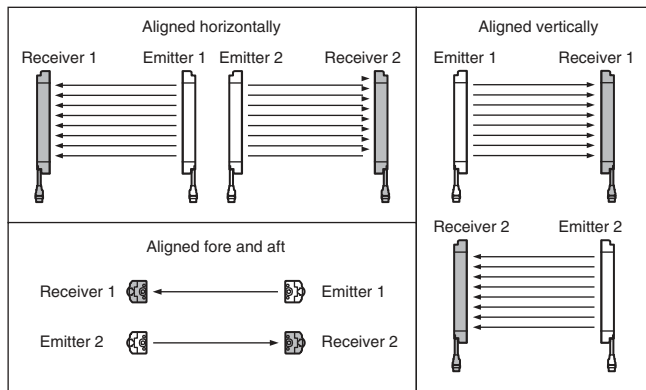

3. Keep sufficient distance between the F3SJs so that mutual interference does not occur

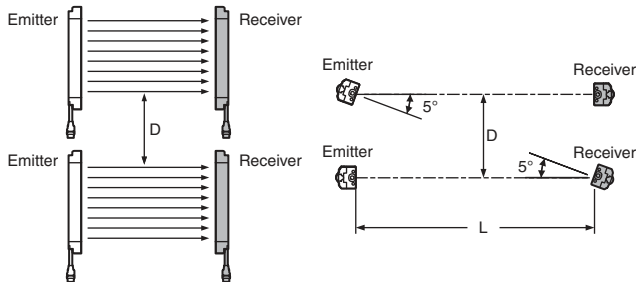

Distance between emitter and receiver (operating range L)	Allowable installation distance D
For 0.2 to 3 m	0.26 m
For 3 m or more	$L \times \tan 5^\circ = L \times 0.088 \text{ (m)}$

Installation shown below may cause mutual interference. When mutual interference occurs, the safety outputs are turned OFF momentarily or the F3SJ enters lockout state.

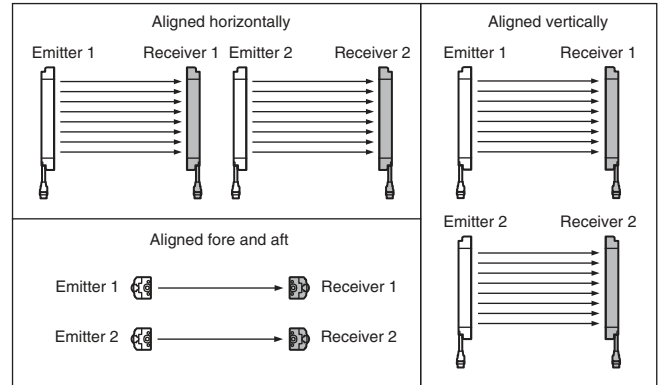

F3SJ-A

If two sets are installed near each other, reflection from the surface of the F3SJ may cause mutual interference. Use of F3SJ-A can improve the condition by shortening operating range with the setting tool.

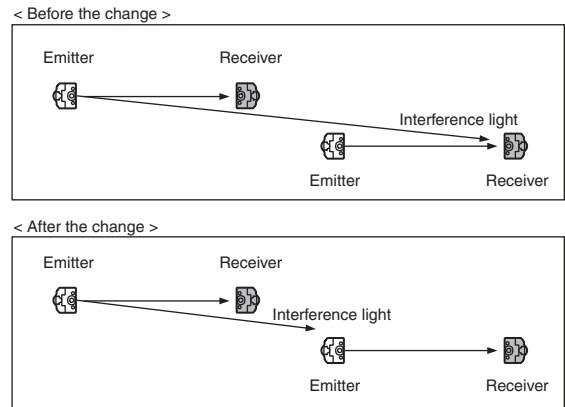

F3SJ-E/F3SJ-B/F3SJ-A

Related Manuals

Man. No.	Model	Manual name
SCHG-718	F3SJ-A□□□□P□□	F3SJ-A□□□□P□□ (Ver.2) Safety Light Curtain User's Manual
SCHG-720	F3SJ-A□□□□P□□-TS	F3SJ-A□□□□P□□-TS Safety Light Curtain User's Manual
SCHG-722	F3SJ-A□□□□P□□-01TS	F3SJ-A□□□□P□□-01TS Safety Light Curtain User's Manual
SCHG-719	F3SJ-A□□□□N□□	F3SJ-A□□□□N□□(Ver.2) Safety Light Curtain User's Manual
SCHG-726	F3SJ-A□□□□N□□-01T	F3SJ-A□□□□N□□-01T(Ver.2) Safety Light Curtain User's Manual
SCHG-716	F3SJ-AM□P□□□	F3SJ-AM□P□□□(Ver.2) Multi-beam Safety Sensor User's Manual
SCHG-734	F3SJ-B□□□□P25-01TS	F3SJ-B□□□□P25-01TS Safety Light Curtain User's Manual
SCHG-733	F3SJ-E□□□□N25/B□□□□N25	F3SJ-E□□□□N25/B□□□□N25 Safety Light Curtain User's Manual
SCHG-732	F3SJ-E□□□□P25/B□□□□P25	F3SJ-E□□□□P25/B□□□□P25 Safety Light Curtain User's Manual
SCHG-712	F39-MC21	F39-MC21 F39-MC21 Setting Console Instruction Sheet
SCHG-736	F3SJ-B□□□□P25-02TS	F3SJ-B□□□□P25-02TS Safety Light Curtain User's Manual

OMRON AUTOMATION AMERICAS HEADQUARTERS • Chicago, IL USA • 847.843.7900 • 800.556.6766 • automation.omron.com

OMRON CANADA, INC. • HEAD OFFICE

Toronto, ON, Canada • 416.286.6465 • 866.986.6766 • automation.omron.com

OMRON ELECTRONICS DE MEXICO • HEAD OFFICE

Ciudad de México • 52.55.5901.4300 • 01.800.386.6766 • mela@omron.com

OMRON ELECTRONICS DE MEXICO • SALES OFFICE

San Pedro Garza García, N.L. • 81.12.53.7392 • 01.800.386.6766 • mela@omron.com

OMRON ELECTRONICS DE MEXICO • SALES OFFICE

Eugenio Garza Sada, León, Gto • 01.800.386.6766 • mela@omron.com

OMRON ELETRÔNICA DO BRASIL LTDA • HEAD OFFICE

São Paulo, SP, Brasil • 55 11 5171-8920 • automation.omron.com

OMRON ARGENTINA • SALES OFFICE

Buenos Aires, Argentina • +54.11.4521.8630 • +54.11.4523.8483
mela@omron.com

OTHER OMRON LATIN AMERICA SALES

+54.11.4521.8630 • +54.11.4523.8483 • mela@omron.com

Authorized Distributor:

Controllers & I/O

- Machine Automation Controllers (MAC) • Motion Controllers
- Programmable Logic Controllers (PLC) • Temperature Controllers • Remote I/O

Robotics

- Industrial Robots • Mobile Robots

Operator Interfaces

- Human Machine Interface (HMI)

Motion & Drives

- Machine Automation Controllers (MAC) • Motion Controllers • Servo Systems
- Frequency Inverters

Vision, Measurement & Identification

- Vision Sensors & Systems • Measurement Sensors • Auto Identification Systems

Sensing

- Photoelectric Sensors • Fiber-Optic Sensors • Proximity Sensors
- Rotary Encoders • Ultrasonic Sensors

Safety

- Safety Light Curtains • Safety Laser Scanners • Programmable Safety Systems
- Safety Mats and Edges • Safety Door Switches • Emergency Stop Devices
- Safety Switches & Operator Controls • Safety Monitoring/Force-guided Relays

Control Components

- Power Supplies • Timers • Counters • Programmable Relays
- Digital Panel Meters • Monitoring Products

Switches & Relays

- Limit Switches • Pushbutton Switches • Electromechanical Relays
- Solid State Relays

Software

- Programming & Configuration • Runtime