

Evaluation Board For the Si30xx with the Standard Serial Interface

Overview

The Si30xxSSI-EVB provides the modem system designer an easy way to evaluate the Si30xx solution. Silicon Labs' DAAs are integrated direct access arrangements that provide a digital, low-cost, solid state interface to FCC-compliant or worldwide telephone lines. Through the patented ISOcap™ technology, the Si30xx eliminates the need for an analog front end (AFE), an isolation transformer, relays, opto-isolators, and a 2- to 4-wire hybrid.

The evaluation board (EVB) provides an RJ-11 connector and a 10-pin stake header for connecting the designer's target modem DSP or ASIC through the Si30xx to the phone line. This arrangement allows for a straightforward comparison of the existing modem's AFE and DAA to the innovative Si30xx. In addition, two 10-pin headers are available for easy evaluation of the daisy-chaining feature.

Power is supplied through two terminal blocks, V_D and V_A . This allows for 5 V or 3.3 V operation of the evaluation board. The Si30xxSSI-EVB supports a connection for an optional call progress speaker.

Features

The Si30xxSSI-EVB includes the following:

- RJ-11 connection to phone line
- Buffered digital I/O interface to DSP or ASIC
- Recommended layout for key components
- Connection for an optional call progress speaker
- Easy power connection for 5 V or 3.3 V operation
- Flexible MCLK scheme
- User selectable serial mode
- Support for daisy chain operation
- Motherboard–daughter card connection

Function Block Diagram

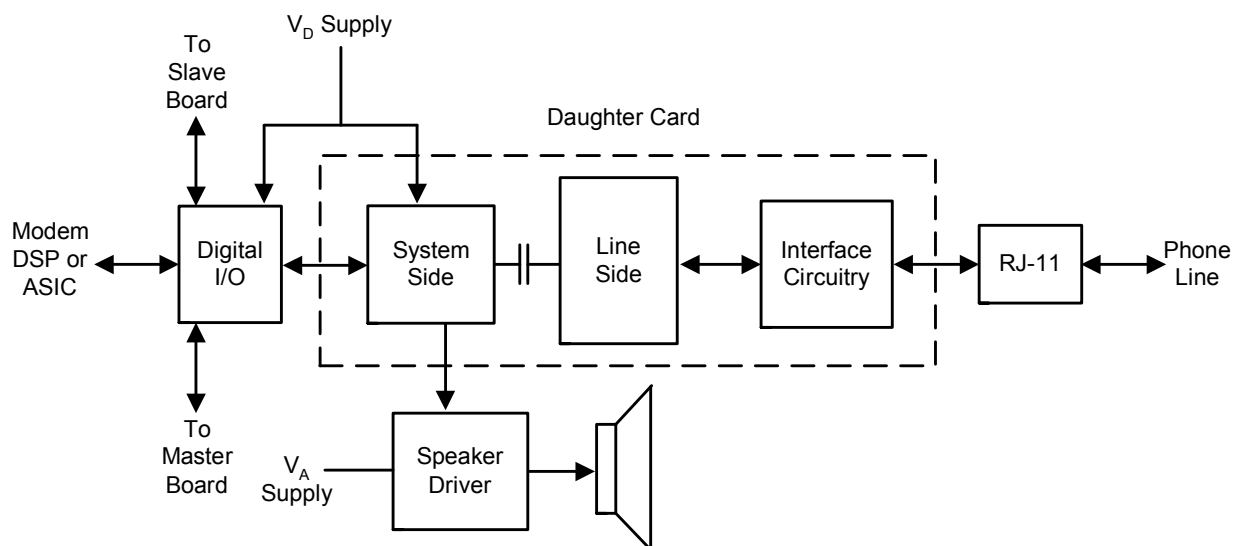

Si30xxSSI-EVB

Functional Description

The Si30xxSSI-EVB provides an easy way to evaluate the Si30xx solution. The evaluation board provides an RJ-11 connector and a 10-pin stake header for connecting a target modem DSP or ASIC through the Si30xx to the phone line. This arrangement allows for a straightforward comparison of the existing modem's AFE and DAA to the innovative Si30xx.

This Si30xx chipset also supports the connection of multiple devices on a single serial interface. The evaluation board provides a straightforward means of evaluating this feature.

The evaluation board consists of the Si30xxSSI-EVB motherboard and the Si30xx DC-EVB daughter card. The Si30xxSSI-EVB can be used with other Silicon Laboratories daughter cards, such as the Si3000DC-EVB. Contact a Silicon Laboratories representative for more information.

Motherboard–Daughter Card Connection

The Si30xx DC-EVB connects to the Si30xxSSI-EVB through two sockets, JP1 and JP2.

JP1 is a 3x8 socket connection to the digital signals of the system side, as well as the AOUT. In addition, the V_D power of the Si30xxSSI-EVB (J2) is routed to this socket and supplies the power to the system side. JP1 connects to JP7 of the Si30xxSSI-EVB.

JP2 is a 2x5 socket connection to the TIP and RING and chassis ground of the line interface to the line side. JP2 connects to JP8 of the Si30xxSSI-EVB.

Power Supply

Power is supplied to the EVB by means of J2 and J3 when the board is used in stand-alone mode. If multiple boards are cascaded together, refer to “Daisy-Chain Operation” for the power supply requirements.

J2 and J3 are euroblock headers which allow for connection to a bench power supply. J2 provides the power for all devices connected to the V_D node. J3 provides the power for the V_A node.

When using an Si3034/35/44 daughter card, J2 can nominally be 3.3 V or 5 V. If $V_D = 3.3$ V, then R3 (of the Si30xx DC-EVB) should be removed, and the CPE bit of register 6 should be set. U3 and U4 can operate from either 3.3 V or 5 V. If Y1 is used, it must support 3.3 V operation. When using an Si3056 daughter card, J2 should only be connected by a 3.3 V supply.

J3 must be nominally 5 V. This connector provides the supply to the analog speaker section. Pin 13 (V_A) of U1 does not connect to this supply.

Diodes D4 and D5 are used to protect the EVB against over-voltage or accidental terminal reversal. They are rated at 6.8 V.

Clock Generation

The system side requires an MCLK input. The Si30xxSSI-EVB provides two options for this requirement. MCLK can be provided via pin 1 of JP4 from the target system or from an oscillator installed in Y1. JP3 selects the MCLK source to the system side. In the Y1 position, the oscillator installed in Y1 is connected. If 3.3 V is the V_D supply, Y1 must be a 3.3 V oscillator. In the JP4 position, the clock on JP4 is connected. Valid MCLK frequencies range from 1 to 60 MHz.

If multiple boards are cascaded together, refer to the section on daisy-chain operation. Only the master board needs an MCLK from Y1 or JP4.

Optional Call Progress Speaker

The AOUT pin of the system side provides monitoring of call progress. U5 provides 25 dB of signal gain on this output. The AOUT pin has an output impedance of 10 k Ω . R15 and R19 form a voltage divider that provides a gain of -24.4 dB. This divider is necessary so the LM386, which is operating from a 5 V supply, is not overdriven.

The LM386 is a cost-effective low-power amplifier capable of driving many different buzzers or speakers.

In the case of cascaded evaluation boards, the AOUT signal is local to each board.

Reset Circuit

The Si30xx requires an active low pulse on \overline{RST} following power up and whenever all registers need to be reset. Typically, the target system generates this signal and supplies it on pin 9 of JP4. For development purposes, the Si30xxSSI-EVB includes a reset push button, SW1, that is a logic OR (active low) with the reset signal from the target system. U4 provides the reset logic and serves as a buffer. This circuit is not necessary in a production design.

If multiple boards are cascaded together, the reset signal should be generated by the master board. Using the SW1 pushbutton on slave boards will only reset that slave board and slave boards further down the chain.

Serial Modes

The Si30xx supports two different serial modes for a glueless interface to many standard DSP and ASIC serial ports. The serial mode of the Si30xx can be selected by JP1 and JP2.

Table 1. Si30xx Serial Modes

M1	M0	Mode
GND	GND	FSYNC frames data, Master
GND	V _D	FSYNC pulse starts data frame, Master
V _D	GND	Slave Operation
V _D	V _D	Reserved

The default mode is FSYNC frames data.

The FC signal on JP4 is tied to ground through a 47 kΩ resistor (R29). If FC is used in the system, this resistor must be removed.

Several additional signals are required for proper operation of the serial interface. As mentioned in the clock generation section, an MCLK must be provided for the Si30xx to operate.

FSYNC, SCLK, SDI and SDO are also required signals to operate the Si30xx. FSYNC provides the synchronization for the modem samples. This signal operates at the sample rate. A high to low transition marks the beginning of a new frame.

SCLK is an output of the Si30xx providing the bit clock for the modem samples. Data is valid on the falling edge of SCLK following an FSYNC start transition. SDI consists of modem samples to be transmitted down the phone line, and SDO consists of modem samples from the down-line system.

The serial port signals are also used during a secondary frame to read and write the internal registers of the Si30xx. Refer to the Si30xx data sheet for more details on internal registers and how to read and write those registers.

When using the board in stand-alone mode (single), SW2 = 1 and SW3 = 1. Figure 1 shows a typical configuration in stand-alone mode.

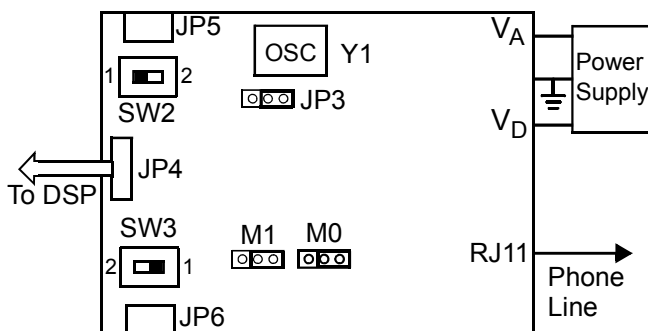

Figure 1. Stand-Alone Connections

Daisy-Chain Operation

The Si30xx supports an additional serial mode which places the device in a slave mode. This serial mode is accomplished by M1 = V_D and M0 = GND.

The Si30xxSSI-EVB can essentially be used in three modes: stand-alone (single), master, and slave. Table 2 shows the configurations necessary for each mode.

Table 2. Si30xxSSI-EVB Modes

Configuration	SW2	SW3	M1	M0
Single	1	1	GND	X
Master	1	2	GND	V _D
Slave	2	2	V _D	GND

In addition to JP1 and JP2 (which control the serial mode of the local system side), SW2 and SW3 are used to route the digital signals to ensure proper connection.

Multiple Si30xxSSI-EVBs can be connected through JP5 and JP6. Figure 2 shows the connection of three Si30xxSSI-EVBs in daisy-chain mode.

Si30xxSSI-EVB

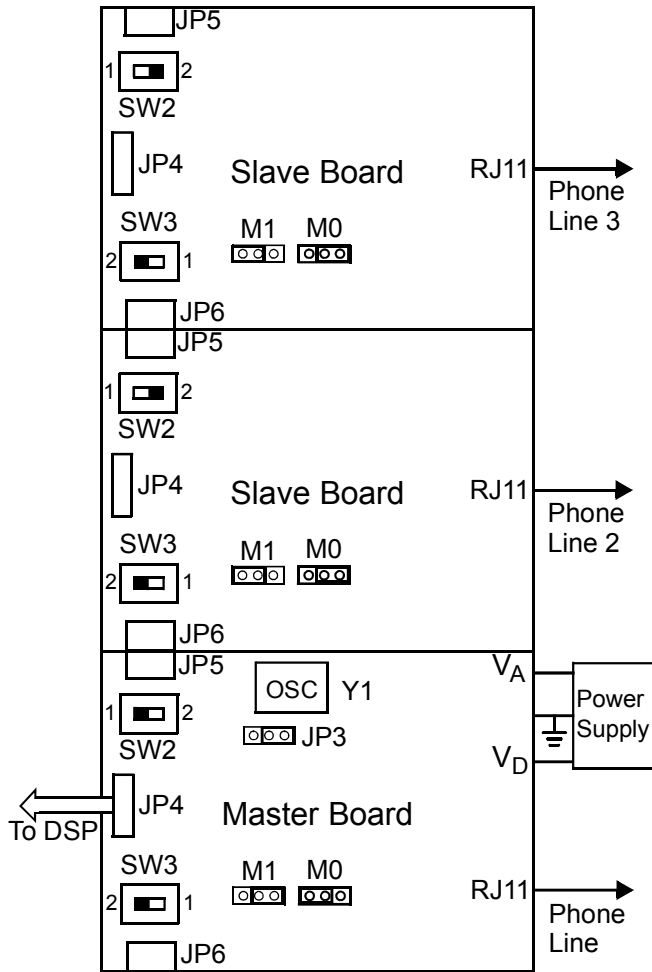

Figure 2. Daisy-Chain Connections

The DSP or ASIC connects directly to the master board. Only the master board needs a connection to a power supply. V_D and V_A are routed through JP5 and JP6.

When the Si30xxSSI-EVB is used as a master board, the serial mode must be $M1 = \text{GND}$ and $M0 = V_D$. When the Si30xxSSI-EVB is used as a slave board, the serial mode must be $M1 = V_D$ and $M0 = \text{GND}$. Be sure to configure SW2 and SW3 appropriately according to Table 2.

A test point, RGDT, near JP4 has been provided on each Si30xxSSI-EVB to provide easy access to the local ring detect signal of the system side. The ring detection signal is also reflected in the SDO stream from each system side.

Line Connection

J1 is provided to connect to a standard RJ-11 connector. The system cannot execute an off-hook without the phone line connected. This error condition can be detected by examining the FDT bit of Register 12 or by simply observing there is no dial tone to the DSP or ASIC.

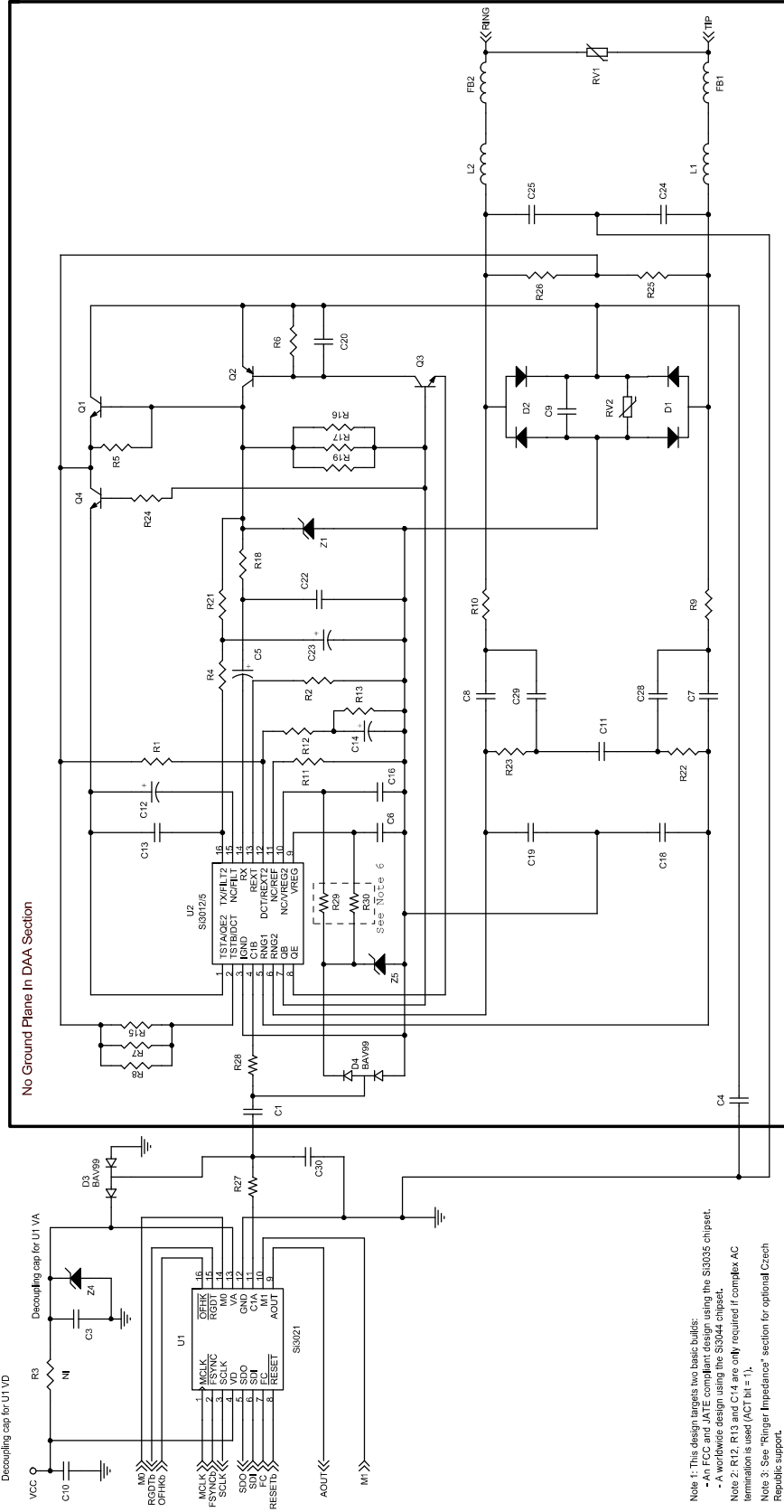
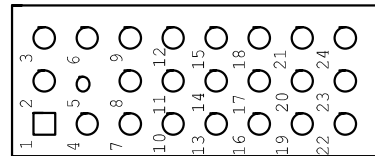
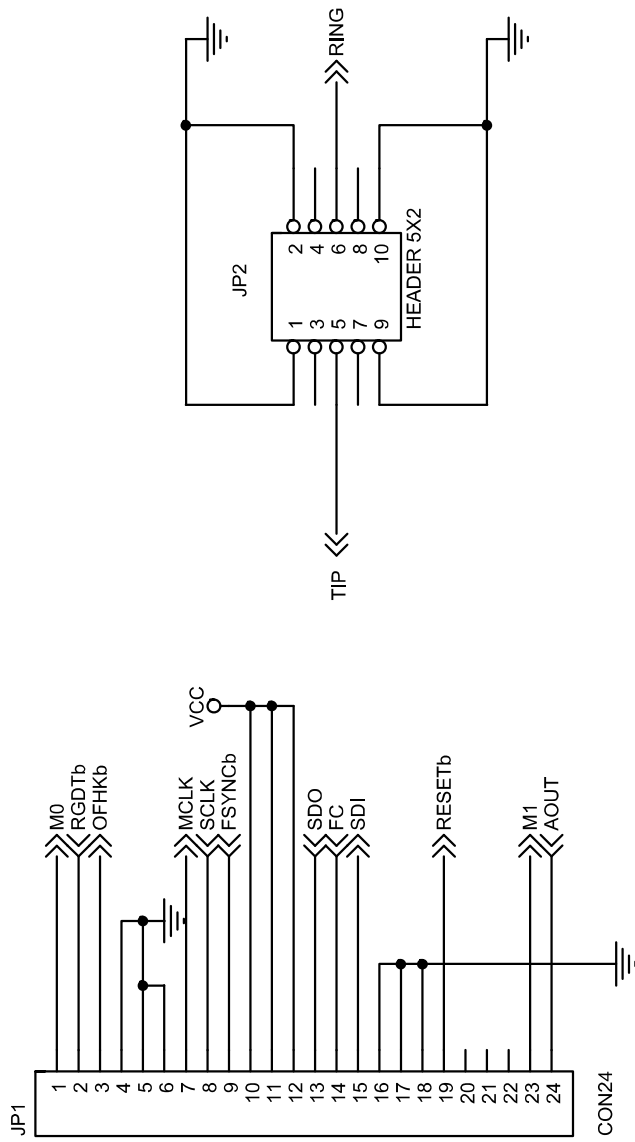

Figure 3. Si3034/35/44DC-EVB Schematic (1 of 2)

- Note 1: This design targets two basic builders:
 - An FCC Class 1ATE* using the Si3035 chipset.
 - A worldwide design using the Si3044 chipset.
- Note 2: R12, R13 and C14 are only required if complex AC termination is used (ACT=1).
- Note 3: See "Ringer Impedance" section for optional Czech Republic support.
- Note 4: See "Billing Tone Detection" section for optional billing tone filter (Germany, Switzerland, South Africa).
- Note 5: See Appendix for applications requiring UL 1950 3rd edition compliance.
- Note 6: For Si3035 designs R29 is populated with a 0 ohm resistor and R30 is not installed. For Si3044 designs R29 is not installed and R30 is populated with a 0 ohm resistor.
- Note 7: R27 should be 10 ohms when using an Si3021 Rev. A or B. R27 should be 0 ohms when using an Si3021 Rev. C or later.



Footprint of JP1
Top View

Figure 4. Si3034/35/44DC-EVB Schematic (2 of 2)

Bill of Materials: Si3034-EVB Daughter Card

Quantity	Reference	Part
2	C4,C1	150 pF, 3 kV, $\pm 20\%$, 1812, , C1808X7R302-151MNE, Venkel
1	C3	0.22 uF, 25 V, $\pm 20\%$, 0805, , C0805X7R250-224MNE, Venkel
1	C5	0.1 uF, 50 V, $\pm 20\%$, Case A, , TA050TCM104-MAL, Venkel
3	C6,C10,C16	0.1 uF, 16 V, $\pm 10\%$, 0603, , C0603X7R160-104KNE, Venkel
2	C7,C8	560 pF, 250 V, $\pm 10\%$, 0805, , C0805X7R251-561KNE, Venkel
1	C9	10 nF, 250 V, $\pm 20\%$, 0805, , C0805X7R251-103KNE, Venkel
4	R4,C11,R21,C30	NI, , , 0603, , ,
1	C12	0.22 uF, 35 V, $\pm 10\%$, Case A, , TA035TCM224-KAL, Venkel
1	C13	0.47 uF, 25 V, $\pm 10\%$, 0805, , C0805X7R250-474KNE, Venkel
1	C14	0.68 uF, 16 V, $\pm 10\%$, 1206, , 1206YC684KATMA, AVX
2	C18,C19	3.9 nF, 16 V, $\pm 10\%$, 0603, , C0603X7R160-392KNE, Venkel
1	C20	0.01 uF, 16 V, $\pm 20\%$, 0603, , C0603X7R160-103KNE, Venkel
1	C22	1800 pF, 50 V, $\pm 10\%$, 0603, , C0603X7R500-182KNE, Venkel
1	C23	NI, , , Case A, , ,
2	C24,C25	1000 pF, 3 kV, $\pm 10\%$, 1812, , C1808X7R302-102KNE, Venkel
4	R22,R23,C28,C29	NI, , , 0805, , ,
2	D1,D2	Dual Diode, 225 mA, 300 V, SOT-23, , CMPD2004S, Central Semiconductor
2	D3,D4	BAV99, 300 mA, 100 V, SOT-23, , BAV99, Diodes Inc.
2	FB1,FB2	Ferrite Bead, , , 1206, , BLM31A601S, Murata
1	JP1	CON24, , , 8x3 100 mil, , SSW-108-01-T-T,
1	JP2	HEADER 5X2, , , 5x2 100 mil, , SSW-105-01-T-D,
2	L2,L1	330 uH, 150 mA, , Thru Hole, , EL0607-331J, TDK
2	Q3,Q1	NPN, 300 V, , SOT-23, , MMBTA42LT1, Motorola
1	Q2	PNP, 300 V, , SOT-23, , MMBTA92LT1, Motorola
1	Q4	NPN, 80 V, , SOT-223, , BCP56T1, Motorola
1	RV1	SiDactor, 275 V, 100 A, SOD 6, , P3100SB, Teccor
1	RV2	NI, , , Thru-Hole, , ,
1	R1	NI, , , 2010, , ,
1	R2	402, 1/8 W, $\pm 1\%$, 1206, , CR1206-8W-4020FT, Venkel
1	R3	NI, , , 0805, , , Venkel
1	R5	36 K, 1/16 W, $\pm 5\%$, 0603, , CR0603-16W-363JT, Venkel
1	R6	120 K, 1/16 W, $\pm 5\%$, 0603, , CR0603-16W-124JT, Venkel
6	R7,R8,R15,R16,R17,R19	4.87 K, 1/4 W, $\pm 1\%$, 1206, , CR1206-4W-4871FT, Venkel
2	R10,R9	56 K, 1/10 W, $\pm 5\%$, 0805, , CR0805-10W-563JT, Venkel
1	R11	10 K, 1/10 W, $\pm 1\%$, 0603, , CR0603-16W-1002FT, Venkel
1	R12	78.7, 1/16 W, $\pm 1\%$, 0603, , CR0603-16W-78R7FT, Venkel
1	R13	215, 1/16 W, $\pm 1\%$, 0603, , CR0603-16W-2150FT, Venkel
1	R18	2.2 K, 1/10 W, $\pm 5\%$, 0805, , CR0805-10W-222JT, Venkel
1	R24	150, 1/10 W, $\pm 5\%$, 0603, , CR0603-10W-150JT, Venkel
2	R25,R26	NI, , , 0805, , ,
2	R28,R27	10, 1/10 W, $\pm 5\%$, RC05, , CR0805-10W-100JT, Venkel
1	R29	NI, , , 0603, , ,
1	R30	0, 1/10 W, $\pm 5\%$, 0603, , CR0603-10W-000JT, Venkel
1	U1	Si3021, , , 16SOIC, , Si3021-KS Rev. C, Silicon Labs
1	U2	Si301x, , , 16SOIC, , Si3014-KS Rev. C, Silicon Labs
1	Z1	Zener Diode, 43 V, , SOD-80, , ZMM43, General Semi
2	Z4,Z5	Zener Diode, 5.6 V, 500 mW, SOD123, , MMSZ5232B, Diodes Inc.

Si30xxSSI-EVB

Bill of Materials: Si3035-EVB Daughter Card

Quantity	Reference	Part
2	C4,C1	150 pF, 3 kV, ±20%, 1812, , C1808X7R302-151MNE, Venkel
1	C3	0.22 uF, 25 V, ±20%, 0805, , C0805X7R250-224MNE, Venkel
1	C5	1.0 uF, 16 V, ±20%, Case A, , TA016TCM105-MAL, Venkel
3	C6,C10,C16	0.1 uF, 16 V, ±10%, 0603, , C0603X7R160-104KNE, Venkel
6	R3,C7,C8,C13,R25,R26	NI, , , 0805, , ,
3	C9,C28,C29	15 nF, 250 V, ±20%, 0805, , C0805X7R251-153KNE, Venkel
1	C11	39 nF, 16 V, ±10%, 0603, , C0603X7R160-393KNE, Venkel
1	C12	NI, , , Case A, , ,
7	R7,R8,C14,R15,R16,R17, R19	NI, , , 1206, , ,
9	R12,R13,C18,C19,C20,C22, R24,R30,C30	NI, , , 0603, , ,
1	C23	NI, 35V, ±10%, Case A, , TA035TCM105-KAL, Venkel
2	C24,C25	1000 pF, 3 kV, ±10%, 1812, , C1808X7R302-102KNE, Venkel
2	D1,D2	Dual Diode, 225 mA, 300 V, SOT-23, , CMPD2004S, Central Semiconductor
2	D3,D4	BAV99, 300 mA, 100 V, SOT-23, , BAV99, Diodes Inc.
2	FB1,FB2	Ferrite Bead, , , 1206, , BLM31A601S, MuRata
1	JP1	CON24, , , 8x3 100 mil, , SSW-108-01-T-T,
1	JP2	HEADER 5X2, , , 5x2 100 mil, , SSW-105-01-T-D,
2	L2,L1	0 ohm,, , Thru Hole, , Wire Jumper
2	Q3,Q1	NPN, 300 V, , SOT-23, , MMBTA42LT1, Motorola
1	Q2	PNP, 300 V, , SOT-23, , MMBTA92LT1, Motorola
1	Q4	NI, , , SOT-223, , ,
1	RV1	SiDactor, 275 V, 100 A, SOD 6, , P3100SB, Teccor
1	RV2	MOV, 240 V, 1250 A, Thru-Hole, , ERZ-V07D241, Panasonic
1	R1	51, 1/2 W, ±5%, 2010, , C2010-2W-510JT, Venkel
1	R2	15, 1/4 W, ±5%, 1206, , CR1206-4W-150JT, Venkel
2	R4,R21	301, 1/16 W, ±1%, 0603, , CR0603-16W-3010FT, Venkel
2	R6,R5	36 K, 1/16 W, ±5%, 0603, , CR0603-16W-363JT, Venkel
2	R10,R9	2 K, 1/10 W, ±5%, 0805, , CR0805-10W-202JT, Venkel
1	R11	NI, 16 V, ±10%, 0603, , C0603X7R160-272KNE, Venkel
1	R18	300, 1/10 W, ±5%, 0805, , CR0805-10W-301JT, Venkel
2	R23,R22	20 K, 1/10 W, ±5%, 0805, , CR0805-10W-203JT, Venkel
2	R28,R27	10, 1/10 W, ±5%, RC05, , CR0805-10W-100JT, Venkel
1	R29	0, 1/10 W, ±5%, 0603, , CR0603-10W-000JT, Venkel
1	U1	Si3021, , , 16SOIC, , Si3021-KS Rev. C, Silicon Labs
1	U2	Si3012/5, , , 16SOIC, , Si3012-KS Rev. G, Silicon Labs
1	Z1	Zener Diode, 18 V, , SOD-80, , ZMM18, General Semi
2	Z4,Z5	Zener Diode, 5.6 V, 500 mW, SOD123, , MMSZ5232B, General Semi

Bill of Materials: Si3044-EVB Daughter Card

Quantity	Reference	Part
2	C4,C1	150 pF, 3 kV, $\pm 20\%$, 1812, , C1808X7R302-151MNE, Venkel
1	C3	0.22 uF, 25 V, $\pm 20\%$, 0805, , C0805X7R250-224MNE, Venkel
1	C5	0.1 uF, 50 V, $\pm 20\%$, Case A, , TA050TCM104-MAL, Venkel
3	C6,C10,C16	0.1 uF, 16 V, $\pm 10\%$, 0603, , C0603X7R160-104KNE, Venkel
2	C7,C8	560 pF, 250 V, $\pm 10\%$, 0805, , C0805X7R251-561KNE, Venkel
1	C9	10 nF, 250 V, $\pm 20\%$, 0805, , C0805X7R251-103KNE, Venkel
4	R4,C11,R21,C30	NI, , , 0603, , ,
1	C12	1.0 uF, 35 V, $\pm 10\%$, Case A, , TA035TCM105-KAL, Venkel
1	C13	0.22 uF, 25 V, $\pm 10\%$, 0805, , C0805X7R250-224KNE, Venkel
1	C14	0.68 uF, 16 V, $\pm 10\%$, 1206, , 1206YC684KATMA, AVX
2	C18,C19	3.9 nF, 16 V, $\pm 10\%$, 0603, , C0603X7R160-392KNE, Venkel
1	C20	0.01 uF, 16 V, $\pm 20\%$, 0603, , C0603X7R160-103KNE, Venkel
1	C22	1800 pF, 50 V, $\pm 10\%$, 0603, , C0603X7R500-182KNE, Venkel
1	C23	NI, , , Case A, , ,
2	C24,C25	1000 pF, 3 kV, $\pm 10\%$, 1812, , C1808X7R302-102KNE, Venkel
4	R22,R23,C28,C29	NI, , , 0805, , ,
2	D1,D2	Dual Diode, 225 mA, 300 V, SOT-23, , CMPD2004S, Central Semiconductor
2	D3,D4	BAV99, 300 mA, 100 V, SOT-23, , BAV99, Diodes Inc.
2	FB1,FB2	Ferrite Bead, , , 1206, , BLM31A601S, Murata
1	JP1	CON24, , , 8x3 100 mil, , SSW-108-01-T-T,
1	JP2	HEADER 5X2, , , 5x2 100 mil, , SSW-105-01-T-D,
2	L2,L1	330 uH, 150 mA, , Thru Hole, , EL0607-331J, TDK
2	Q3,Q1	NPN, 300 V, , SOT-23, , MMBTA42LT1, Motorola
1	Q2	PNP, 300 V, , SOT-23, , MMBTA92LT1, Motorola
1	Q4	NPN, 80 V, , SOT-223, , BCP56T1, Motorola
1	RV1	SiDactor, 275 V, 100 A, SOD 6, , P3100SB, Teccor
1	RV2	NI, , , Thru-Hole, , ,
1	R1	NI, , , 2010, , ,
1	R2	402, 1/8 W, $\pm 1\%$, 1206, , CR1206-8W-4020FT, Venkel
1	R3	NI, , , 0805, , , Venkel
1	R5	100 K, 1/16 W, $\pm 1\%$, 0603, , CR0603-16W-104FT, Venkel
1	R6	120 K, 1/16 W, $\pm 5\%$, 0603, , CR0603-16W-124JT, Venkel
6	R7,R8,R15,R16,R17,R19	5.36 K, 1/4 W, $\pm 1\%$, 1206, , CR1206-4W-5361FT, Venkel
2	R10,R9	56 K, 1/10 W, $\pm 5\%$, 0805, , CR0805-10W-563JT, Venkel
1	R11	9.31 K, 1/10 W, $\pm 1\%$, 0603, , CR0603-16W-9311FT, Venkel
1	R12	78.7, 1/16 W, $\pm 1\%$, 0603, , CR0603-16W-78R7FT, Venkel
1	R13	215, 1/16 W, $\pm 1\%$, 0603, , CR0603-16W-2150FT, Venkel
1	R18	2.2 K, 1/10 W, $\pm 5\%$, 0805, , CR0805-10W-222JT, Venkel
1	R24	150, 1/10 W, $\pm 5\%$, 0603, , CR0603-10W-150JT, Venkel
2	R25,R26	10 M, 1/10 W, $\pm 5\%$, 0805, , CR0805-10W-106JT, Venkel
2	R28,R27	10, 1/10 W, $\pm 5\%$, RC05, , CR0805-10W-100JT, Venkel
1	R29	NI, , , 0603, , ,
1	R30	0, 1/10 W, $\pm 5\%$, 0603, , CR0603-10W-000JT, Venkel
1	U1	Si3021, , , 16SOIC, , Si3021-KS Rev. C, Silicon Labs
1	U2	Si301x, , , 16SOIC, , Si3015-KS Rev. D, Silicon Labs
1	Z1	Zener Diode, 43 V, , SOD-80, , ZMM43, General Semi
2	Z4,Z5	Zener Diode, 5.6 V, 500 mW, SOD123, , MMSZ5232B, Diodes Inc.

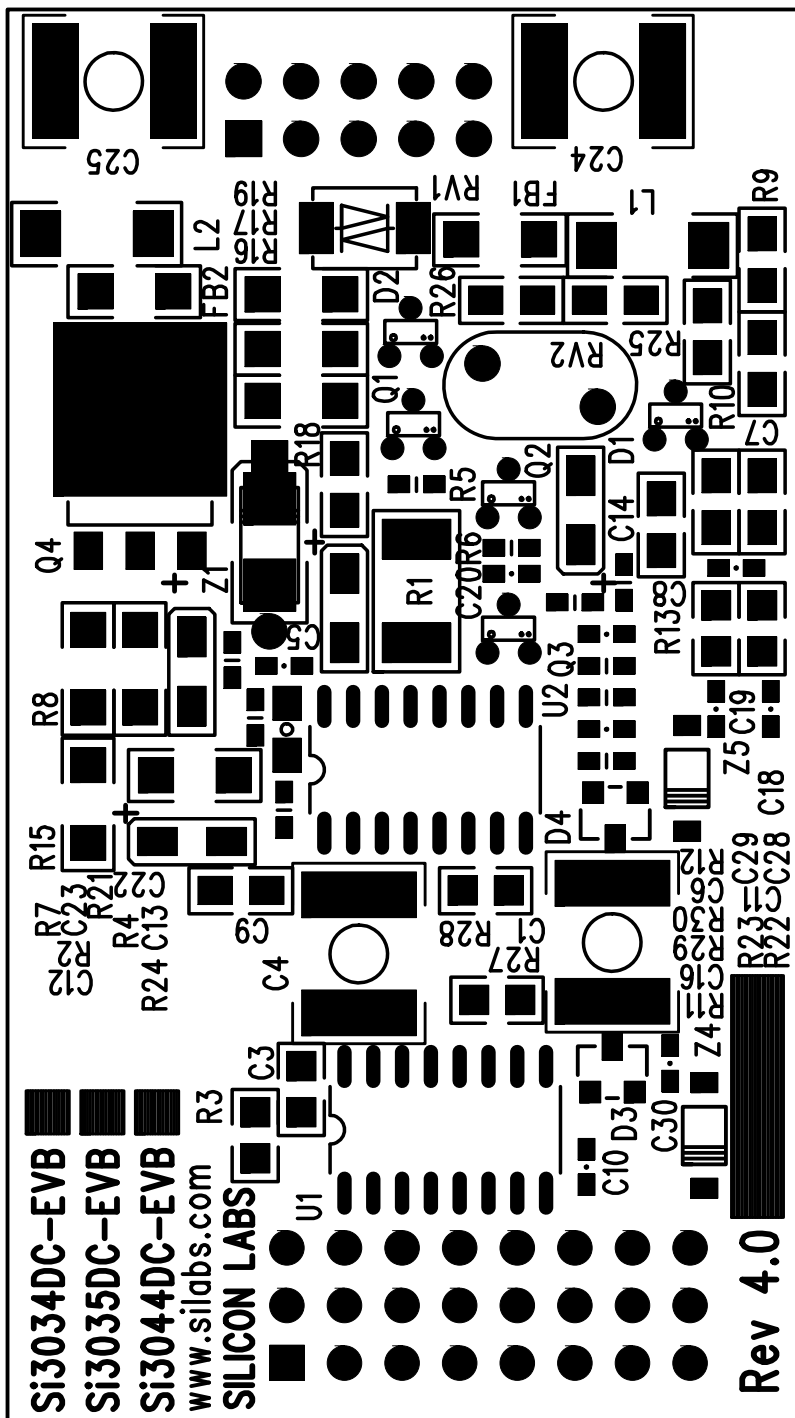

Figure 5. Si3034/35/44DC-EVB Silkscreen

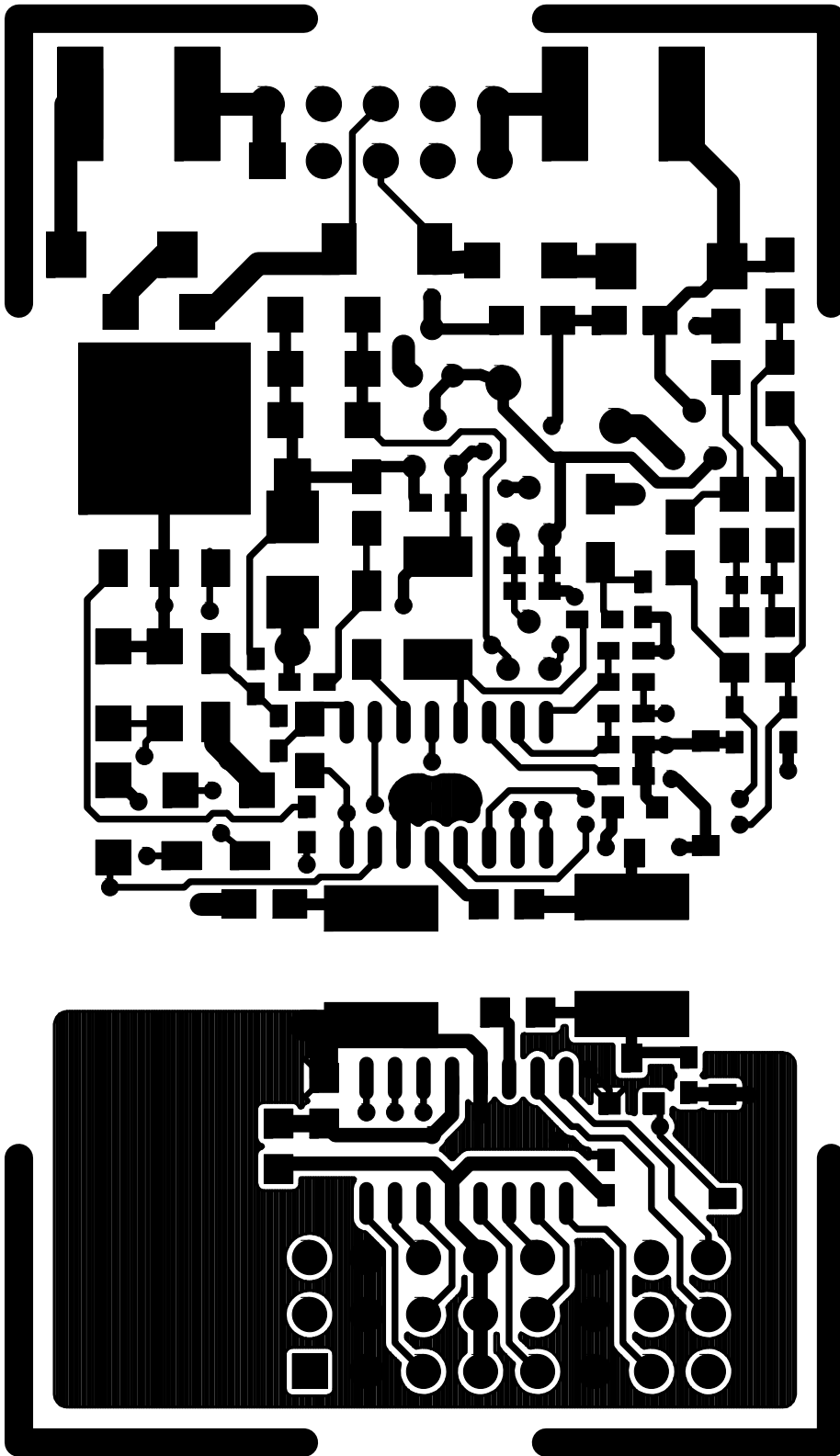

Figure 6. Si3034/35/44DC-EVB Component Side

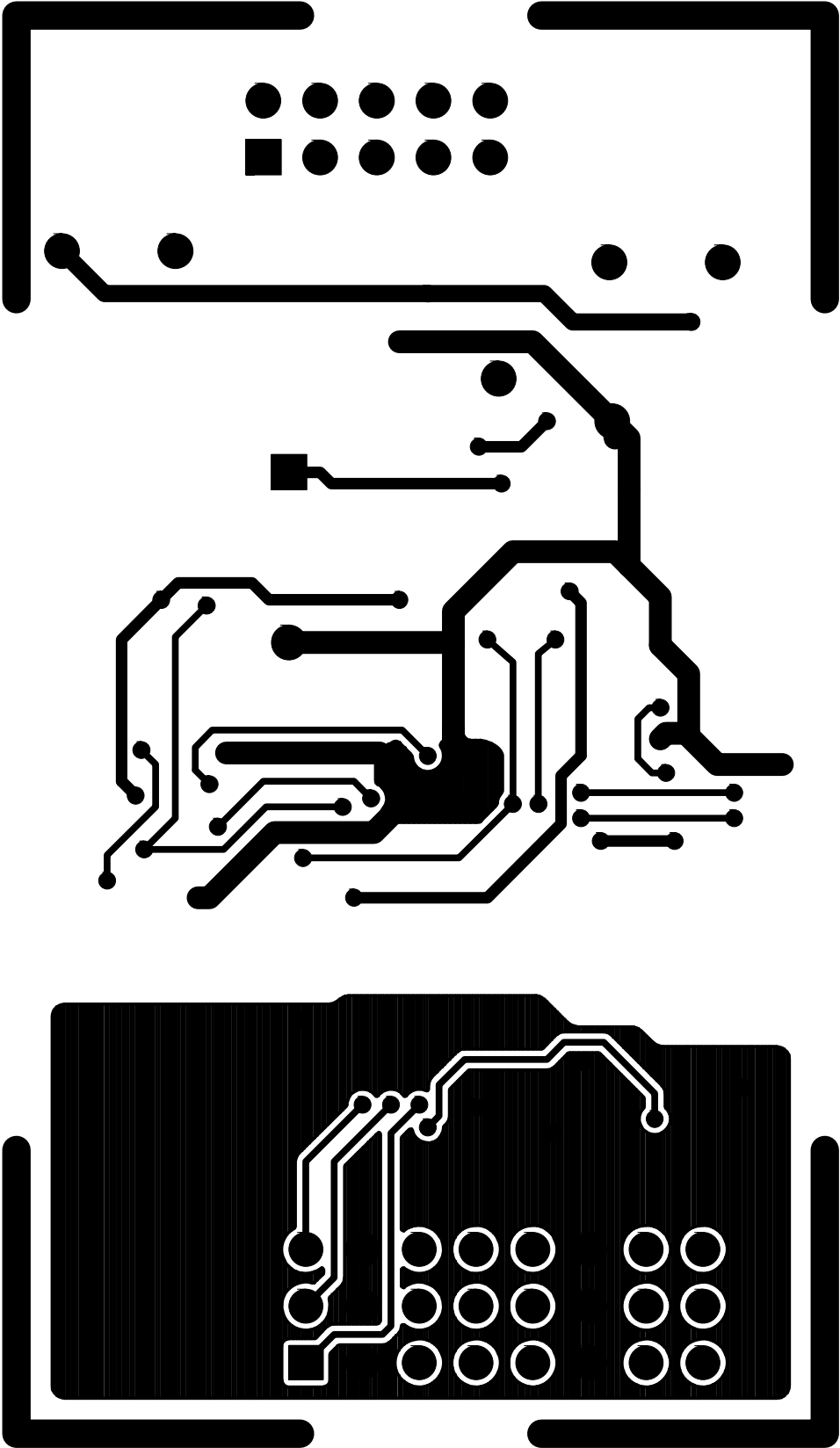

Figure 7. Si3034/35/44DC-EVB Solder Side

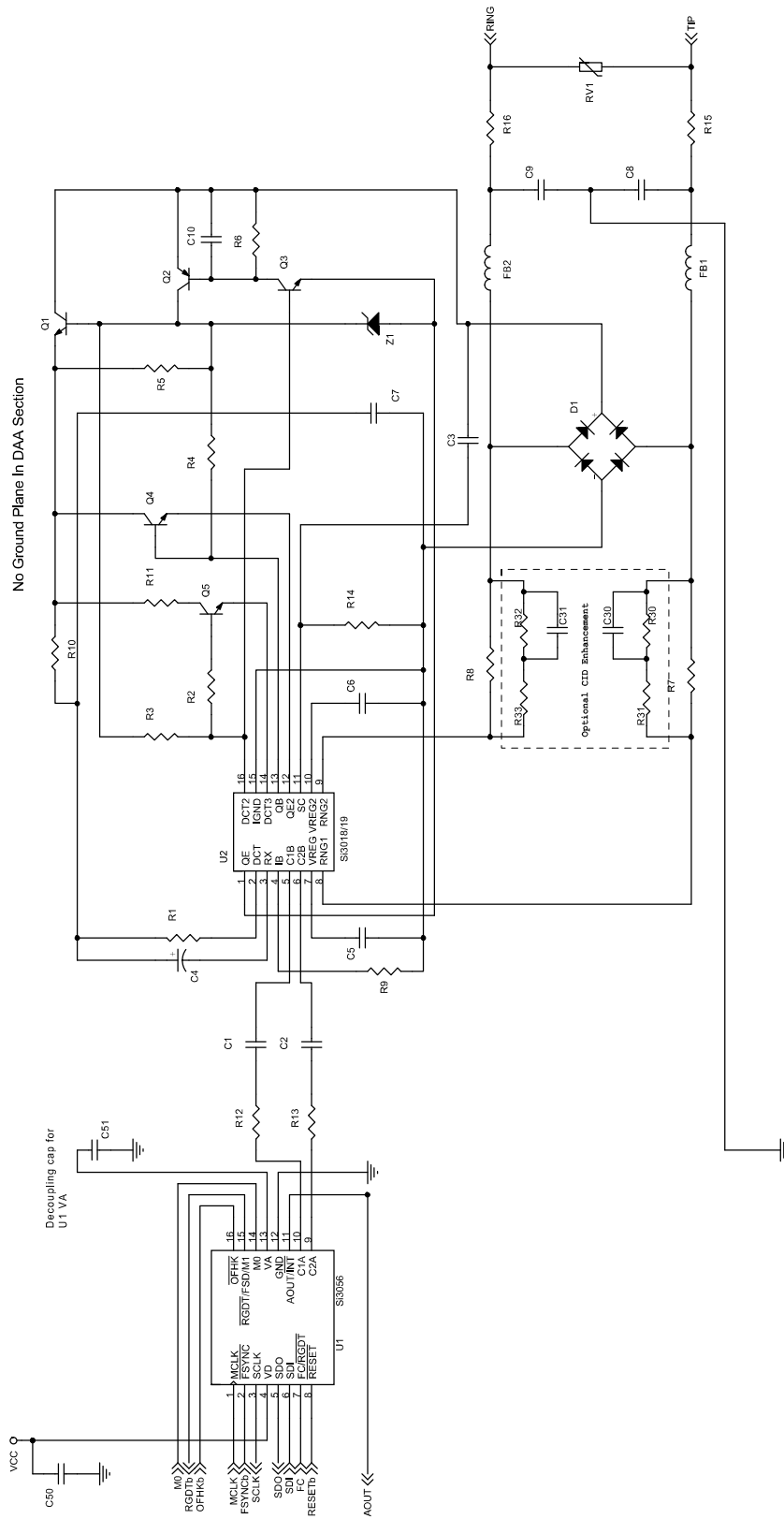

Figure 8. Si3056DC-EVB Schematic (1 of 2)

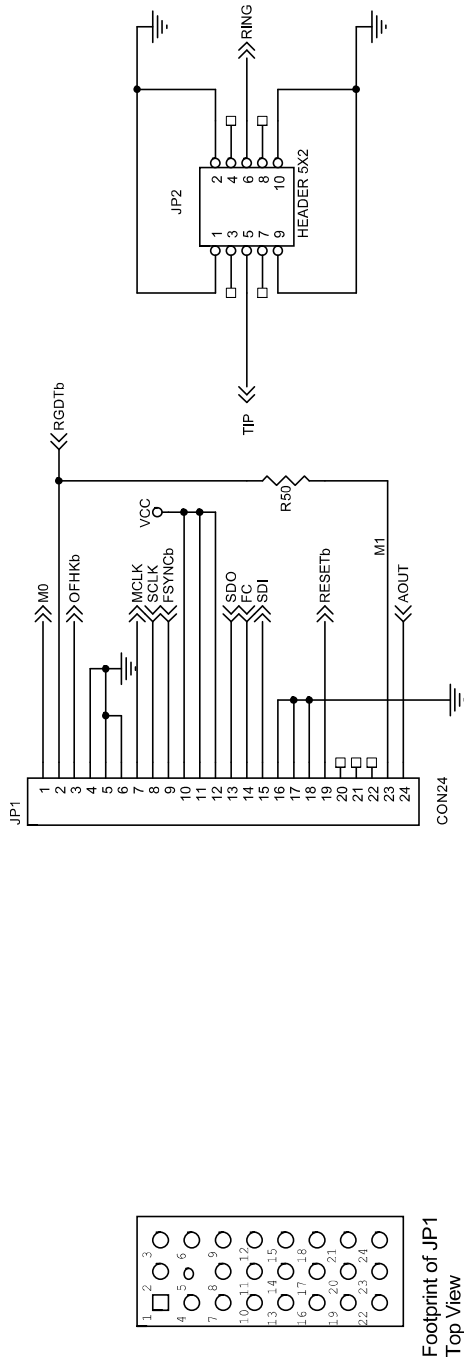

Figure 9. Si3056DC-EVB Schematic (2 of 2)

Si3056DC-EVB Bill of Materials

Reference	Value	Tolerance	Rating	Part Number	Manufacturer
C2,C1	33 pF	±20%	Y2	ECCAVS330KGS	Panasonic
C3	10 nF	±20%	250 V	C0805X7R251-103MNE	Venkel
C4	1.0 uF	±20%	50 V	ECE-V1HS010SR	Panasonic
C6,C5	0.1 uF	±20%	16 V	C0603X7R160-104MNE	Venkel
C7	2.7 nF	±20%	50 V	C0603X7R500-272MNE	Venkel
C9,C8	680 pF	±10%	Y2	ECKATS681KBS	Panasonic
C10	0.01 uF	±20%	16 V	C0603X7R160-103MNE	Venkel
C30,C31	DNP 120pF	±20%	250 V	C0805X7R251-121MNE	Venkel
C51,C50	0.1 uF	±20%	16 V	C0805X7R160-104MNE	Venkel
D1	HD04		400 V	HD04-T	Diodes, Inc.
FB1,FB2	Ferrite Bead			BLM21A601S	MuRata
JP1	CON24			SSW-108-02-G-T	Samtec
JP2	HEADER 5X2			SSW-105-01-T-D	Samtec
Q3,Q1	NPN		300 V	MMBTA42LT1	Motorola
Q2	PNP		300 V	MMBTA92LT1	Motorola
Q4,Q5	NPN		80 V	MMBTA06LT1	Motorola
RV1	SiDactor	100 A	275 V	P3100SB	Teccor
R1	1.07 K	±1%	1/2 W	CR1210-2W-1071FT	Venkel
R2	150	±5%	1/16 W	CR0402-16W-150JT	Venkel
R3	3.65 K	±1%	1/2 W	CR1210-2W-3651FT	Venkel
R4	2.49 K	±1%	1/2 W	CR1210-2W-2491FT	Venkel
R6,R5	100 K	±5%	1/16 W	CR0402-16W-104JT	Venkel
R8,R7	20 M	±1%	1/8 W	CR0805-8W-2005FT	Venkel
R9	1 M	±1%	1/16 W	CR0402-16W-1004FT	Venkel
R10	536	±1%	1/4 W	CR1206-4W-5360FT	Venkel
R11	73.2	±1%	1/2 W	CR1210-2W-73R2FT	Venkel
R12,R13,R14	0	±1%	1/16 W	CR0603-16W-000F	Venkel
R16,R15	0	±1%	1/16 W	CR0805-16W-000F	Venkel
R32,R30	DNP 15M	±5%	1/8 W	CR0805-8W-156JT	Venkel
R31,R33	DNP 5.1M	±5%	1/8 W	CR0805-8W-515JT	Venkel
R50	47 K	±5%	1/16 W	CR0603-16W-473JT	Venkel
U1	Si3056			Si3056-KS Rev C	Silicon Labs
U2	Si3018/19			Si3018-KS Rev C	Silicon Labs
Z1	43 V		1/2 W	ZMM43	General Semi

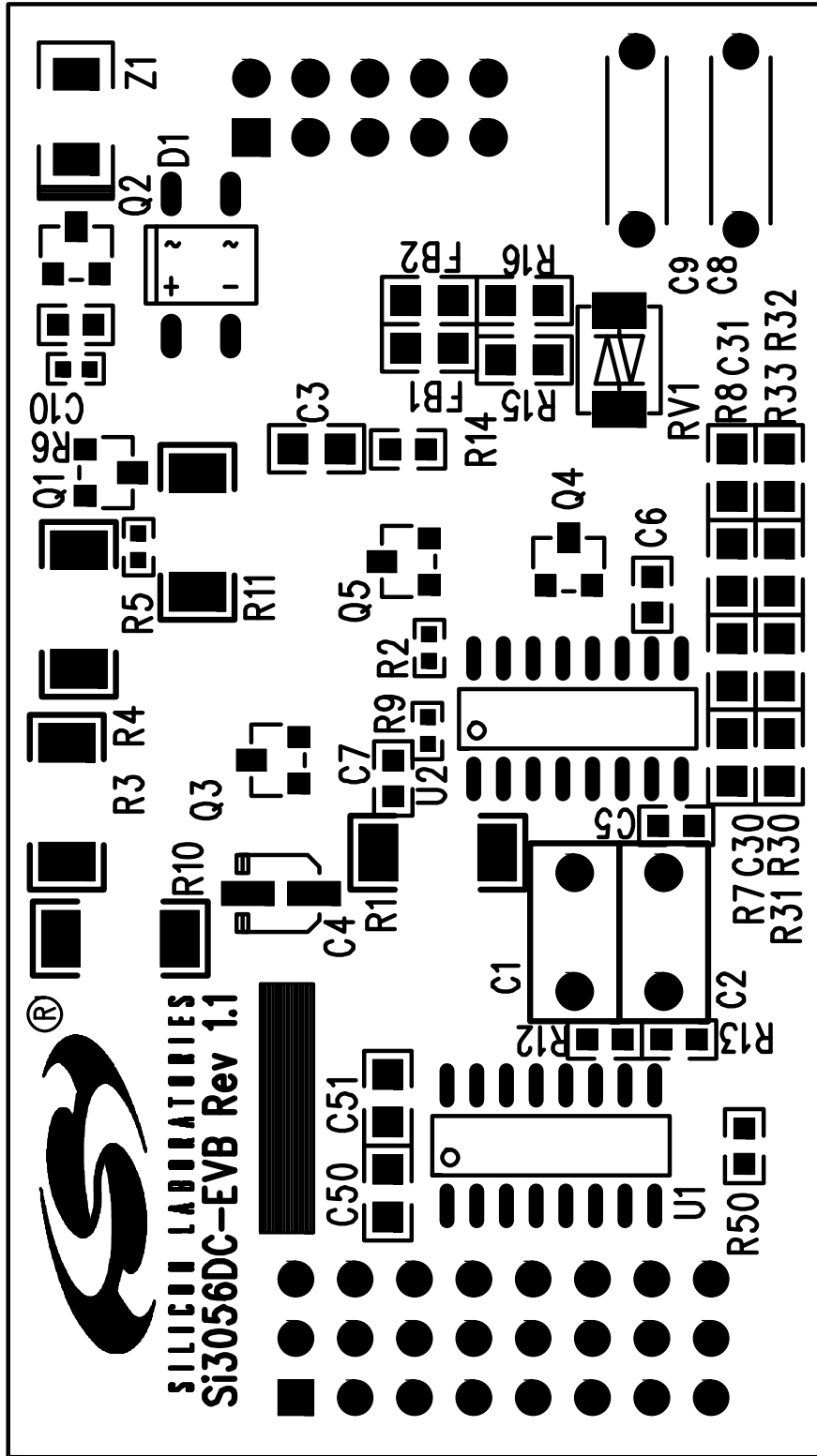

Figure 10. Si3056DC-EVB Silkscreen

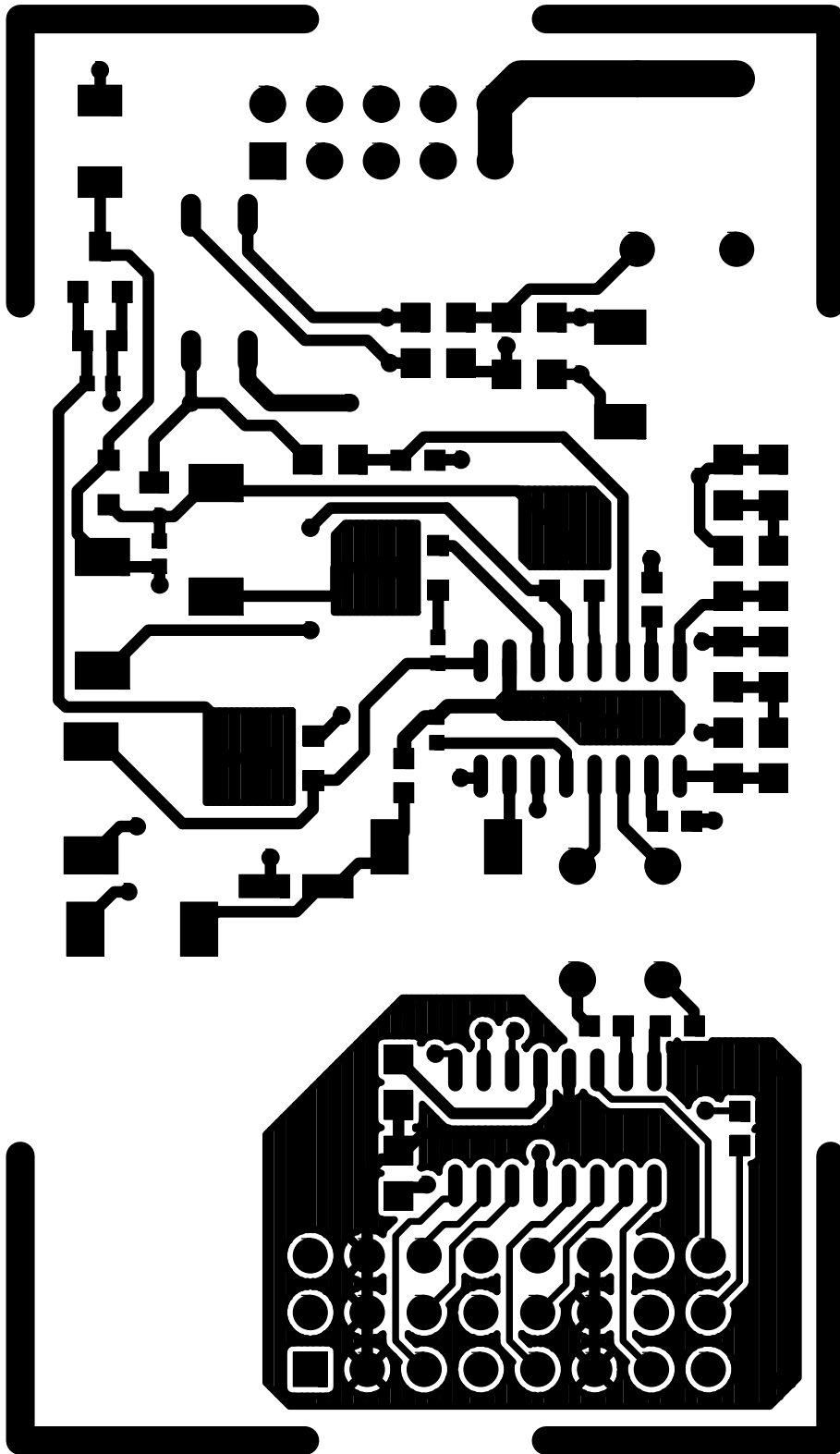

Figure 11. Si3056DC-EVB Component Side

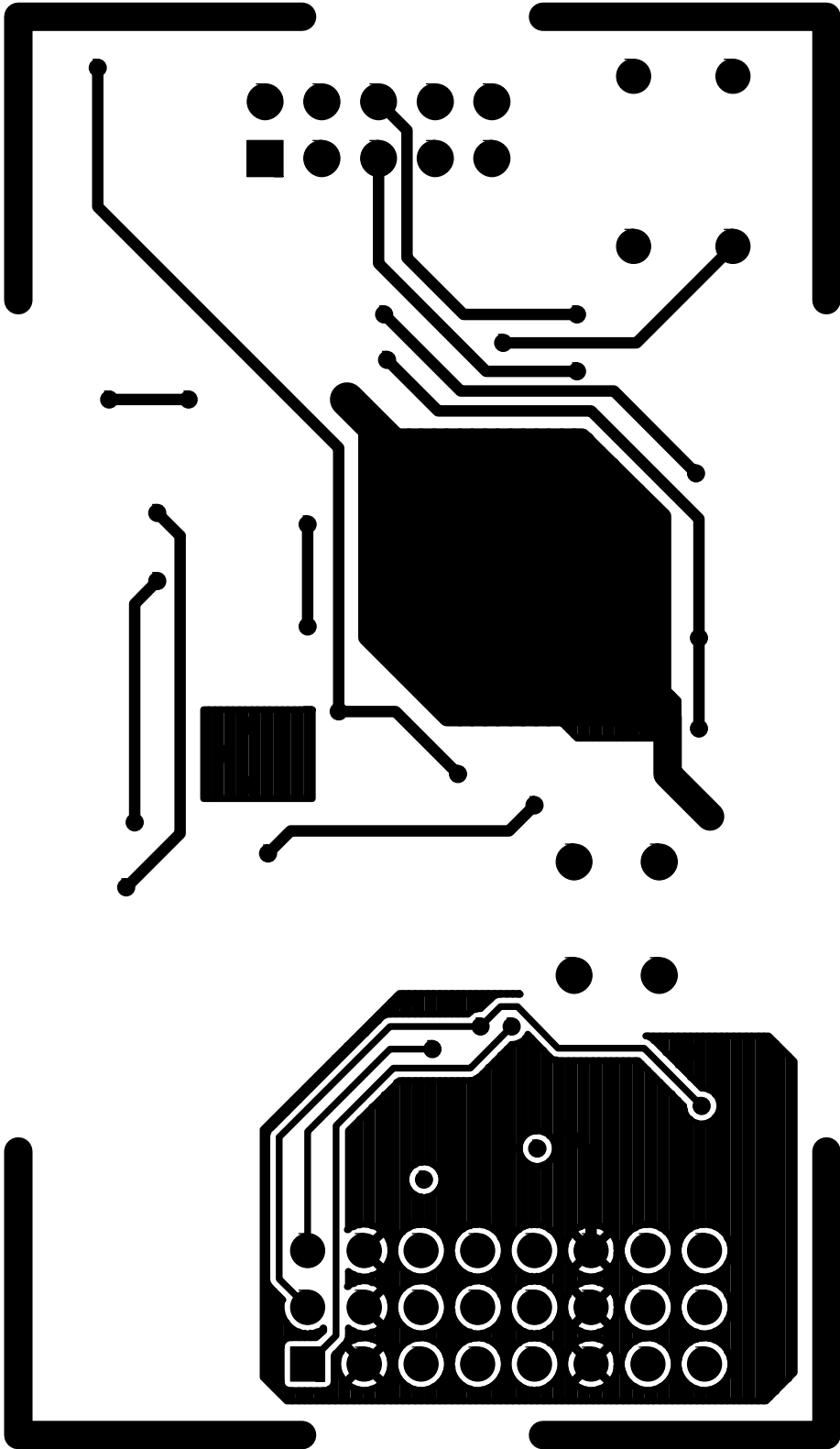

Figure 12. Si3056DC-EVB Solder Side

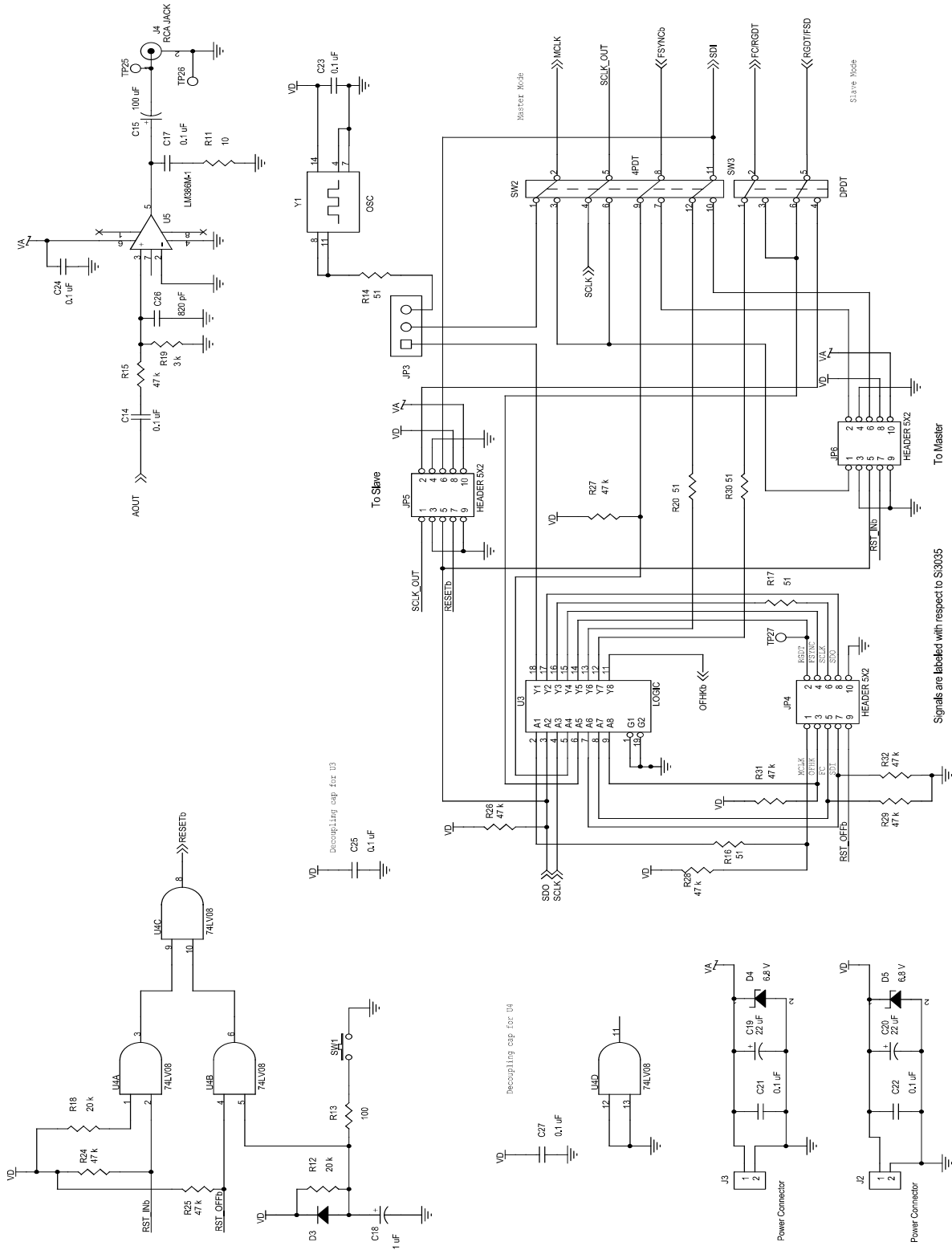
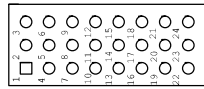
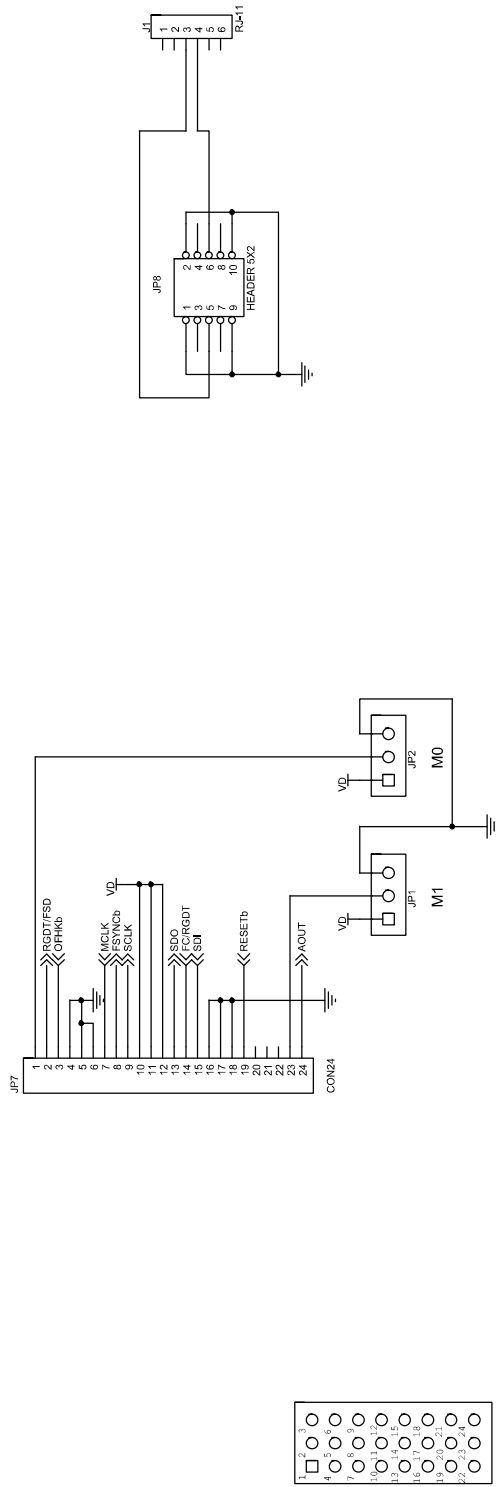

Figure 13. Si30xxSSI-EVB Schematic (1 of 2)



Footprint of JP7
Top View

Board Config.	SW2	SW3	M1	M0
Stand Alone	1	1	GNP	X
Master w/ Slaves	1	2	GNP	VD
Slave	2	2	VD	GNP

Figure 14. Si30xxSSI-EVB Schematic (2 of 2)

Si30xxSSI-EVB Component Values

Table 3. Si30xxSSI-EVB Bill of Materials

Component	Value	Supplier
C14,C17,C21,C22,C23, C24,C25,C27	0.1 μ F, 16 V, \pm 10%	Venkel
C15	100 μ F, 16 V, \pm 10%	Venkel
C18	1 μ F, 16 V, \pm 10%	Venkel
C19,C20	22 μ F, 16 V, \pm 10%	Venkel
C26	820 pF, 50 V, \pm 5%	Venkel
D3	DIODE, 400 mA, 75 V	Diodes, Inc.
D4,D5	6.8 V, 6.8 V	Diodes, Inc.
JP1,JP2,JP3	3x1 Header, 3x1 100 mil	Berg Electronics
JP4,JP8	HEADER 5x2, 5x2 100 mil	Samtec
JP5	HEADER 5x2, 10 pin thru-hole	Samtec
JP6	HEADER 5x2, 10 pin thru-hole	Samtec
JP7	CON24, 3x8 100 mil	Samtec
J1	RJ-11, thru-hole 6	Mouser
J2,J3	Power Connector, thru-hole 2	Mouser
J4	RCA JACK, thru-hole	Mouser
R11	10, 1/10 W, \pm 1%, 0805	NIC Components
R12,R18	20 k, 1/10 W, \pm 1%, 0805	NIC Components
R13	100, 1/4 W, \pm 1%, 1206	Rohm
R14,R16,R17,R20,R30	51, 1/10 W, \pm 5%, 0805	AVX
R15,R24,R25,R26,R27, R28,R29,R31,R32	47 k, 1/10 W, \pm 5%, 0805	NIC Components
R19	3 k, 1/10 W, \pm 5%, 0805	NIC Components
SW1	SW PUSHBUTTON, thru-hole 4	Mouser
SW2	4PDT, SMT12	Alcoswitch
SW3	DPDT, thru-hole 8	Alcoswitch
TP25	Test Point, thru-hole	Mouser
TP26	Test Point, thru-hole	Mouser
TP27	Test Point, thru-hole	Mouser
U3	LOGIC, 20-pin SOIC	Harris
U4	74LV08, SO14	Philips
U5	OP-AMP, M	National Semi
Y1	OSC, DIP14	

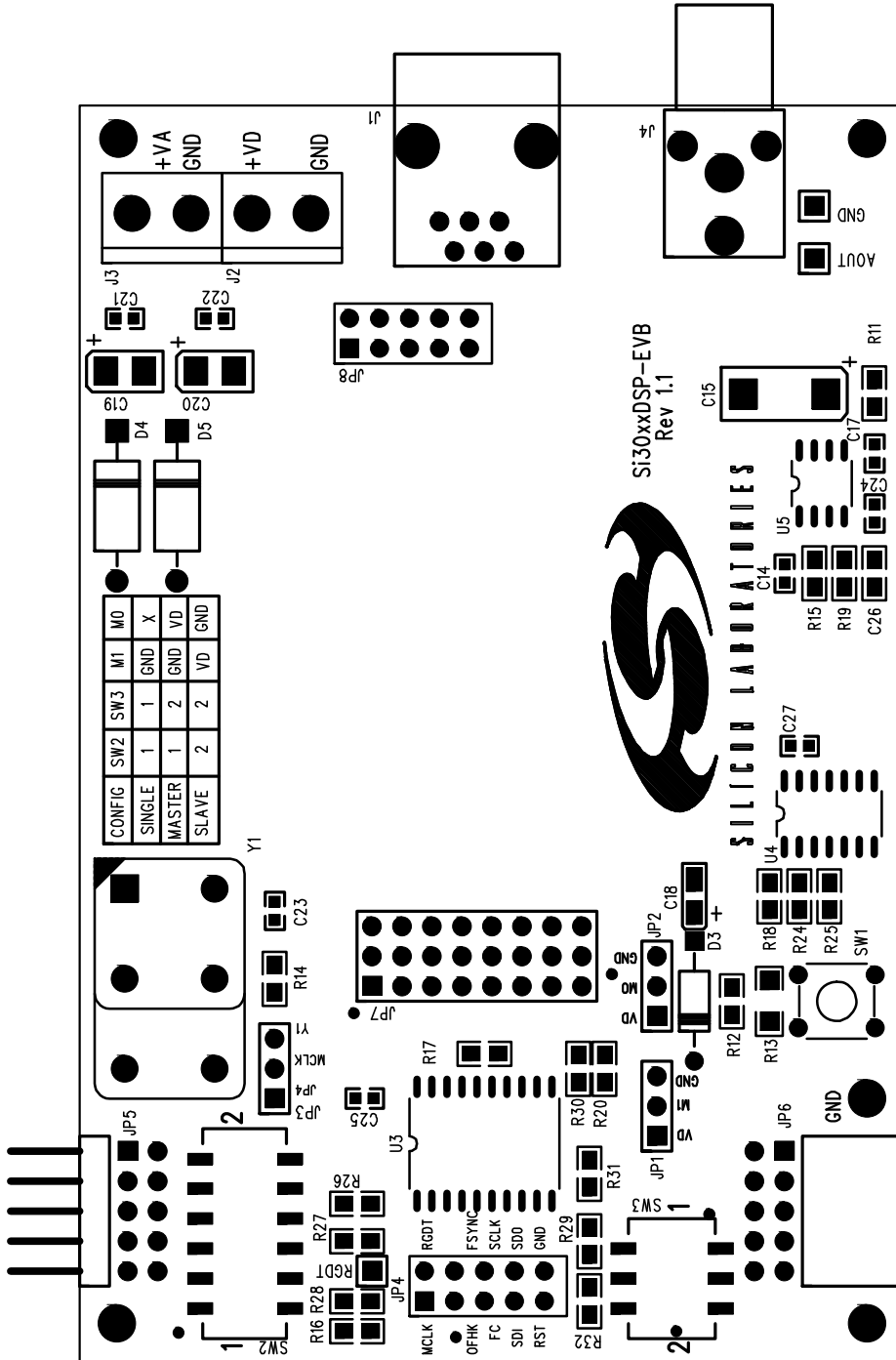

Figure 15. Si30xxSSI-EVB Silkscreen

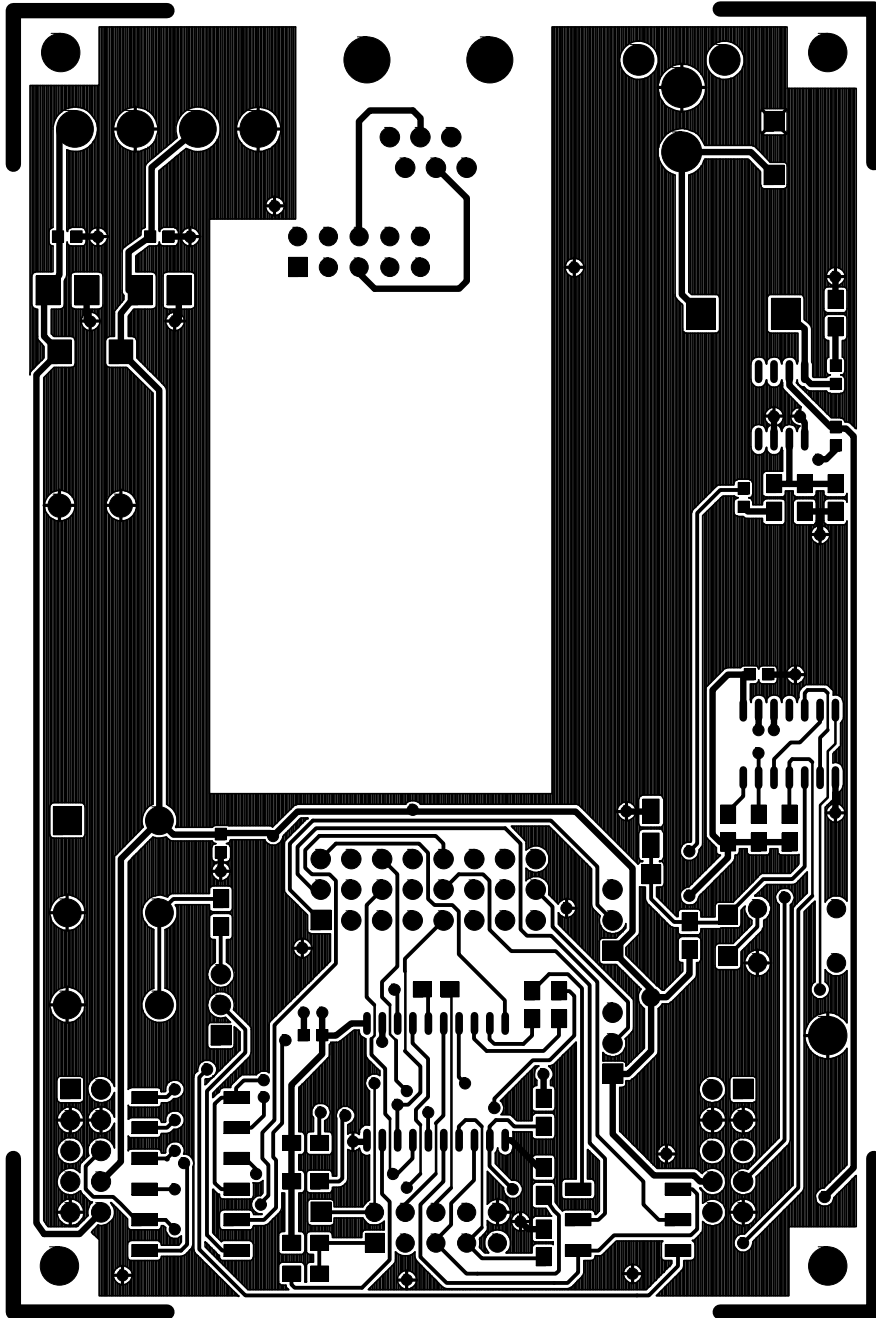

Figure 16. Si30xxSSI-EVB Component Side

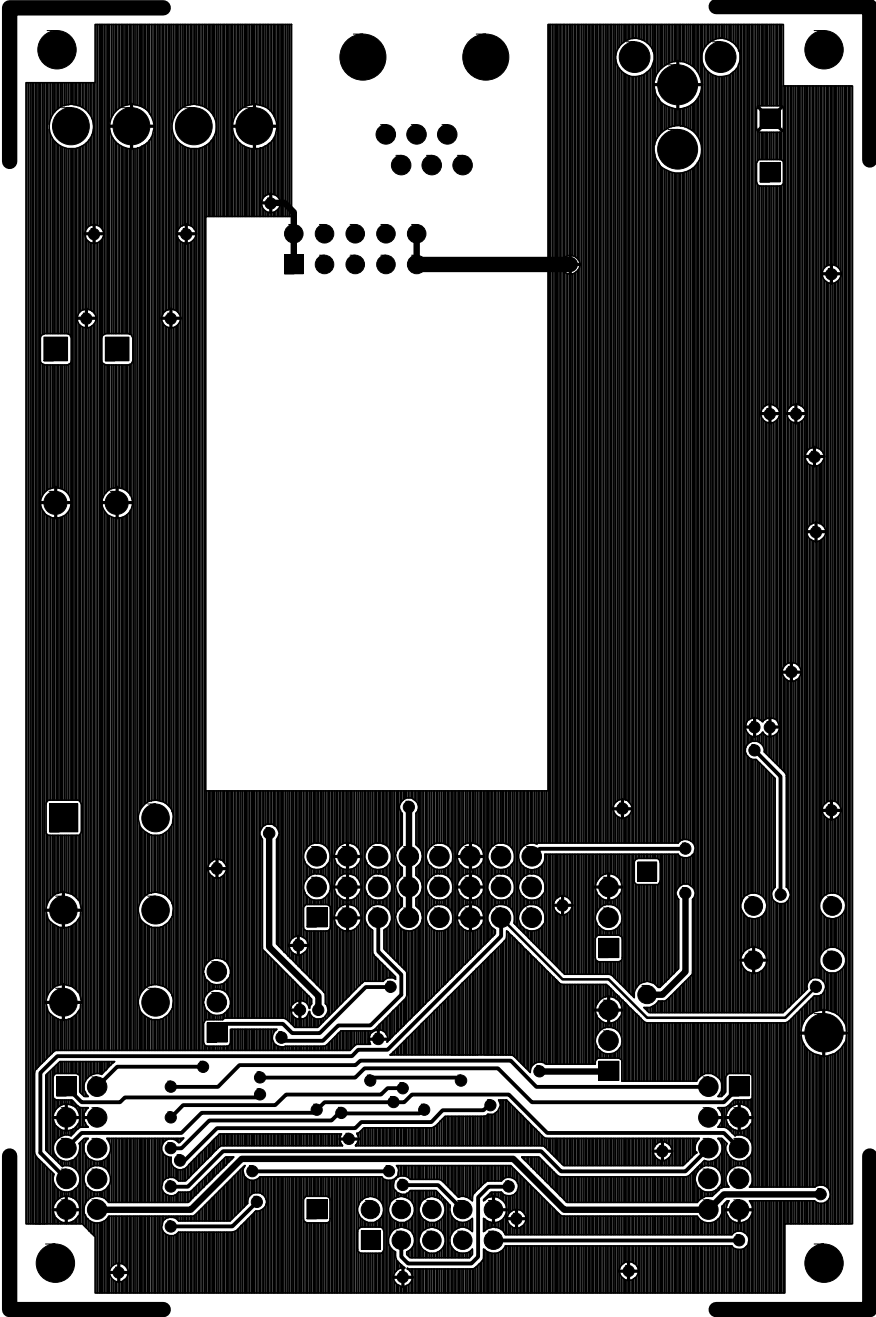
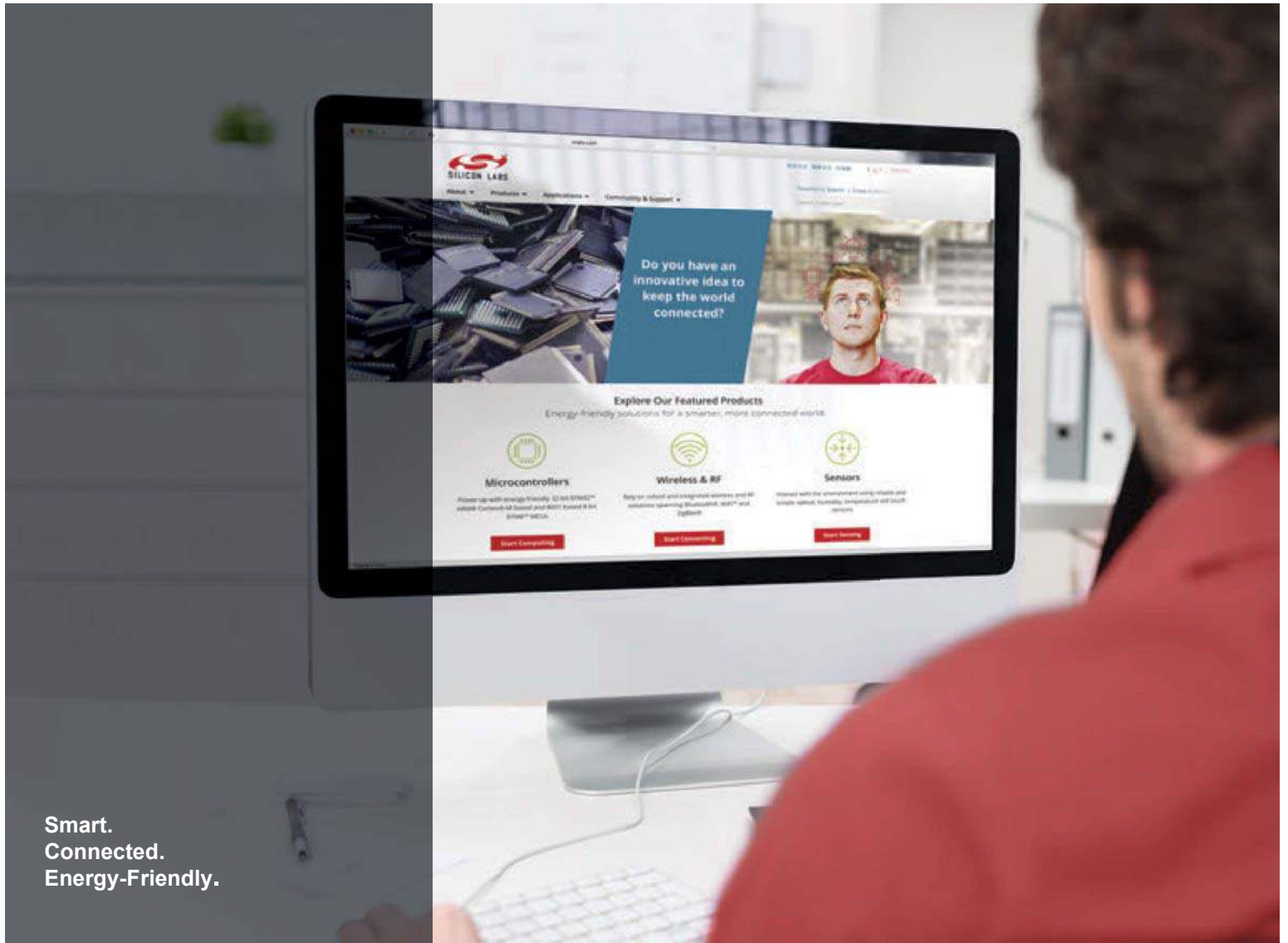

Figure 17. Si30xxSSI-EVB Solder Side

Document Change List

Revision 1.0 to Revision 1.1.

- Added BOMs for Si3034 and Si3044 daughter cards



Smart.
Connected.
Energy-Friendly.



Products
www.silabs.com/products

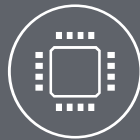

Quality
www.silabs.com/quality



Support and Community
community.silabs.com

Disclaimer
Silicon Laboratories intends to provide customers with the latest, accurate, and in-depth documentation of all peripherals and modules available for system and software implementers using or intending to use the Silicon Laboratories products. Characterization data, available modules and peripherals, memory sizes and memory addresses refer to each specific device, and "Typical" parameters provided can and do vary in different applications. Application examples described herein are for illustrative purposes only. Silicon Laboratories reserves the right to make changes without further notice and limitation to product information, specifications, and descriptions herein, and does not give warranties as to the accuracy or completeness of the included information. Silicon Laboratories shall have no liability for the consequences of use of the information supplied herein. This document does not imply or express copyright licenses granted hereunder to design or fabricate any integrated circuits. The products are not designed or authorized to be used within any Life Support System without the specific written consent of Silicon Laboratories. A "Life Support System" is any product or system intended to support or sustain life and/or health, which, if it fails, can be reasonably expected to result in significant personal injury or death. Silicon Laboratories products are not designed or authorized for military applications. Silicon Laboratories products shall under no circumstances be used in weapons of mass destruction including (but not limited to) nuclear, biological or chemical weapons, or missiles capable of delivering such weapons.

Trademark Information
Silicon Laboratories Inc.®, Silicon Laboratories®, Silicon Labs®, SiLabs® and the Silicon Labs logo®, Bluegiga®, Bluegiga Logo®, Clockbuilder®, CMEMS®, DSPLL®, EFM®, EFM32®, EFR®, Ember®, Energy Micro, Energy Micro logo and combinations thereof, "the world's most energy friendly microcontrollers", Ember®, EZLink®, EZRadio®, EZRadioPRO®, Gecko®, ISOModem®, Precision32®, ProSLIC®, Simplicity Studio®, SiPHY®, Telegesis, the Telegesis Logo®, USBXpress® and others are trademarks or registered trademarks of Silicon Laboratories Inc. ARM, CORTEX, Cortex-M3 and THUMB are trademarks or registered trademarks of ARM Holdings. Keil is a registered trademark of ARM Limited. All other products or brand names mentioned herein are trademarks of their respective holders.



Silicon Laboratories Inc.
400 West Cesar Chavez
Austin, TX 78701
USA

<http://www.silabs.com>