

MCU Cards

for **LV24-33A™** development system

Manual

All Mikroelektronika's development systems feature a large number of peripheral modules expanding microcontroller's range of application and making the process of program testing easier. In addition to these modules, it is also possible to use numerous additional modules linked to the development system through the I/O port connectors. Some of these additional modules can operate as stand-alone devices without being connected to the microcontroller.

Additional Board

 **MikroElektronika**

SOFTWARE AND HARDWARE SOLUTIONS FOR EMBEDDED WORLD ...making it simple

MCU Cards for LV24-33A Development System

The LV24-33A development system is supported by empty 18-, 20-, 28-, 44-, 64-, 80- and 100-pin MCU cards. Schematics provided herein show these MCU cards with soldered microcontrollers. Instead of microcontrollers used in these examples, you can choose and solder another ones. Prior to soldering, check which microcontrollers can be placed on the respective MCU card just to be sure that they are compatible.

Supported microcontrollers:

64-pin MCU cards *MCU Card 1* support the following microcontrollers: dsPIC33FJ64MC506-PT, dsPIC33FJ64MC706-PT, dsPIC33FJ128MC506-PT, dsPIC33FJ128MC706-PT, PIC24FJ64GA006-PT, PIC24FJ96GA006-PT and PIC24FJ128GA006-PT.

64-pin MCU cards *MCU Card 2* support the following microcontrollers: dsPIC33FJ64GP206-PT, dsPIC33FJ64GP306-PT, dsPIC33FJ64GP706-PT, dsPIC33FJ128GP206-PT, dsPIC33FJ128GP306-PT, dsPIC33FJ128GP706-PT, dsPIC33FJ256GP506-PT, PIC24HJ64GP206-PT, PIC24HJ64GP506-PT, PIC24HJ128GP206-PT, PIC24HJ128GP506-PT, PIC24HJ128GP306-PT and PIC24HJ256GP206-PT.

80-pin MCU cards *MCU Card 3* support the following microcontrollers: dsPIC33FJ64MC508-PT, dsPIC33FJ128MC708-PT, PIC24FJ64GA008-PT and PIC24FJ96GA008-PT

80-pin MCU cards *MCU Card 4* support the following microcontrollers: PIC24FJ128GA008-PT, dsPIC33FJ64GP708-PT and dsPIC33FJ128GP708-PT

100-pin MCU cards *MCU Card 5* support the following microcontrollers: dsPIC33FJ64MC510-PT, dsPIC33FJ64MC710-PT, dsPIC33FJ128MC510-PT, dsPIC33FJ128MC710-PT, dsPIC33FJ256MC510-PT, dsPIC33FJ256MC710-PT, PIC24FJ64GA010-PT, PIC24FJ96GA010-PT and PIC24FJ128GA010-PT

100-pin MCU cards *MCU Card 6* support the following microcontrollers: dsPIC33FJ64GP310-PT, dsPIC33FJ64GP710-PT, dsPIC33FJ128GP310-PT, dsPIC33FJ128GP710-PT, dsPIC33FJ256GP510-PT, dsPIC33FJ256GP710-PT, PIC24HJ64GP210-PT, PIC24HJ64GP510-PT, PIC24HJ128GP210-PT, PIC24HJ128GP510-PT, PIC24HJ128GP310-PT, PIC24HJ256GP210-PT and PIC24HJ256GP610-PT

100-pin MCU cards *MCU Card 7* support the following microcontrollers: dsPIC33FJ64MC510-PF, dsPIC33FJ64MC710-PF, dsPIC33FJ128MC510-PF, dsPIC33FJ128MC710-PF, dsPIC33FJ256MC510-PF, dsPIC33FJ256MC710-PF, PIC24FJ64GA010-PF and PIC24FJ96GA010-PF

100-pin MCU cards *MCU Card 8* support the following microcontrollers: PIC24FJ128GA010-PF, dsPIC33FJ64GP310-PF, dsPIC33FJ64GP710-PF, dsPIC33FJ128GP310-PF, dsPIC33FJ128GP710-PF, dsPIC33FJ256GP710-PF, PIC24HJ64GP210-PF, PIC24HJ64GP510-PF, PIC24HJ128GP210-PF, PIC24HJ128GP510-PF, PIC24HJ128GP310-PF, PIC24HJ256GP210-PF and PIC24HJ256GP610-PF

18-pin MCU cards *MCU Card 9* support the following microcontrollers: PIC24HJ12GP201-DIP18 and dsPIC33FJ12GP201-DIP18

20-pin MCU cards *MCU Card 10* support the following microcontroller: dsPIC33FJ12MC201-DIP20

28-pin MCU cards *MCU Card 11* support the following microcontrollers: PIC24HJ12GP202-DIP28, PIC24HJ32GP202-DIP28, PIC24FJ16GA002-DIP28, PIC24FJ32GA002-DIP28, PIC24FJ48GA002-DIP28, PIC24FJ64GA002-DIP28, dsPIC33FJ12GP202-DIP28, dsPIC33FJ12MC202-DIP28, dsPIC33FJ32GP202-DIP28, dsPIC33FJ32MC202-DIP28, PIC24HJ128GP502-DIP28, PIC24HJ128GP202-DIP28, PIC24HJ32GP302-DIP28, dsPIC33FJ128GP802-DIP28, dsPIC33FJ128GP202-DIP28, dsPIC33FJ64GP802-DIP28, dsPIC33FJ64GP202-DIP28, dsPIC33FJ32GP302-DIP28, dsPIC33FJ128MC802-DIP28, dsPIC33FJ128MC202-DIP28, dsPIC33FJ64MC802-DIP28, dsPIC33FJ64MC202-DIP28 and dsPIC33FJ32MC302-DIP28

44-pin MCU cards *MCU Card 12* support the following microcontrollers: PIC24HJ32GP204-PT, PIC24HJ16GP304-PT, PIC24FJ16GA004-PT, PIC24FJ32GA004-PT, PIC24FJ48GA004-PT, PIC24FJ64GA004-PT, dsPIC33FJ32GP204-PT, dsPIC33FJ16GP304-PT, dsPIC33FJ32MC204-PT, dsPIC33FJ16MC304-PT, PIC24HJ128GP504-PT, PIC24HJ128GP204-PT, PIC24HJ64GP504-PT, PIC24HJ64GP204-PT, PIC24HJ32GP304-PT, dsPIC33FJ128GP804-PT, dsPIC33FJ128GP204-PT, dsPIC33FJ64GP804-PT, dsPIC33FJ64GP204-PT, dsPIC33FJ32GP304-PT, dsPIC33FJ128MC804-PT, dsPIC33FJ128MC204-PT, dsPIC33FJ64MC804-PT, dsPIC33FJ64MC204-PT and dsPIC33FJ32MC304-PT

64-pin MCU cards *MCU Card 13* support the following microcontrollers: PIC24FJ64GB106-PT, PIC24FJ128GB106-PT, PIC24FJ192GB106-PT and PIC24FJ256GB106-PT

80-pin MCU cards *MCU Card 14* support the following microcontrollers: PIC24FJ64GB108-PT, PIC24FJ128GB108-PT, PIC24FJ192GB108-PT and PIC24FJ256GB108-PT

100-pin MCU cards *MCU Card 15* support the following microcontrollers: PIC24FJ64GB110-PT, PIC24FJ128GB110-PT, PIC24FJ192GB110-PT and PIC24FJ256GB110-PT

100-pin MCU cards *MCU Card 16* support the following microcontrollers: PIC24FJ64GB110-PF, PIC24FJ128GB110-PF, PIC24FJ192GB110-PF and PIC24FJ256GB110-PF

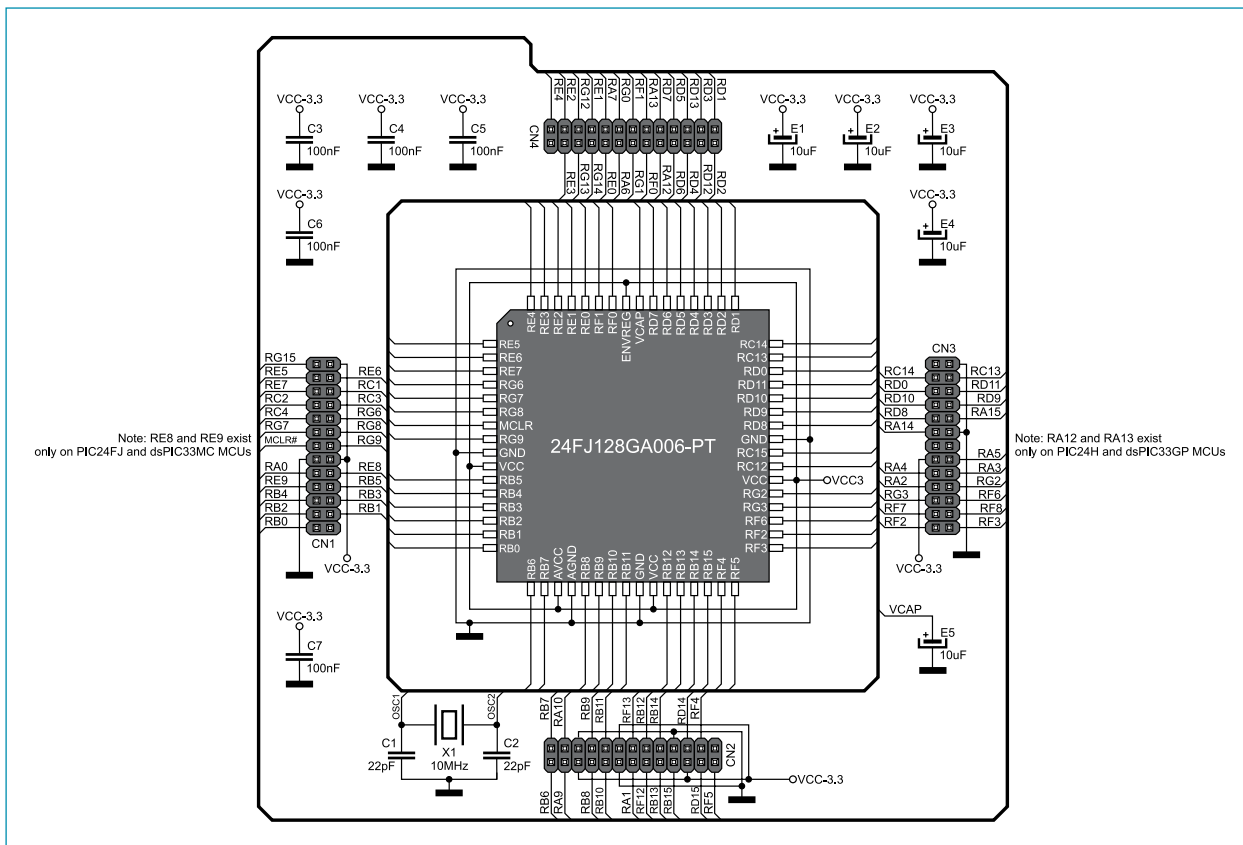

Figure 1: 64-pin MCU card *MCU Card 1* and microcontroller connection schematic

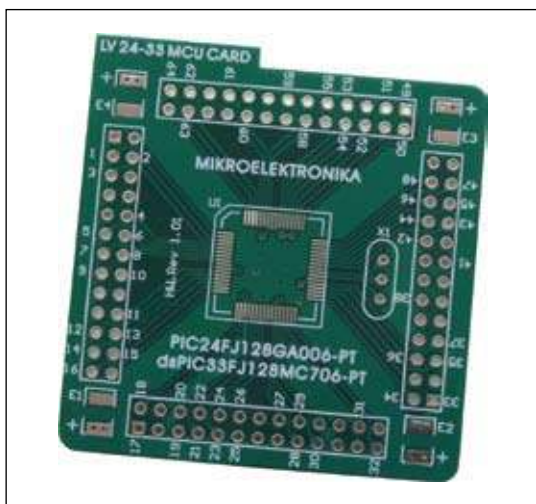

Figure 2: Empty MCU card *MCU Card 1*

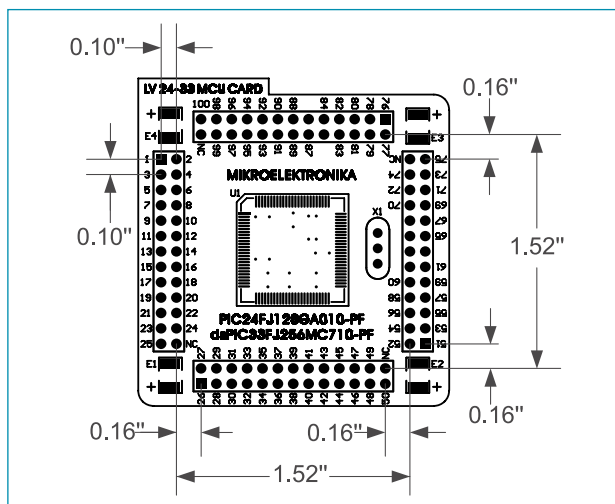

Figure 3: Dimensions of MCU card for *MCU Card 1* to *MCU Card 8*

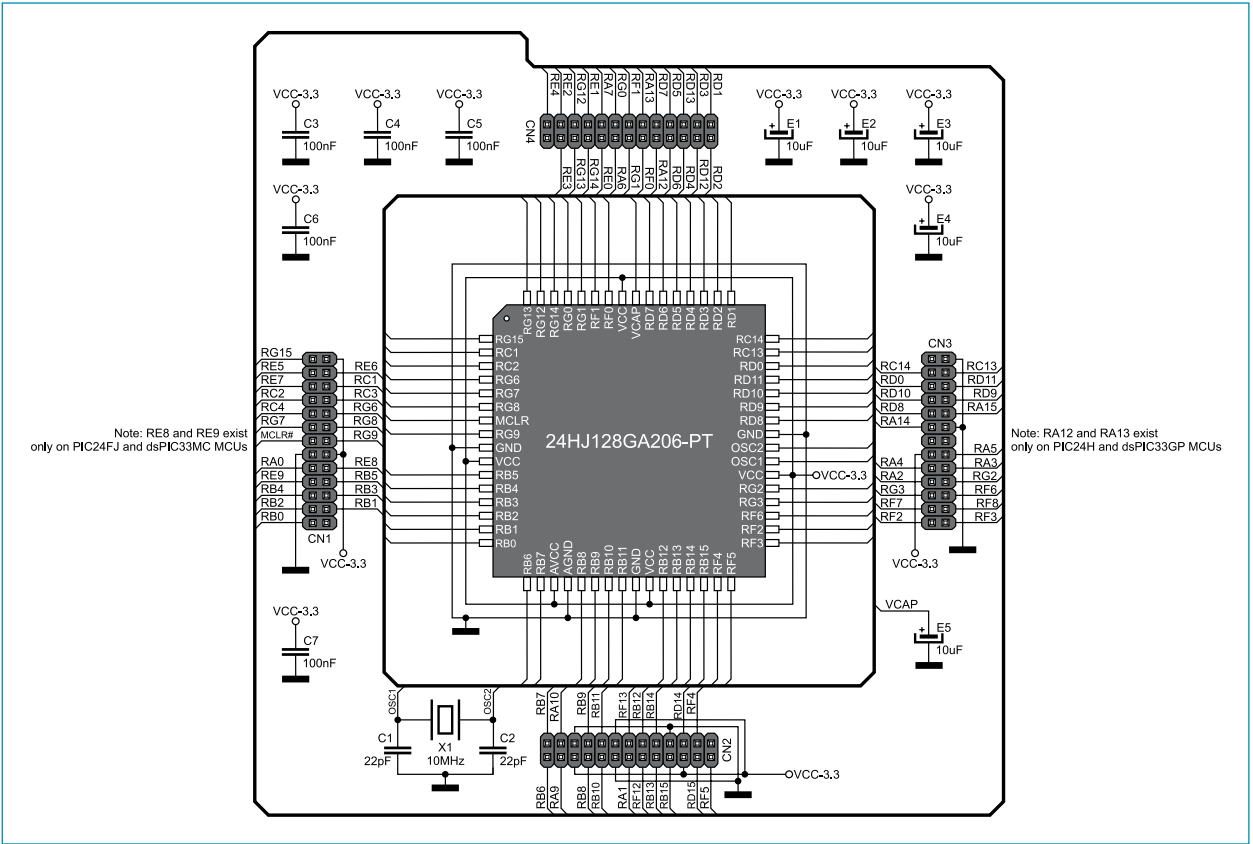

Figure 4: 64-pin MCU card MCU Card 2 and microcontroller connection schematic

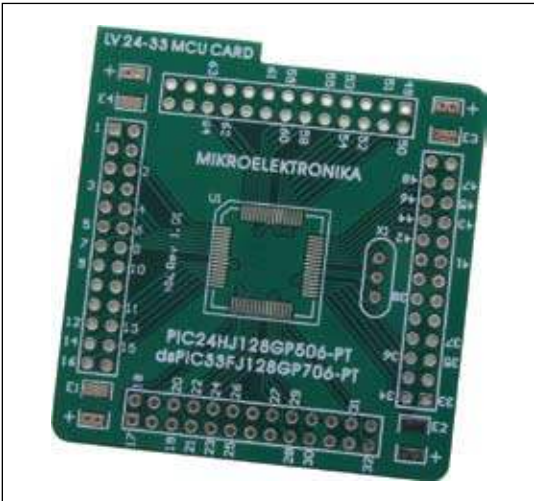

Figure 5: Empty MCU card MCU Card 2

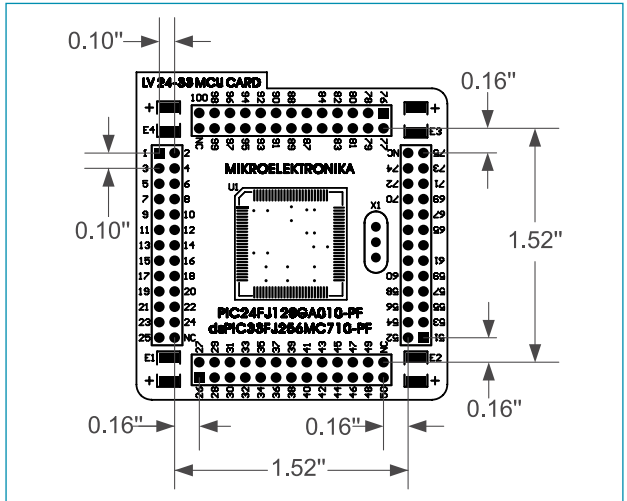

Figure 6: Dimensions of MCU card for MCU Card 1 to MCU Card 8

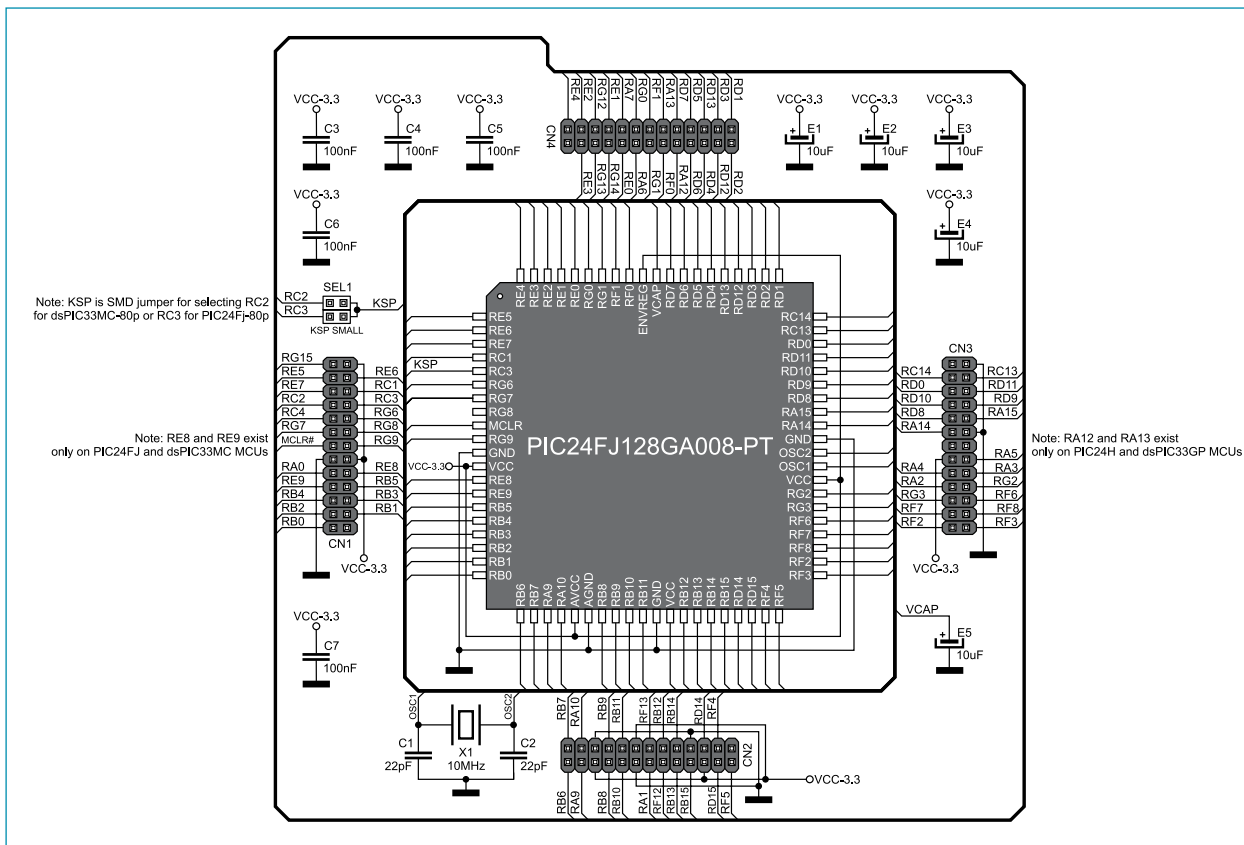

Figure 7: 80-pin MCU card MCU Card 3 and microcontroller connection schematic



Figure 8: Empty MCU card MCU Card 3

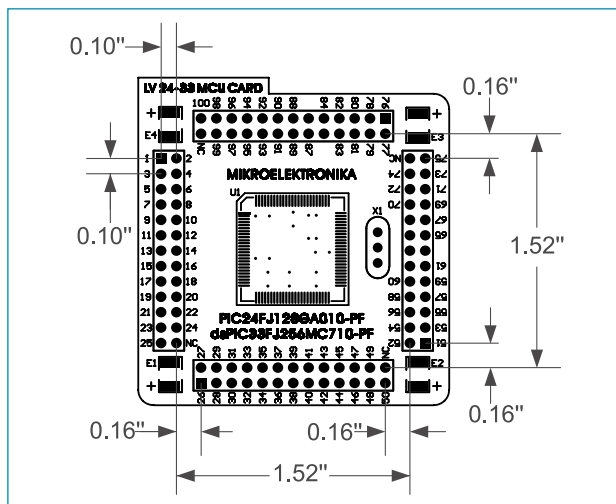

Figure 9: Dimensions of MCU card for MCU Card 1 to MCU Card 8

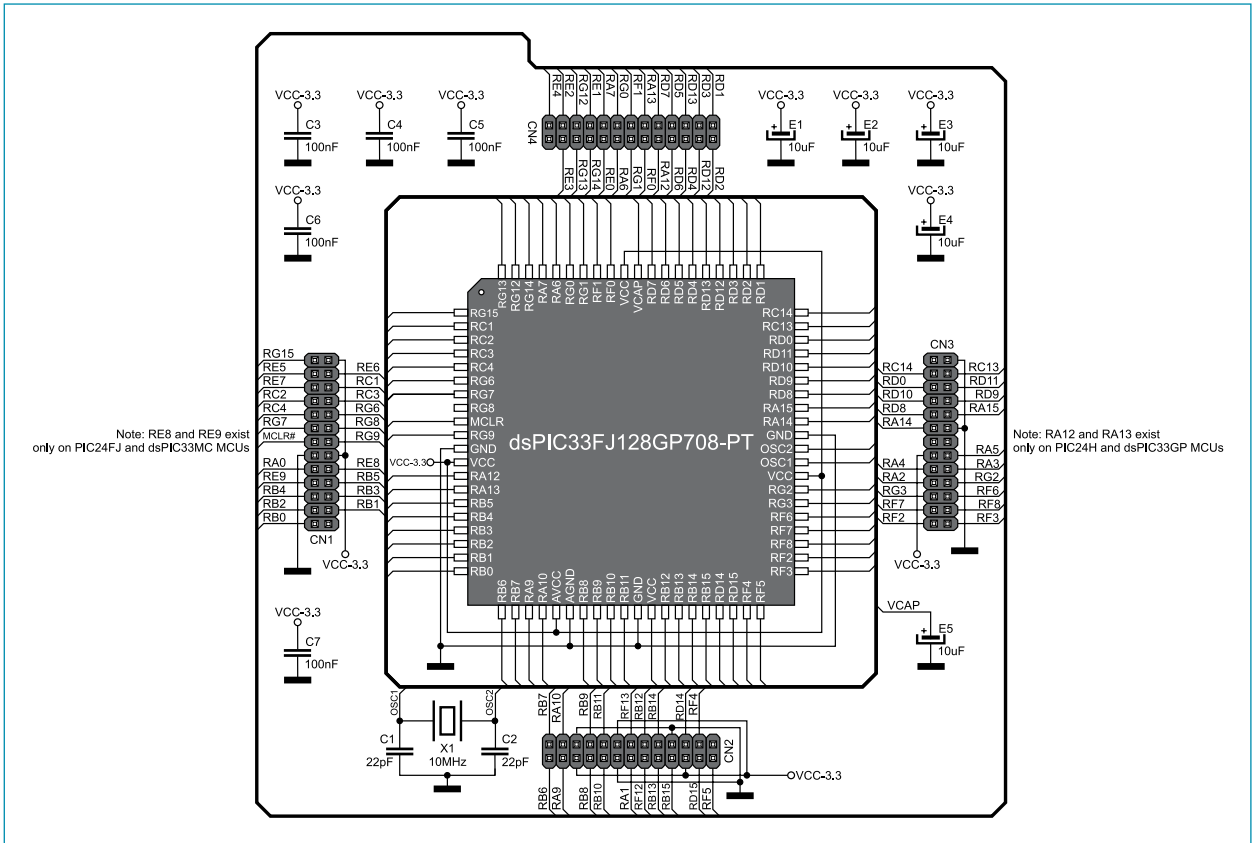

Figure 10: 80-pin MCU card *MCU Card 4* and microcontroller connection schematic

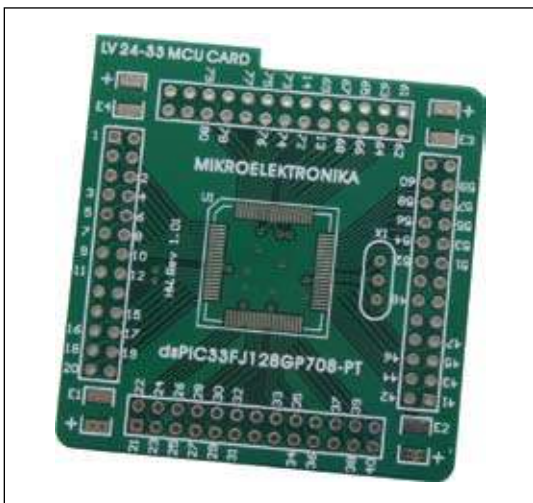

Figure 11: Empty MCU card *MCU Card 4*

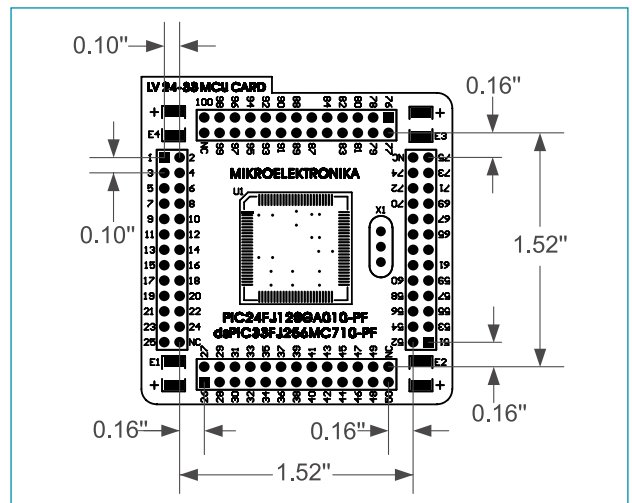

Figure 12: Dimensions of MCU card for *MCU Card 1* to *MCU Card 8*

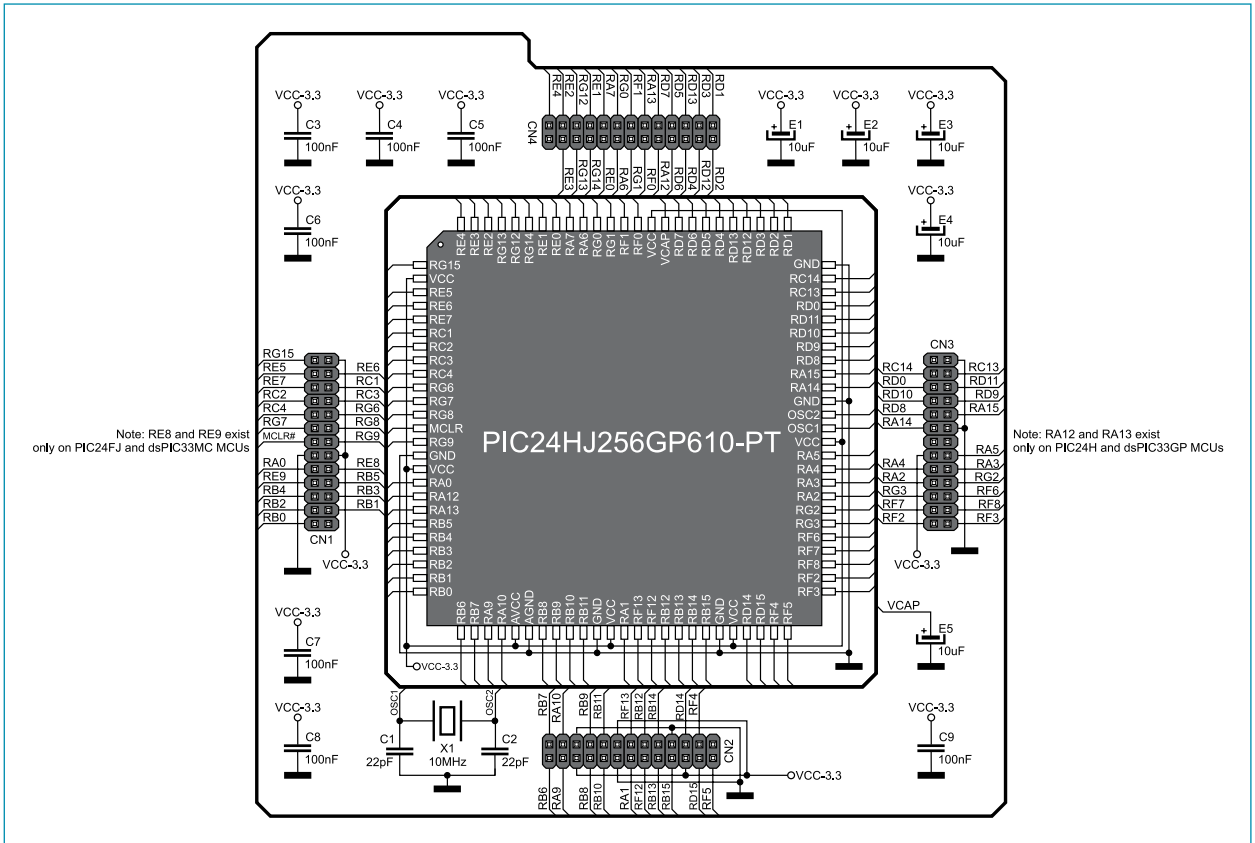

Figure 16: 100-pin MCU card *MCU Card 6* and microcontroller connection schematic



Figure 17: Empty MCU card *MCU Card 6*

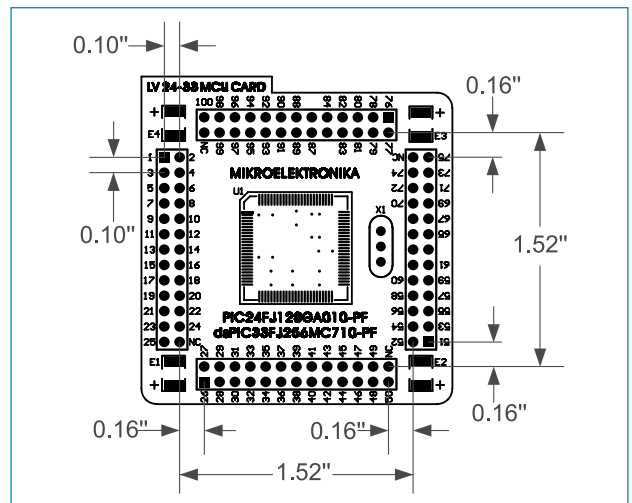

Figure 18: Dimensions of MCU card for *MCU Card 1* to *MCU Card 8*

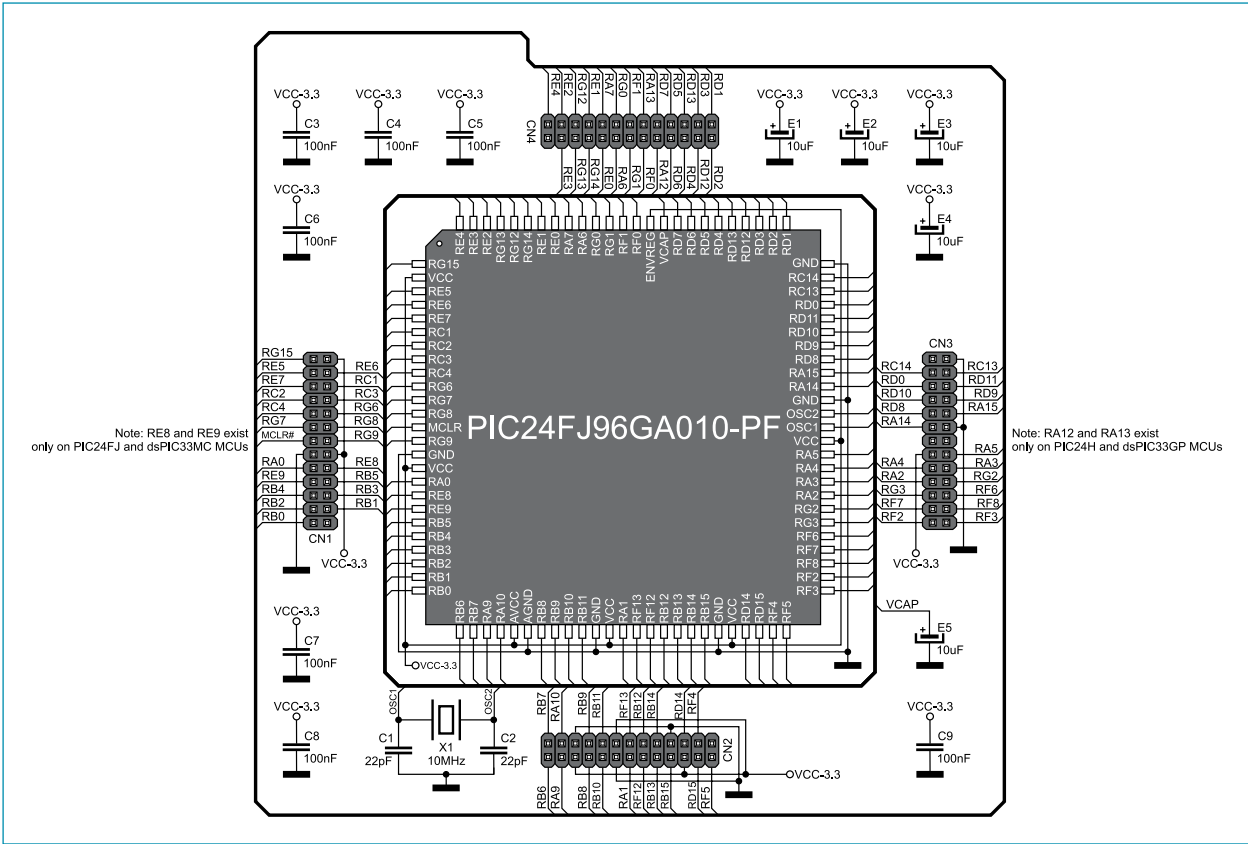

Figure 19: 100-pin MCU card MCU Card 7 and microcontroller connection schematic

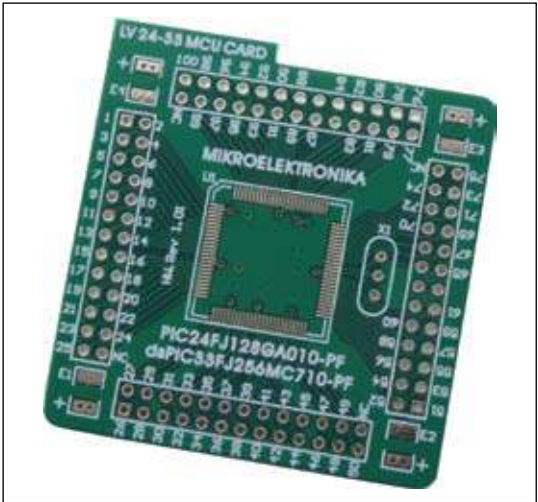

Figure 20: Empty MCU card MCU Card 7

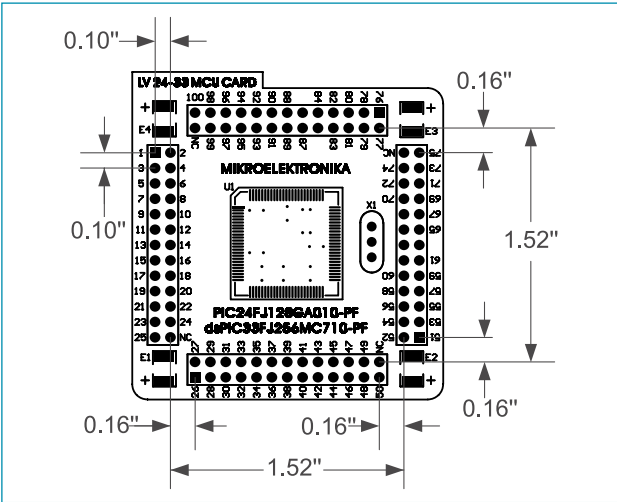

Figure 21: Dimensions of MCU card for MCU Card 1 to MCU Card 8

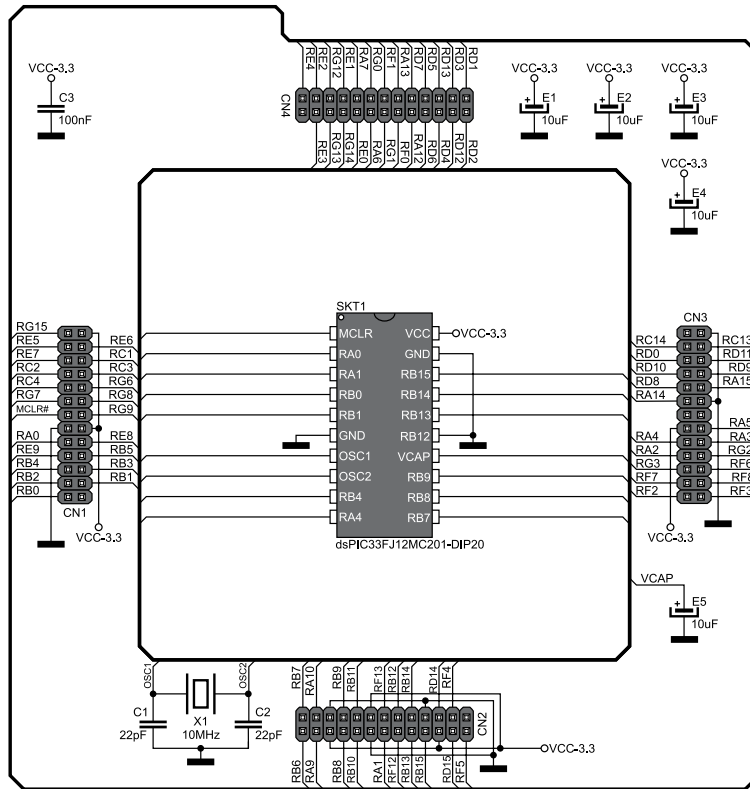

Figure 28: 20-pin MCU card *MCU Card 10* and microcontroller connection schematic

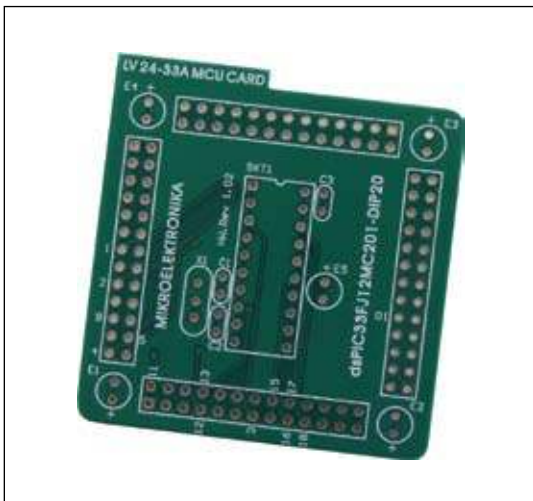

Figure 29: Empty MCU card *MCU Card 10*

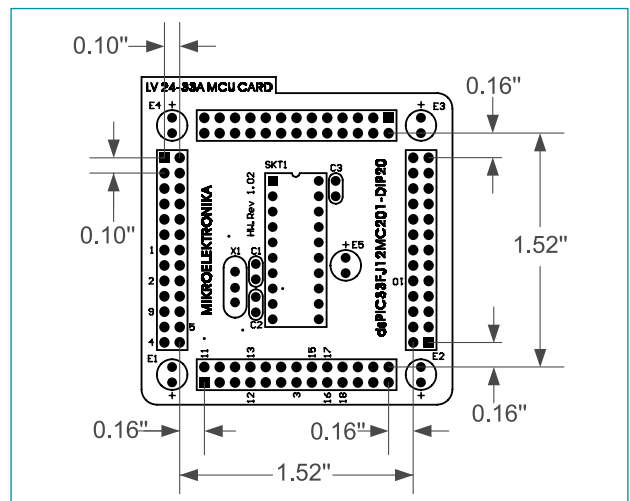

Figure 30: Dimensions of MCU card for *MCU Card 10*

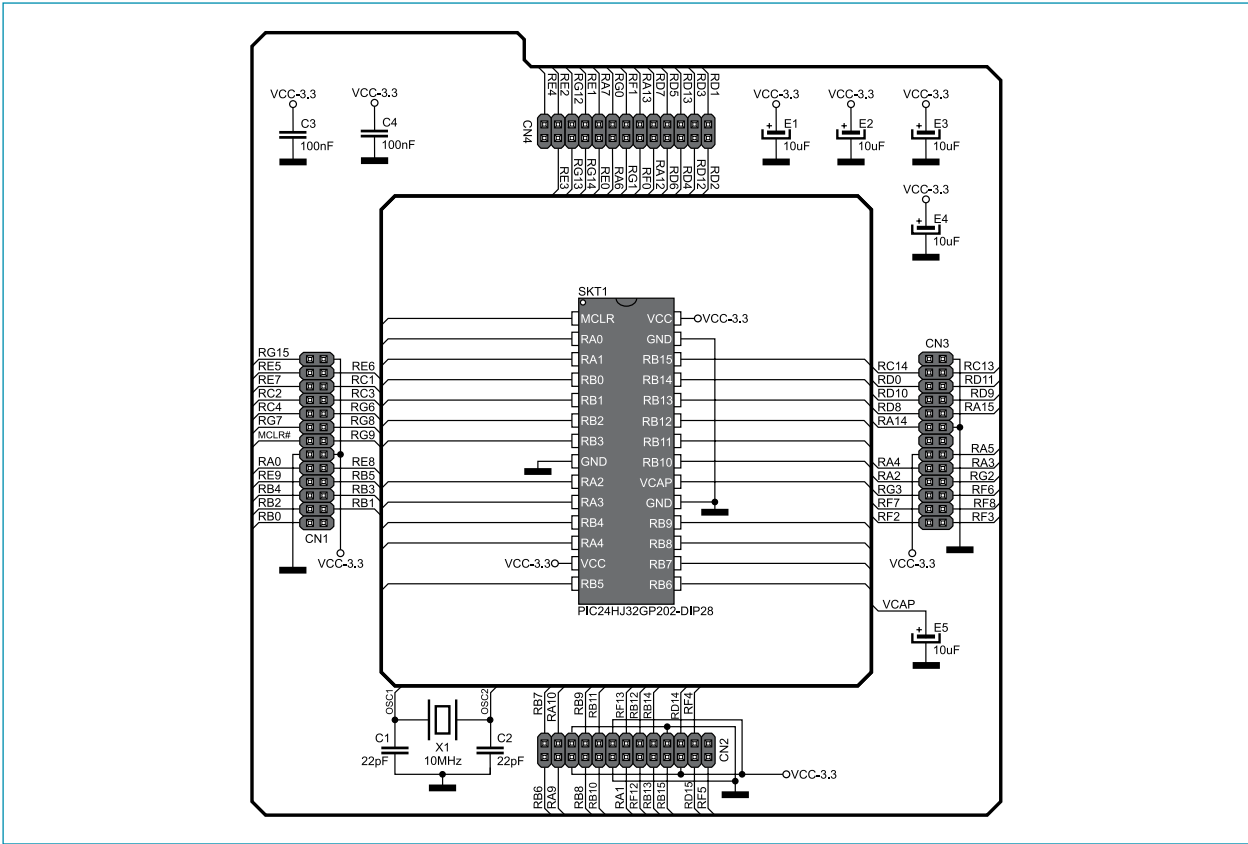

Figure 31: 28-pin MCU card MCU Card 11 and microcontroller connection schematic

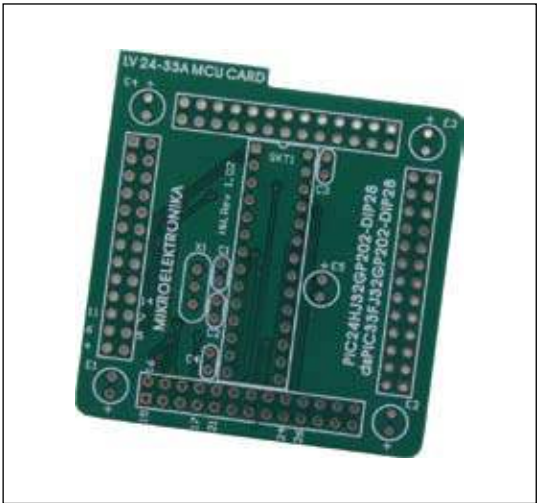

Figure 32: Empty MCU card MCU Card 11

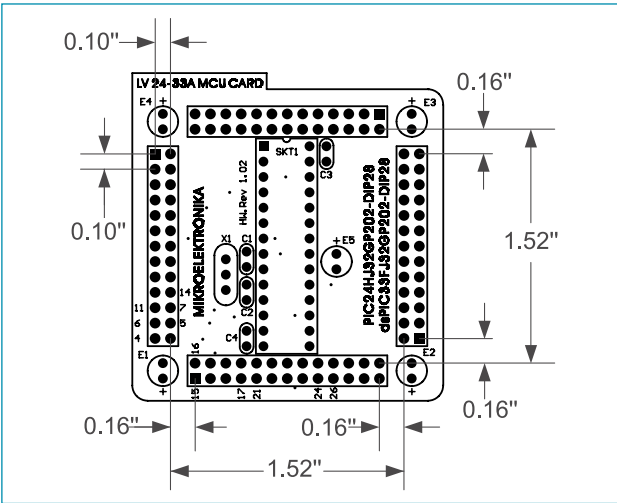

Figure 33: Dimensions of MCU card for MCU Card 11

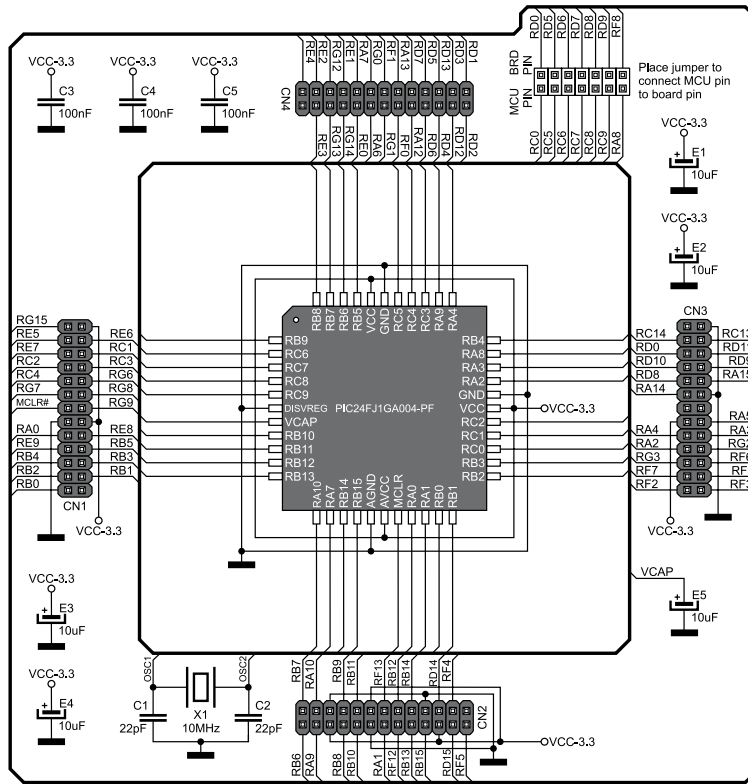

Figure 34: 44-pin MCU card *MCU Card 12* and microcontroller connection schematic



Figure 35: Empty MCU card *MCU Card 12*

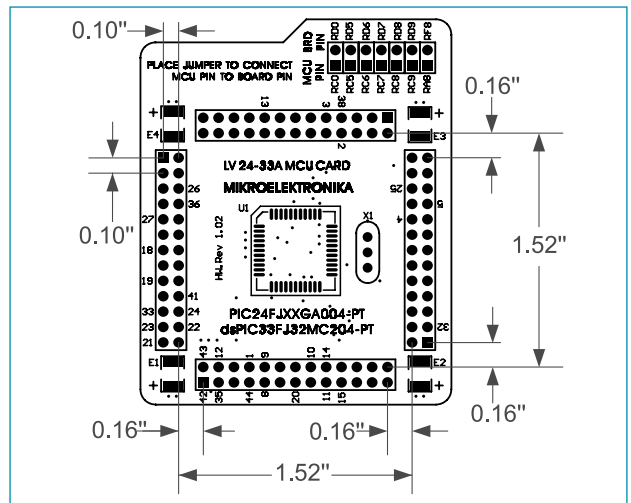

Figure 36: Dimensions of MCU card for *MCU Card 12*

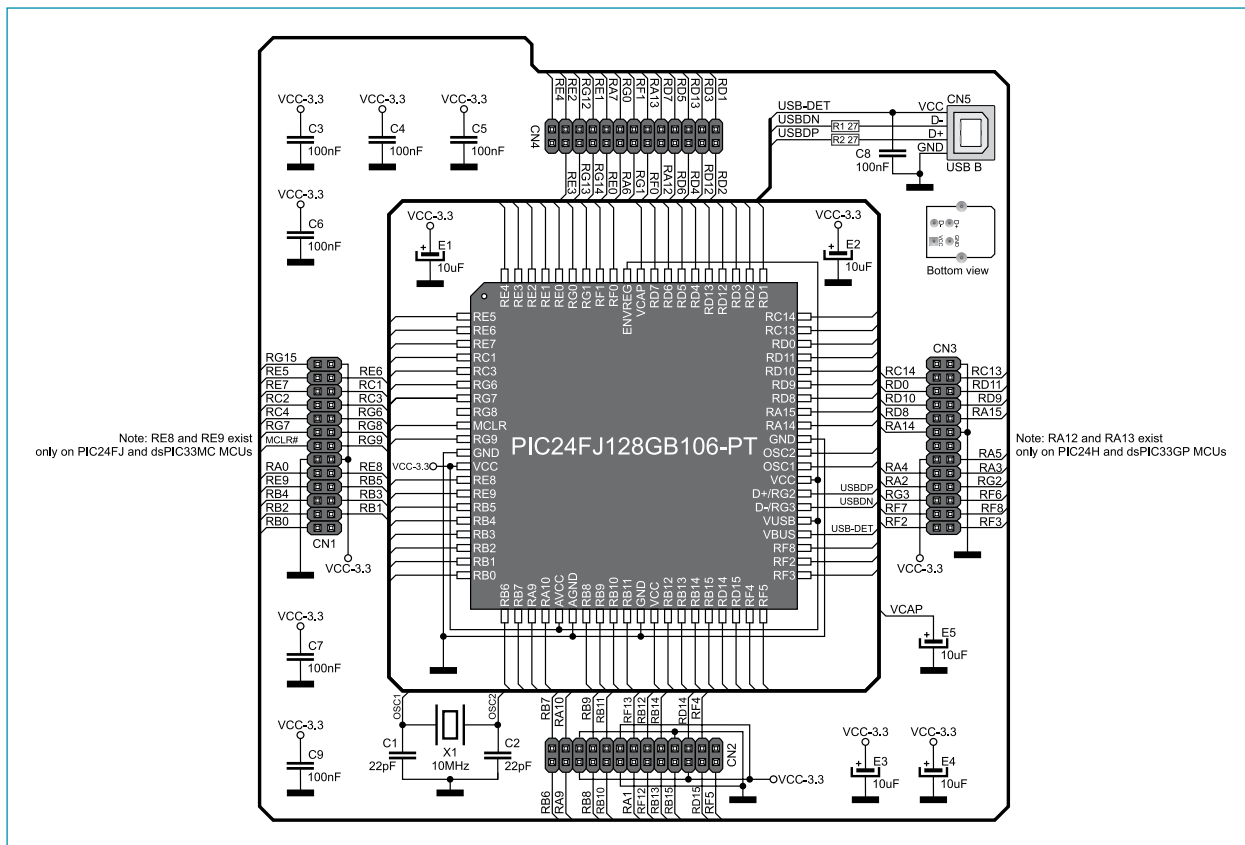

Figure 37: 80-pin MCU card MCU Card 13 and microcontroller connection schematic

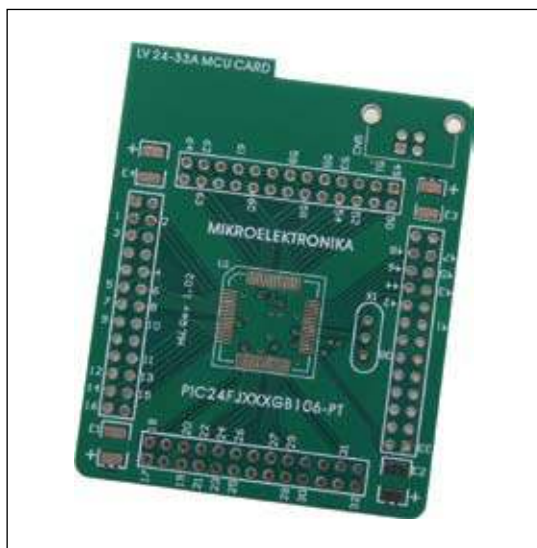

Figure 38: Empty MCU card MCU Card 13

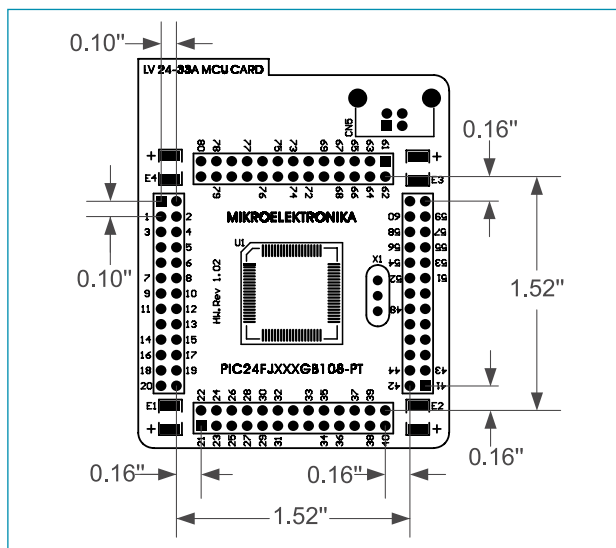

Figure 39: Dimensions of MCU card for MCU Card 13

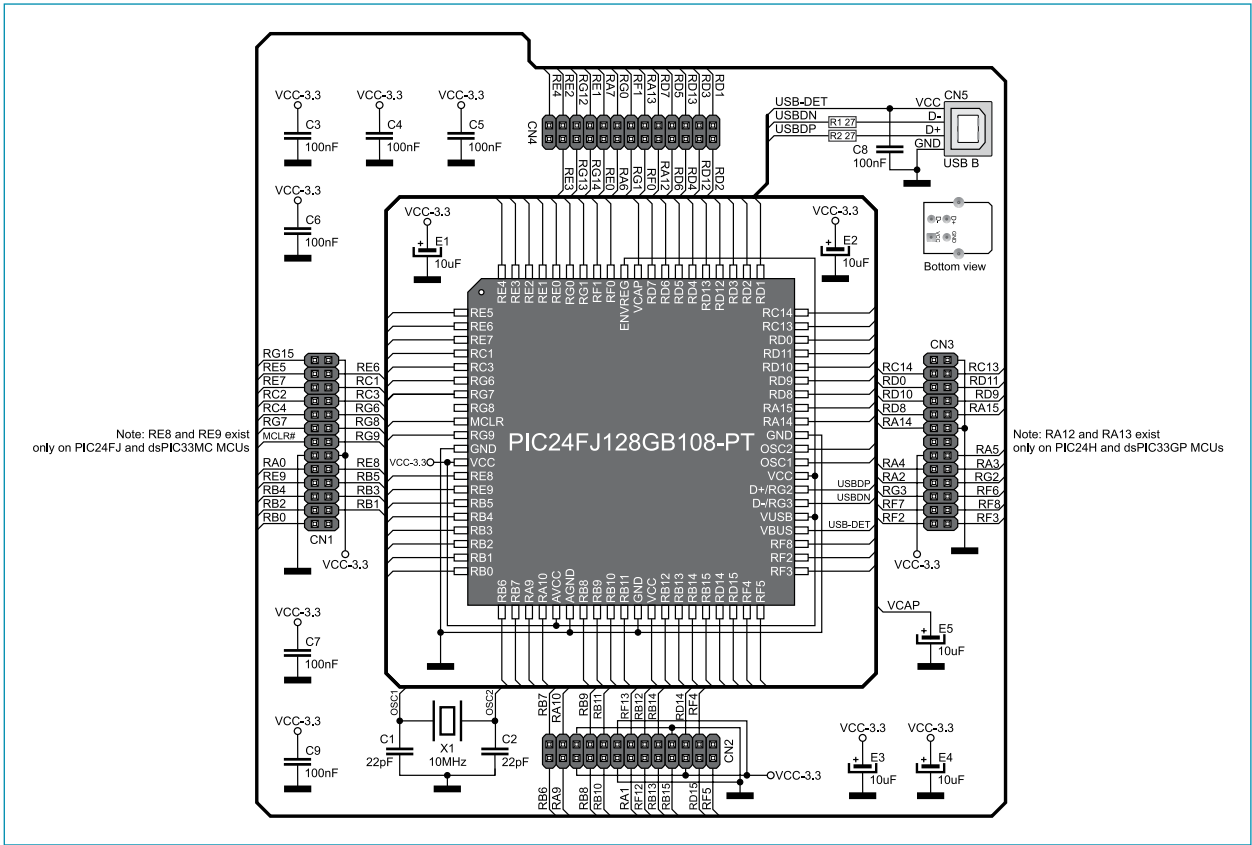

Figure 40: 80-pin MCU card MCU Card 14 and microcontroller connection schematic



Figure 41: Empty MCU card MCU Card 14

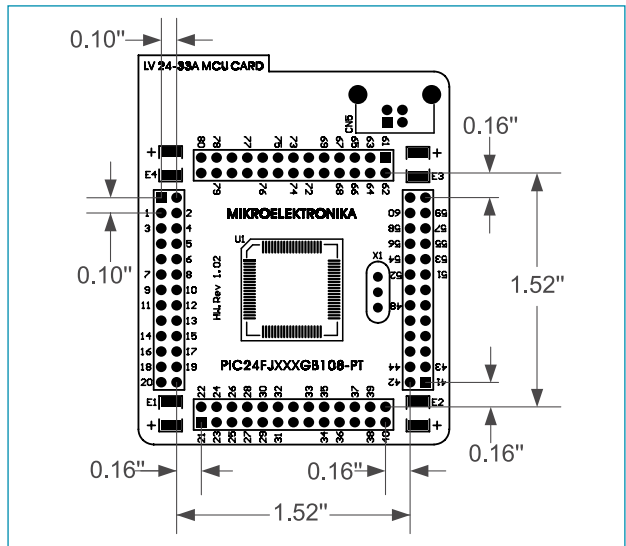

Figure 42: Dimensions of MCU card for MCU Card 14

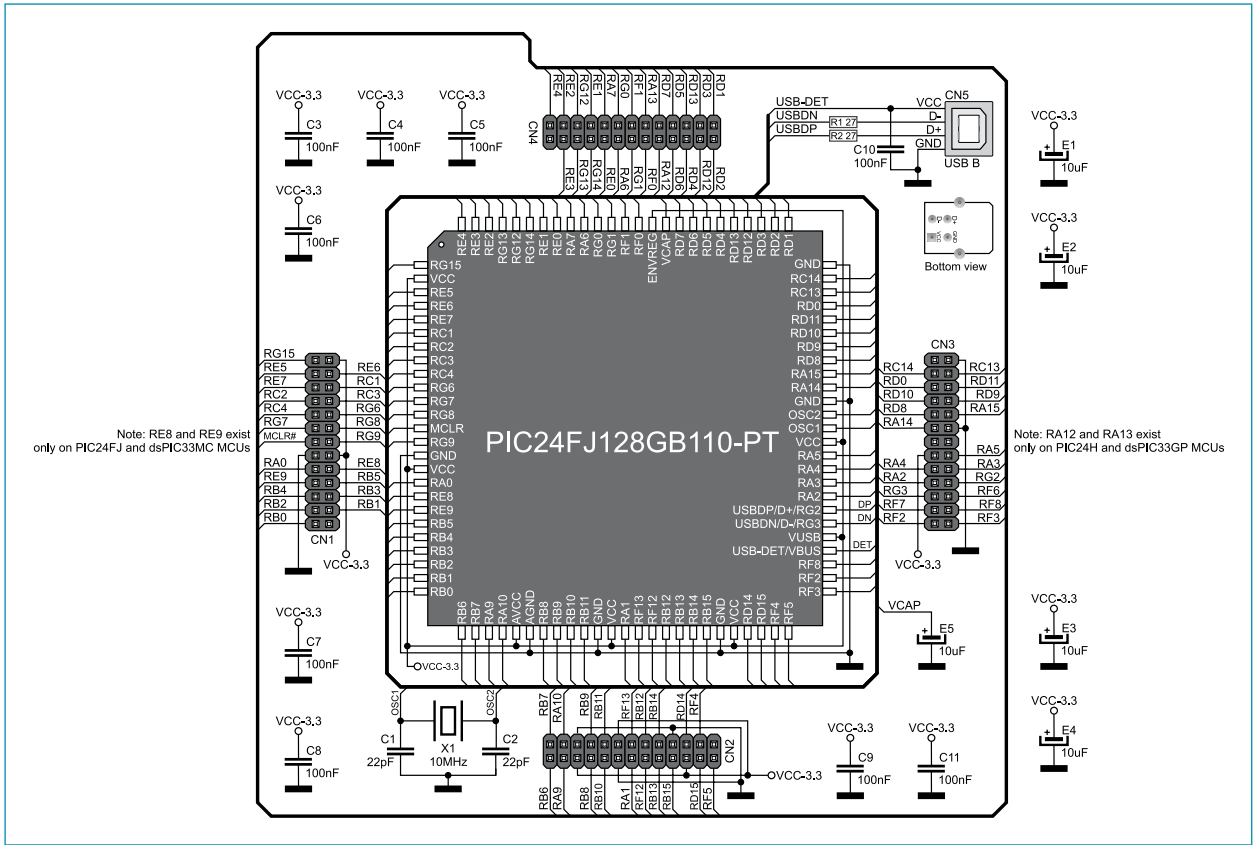

Figure 43: 100-pin MCU card MCU Card 15 and microcontroller connection schematic

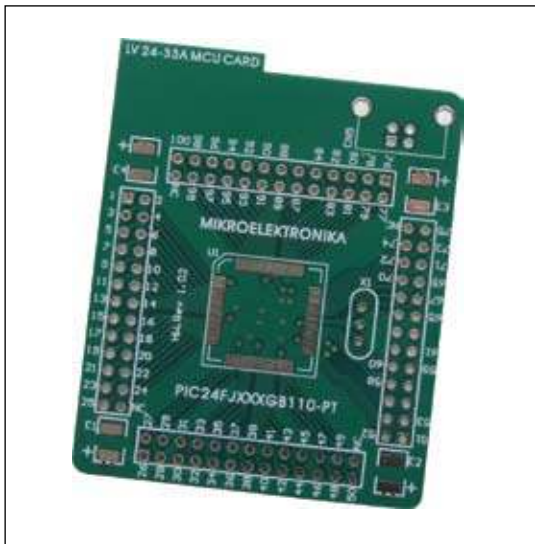

Figure 44: Empty MCU card MCU Card 15

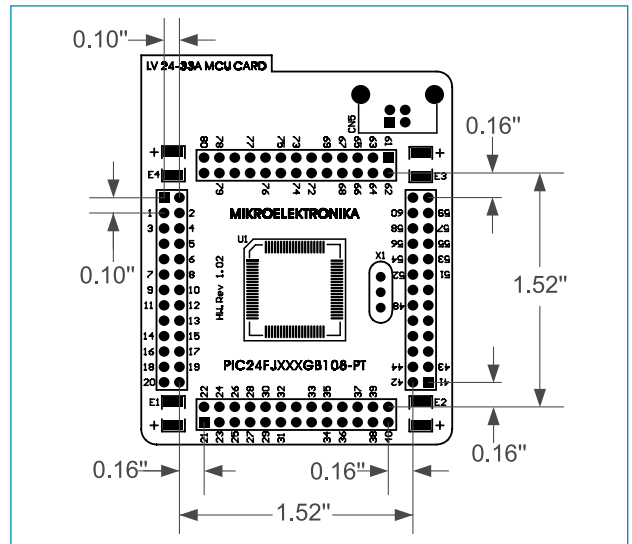

Figure 45: Dimensions of MCU card for MCU Card 15

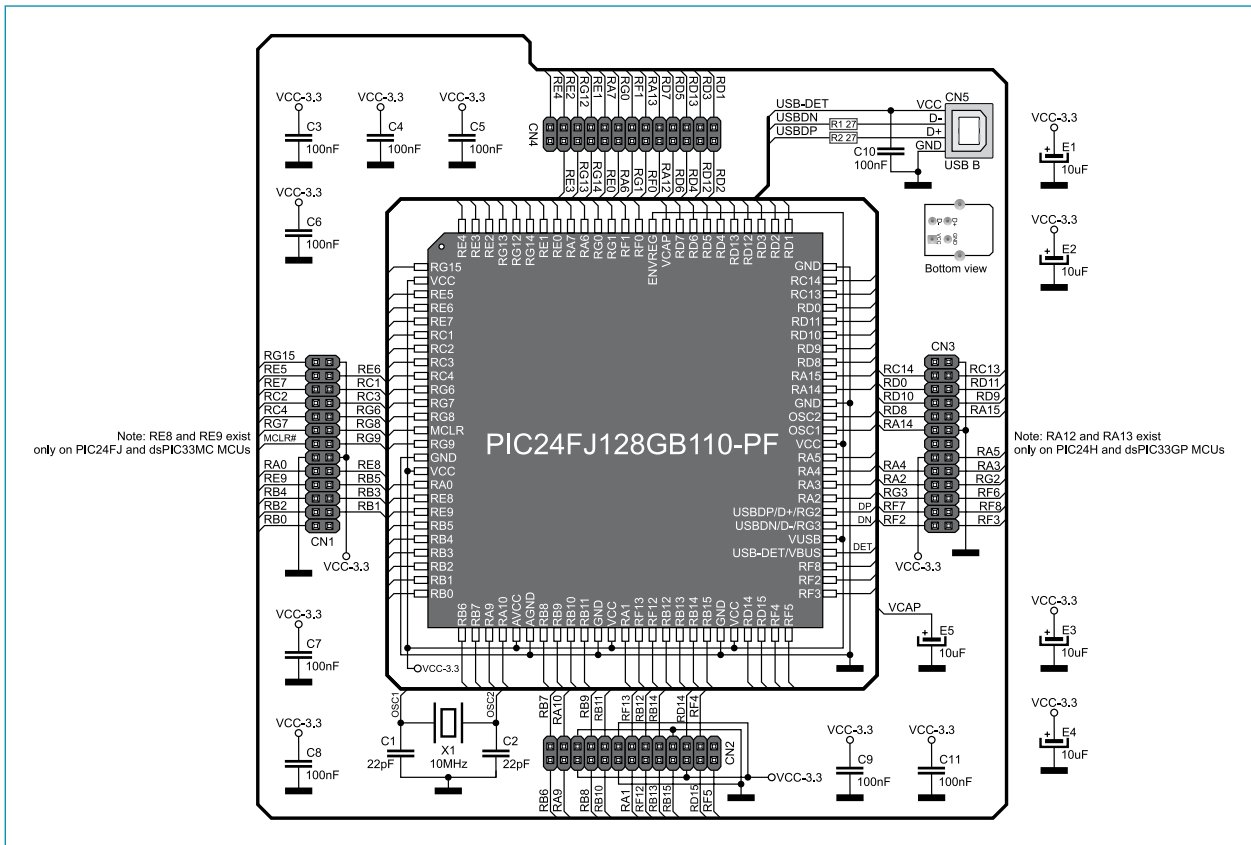

Figure 46: 100-pin MCU card *MCU Card 16* and microcontroller connection schematic



Figure 47: Empty MCU card *MCU Card 16*

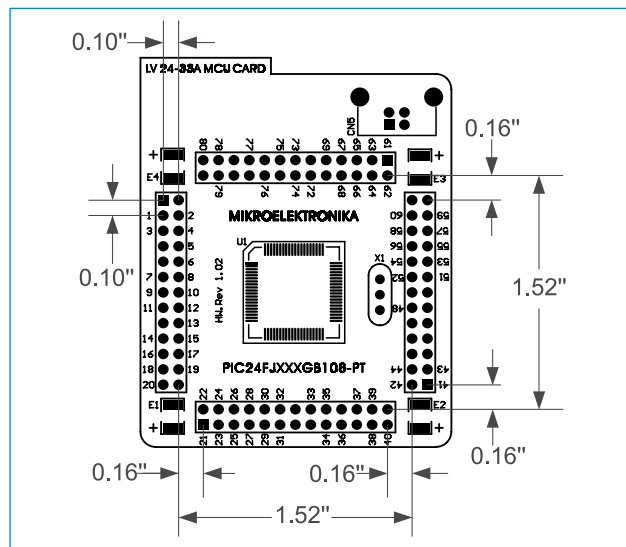

Figure 48: Dimensions of MCU card for *MCU Card 16*



MikroElektronika

SOFTWARE AND HARDWARE SOLUTIONS FOR EMBEDDED WORLD ...making it simple

If you want to learn more about our products, please visit our website at www.mikroe.com

If you are experiencing some problems with any of our products or just need additional information, please place your ticket at www.mikroe.com/en/support

If you have any questions, comments or business proposals, do not hesitate to contact us at office@mikroe.com