

Digital Pressure Gauge

DPG Battery Powered



Features:

- Gauge or Absolute pressure
- ABS Plastic Housing
- Alarm relay, max/min information
- 5000 point data logger with USB interface
- Built-in temperature compensated Pressure Sensor

Description:

The DPGB series battery powered gauge can be supplied in gauge or absolute pressure formats and displays the sensor pressure in bar, PSI or the user's engineering unit on a 6-digit LCD display. The instrument offers an advanced display mode allowing the user to also display one or two (1 to 32) character messages.

Additional to the messages, the user may select an alert-event to occur when the pressure is within a band. A change-over relay can be used together with the messaging and alerts to provide switching at user-set points. In addition to this, on-board datalogging is also available to record process details at up to 5000 points.

Specification:

- Range: 0 - 600 Bar
- Overpressure: 1.5x full scale
- Measurement type: Gauge / Absolute
- Accuracy: $\pm 0.5\%$ F.S. BFSL@25C
- Temperature compensation: Automatic
- Total error: 1%
- Working Temperature: -10C - 80C
- Stability: $\pm 0.2\%$ F.S. /year
- Process fitting: G1/4" (other types available on request)
- User changeable pressure units via software
- Stainless Steel Pressure Sensor Housing, ABS enclosure and Clear Polycarbonate display cover.

Applications:

- For use with gas or liquid.
- General Industrial including, Plant, Machine, Heating and Water applications
- Use the relay to control alarms and other process actions.

Digital Pressure Gauge

DPG Battery Powered



Features

INPUT PARAMETERS

Range	600 Bar
Over pressure	1.5 times FS
Accuracy	+/- 0.5% within compensated range
Operating temperature	-10 C - 80C
Storage temperature	-40C - 125C
Long term stability	+/- 0.2% FS/ YR

DATA LOGGING FUNCTION

The DPGB series also provides a powerful data logging function. The log points can be set up to 5000 points; each point is time and date-stamped together with process value, and relay state information. The log rate is selectable in steps. The start of log can be delayed if required. Either fixed or rolling logs may be performed. The USB configuration reads the log and allows the user to save to a text file for export to other programs.

REAL-TIME CLOCK

Date and time can also be displayed with the input pressure. The real-time clock is used to record the data logged points.

RELAY

The instrument is equipped with single volt-free changeover-type relay. The user may select one of several actions, including deviation operation, with fully adjustable set point and dead-band. An option is provided to trigger an alert-event when a relay contact is on.

CALIBRATION/USER-LINEARISATION

5-point calibration can be applied using the USBSpeedLink software. As well as straight line interpolation, up to 22 points (x,y) of user-linearisation are available for creating custom curves and corrections.

General Note

TT Electronics reserves the right to make changes in product specification without notice or liability. All information is subject to TT Electronics' own data and is considered accurate at time of going to print.

TT Electronics | Roxspur Measurement & Control Ltd 2 Downgate Drive, Sheffield, S4 8BT, England | Ph: +44(0)114 244 2521
www.roxspur.com | sales@roxspur.com

Specifications

Body type B

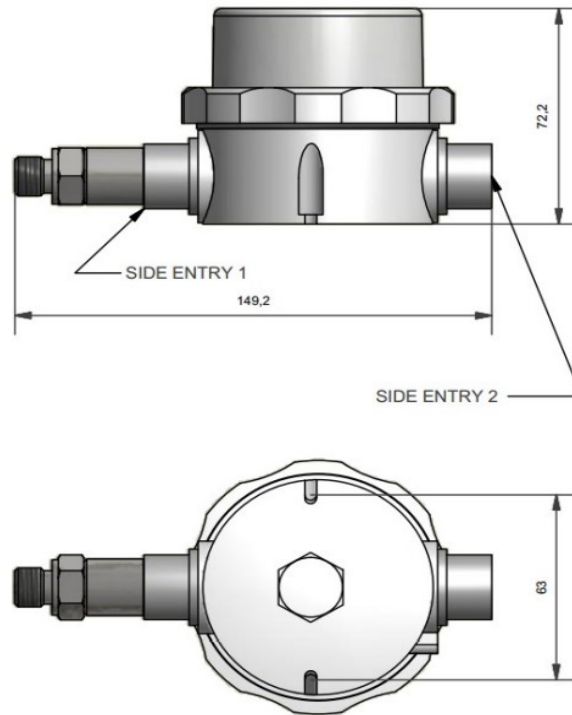

DISPLAY

Type/options/function

Display height
Display information options

High intensity LED

Description

7.9 mm non-backlit
Pressure value, Process value, °C or °F plus “Loss of power”, “USB”, icons,
8 segment log volume/signal indicators
Warning options

MECHANICAL

Enclosure (case)

Display cover

Case entry

Front bezel diameter

Weight (approximate)

Material in contact with media O-ring

ABS, grey base, blue clamp ring

Polycarbonate, clear

1 x M20 female thread, blanking plug supplied

65 mm

240 g

Stainless steel 316L

Viton

General Note

TT Electronics reserves the right to make changes in product specification without notice or liability. All information is subject to TT Electronics' own data and is considered accurate at time of going to print.

Digital Pressure Gauge

DPG Battery Powered



Specifications

CONNECTIONS

Sensor to process	¼ inch BSP male
Output	Two-part screw connectors
USB connection	USB mini B port

ENVIRONMENTAL

Function	Description
Ambient housing temperature	Operating/storage (-30 - 70) °C
Ambient sensor temperature	Operating (-10 - 80) °C
Ambient humidity	Operating/storage (10 - 90) %RH non-condensing
Protection	IP67, cable entry must be sealed to IP67
USB configuration ambient	(10 - 30) °C

RELAY

Type/options/function	Description
Independent relay	Single pole change-over (common, N/o, N/c)
Rating	48 VDC maximum @ 1 A (5 mA minimum) 28 VAC RMS maximum @ 1 A

APPROVALS

EMC	BS EN 61326
Ingress protection	BS EN 60529
RoHS	Directive 2011/65/EU

Digital Pressure Gauge

DPG Battery Powered



Specifications

USB CONFIGURATION USER INTERFACE

Type/options/function	Description	Notes
Configuration hardware	USB Mini B port	Cable not included
Configuration software	USBSpeedLink	Contact Us
Operating system	Microsoft Windows	Win 7 or later
Sensor configuration	User calibration	Up to 5 points Applied by button action
Display configuration	Display mode	Basic with advanced options
	Pressure units	Bar, PS I, mBar, Pa, KPa, MPa Kgf/m ² , Kgf/cm ² , Kgf/mm ² Atm, custom units (any)
	Custom units	With 22-point linearization
Pre-set sensor to setpoint LED alert (advanced mode)	Locks input value to setpoint Eight user adjustable pressure	For diagnostics Alert LED flash
Warning symbol	Out of range Low battery level	Warning symbol will flash on LCD display
Basic display mode	Update rate Display variable options Temperature units Alert LED	
Advanced display mode *1	Display variable (see basic mode) with messaging options	
Battery monitor	Alert LED plus message	Relay option link in software
Logger	Set device passkey number Clear, start new log	Device passkey is used to protect the NFC interface.
Other device options	Synchronise clock Write tag, contact ad- dress Read, reset maximum and mini- mum input values Latitude longitude settings	
Relay control	Name(s) Action Setpoint Dead band Latch	10 characters High, low, band, low battery, on, off In engineering units In engineering units On, off
Live data	Read sensor pressure Read displayed value Read sensor temperature Relay 1 state. Relay 2 state Time and date	bar Selected engineering unit °C

*1 Only use advanced display above -5°C ambient temperature, below use basic display

General Note
TT Electronics reserves the right to make changes in product specification without notice or liability. All information is subject to TT Electronics' own data and is considered accurate at time of going to print.

TT Electronics | Roxspur Measurement & Control Ltd 2 Downgate
Drive, Sheffield, S4 8BT, England | Ph: +44(0)114 244 2521
www.roxspur.com | sales@roxspur.com

Digital Pressure Gauge

DPG Battery Powered



Specifications

USB LOGGER USER INTERFACE

Type/options/function	Description	Notes
Logger hardware	USB Mini B port	Cable not included
Logger software	USBLogLink	Contact us
Operating system	Microsoft Windows	Win 7 or later
Logger	Start/set log parameters Read log parameters Stop, start new log Synchronise device clock Reset maximum and minimum Synchronise, read clock	Interval, rate, (delay) start, number of points, rolling or fixed log
	View log data, graph log data	Save data to CSV file

General Note

TT Electronics reserves the right to make changes in product specification without notice or liability. All information is subject to TT Electronics' own data and is considered accurate at time of going to print.

TT Electronics | Roxspur Measurement & Control Ltd 2 Downgate Drive, Sheffield, S4 8BT, England | Ph: +44(0)114 244 2521
www.roxspur.com | sales@roxspur.com

Digital Pressure Gauge

DPG Battery Powered



ORDER CODE

Series	Case material (leave blank for ABS)	Pressure range (upto 50 Bar)
DPGL (loop powered)	/SS 316 option	-XXX (ie 010, 10 Bar)
DPGB (battery powered)	/SS 316 option	-XXX (i.e. 010, 10 Bar)

Example: Loop powered, ABS body, 30 Bar Sensor
DPGL-030